

# Building Information Modelling (BIM) Training

<https://ibse.hk/BIM-Training/>



## 4.2 Revit MEP



*Ir Dr. Sam C. M. Hui*  
Department of Mechanical Engineering  
The University of Hong Kong  
E-mail: [cmhui@hku.hk](mailto:cmhui@hku.hk)

Apr 2026

# Contents



- Introduction
- Revit MEP tips
- Creating logical systems
- Mechanical systems & ductwork
- Mechanical piping
- Electrical systems
- Plumbing systems
- Fire sprinkler systems

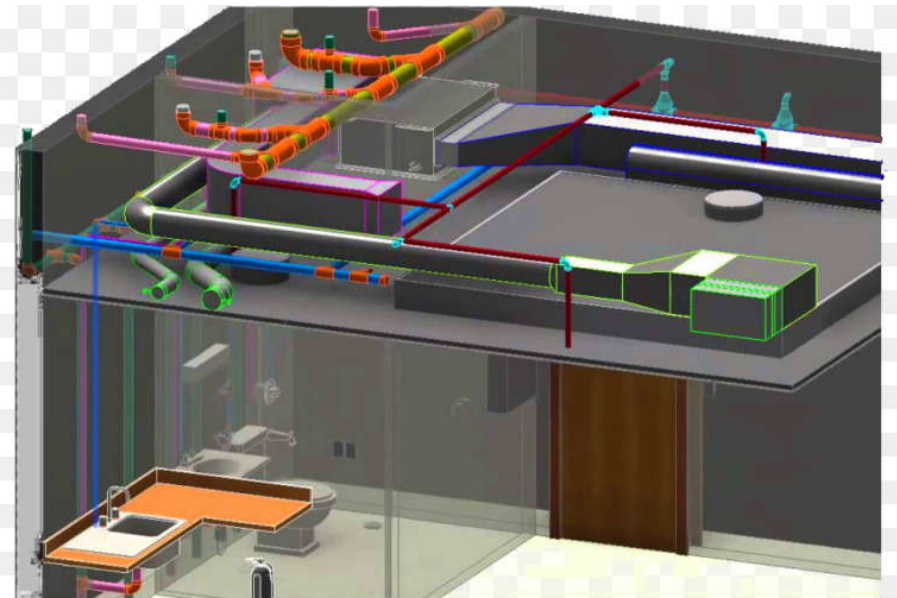

# Introduction



- Autodesk Revit & related software\*



- **Architecture, Structure, MEP**: design authoring



- **BIM 360**: collaboration

- **Fabrication CADmep**: MEP fabrication



- **Insight**: energy & building performance analysis

- **Navisworks**: project review on integrated models

- **ReCap Pro**: reality capture and 3D scanning



- **Revit Live**: immersive visualization

# Introduction



- **Revit MEP** (MEP domain)



- Help drive accurate design, analysis, and documentation of efficient building (services) systems from concept through construction
- Typical applications:
  - Building systems modelling and layout
    - Duct and pipe system modelling
    - Duct and pipe sizing/pressure calculations
    - HVAC and electrical system design
    - Conduit and cable tray modelling
  - Sustainable design with building performance analysis

# Introduction

- General Revit techniques:\*
- User interface
- Revit elements & families
- Working with views (plan, elevation, section, 3D)
- Control object visibility/graphics
- Setting up a project:
  - View templates, discipline settings, importing AutoCAD DWG, linking a Revit model, coordinating linked projects, adding & modifying levels & grids

# Revit Working Environment

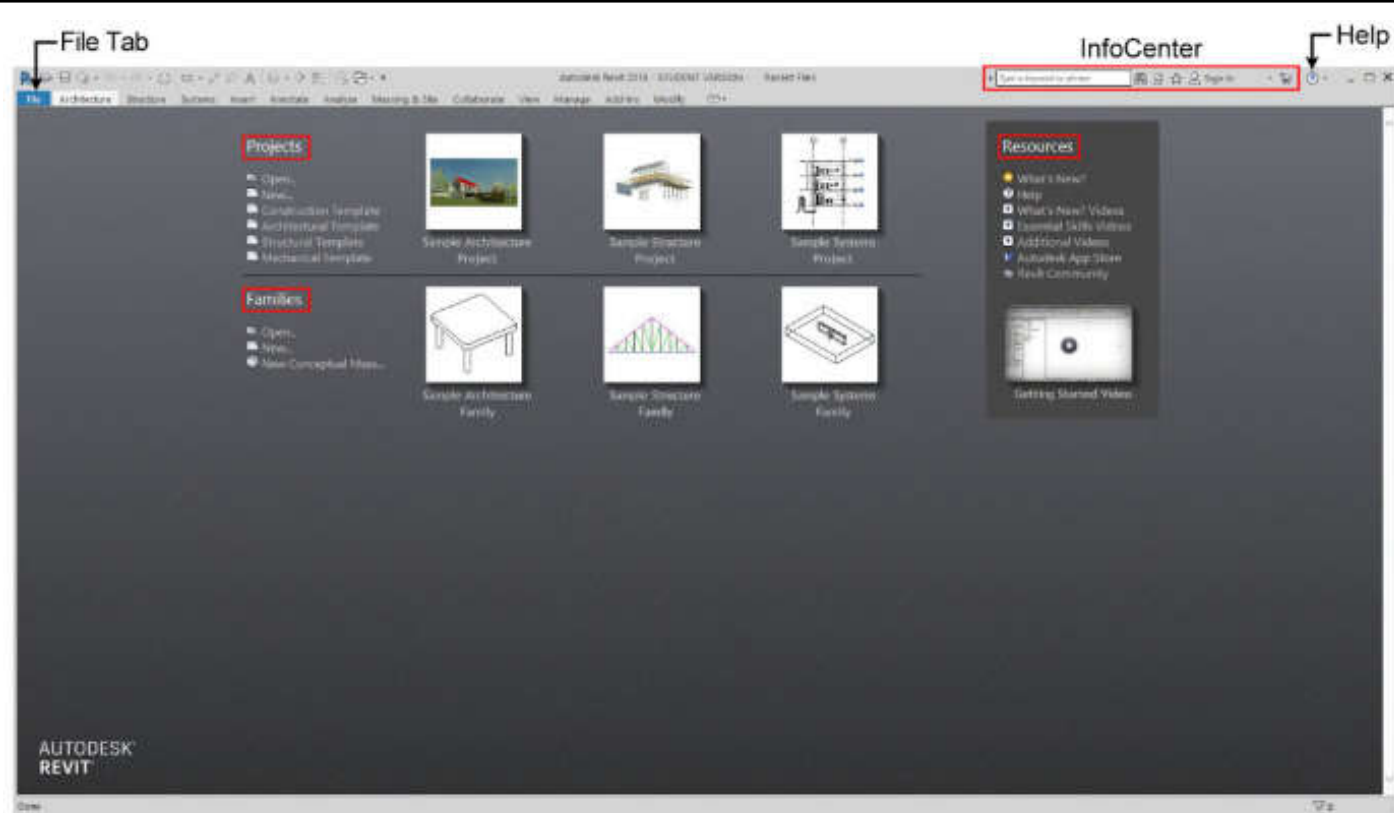

## Projects

**Open:** Open a Revit related file. (or click a right icon to open a recent project file)

**New:** Use a Revit template file to start a new project.

**Construction Template:** Use default construction template to start a new project.

**Architectural Template:** Use default architectural template to start a new project.

**Structure Template:** Use default structure template to start a new project.

**Mechanical Template:** Use default mechanical template to start a new project.

## Families

**Open:** Open a Revit family file. (or click a right icon to open a recent family file)

**New:** Use a family template to start a new family.

**New Conceptual Mass:** Use default mass family template to create a conceptual massing model.

# Project Editing Screen

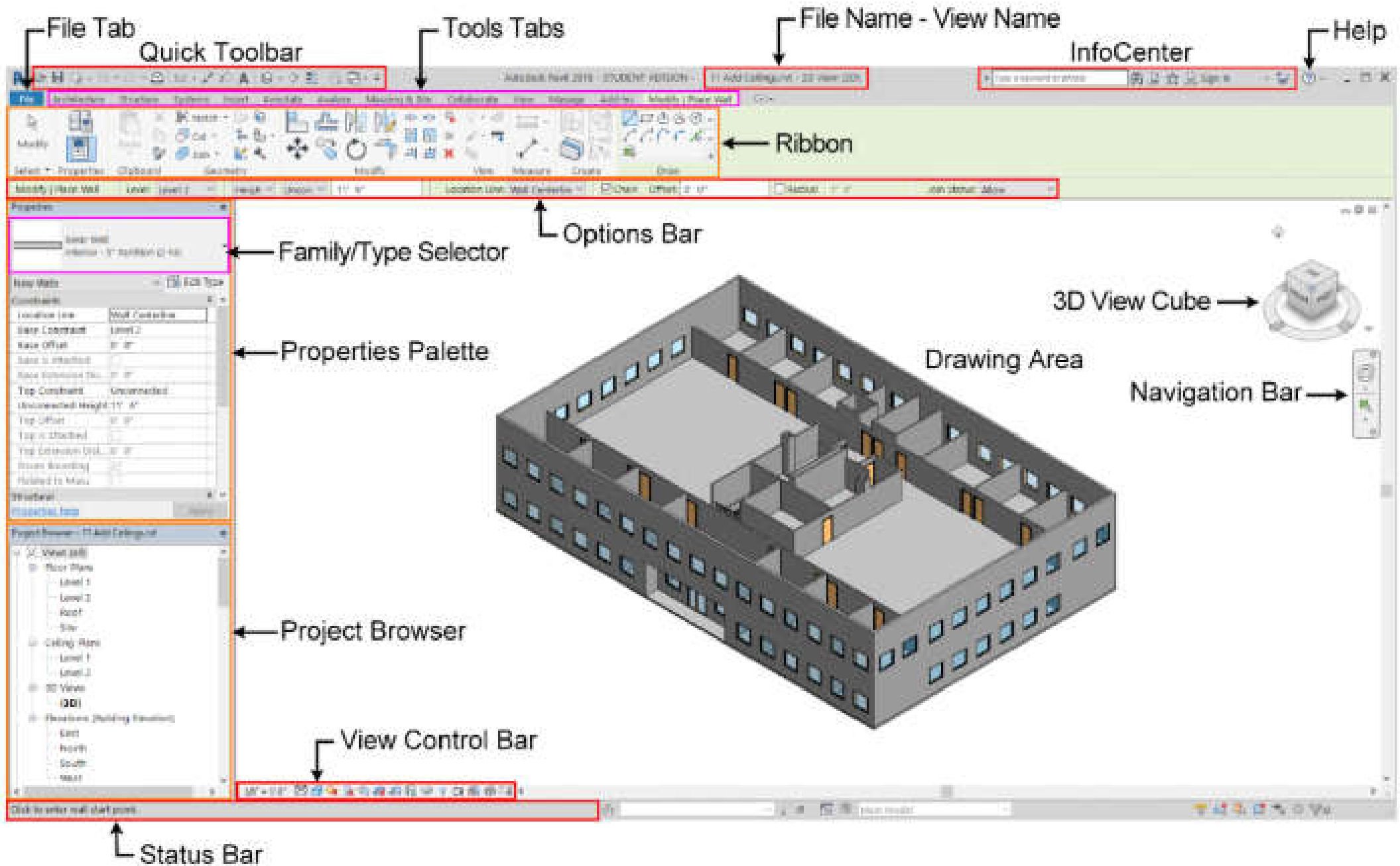

# Introduction

- Architectural modelling:
  - Floor slab, setup levels
  - Walls, partitions, doors, windows, stairs
  - Ceiling, roof & room information
- MEP systems & components:
  - Mechanical (HVAC), hydronic piping, electrical, plumbing, fire protection

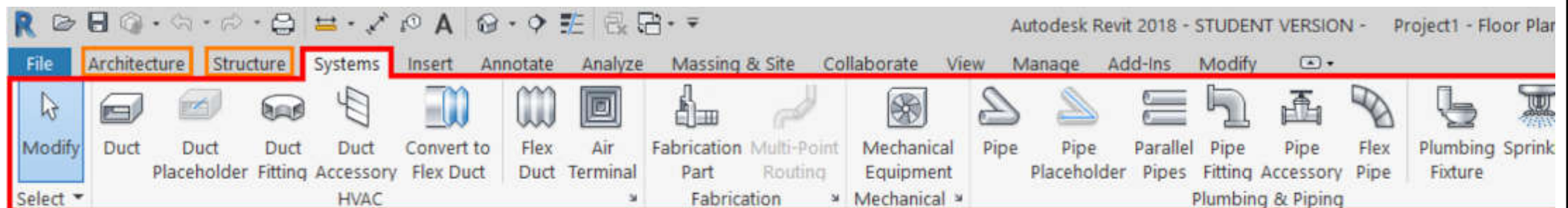



# Introduction

- Revit MEP techniques:
  - Starting Revit MEP projects\*
    - Link architectural model
    - Copy & monitor elements
    - Set up & modify levels
  - MEP systems
    - Create systems
    - Connect components
    - Create spaces, zones and colour schemes

You can experience  
& learn this in the  
practical training  
sessions.

# Introduction

- Revit MEP techniques: (cont'd)
  - Energy analysis
    - Analyse heating & cooling loads
    - Secondary analysis (e.g. air-side systems)
  - Piping systems (create & routing)
  - HVAC systems
    - Create systems, add air terminals & mechanical equipment, add ductwork, create & modify duct systems, automatic ductwork layouts

# Introduction

- Revit MEP techniques: (cont'd)
  - Electrical systems
    - Create systems, place electrical components, create electrical circuits, cable trays & conduit, electrical panel schedules
  - Annotate construction documents
    - Add detail lines & symbols
  - Tags & schedules
    - Add tags, create & modify schedules

# Introduction

- Revit MEP techniques: (cont'd)
  - Customize Revit (to improve productivity)\*
  - Customize Family & Project Templates
    - Build your own Starter Family Templates
    - Work with vendor equipment (import files)
    - Build your MEP Project Templates
  - Customize Families & Parameters
    - Know when to use family-based shared parameters versus project parameters based on shared parameters

Good templates will facilitate efficient work.

# Revit MEP tips



- MEP design considerations:
  - Start with an **overall** approach to your model
    - Systematic planning (integrate design & modelling)
    - Decide if **work sets** are required & set these up\*
  - Set up standards & **templates** (for Revit use)
  - Use of “**families**” (Revit) in a project
  - Level of details & design purpose
    - Start with boxes to represent the space of an item
  - Set up main branches, pipe runs etc. first

# Revit MEP tips



- What to model
  - Need to draw some lines as where to stop
  - Are some things not needed to be modelled?
  - Keep in mind how large your model is or will be
  - The more small detail, the slower the performance
  - Is the small detail ever going to be seen?
    - Level of details
  - Useful viewpoints, e.g. reflected ceiling plan



# Revit MEP tips

- Project Browser\* – View naming organization
  - Think about a plan of attack
  - Recommend setting a standard for view naming and sticking to it
  - Utilise the Project Browser's organisation and filters capability
  - Recommend sort by sub-discipline

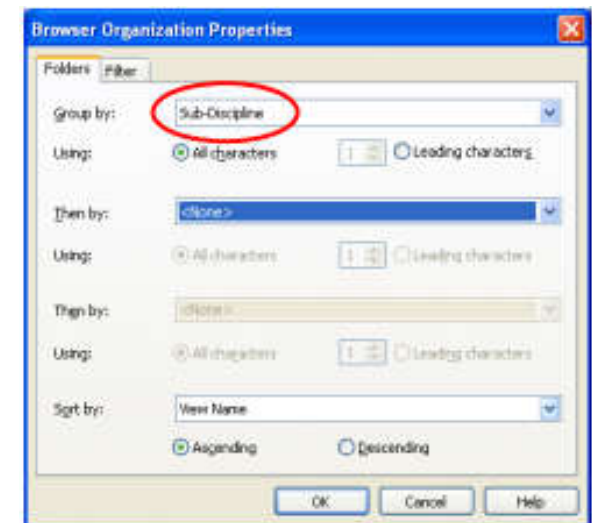

# Revit MEP tips



- Clash Detection

- Coordination models (with Navisworks)\*
- Run an interference check\*\*
- To access go to:
  - Tools > Interference Check >
  - Run Check
- All interferences will be located
- Can sometimes be a nuisance

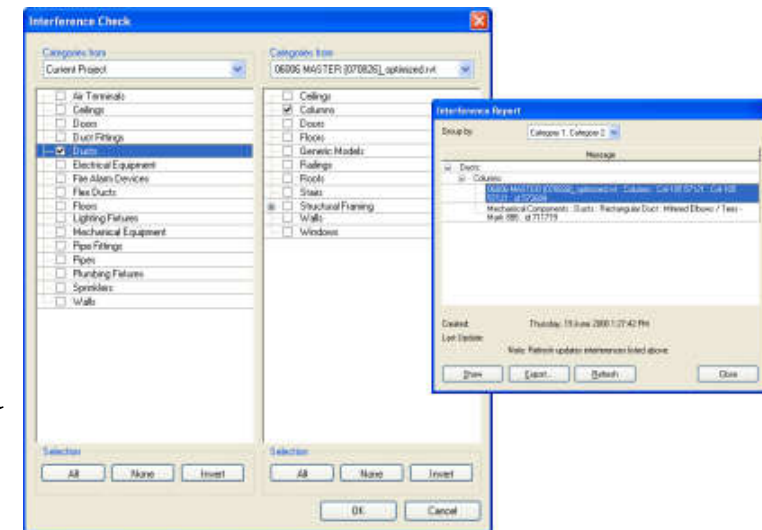

(\*See also: Coordination Models <http://help.autodesk.com/view/RVT/2018/ENU/?guid=GUID-4E489B91-C1C6-4733-AC82-3CE639F6A07A>;

\*\*Interference Checking <http://help.autodesk.com/view/RVT/2018/ENU/?guid=GUID-890A9FE0-EFF4-4CFB-9E81-B0DE1A132BEC>)

# Revit MEP tips



- Families\* – Tips & tricks
  - A family is a group of elements with a common set of properties, called parameters, and a related graphical representation
  - Use Family Editor to modify existing elements or create new ones to meet specific needs of a project
  - Be sure to start from the right family template
    - Ceiling based, wall based, floor based, face based
  - Work plane-based families:
    - Ability to place family items on any plane
  - Continually test the parameters (Flex the model)

Revit Families is important for design productivity.



# Revit MEP tips

- Schedules\* (lists of any type of element in a project)
  - Will update with changes made to the elements in the model (e.g. electrical panel schedules)
  - Ability to add/remove columns, ability to format
- Spaces\*\*
  - Create spaces to run heating & cooling load analysis (including plenums & shafts)
  - Ability to reference room names & numbers from linked model with space tags

(\*See also: Schedules <http://help.autodesk.com/view/RVT/2018/ENU/?guid=GUID-F50D6FF4-859E-43A2-A2F6-81C84A1BA0EB>;

\*\* Spaces <http://help.autodesk.com/view/RVT/2018/ENU/?guid=GUID-48509199-F248-4B61-9DC6-CEFBE2E302F2>)

# Revit MEP tips



- Documentation

- To communicate the design intent to team members, consultants, clients, and contractors
  - Such as project views, schedules, project phasing, annotation, detailing, construction documents
- Prepare company standards & set up standard template you desire
- Utilizing 2 views overlaid on each other
- Pinning the view on a sheet (2D drawing)

# MEP documentation (examples)

3D Model

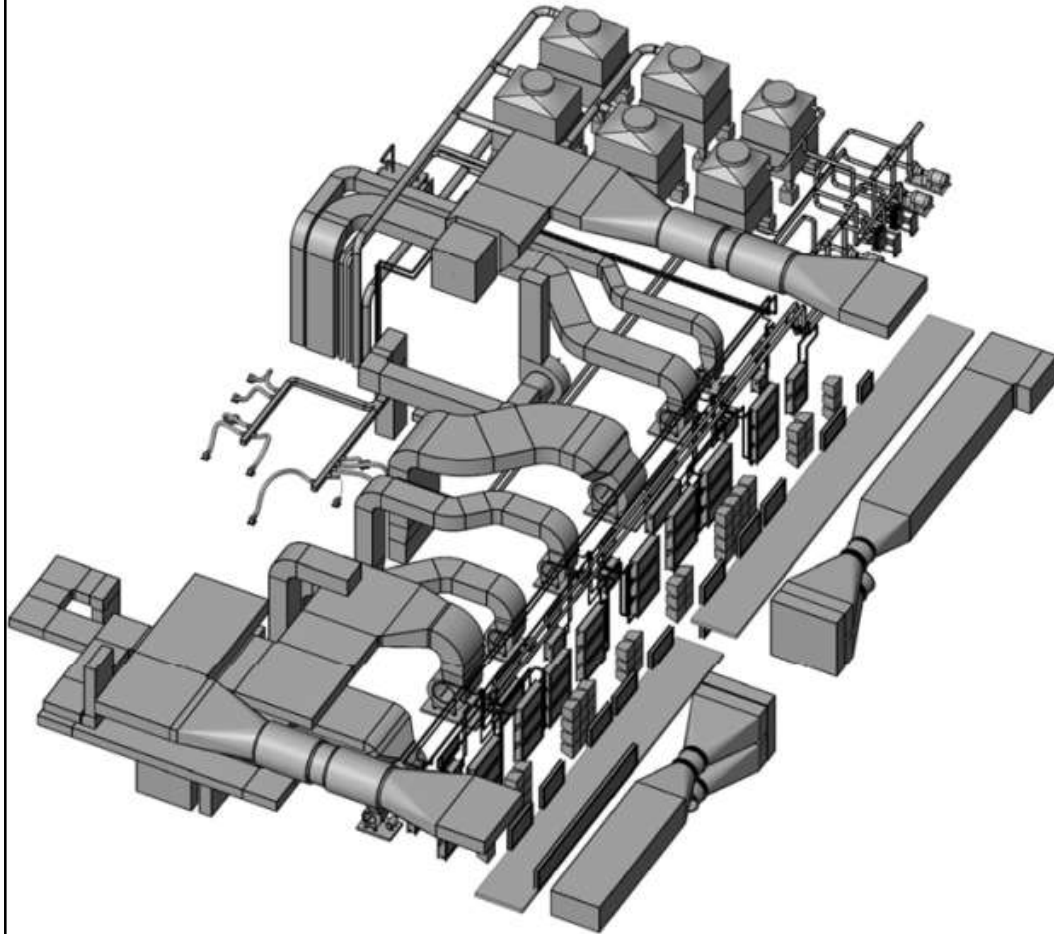

2D Documentation

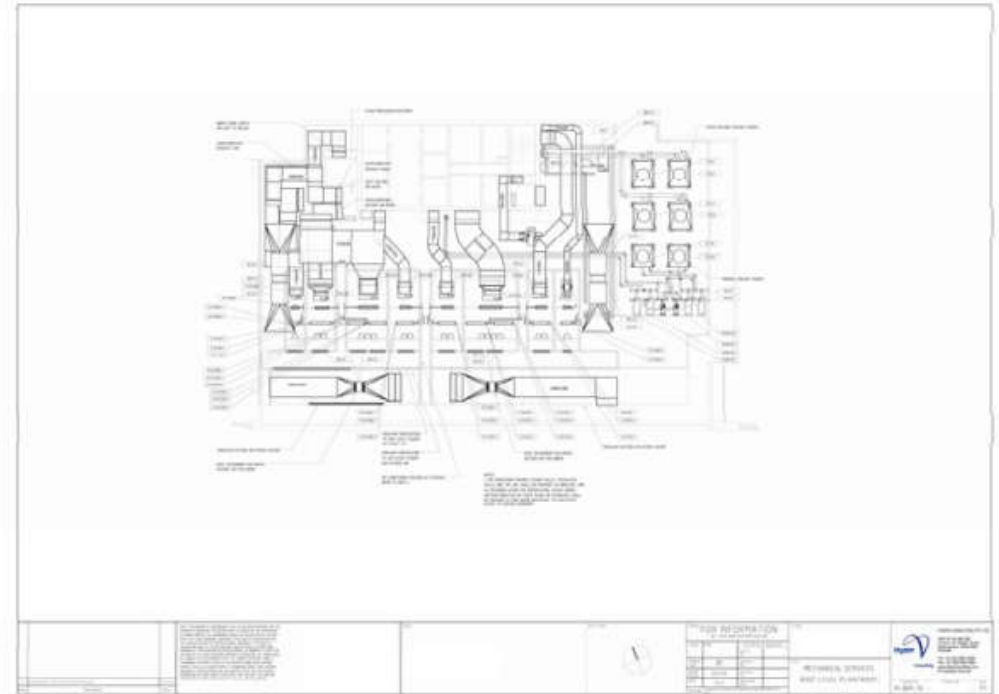

2D drawing for plantroom

# MEP documentation (examples)

## 3D Model

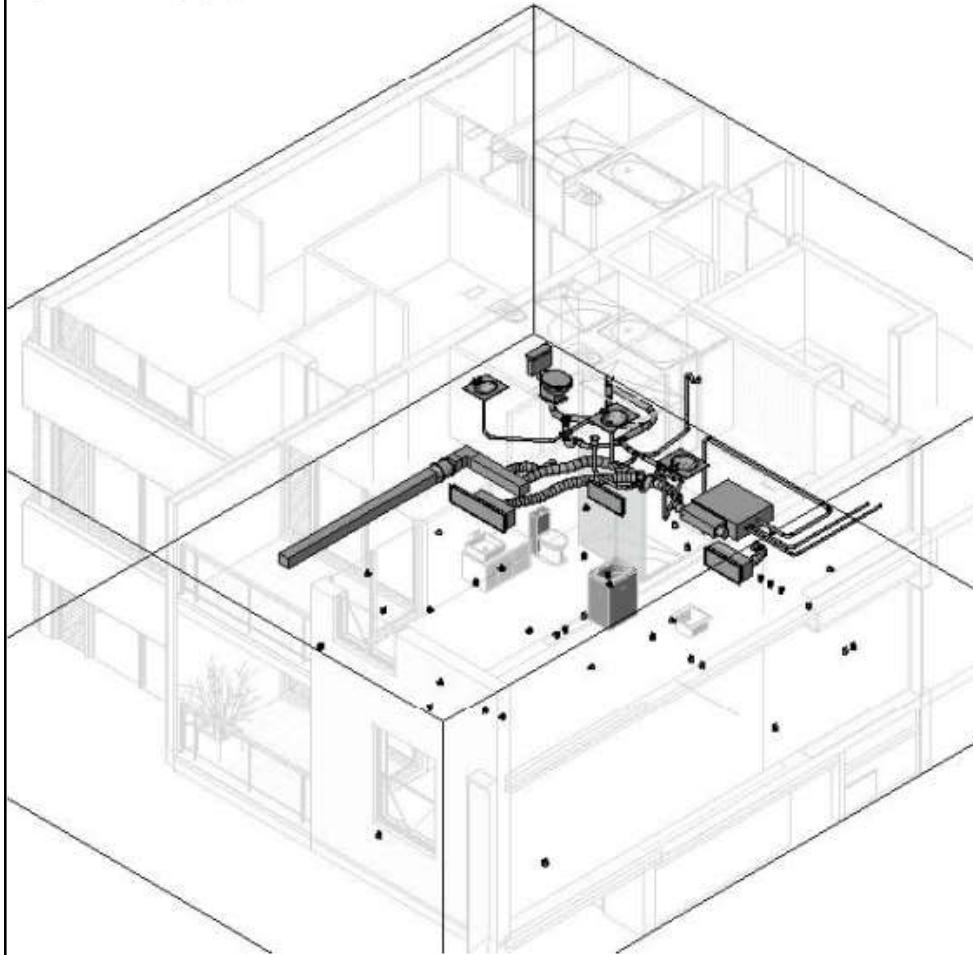

## 2D Documentation

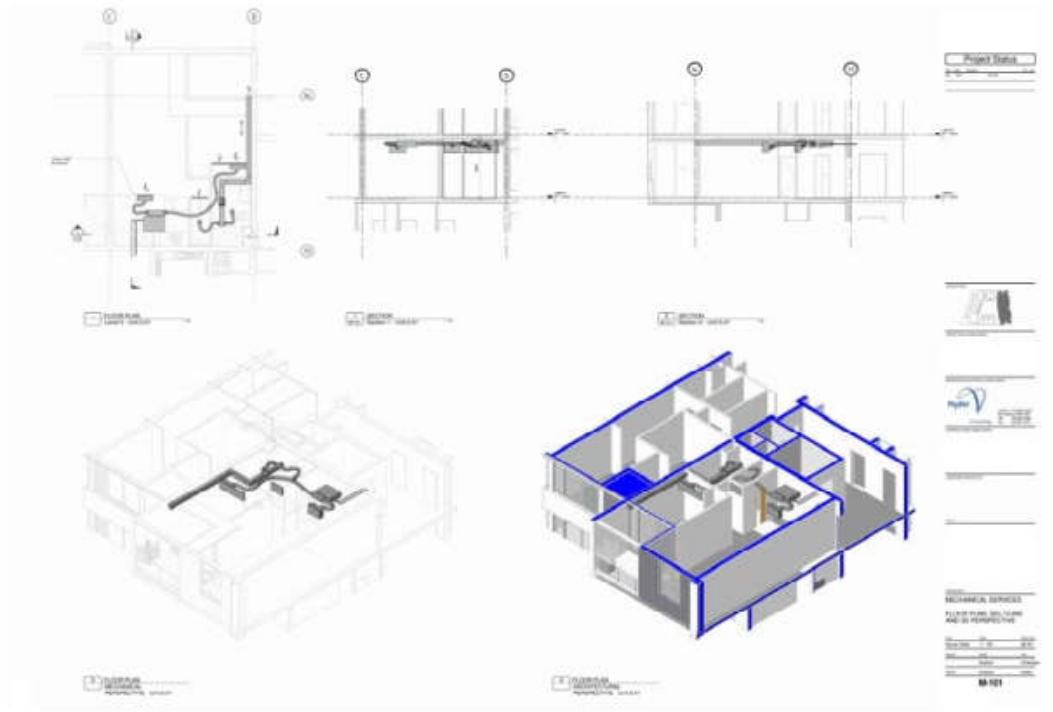

Drawings for different views

Do you know how to  
communicate & present  
your BIM MEP models?

# Revit MEP tips



- Working with IFC format In/Out of Revit
  - Such as: Architect produces model in ArchiCAD & ArchiCAD model exported out to IFC format
    - Integrity of IFC model checked in Solibri model checker & file size is reduced
  - IFC model is imported into Revit and linked into MEP model; MEP main design elements produced (duct work, piping etc) in 3D
  - MEP model exported back to IFC and issued back to Architect, along with DWF



# Revit MEP tips



- Working with IFC format In/Out of Revit
  - Coordination and collaboration using Navisworks
  - All details & schematics were produced in AutoCAD
  - Still a way to go for 100% integrity of IFC model geometry
    - Export/Import settings limited in both Revit & ArchiCAD
    - File size of Arch model once imported to Revit is quite large (200MB+)

# Revit MEP tips



- Navisworks\* & rendering\*\*
  - Formatting schedules
  - Coordination with other file types (e.g. IFC, DWG, DXF, SAT)
  - Coordination models & clash detection
  - Quick review of models for non-CAD users
  - Rendering & animations
    - Create a photorealistic image of the building model
    - Lighting simulation & raytracing technique

(\*See also: Navisworks <https://www.autodesk.com/products/navisworks/>;

\*\* Rendering <http://help.autodesk.com/view/RVT/2018/ENU/?guid=GUID-4046977A-9323-4535-9AC0-4EF9A138A5A6>)

# Creating logical systems

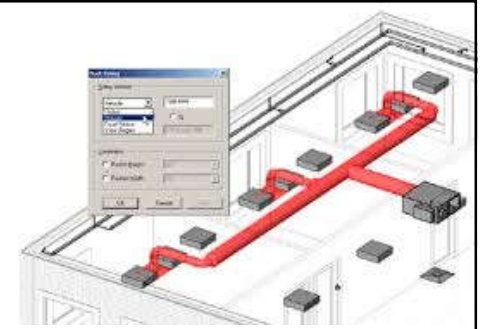

- Systems

- They represent the transfer of information between families. They range from supply air to refrigerants to laboratory gases to anything else a building needs to operate
- They are the logical connection between elements in the model
  - They are the link between the air terminal, the variable air volume (VAV) box, and the air handler, and they represent an additional layer of information above the physical connections made with duct and pipe

# Selecting duct systems in the System Browser

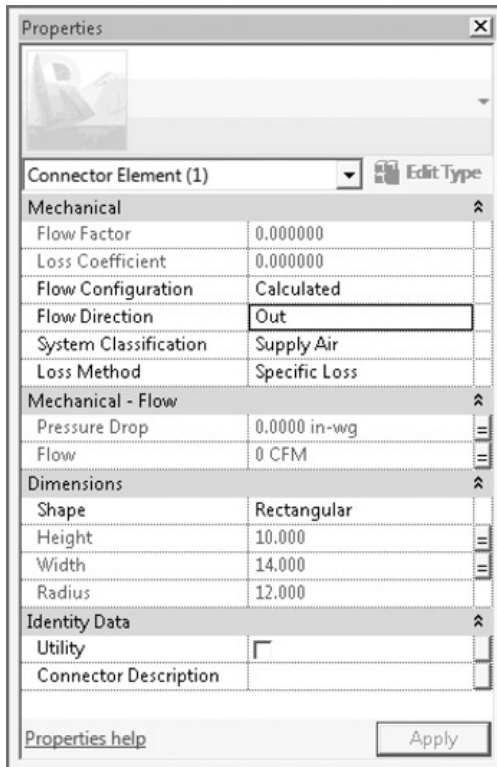
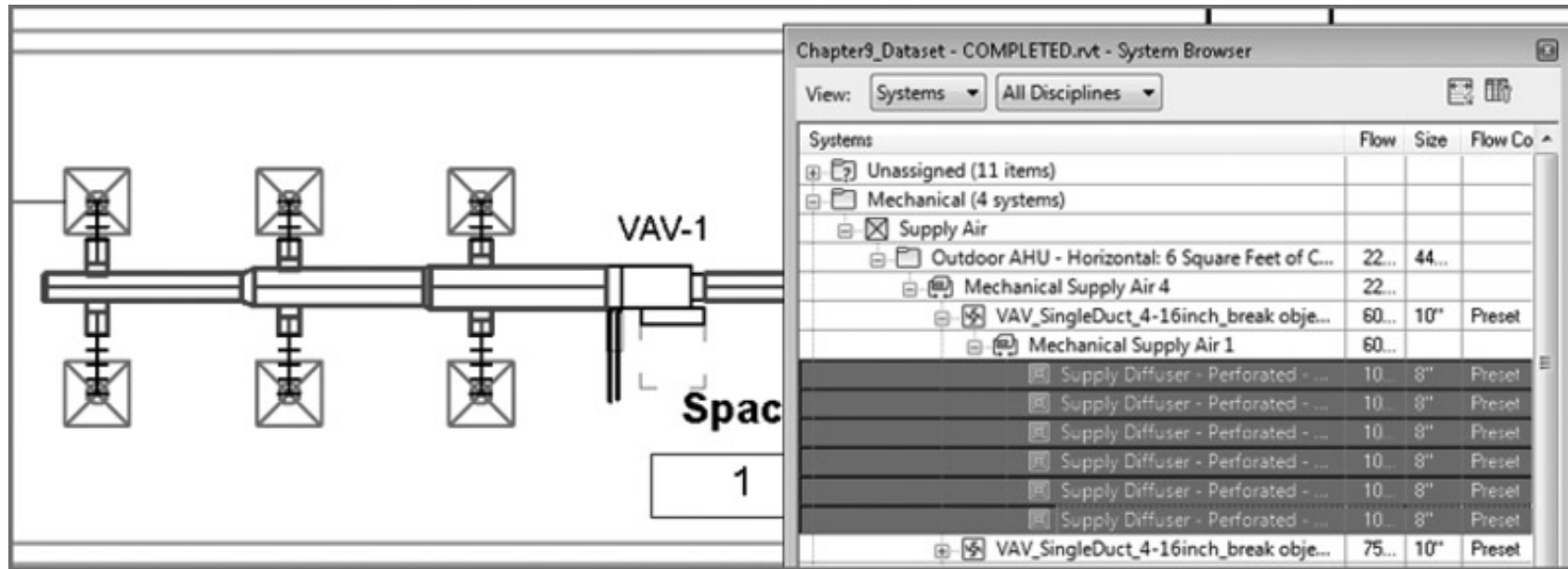

Parameters for duct connection

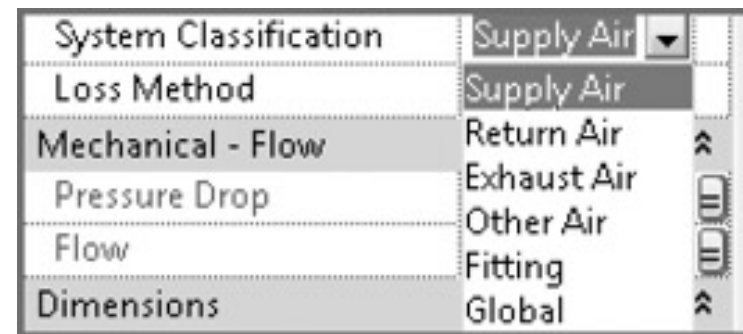

System classifications for duct connections

# Set up piping (hydronic) systems & display properties (for HVAC, plumbing & fire protection)

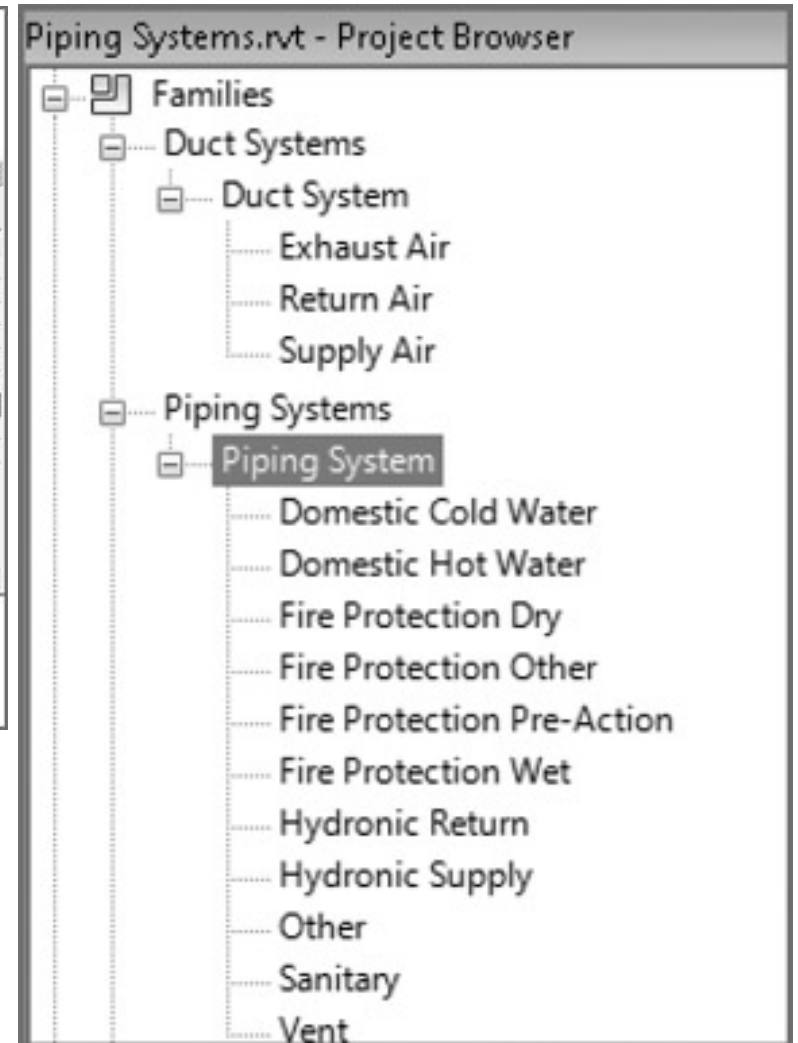
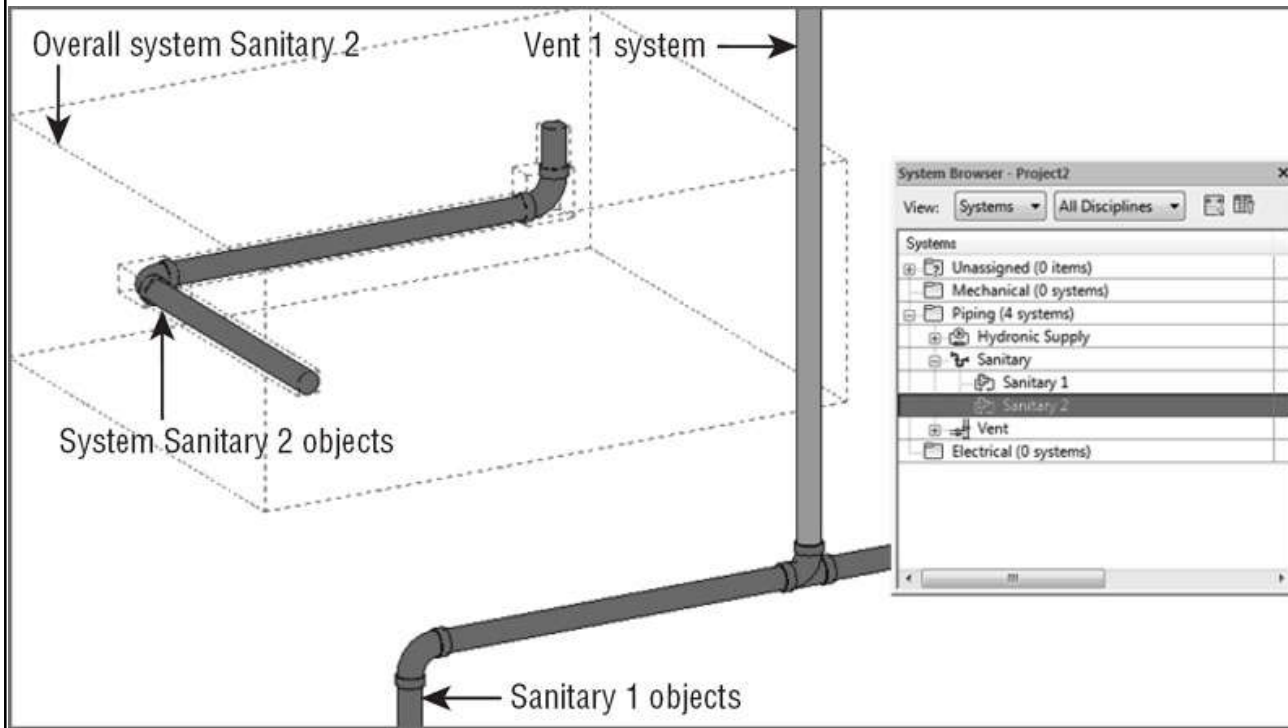

By understanding how to change and manage piping systems, the user can create and maintain different systems effectively



# Creating logical systems

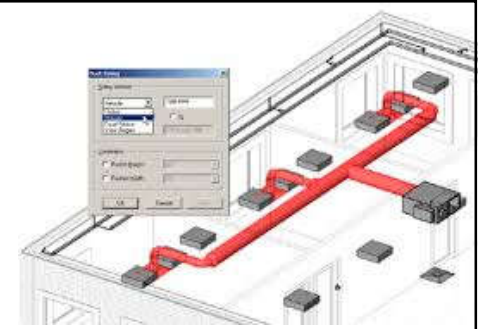

- Using System Filters

- Control over the visibility of certain elements in views & the appearance those elements will have
- Filters help us create high-quality documentation as well as providing a better way to examine our design and improve the coordination of our projects
- Mastering filter options enables you to create your models with the standards that your office has developed over years of producing CAD drawings

# Using System Filters

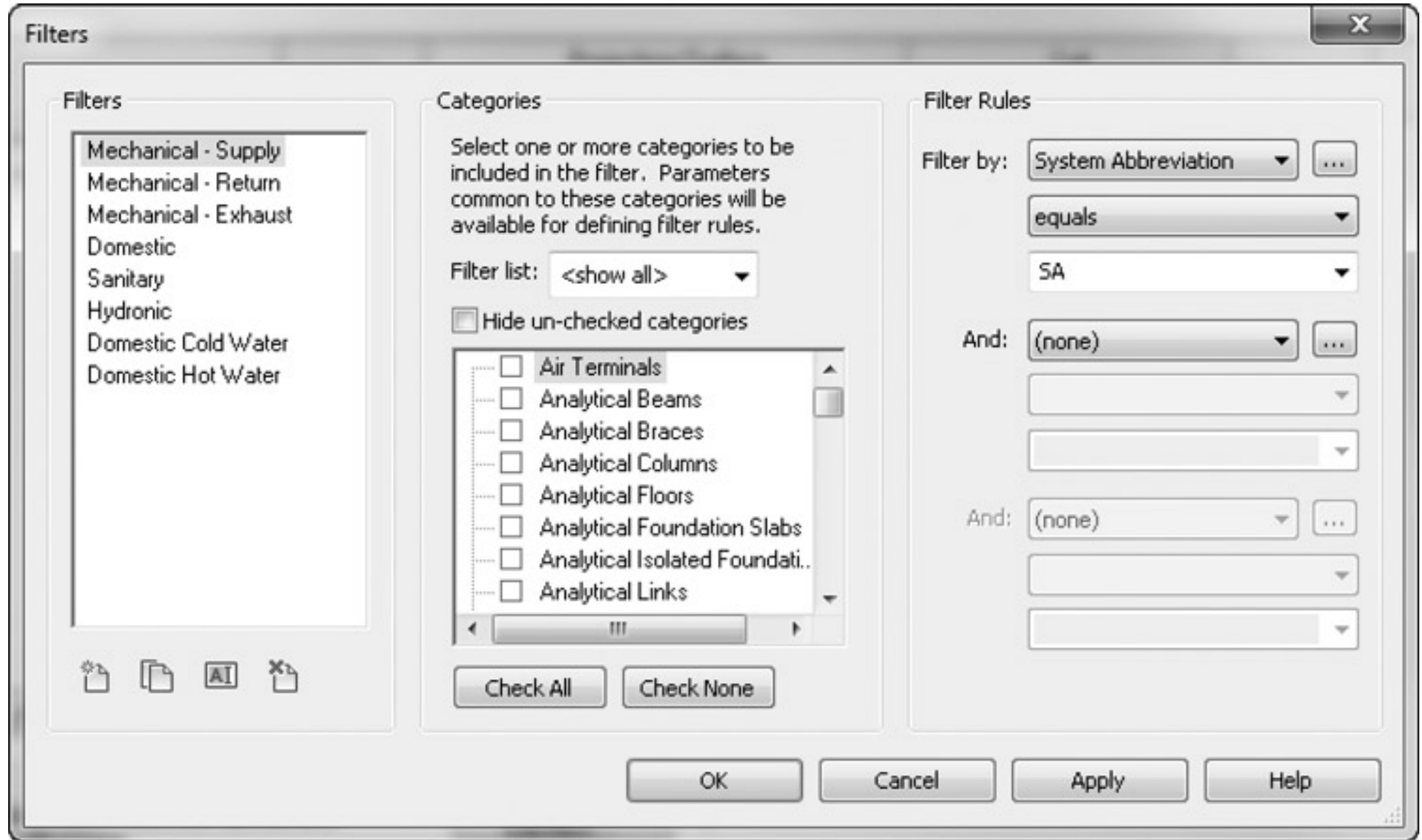

# Mechanical systems & ductwork

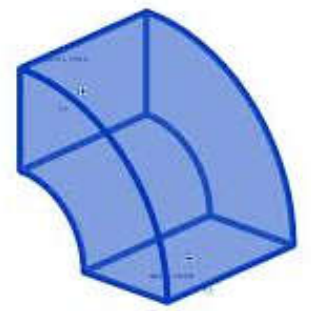

- Ductwork\*

- Duct is presented as a single line at concept design or as a fully coordinated double line for a construction issue
- Three main types: rectangular, round, and oval

- Air distribution components

- Diffusers in a ceiling, duct-mounted sidewall diffusers, wall mounted, suspended
- Diffuser hosting methods in Revit

# Diffuser hosting methods

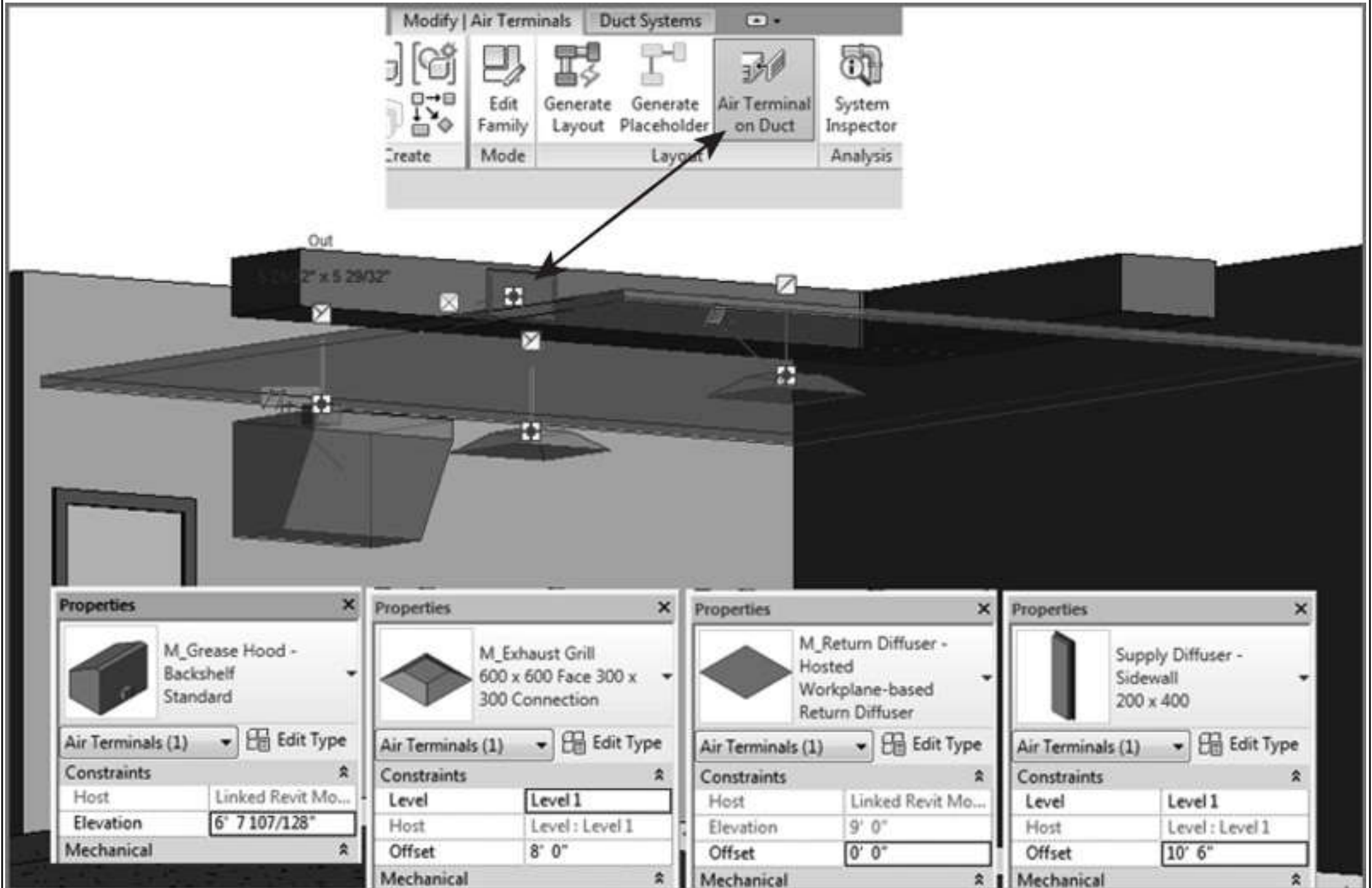

# Mechanical systems & ductwork

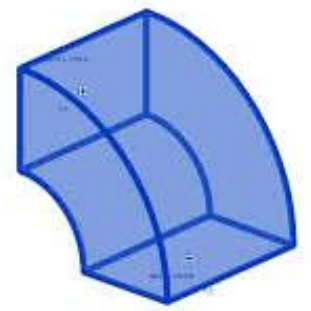

- Mechanical equipment components

- Air conditioning/handling units
  - Floor mounted, skid mounted (w/ an offset or rail)
- VAV boxes
  - Connection to water (chilled/hot) & electrical systems
- Ductwork
  - Create using Duct Tool or Placeholder Duct Tool
  - Break up large systems to avoid slowing down the design process
  - Interference check for ducts and pipes

# Basic AHU and type parameters

**Properties**

Outdoor AHU - Horizontal  
6 Square Feet of Coil

Mechanical Equipment (1) Edit Type

**Constraints**

Level	Level 1
Host	Level : Level 1
Offset	0' 9 1/2"

**Electrical - Loads**

Panel	
Circuit Number	

**Mechanical**

Hot Water Pressure Drop	1.805 psi
External Total Pressure	2.8900 in-wg
Hot Water Flow	25 GPM
Chilled Water Pressure ...	2.887 psi
Chilled Water Flow	43 GPM
System Classification	Supply Air, Return Air, Sup...
System Name	Mechanical Supply Air...

**Mechanical - Flow**

Supply Air Outlet Flow	3000 CFM
Supply Air Inlet Flow	2000 CFM
Return Air Inlet Flow	1000 CFM

**Identity Data**

Properties help Apply

# Ductwork

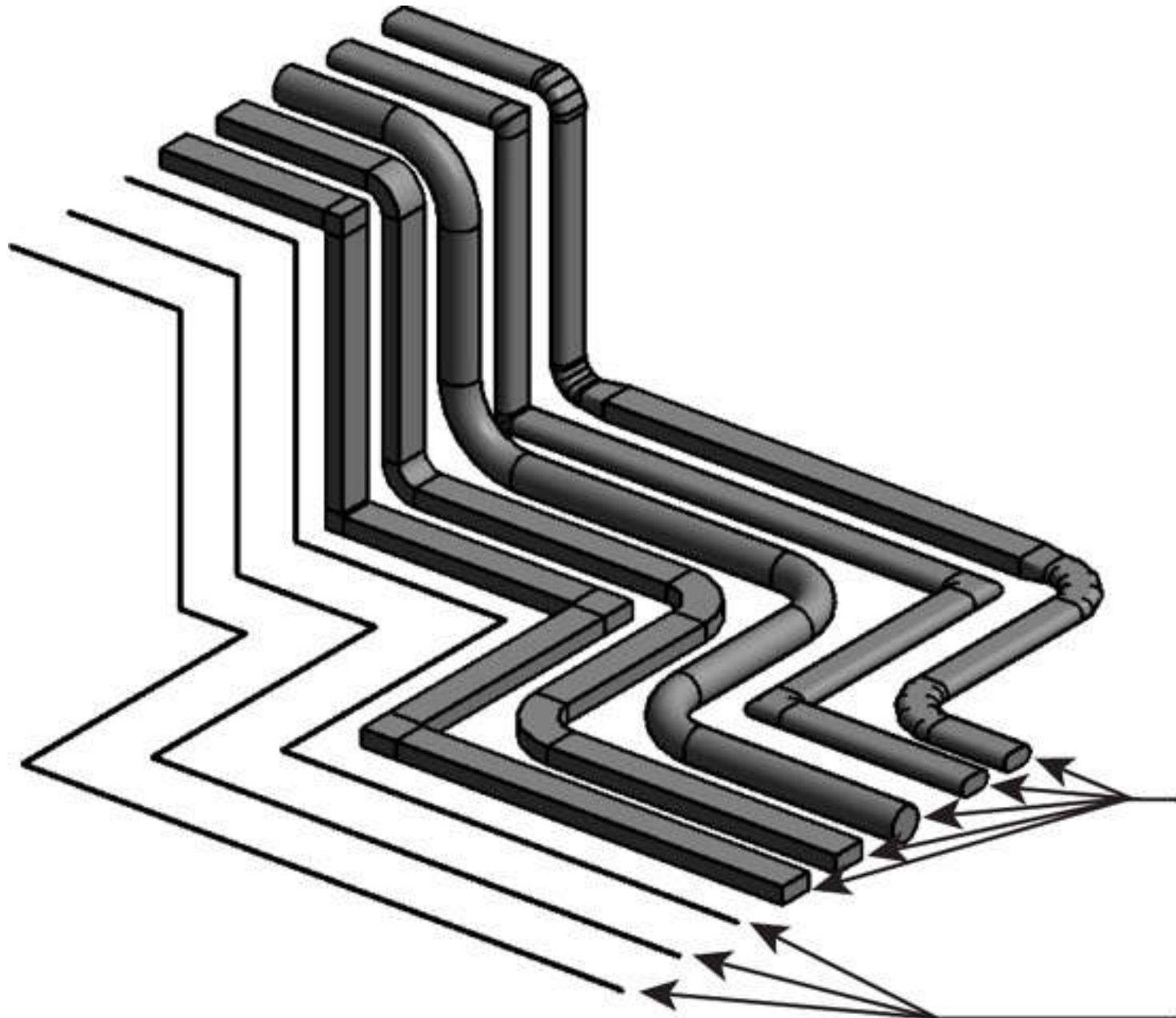

## Ducts

Oval—gored bends

Oval—mitred bends

Round

Rectangular—radius bends

Rectangular—mitered bends

## Placeholder Ducts

Oval

Round

Rectangular

# Divide system using System Browser

The image shows the Revit MEP software interface. The ribbon is set to 'Modify | Duct Systems'. The 'Divide System' tool is highlighted in the 'System Tools' group. The main view displays a duct system layout with several supply air systems. The System Browser on the right shows a tree view of systems, with 'Mechanical Supply Air 15' selected. The System Browser table is as follows:

Systems	Flo
Unassigned (278 items)	
Mechanical (28 systems)	
Exhaust Air	
Return Air	
Supply Air	
M_WSHP - Horizontal - High Eff...	22
M_WSHP - Horizontal - High Eff...	48
M_WSHP - Horizontal - High Eff...	44
Mechanical Supply Air 15	44
M_Supply Diffuser - Rec...	11
M_Supply Diffuser - Rec...	11
M_Supply Diffuser - Rec...	11
M_Supply Diffuser - Rec...	11
Mechanical Supply Air 1	11
Mechanical Supply Air 2	87
Mechanical Supply Air 4	90
Mechanical Supply Air 5	35
Mechanical Supply Air 7	68
Mechanical Supply Air 8	77
Mechanical Supply Air 9	35
Mechanical Supply Air 10	72
Mechanical Supply Air 11	54
Mechanical Supply Air 12	54
Mechanical Supply Air 13	56
Mechanical Supply Air 14	60
Piping (17 systems)	

# Mechanical systems & ductwork

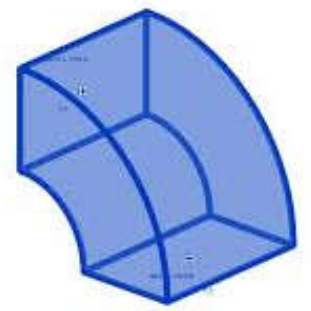

- Duct types & routing\*
  - Create duct types (Extract and Supply)
  - Schematic layouts
  - Automatic duct routing
  - Manual duct routing
  - Adjust fittings & extend the design

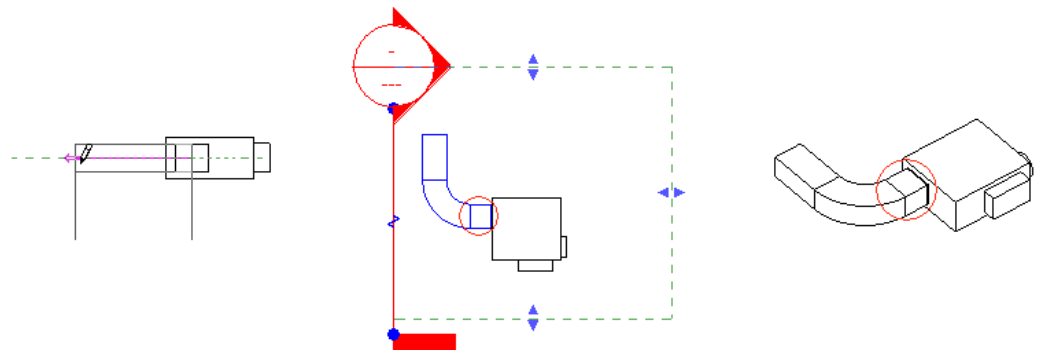

# Automatic duct routing & manual editing

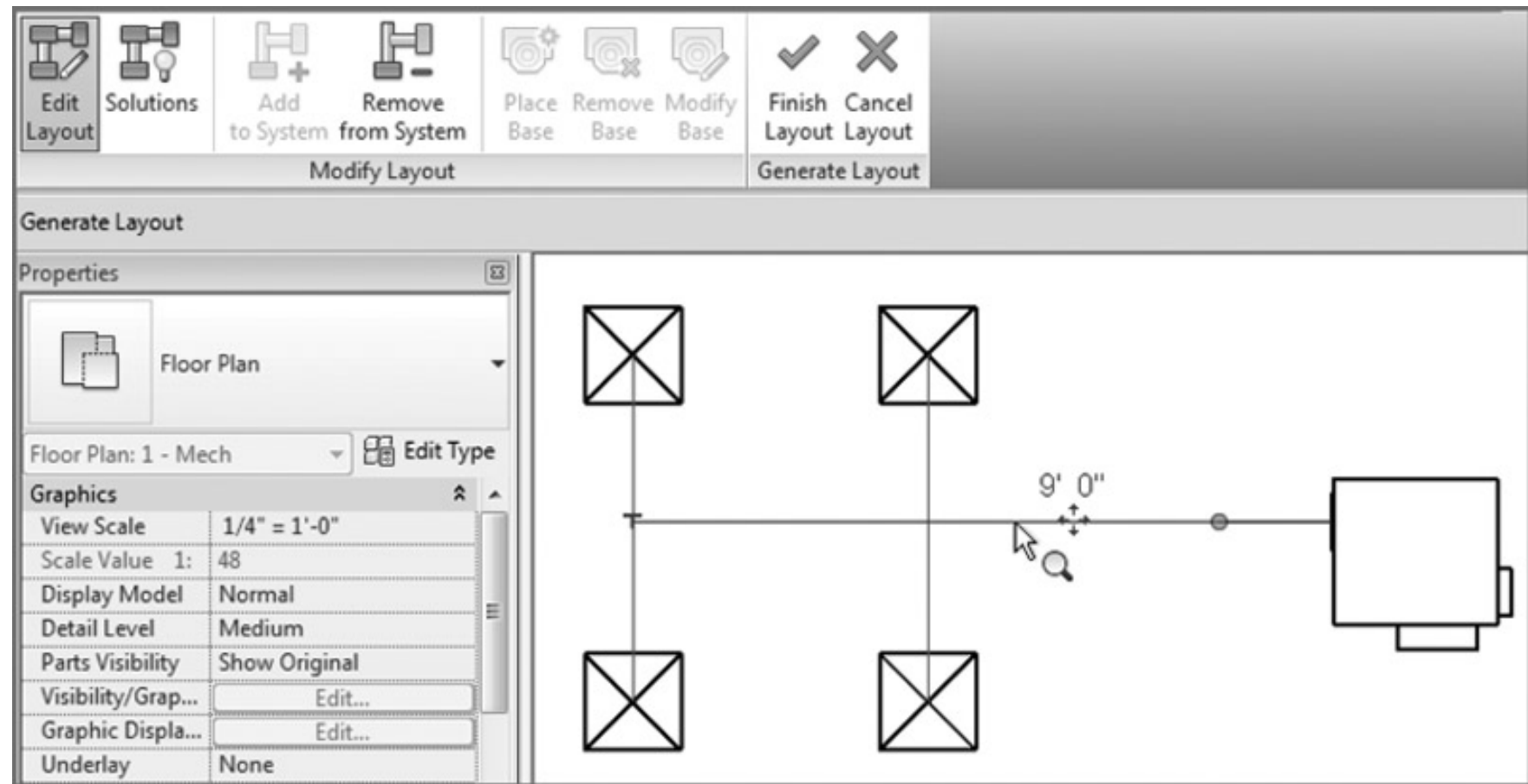

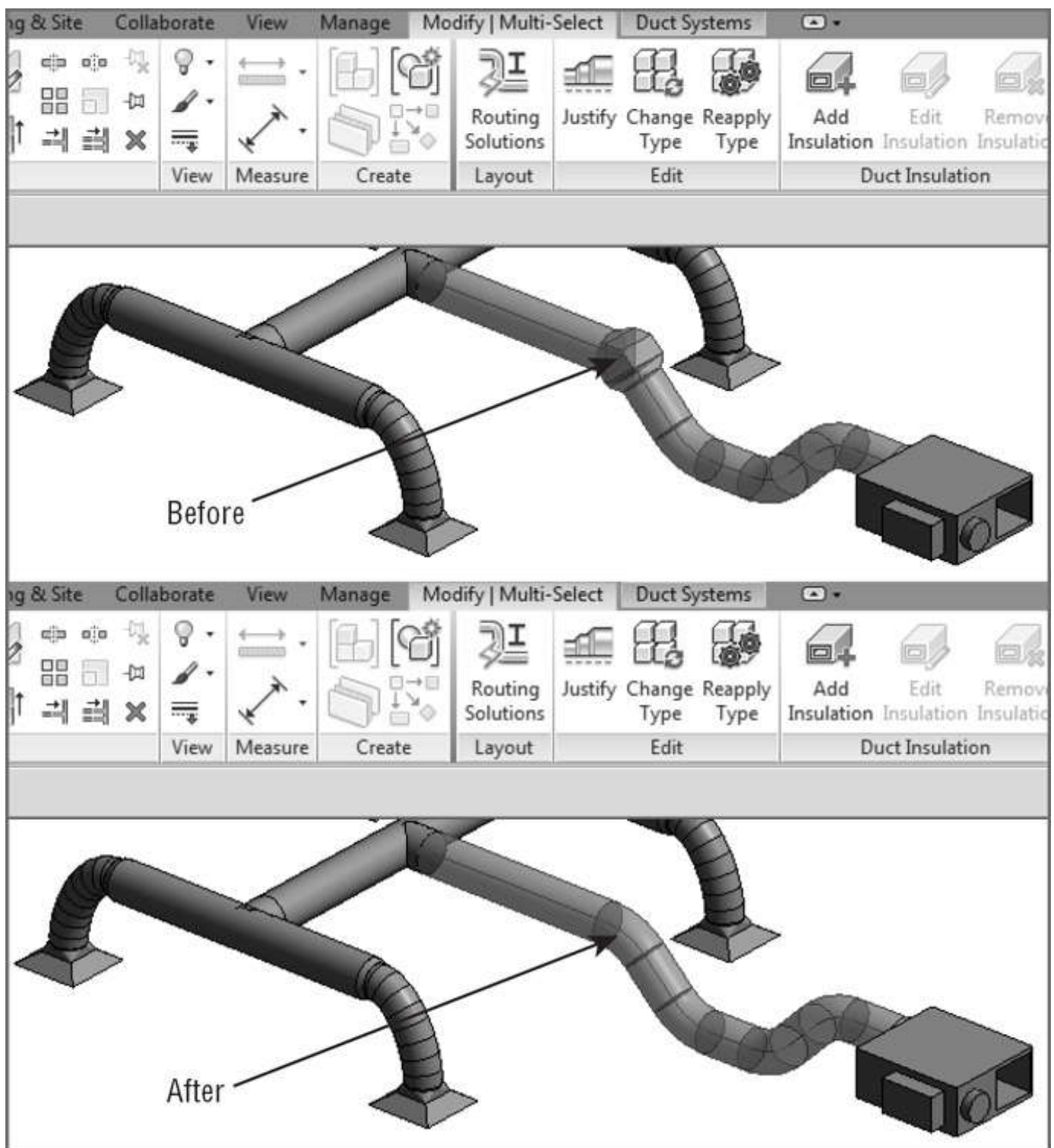

Adjusting & modifying duct fittings

# Mechanical systems & ductwork

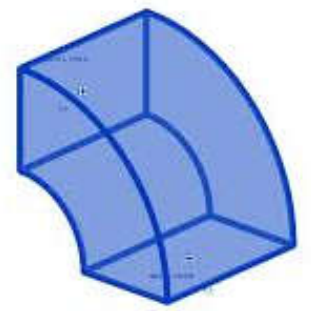

- Duct sizing\*
  - Choosing a duct sizing method (see HVAC notes)
    - Friction
    - Velocity
    - Equal friction
    - Static regain
  - Add duct insulation & lining
- System Inspector tool: to inspect the duct system for airflow, pressure, and pressure loss

# Duct sizing tool

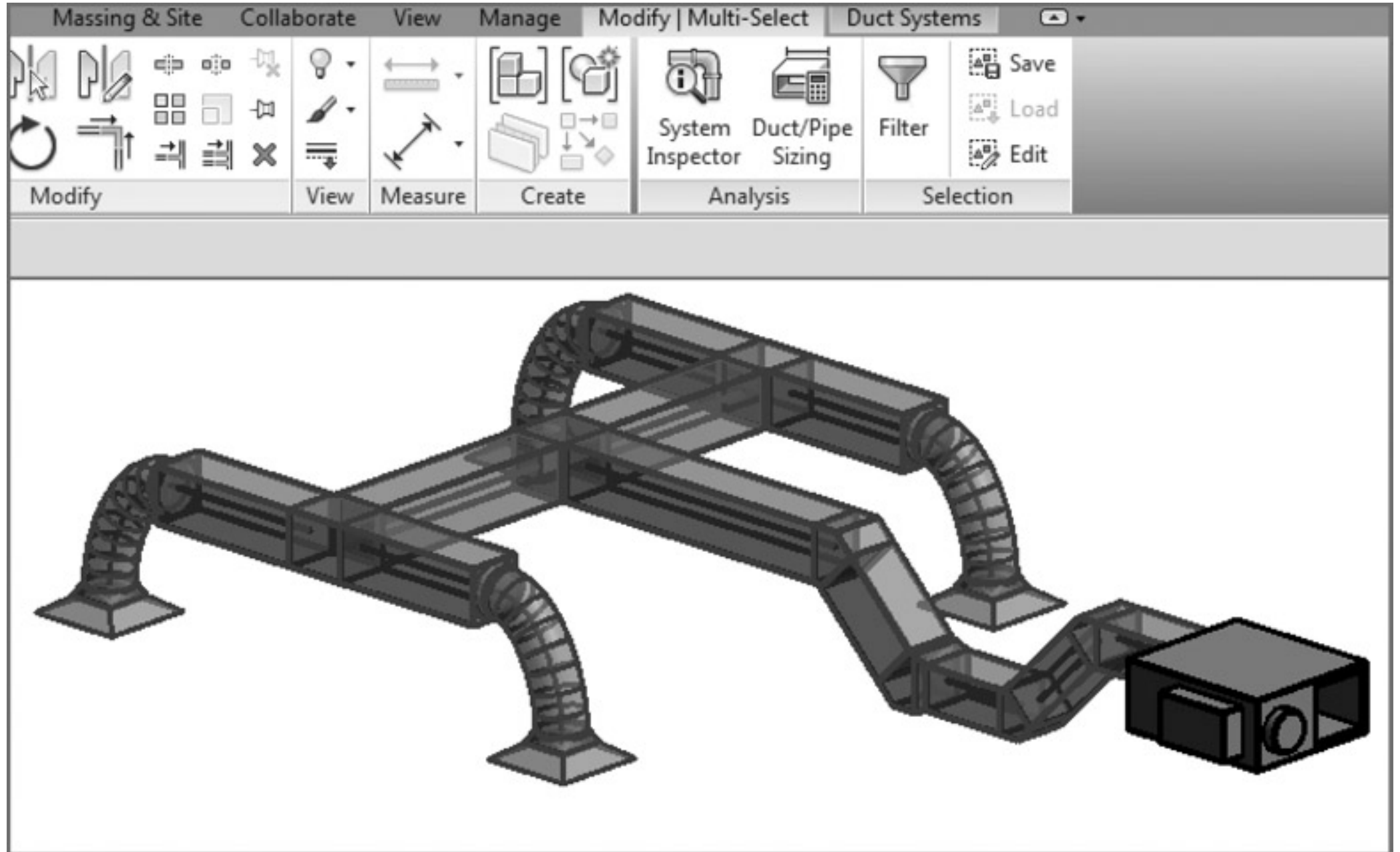

# Mechanical piping



- Piping systems\*

- Simple two-pipe or complex multi-pipe
- Pipe settings:
  - Piping systems
  - Pipe types (materials & fittings)
  - Pipe segments & sizes (nominal sizes)
  - Fluid table (for sizing pipes, determine pressure drop)
  - Slope table
  - Fitting angles

6' 0"

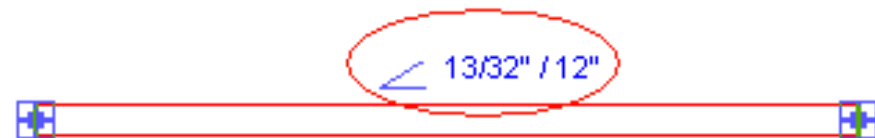

6' 3"

# Creating piping systems

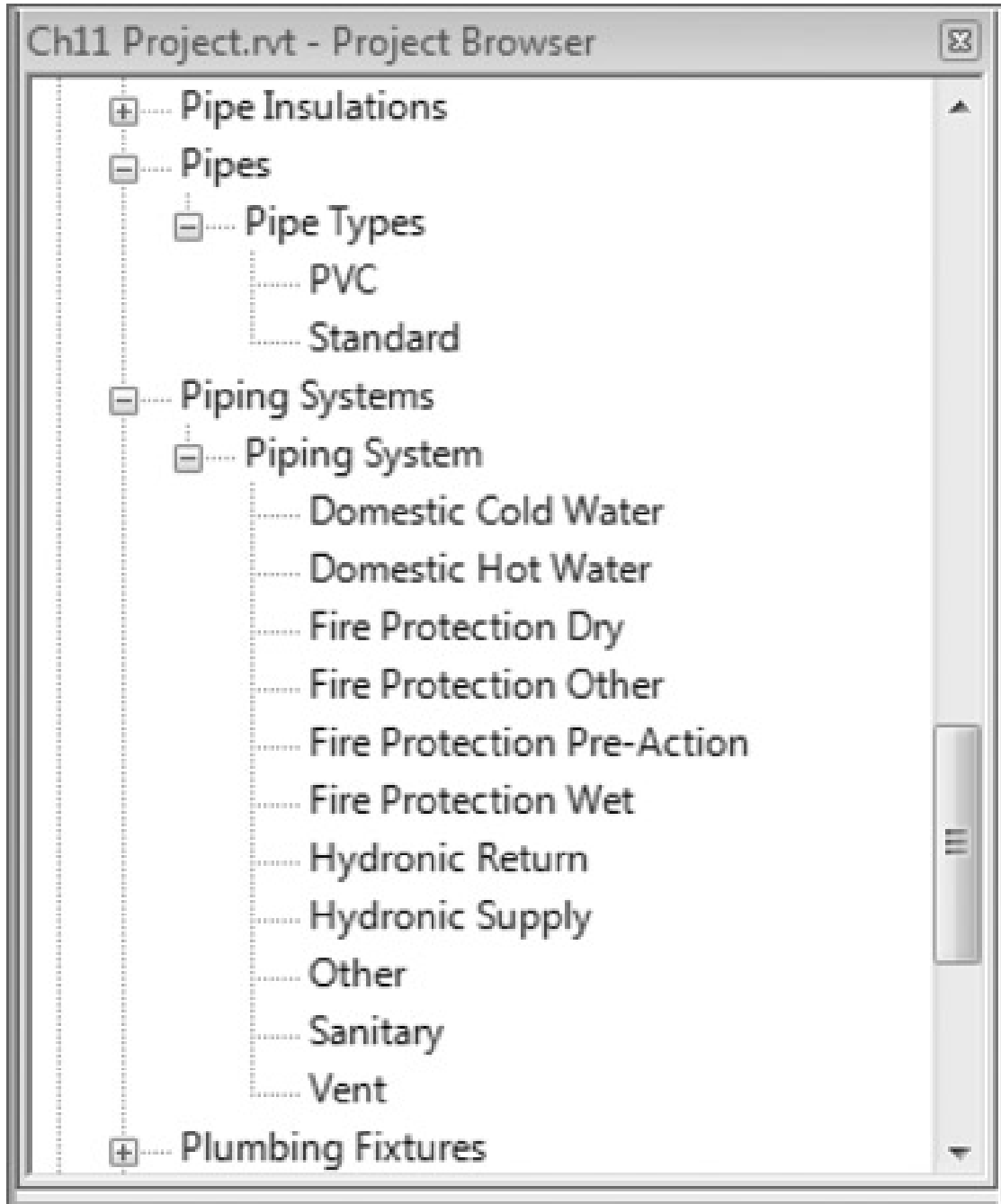

## Domestic piping systems:

- Domestic cold water
- Domestic hot water
- Sanitary
- Vent

## Fire-protection piping systems:

- Fire protection dry
- Fire protection wet
- Fire protection pre-action
- Fire protection other

## Mechanical piping systems:

- Hydronic return
- Hydronic supply

## Other (e.g. medical gas)

# Mechanical piping

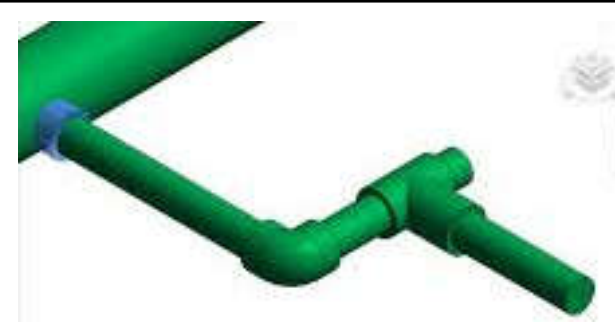

- Pipe routing options:

- Automatic pipe routing
- Manual pipe routing

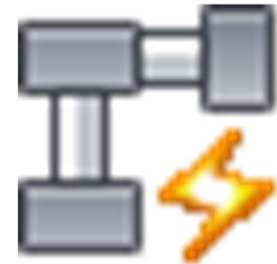

- Design tips:

- Colour-coded systems & interference checking
- Use project templates in piping layouts to improve productivity
- Automate with pipe connectors & improve coordination

# Create & edit piping systems

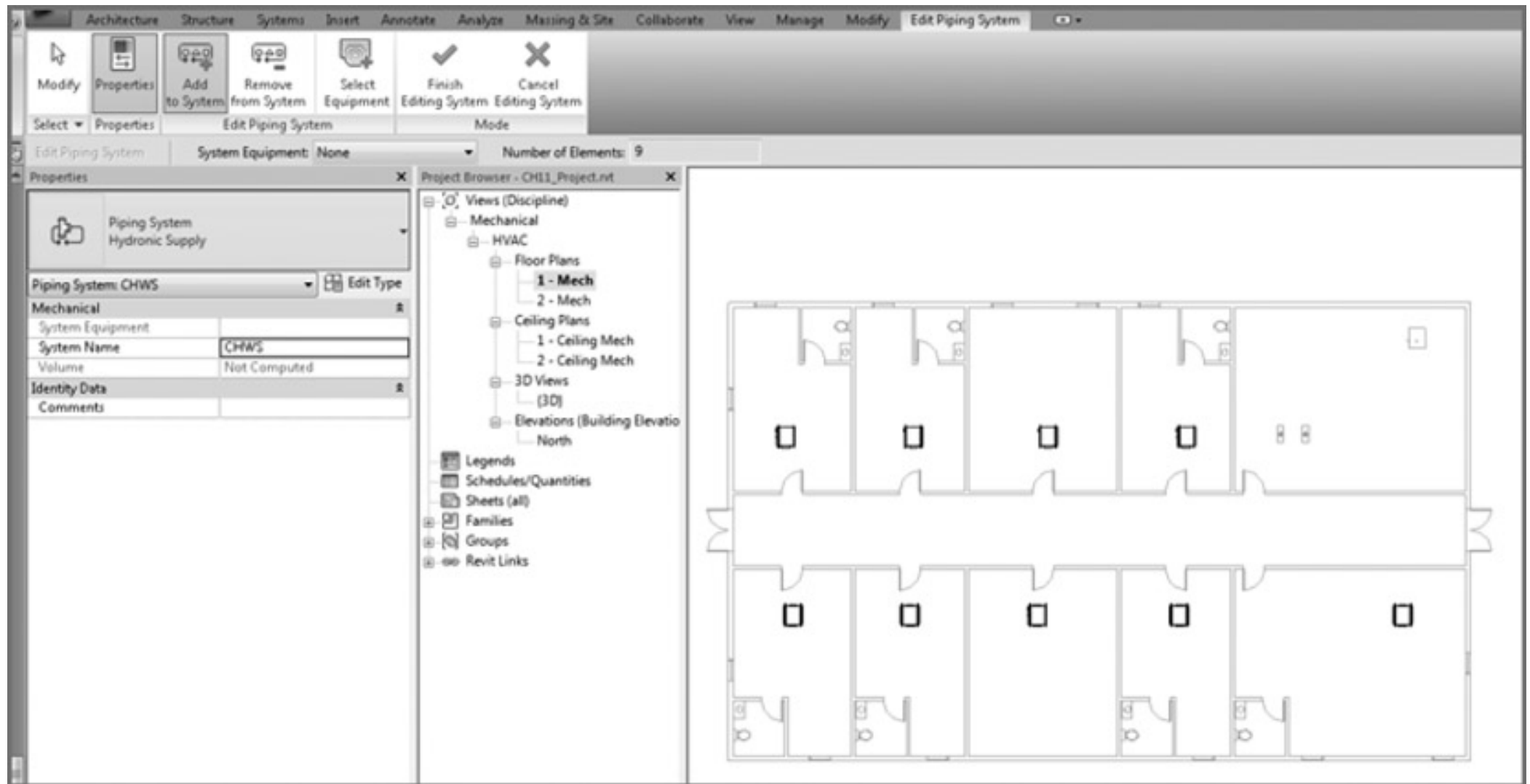

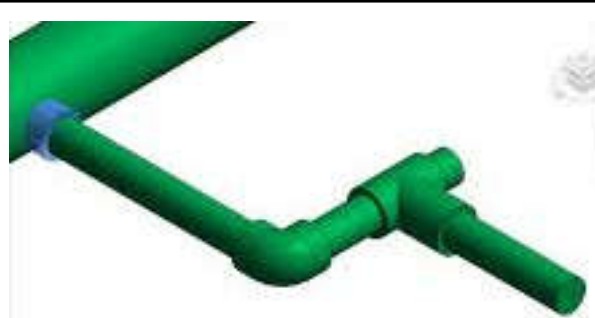

# Mechanical piping

- Pipe fittings
  - End caps
  - Tee, tap, wye or cross
  - Transitions, couplings, or unions
  - Flange
- Placing valves
- Adding piping insulation
- Defining systems visibility through filters

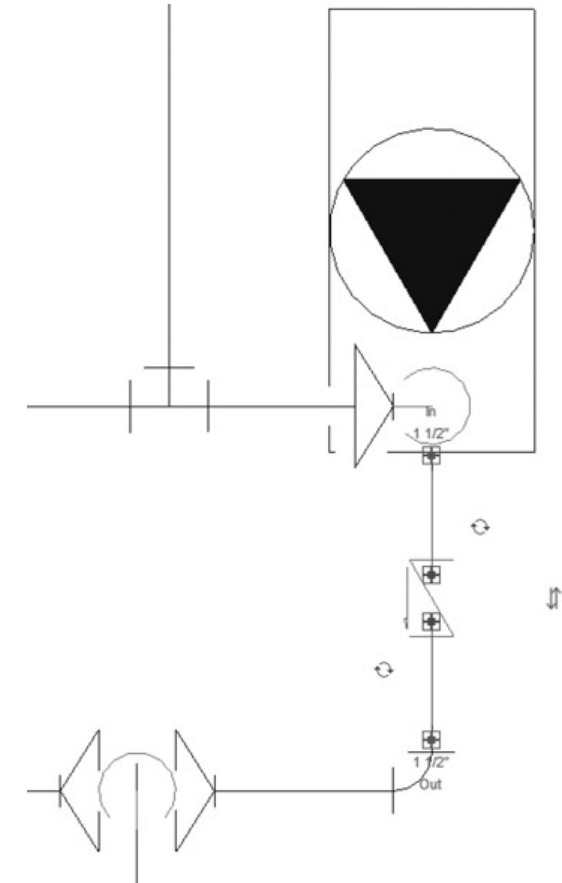

The same model displayed without filter overrides (on the left) and with overrides (to the right)

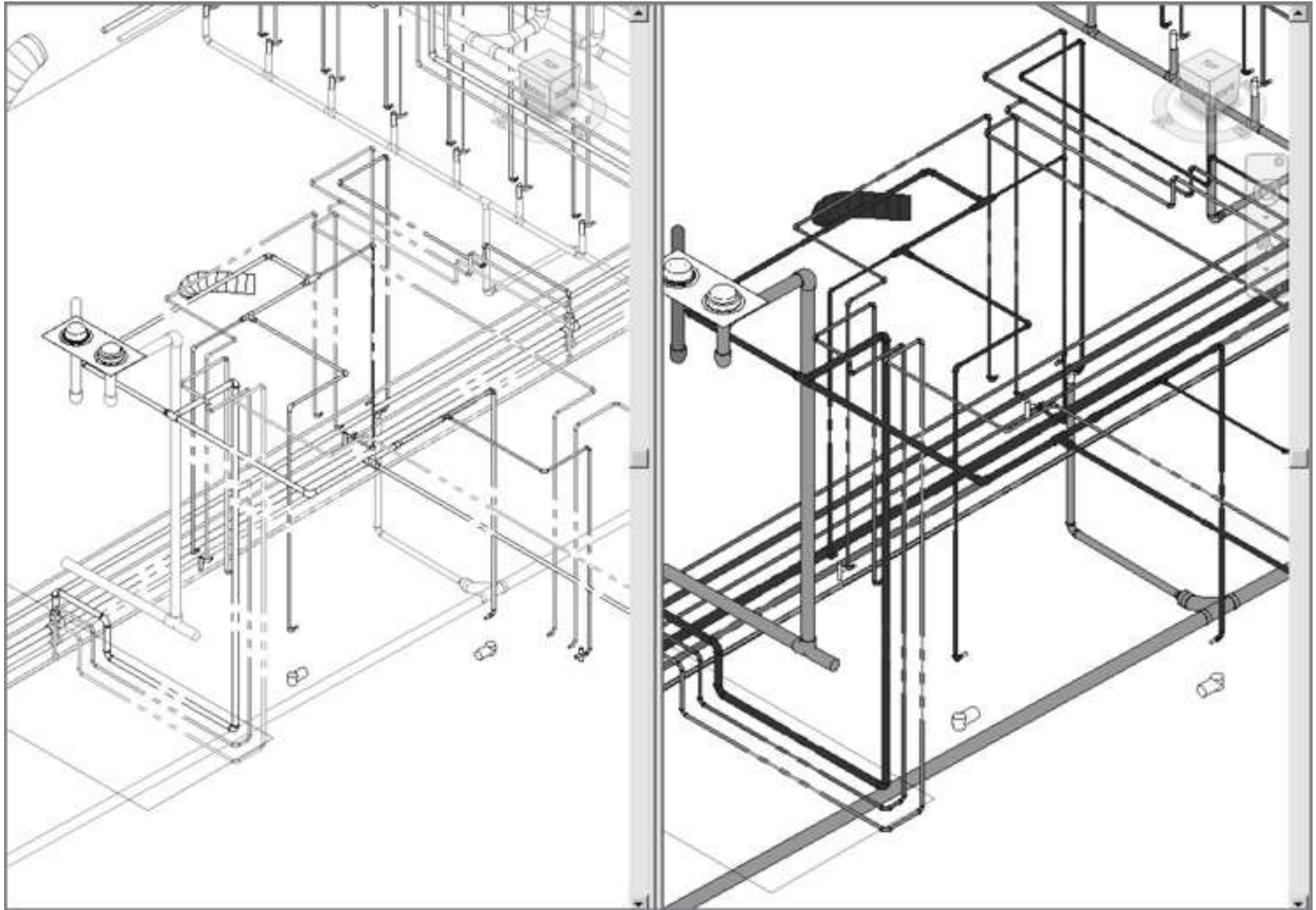

# Different views of hydronic piping systems

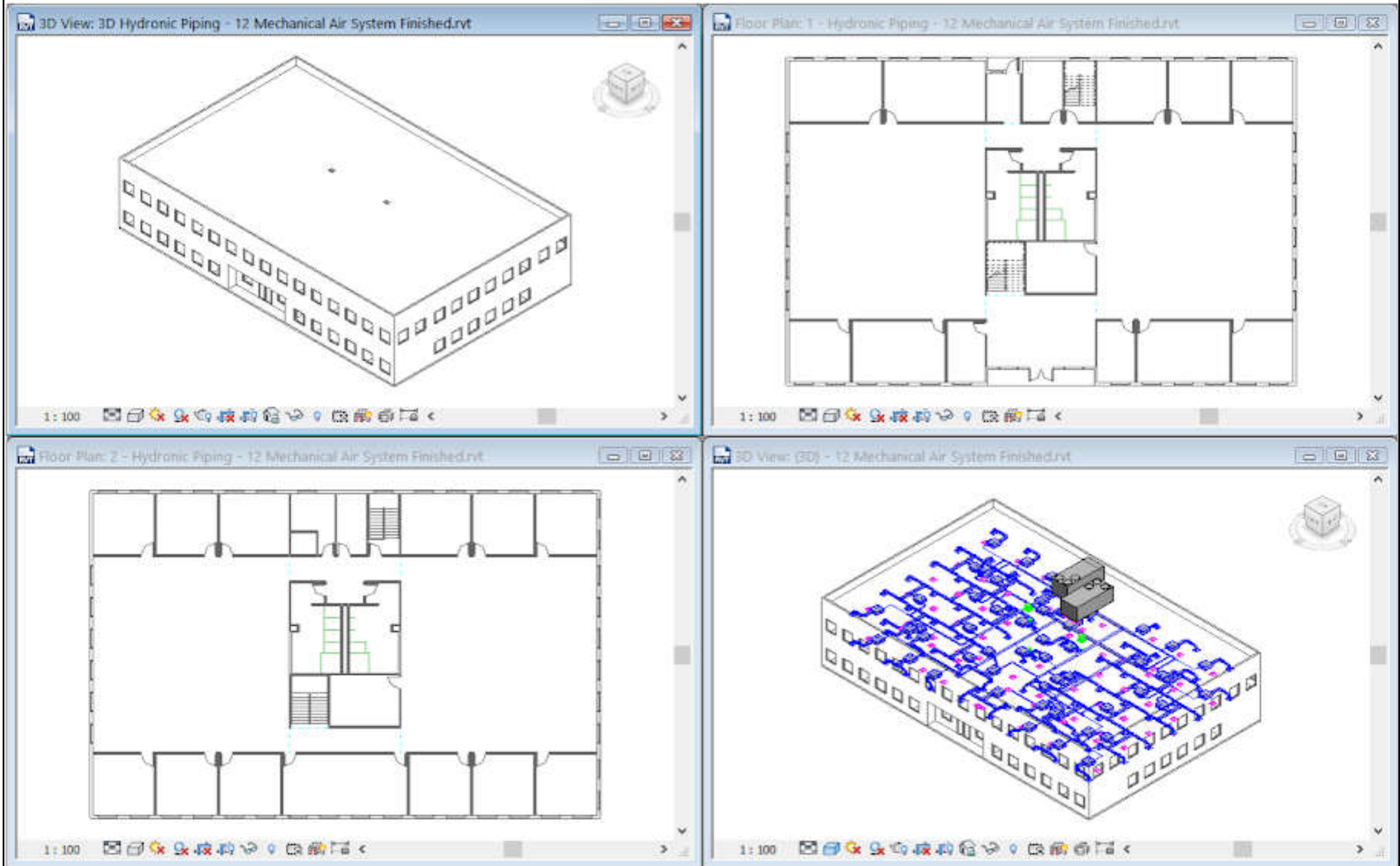

# 3D view of hydronic piping systems

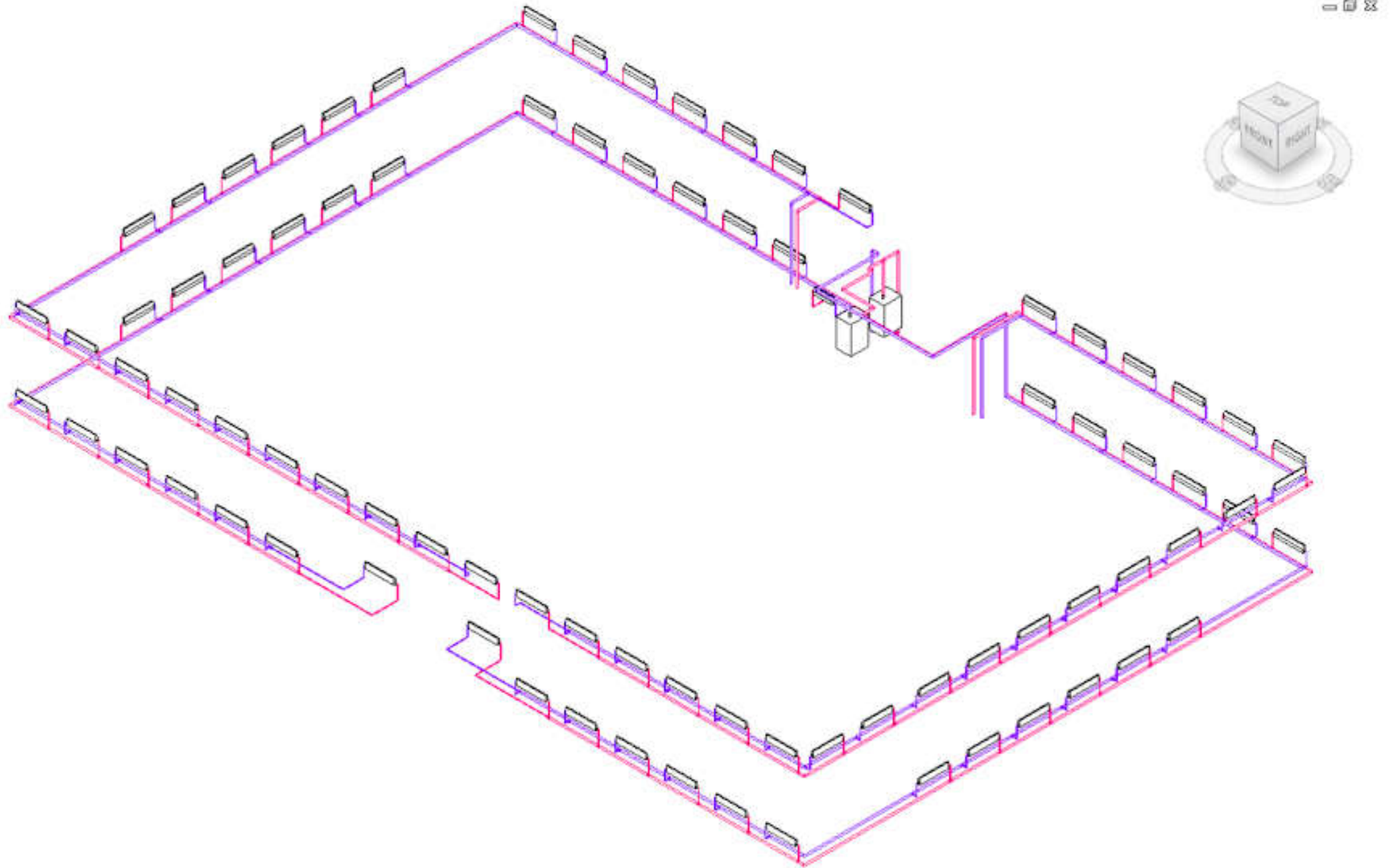

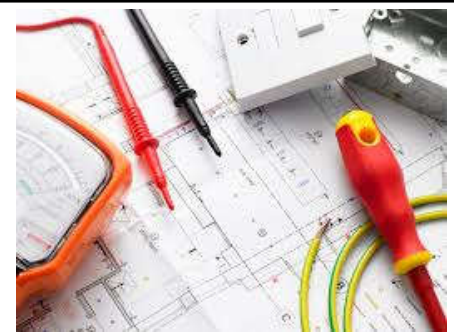







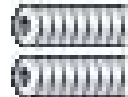

# Electrical systems

- Use Revit MEP to create **electrical systems (circuits)** to place devices, lighting fixtures, and electrical equipment in a project\*
  - Work with electrical components
  - Create & edit circuits
  - Create & edit switch systems
  - Electrical sizing & calculations
- Need to understand electrical services design requirements & process

# Typical components of electrical systems

- Systems tab > Electrical panel >

-  (Wire)
-  (Cable Tray)
-  (Conduit)
-  (Parallel Conduits)
-  (Cable Tray Fitting)
-  (Conduit Fitting)
-  (Electrical Equipment)
-  (Device)
-  (Lighting Fixture)

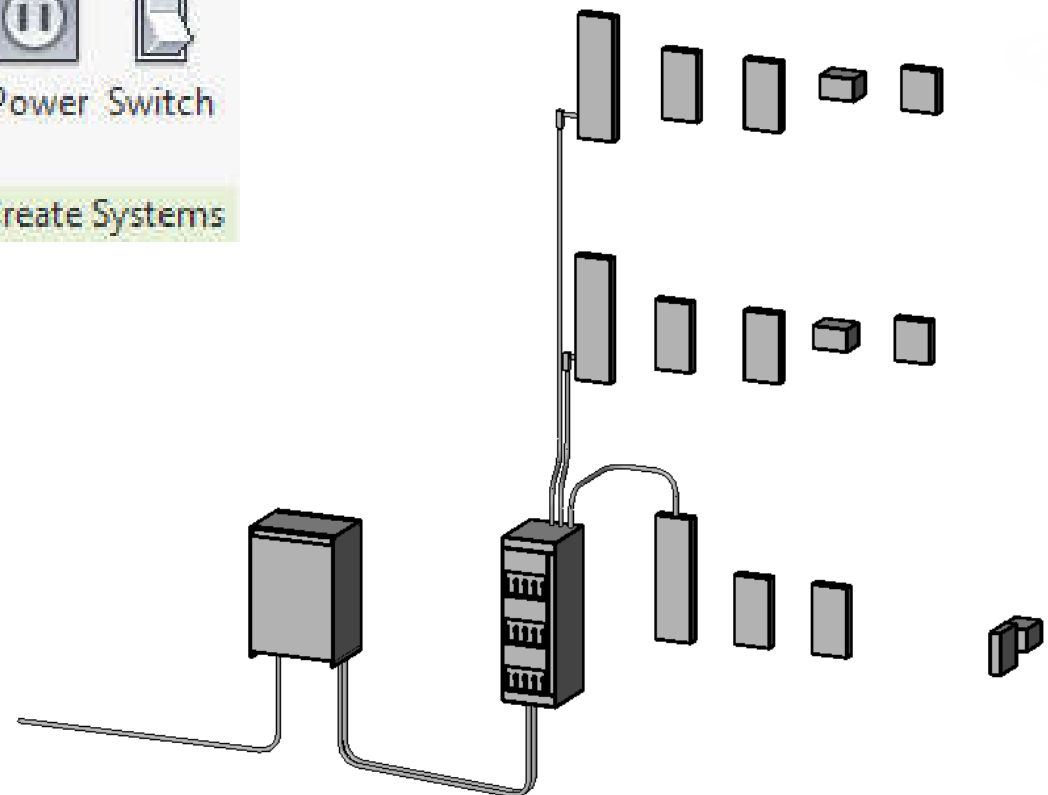
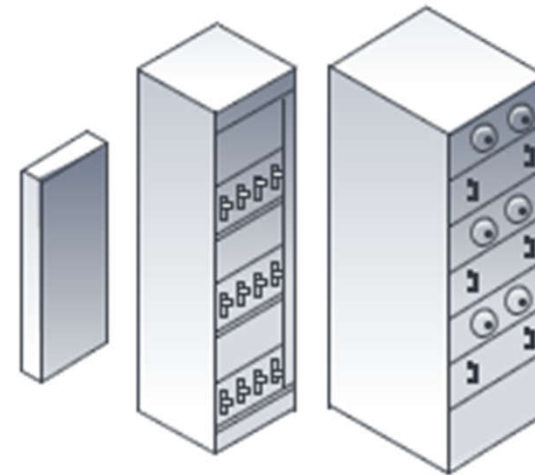

# Electrical systems



- Electrical loads
  - Lighting and power for a space
  - These loads affect the cooling & heating loads analysis according to the lighting & power schedules
- Electrical family parameters\*
  - Specify the parameter type & properties
  - Customize electrical families
  - Facilitate productivity & improve accuracy

# Electrical system design in Revit MEP

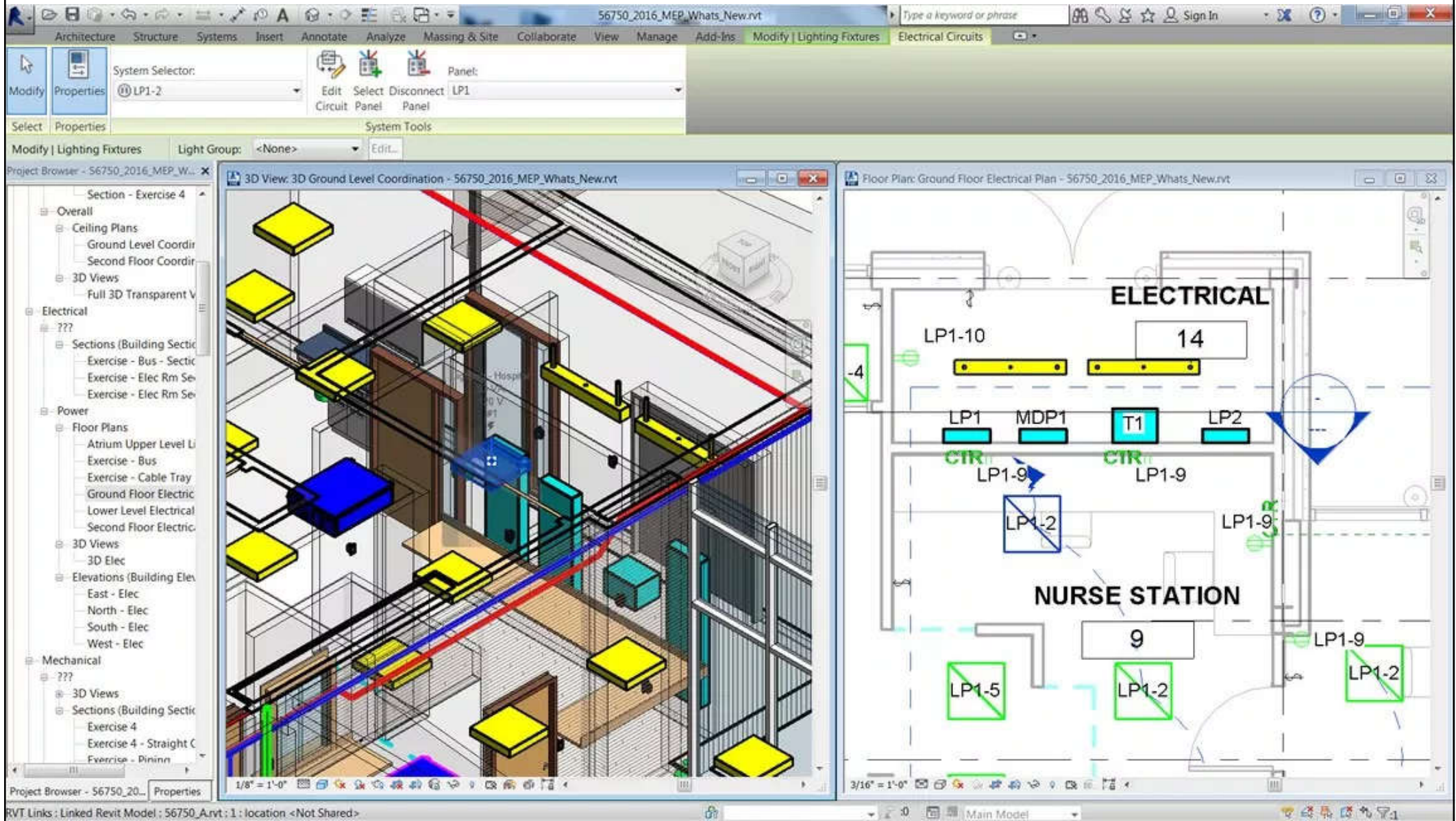

# Create circuit and wiring

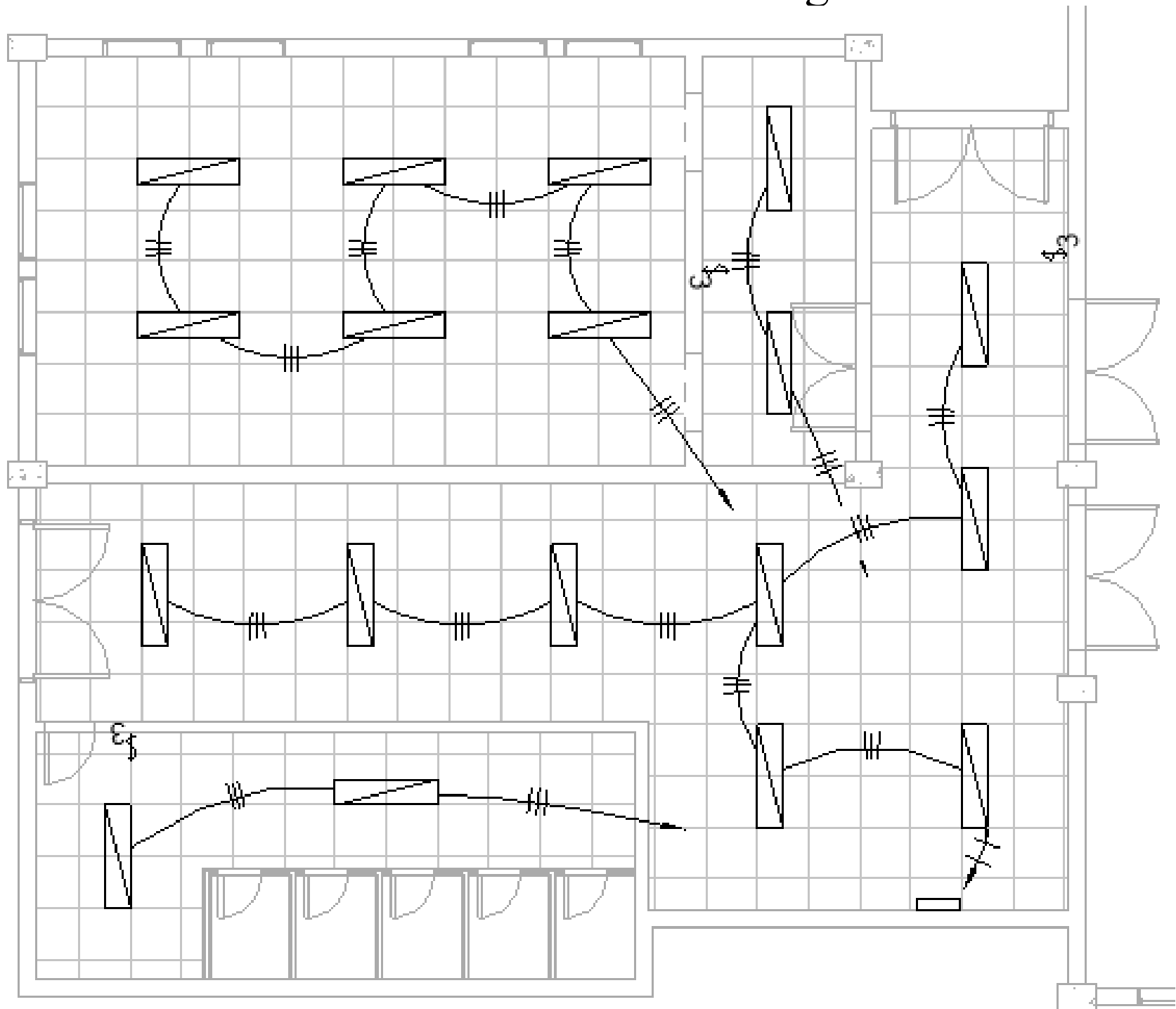

# An example of electrical circuit schedule

Electrical Circuit Schedule							
Circuit Number	Load Name	Voltage	Length	Voltage Drop	Breaker Size	Apparent Current	Wire Size
<b>HA</b>							
1	Lighting Room 103, 104, 105	277 V	288' - 5 3/4"	5 V	20 A	10 A	1-#8, 1-#8, 1-#8
2	Exterior Lighting - Entrance	277 V	311' - 3 5/32"	2 V	20 A	2 A	1-#12, 1-#12, 1-#12
3	Site Lighting	277 V	78' - 3 1/2"	0 V	20 A	1 A	1-#12, 1-#12, 1-#12
4	Site Lighting	277 V	57' - 8 5/8"	0 V	20 A	0 A	1-#12, 1-#12, 1-#12
5	SPARE	277 V	0' - 0"	0 V	20 A	0 A	1-#12, 1-#12, 1-#12
6	SPARE	277 V	0' - 0"	0 V	20 A	0 A	1-#12, 1-#12, 1-#12
7,9,11	ELEVATOR	480 V	28' - 11 1/16"	1 V	50 A	27 A	3-#6, 1-#6, 1-#10
8,10,12	TA	480 V	7' - 0 17/32"	0 V	50 A	14 A	3-#6, 1-#6, 1-#10
<b>HB</b>							
1	Lighting STAIR 3 S3	277 V	82' - 2 23/32"	0 V	20 A	1 A	1-#12, 1-#12, 1-#12
2	Lighting STAGE 115	277 V	103' - 1 7/32"	1 V	20 A	1 A	1-#12, 1-#12, 1-#12
3	Lighting AUDITORIUM/THEAT	277 V	232' - 9 3/16"	4 V	20 A	5 A	1-#12, 1-#12, 1-#12
4	Exterior Lighting	277 V	76' - 6 25/32"	0 V	20 A	0 A	1-#12, 1-#12, 1-#12
5	Lighting Room 102, 100, S3, 1	277 V	279' - 3 3/16"	5 V	20 A	5 A	1-#12, 1-#12, 1-#12
6	Site Lighting	277 V	101' - 3 27/32"	0 V	20 A	0 A	1-#12, 1-#12, 1-#12
7	Lighting Room 112, 113, 102,	277 V	131' - 6 7/16"	1 V	20 A	2 A	1-#12, 1-#12, 1-#12
8	Lighting Room 118, 117, 116	277 V	57' - 7 17/32"	0 V	20 A	2 A	1-#12, 1-#12, 1-#12
15	SPARE	277 V	0' - 0"	0 V	20 A	0 A	
17	SPARE	277 V	0' - 0"	0 V	20 A	0 A	
19,21,23	TB	480 V	6' - 6 1/8"	0 V	50 A	11 A	3-#6, 1-#6, 1-#10
20	SPARE	277 V	0' - 0"	0 V	20 A	0 A	

# Plumbing systems



- They are logical entities that facilitate calculations for flow & sizing of equipment
- They are independent of the piping that is placed in a project to show the routing & connections between plumbing fixtures
- 3 types of plumbing: domestic hot water, domestic cold water & sanitary systems
  - Can also create custom system types, e.g. compressed air system

# Plumbing fixtures & piping to create a sanitary system

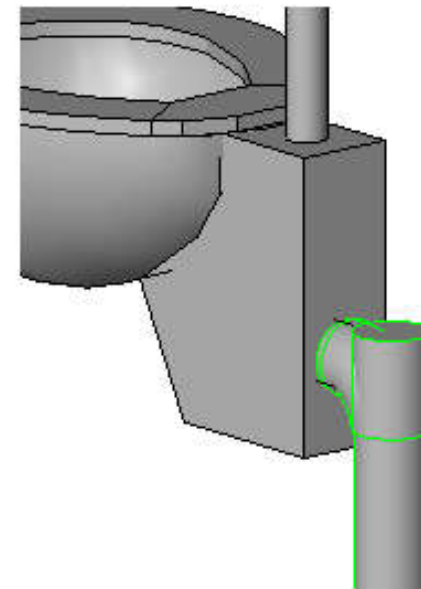
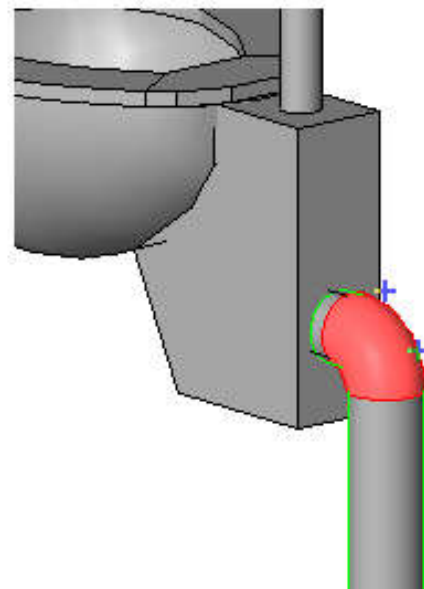
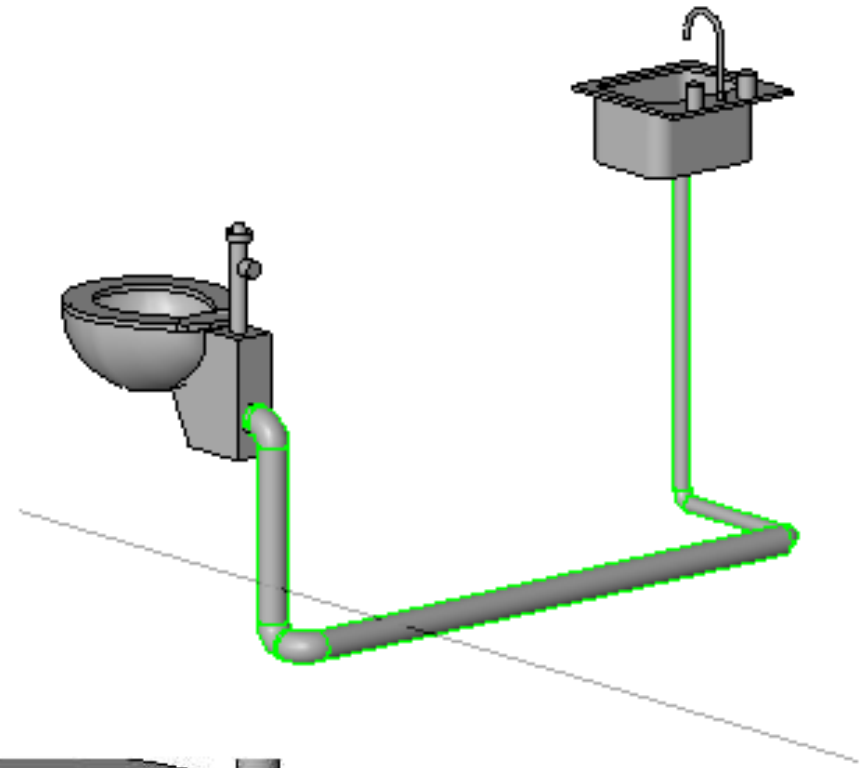
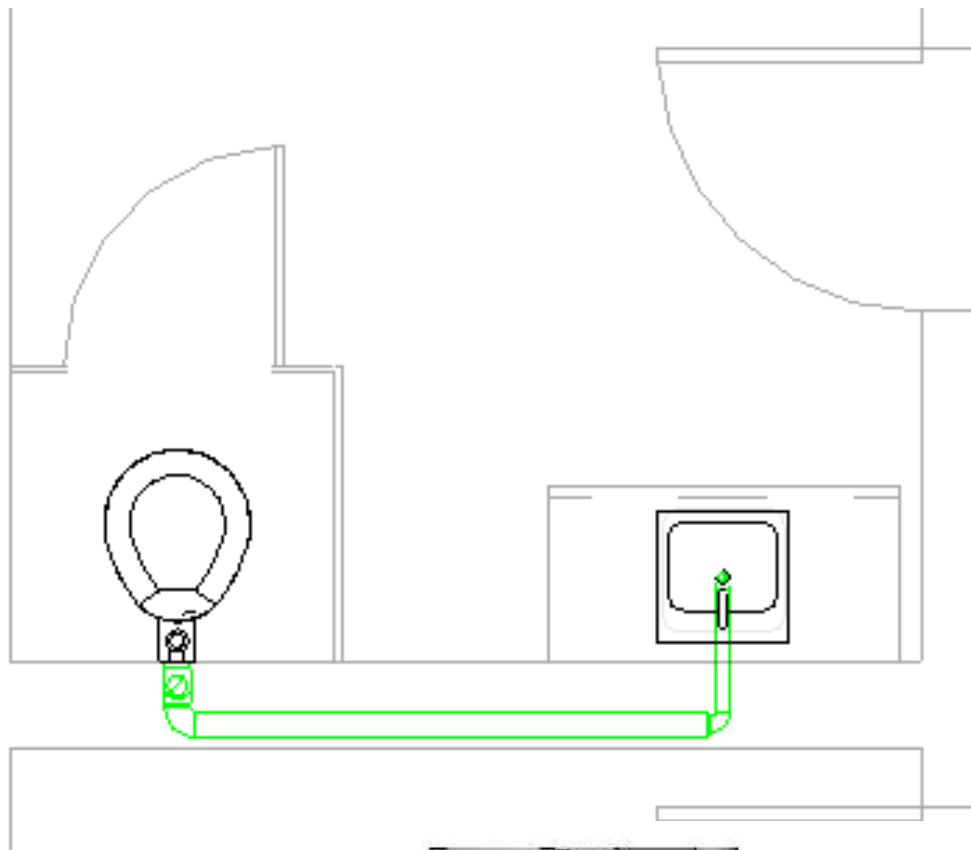

# Plumbing systems



- Pipe sizing & calculation methods
  - Revit automatically calculates specific pipe sizing for the systems using friction and/or velocity sizing methods
  - Computes pressure losses in piping based on the geometry and roughness of piping, fluid density, and fluid dynamic viscosity
  - Uses the Excess Head (K) method to compute the head loss through a fitting

$$h_L = K \frac{V^2}{2g}$$

# Plumbing systems



- With BIM, a plumbing designer has to become a “virtual pipe installer”
- Configuring the plumbing views is important
  - Global settings and view-specific settings
    - Need to adjust several settings so the pipes are properly displayed
  - Defining systems visibility through filters
    - Define colour, line patterns & line weights
    - Display 3D views, using workset visibility to turn off unnecessary ones

# Visibility/Graphic overrides for plumbing systems

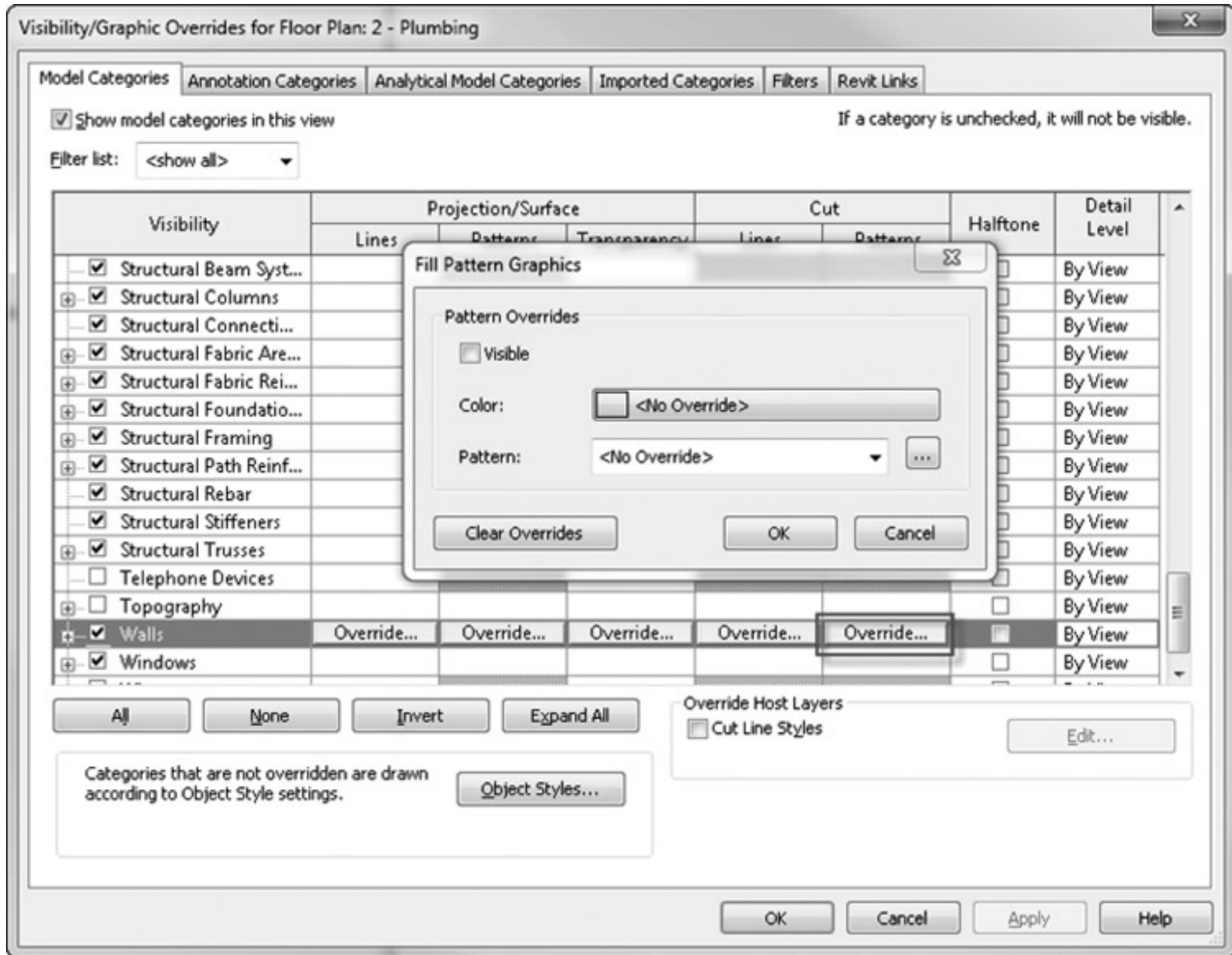



# Plumbing systems



- Working with architectural linked-in plumbing models
  - Coordinated with any architectural plan changes
  - Two methods to create custom pipe assemblies:
    - Pipe assembly created with sweeps
    - Assemble nested families
      - Can allow for better quantity take-offs for all the fittings, create more-accurate dimensional information when supplied by manufacturers, and be easier for the designer to create
      - The downside is that it produces a larger family file

# Two methods to create custom pipe assemblies

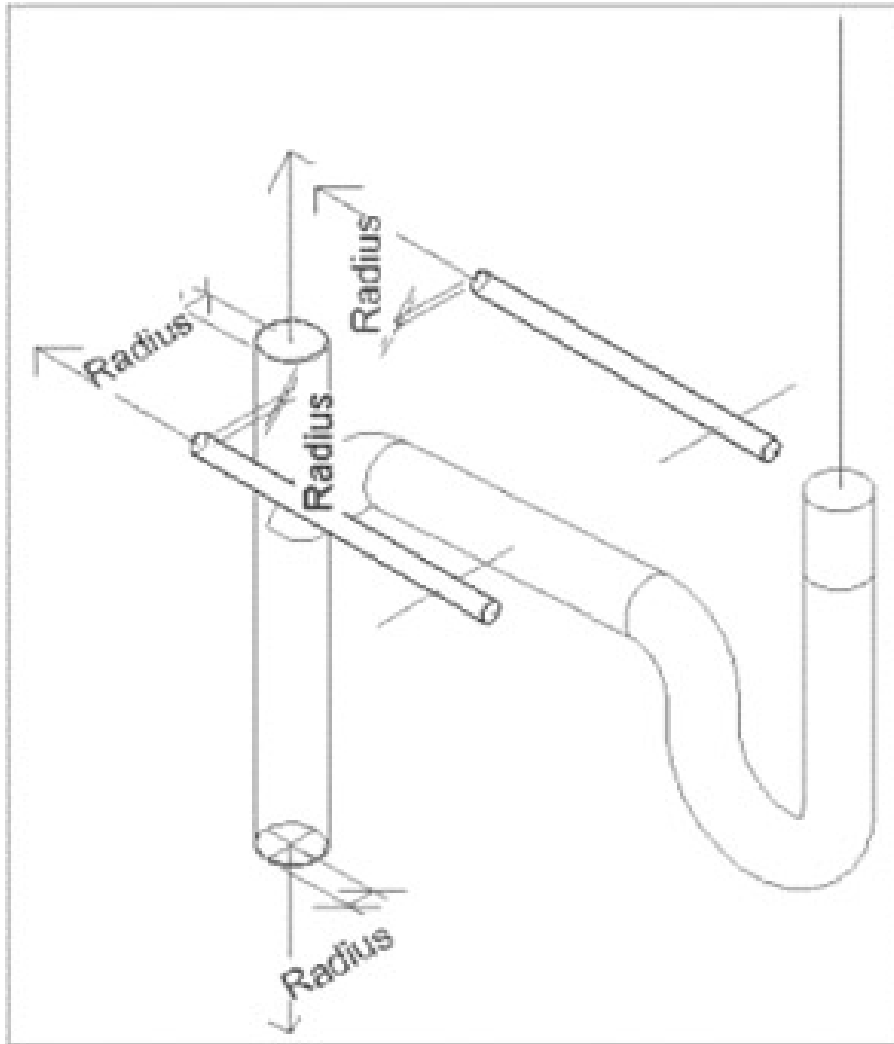

A pipe assembly created with sweeps

Nested  
pipe  
assembly

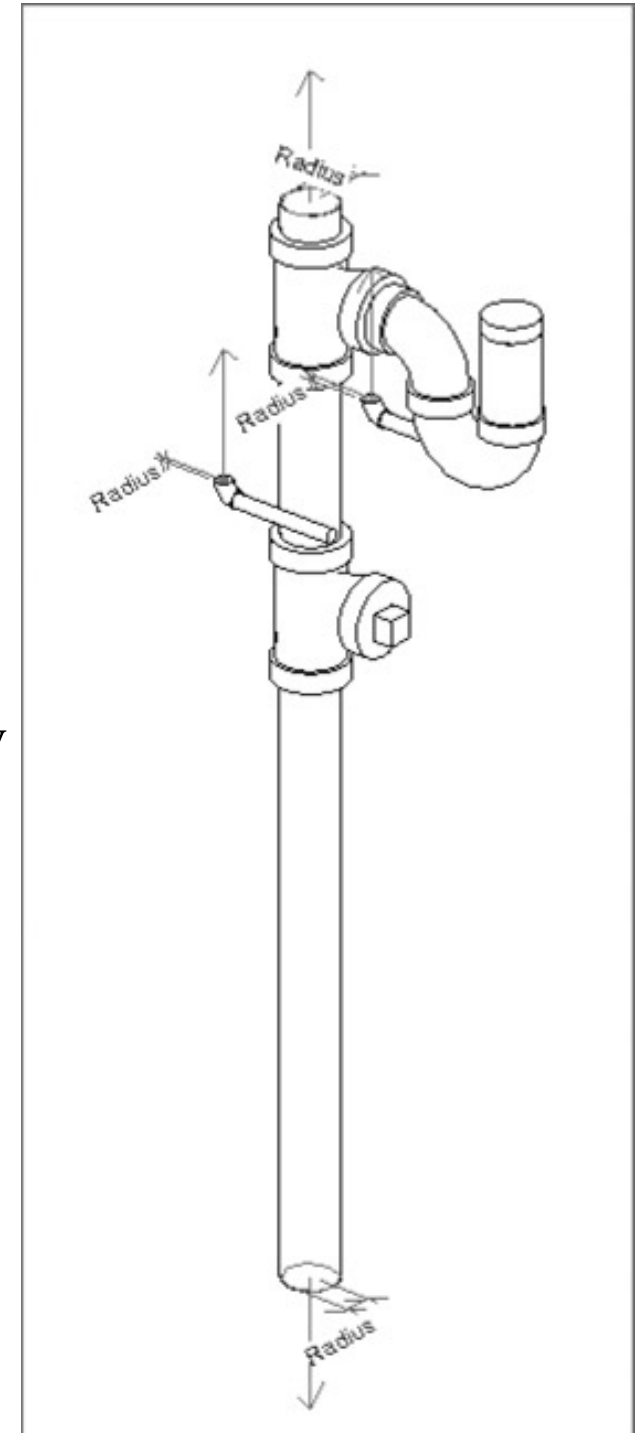

# Copying/Monitoring plumbing fixtures

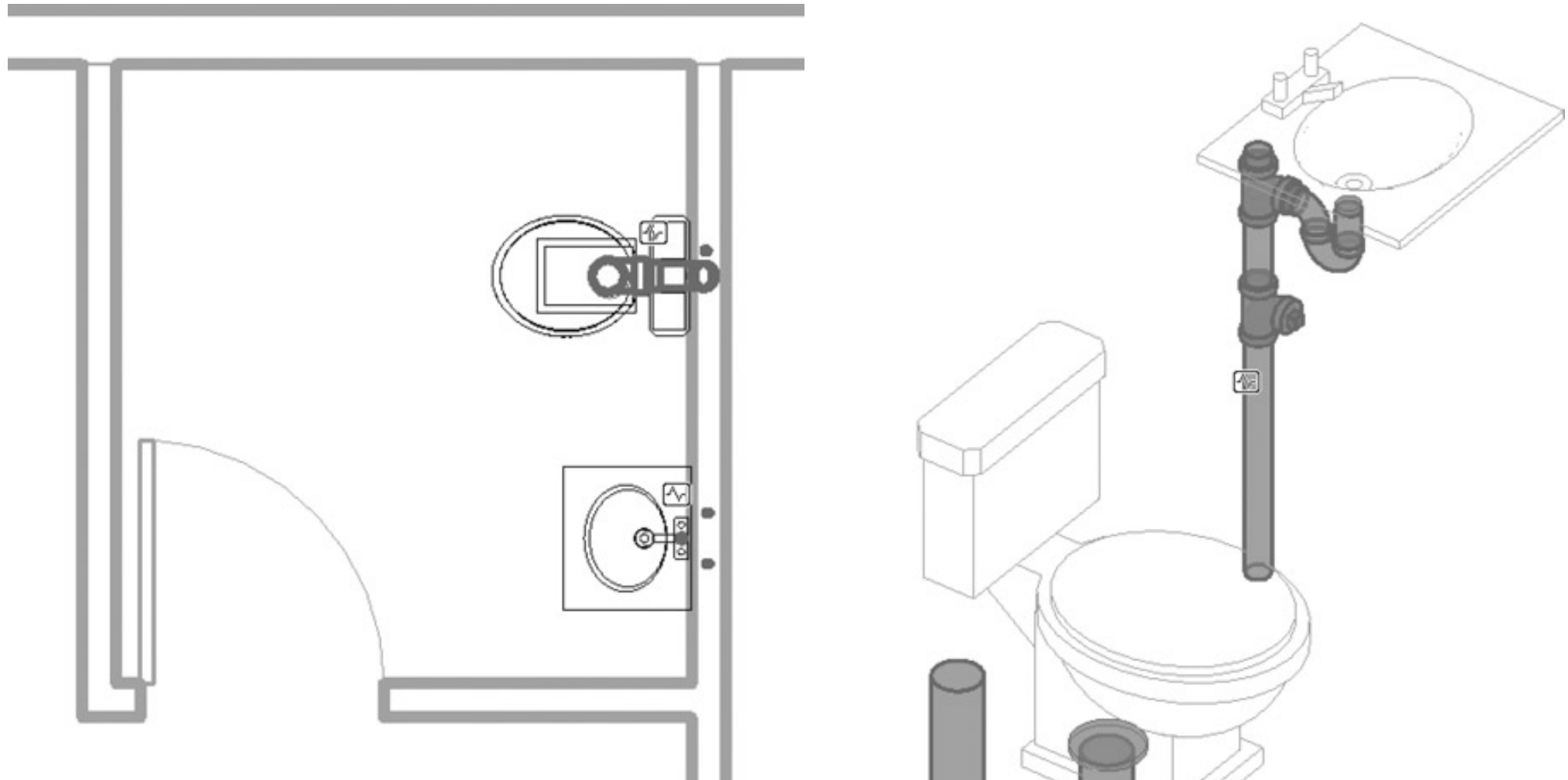

Collaborate with the architect:

When the architect moves a plumbing fixture, you will receive a warning that you need to coordinate your view

# Plumbing systems



- Choosing pipe settings & pipe routing options
  - Apply the appropriate pipe material & pipe fittings
    - To get the invert elevation for sloping systems
  - Model sloping pipe:
    - Use either auto-route or manual routing feature
    - Locate the sanitary point of connection (POC) outside the building (draw from the main first)
  - Annotate invert elevation & the slope
    - Apply parametric elevation and slope annotations

# Sanitary layout with sloped piping

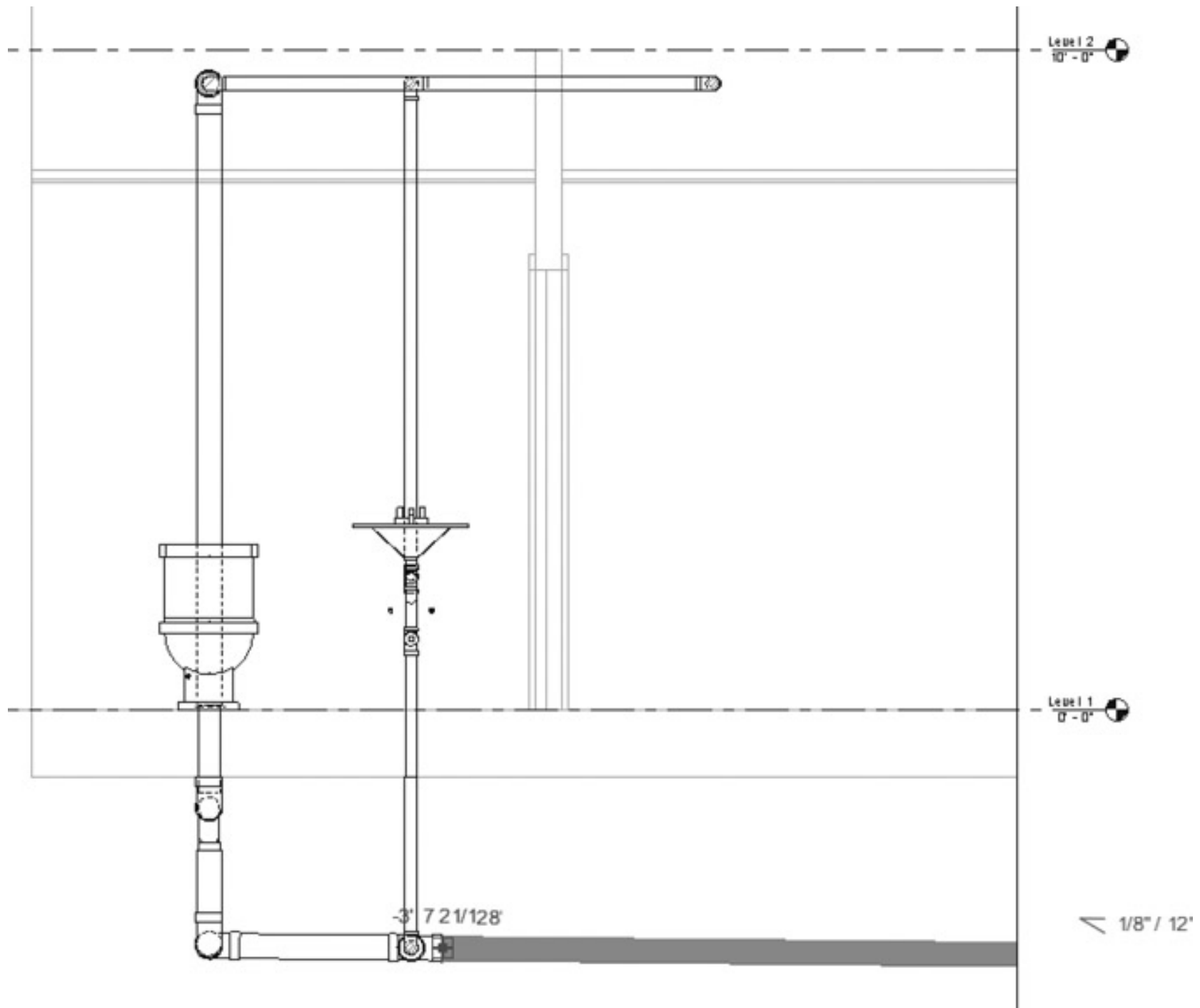

# Plumbing systems



- Using pipe fittings
  - Revit fitting families:
    - End cap
    - Tee, tap, wye, or cross
    - Transitions, couplings, or unions
    - Flange
  - Pipe fitting controls
  - Placing valves & pipe accessories

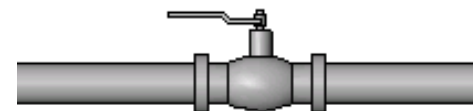
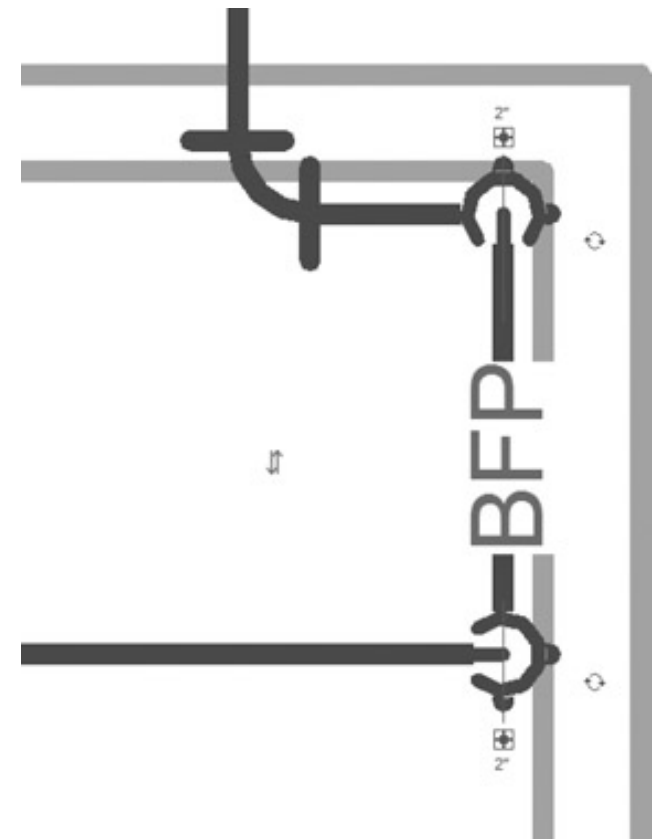

# Plumbing systems



- Video: Revit MEP Lesson 16: How To Create a Sanitary Plumbing System (13:16)
  - <https://youtu.be/ASHODy2NpyA>
  - Demonstrate how to create a sanitary system on Revit MEP
- More video tutorials on plumbing:
  - REVIT MEP EXAM REVIEW\_MODELING\_HOW TO DO PLUMBING IN REVIT 2017 (26:25) [https://youtu.be/ESHY\\_ojZYlw](https://youtu.be/ESHY_ojZYlw)
  - REVIT MEP EXAM REVIEW\_MODELING\_HOW TO DO PLUMBING PART 2 IN REVIT 2017 (23:45) <https://youtu.be/N1eICAUmAXQ>

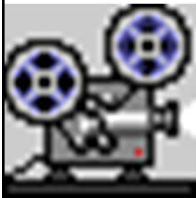

# Plumbing systems



- Revit MEP tutorial for plumbing:
  - <https://www.cad-notes.com/tag/revit-mep-basic/page/2/>
  - Placing the Sanitary Components
  - Creating Water Supply Route
  - Connecting Plumbing Fixture to Pipe Route
  - Creating Drain Route
  - Modifying Route

# Revit MEP tutorial: Placing the Sanitary Components

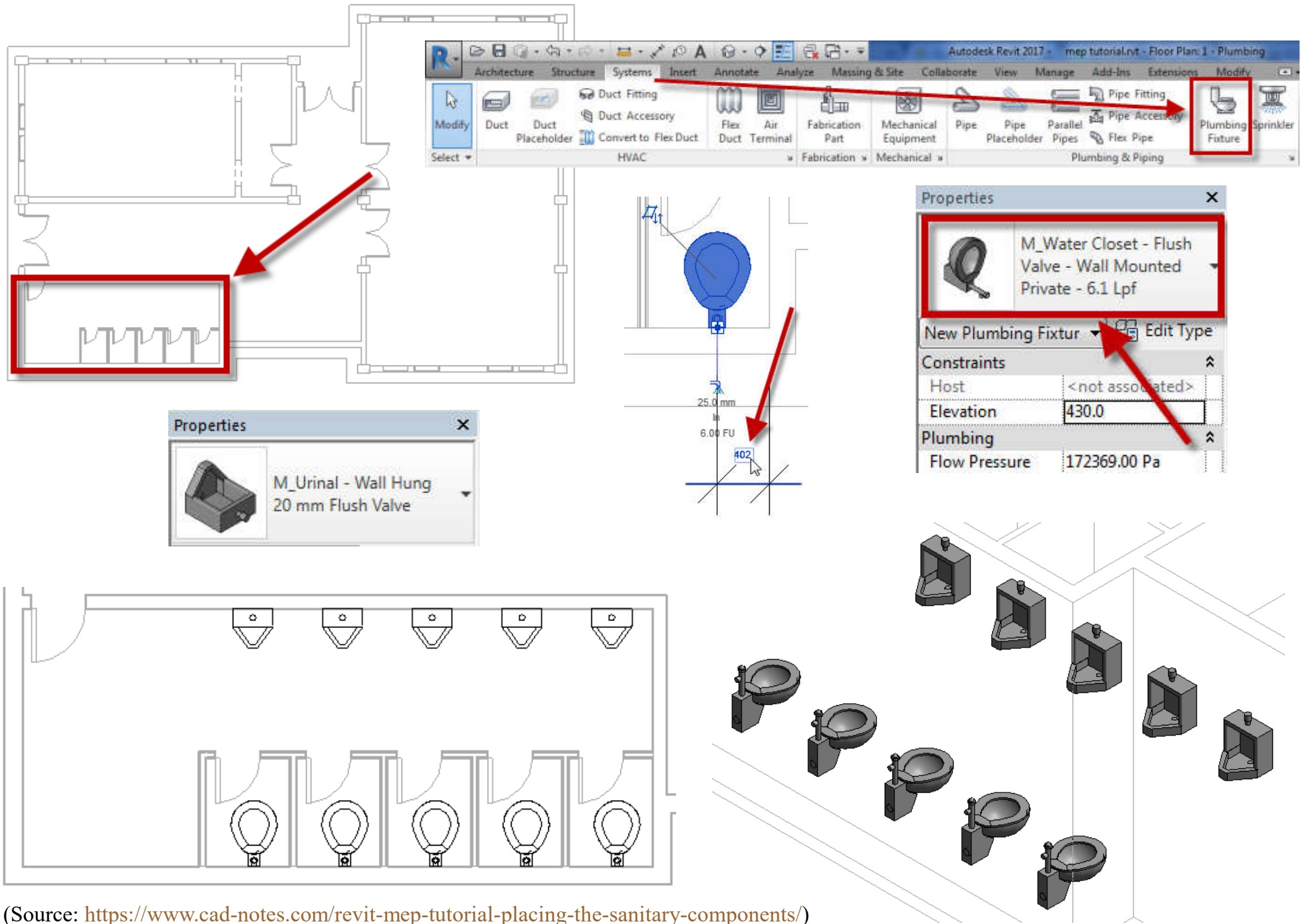

# Revit MEP tutorial: Creating Water Supply Route

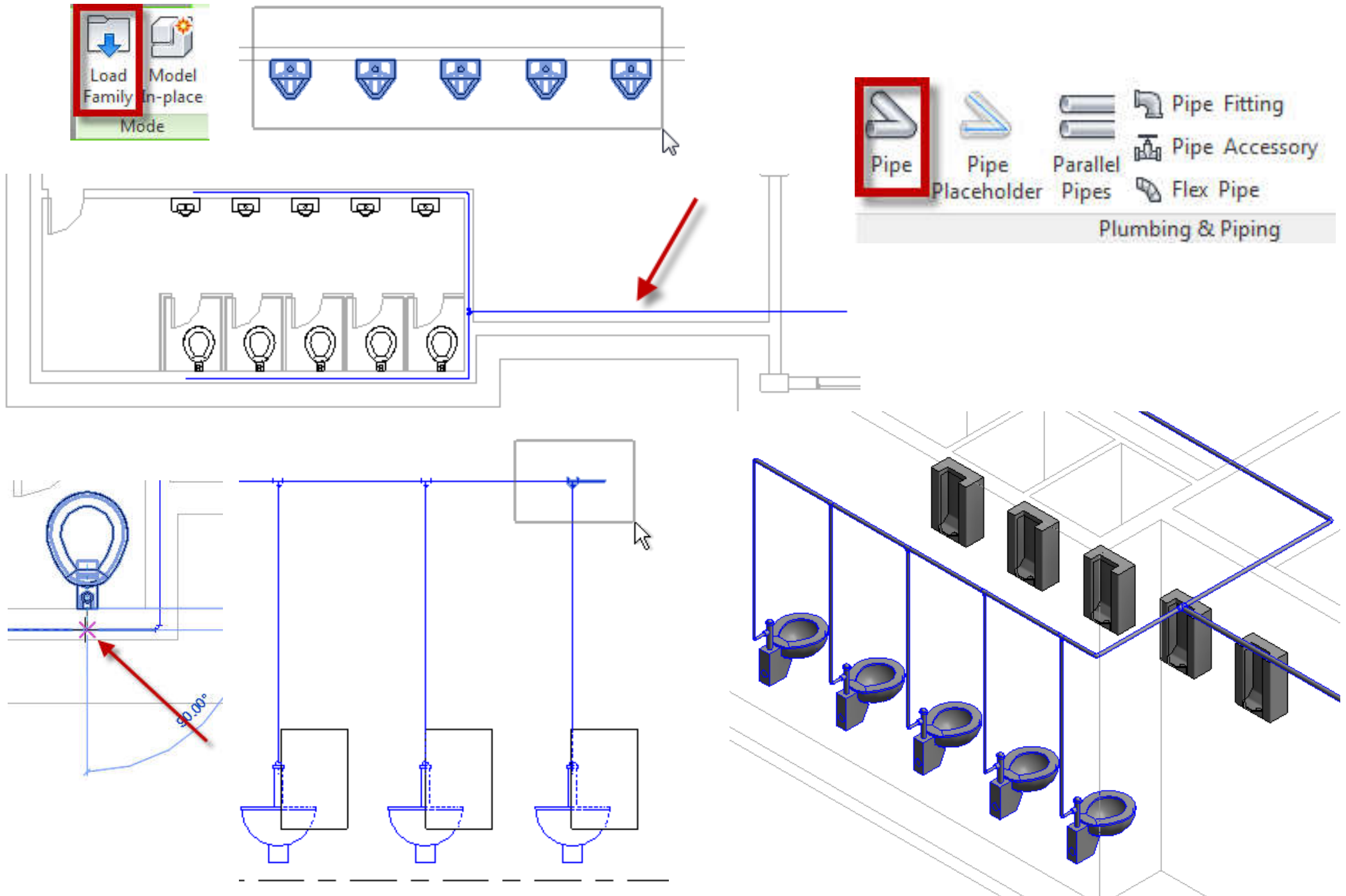

# Revit MEP tutorial: Connecting Plumbing Fixture to Pipe Route

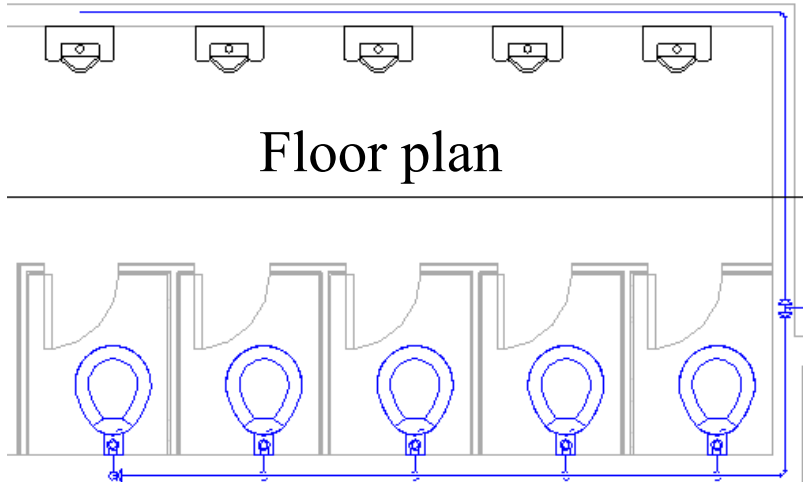
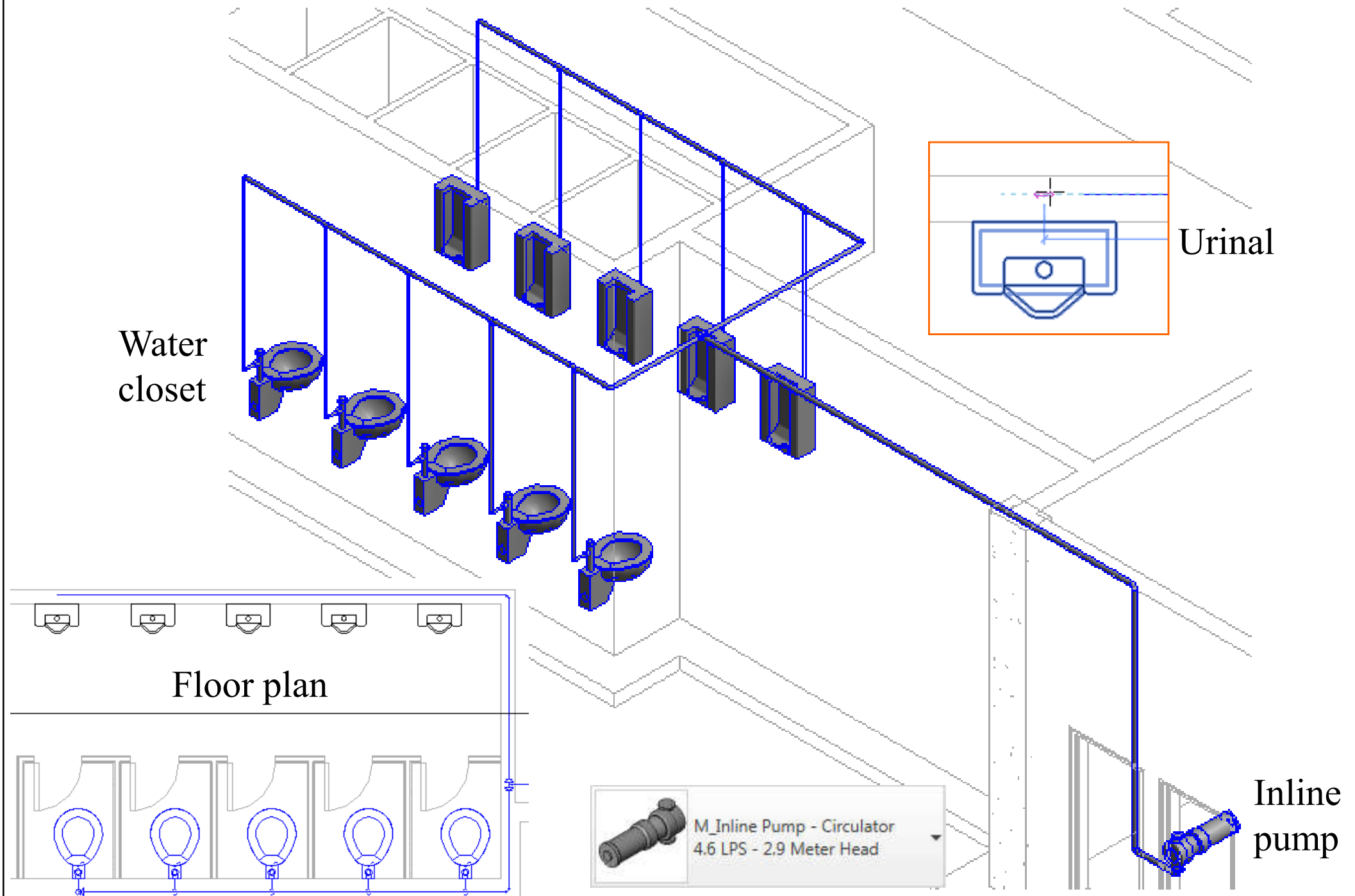

# Revit MEP tutorial: Creating Drain Route

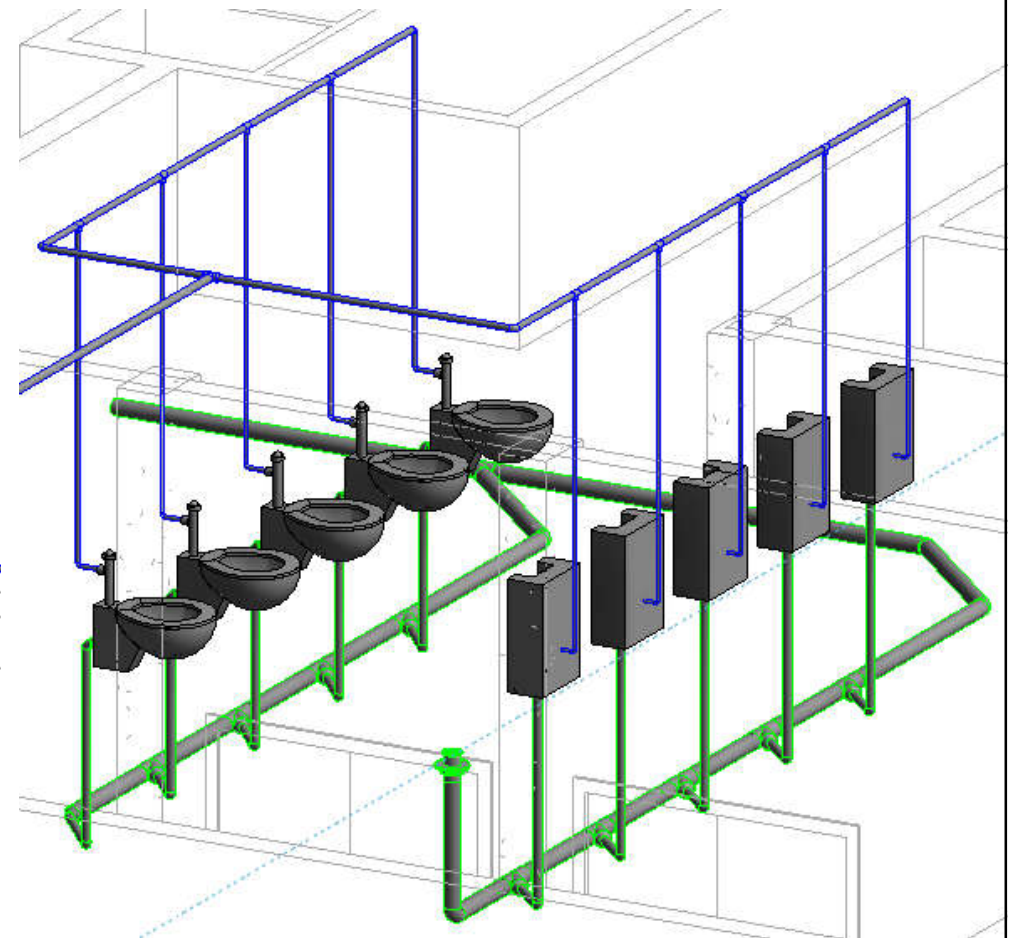
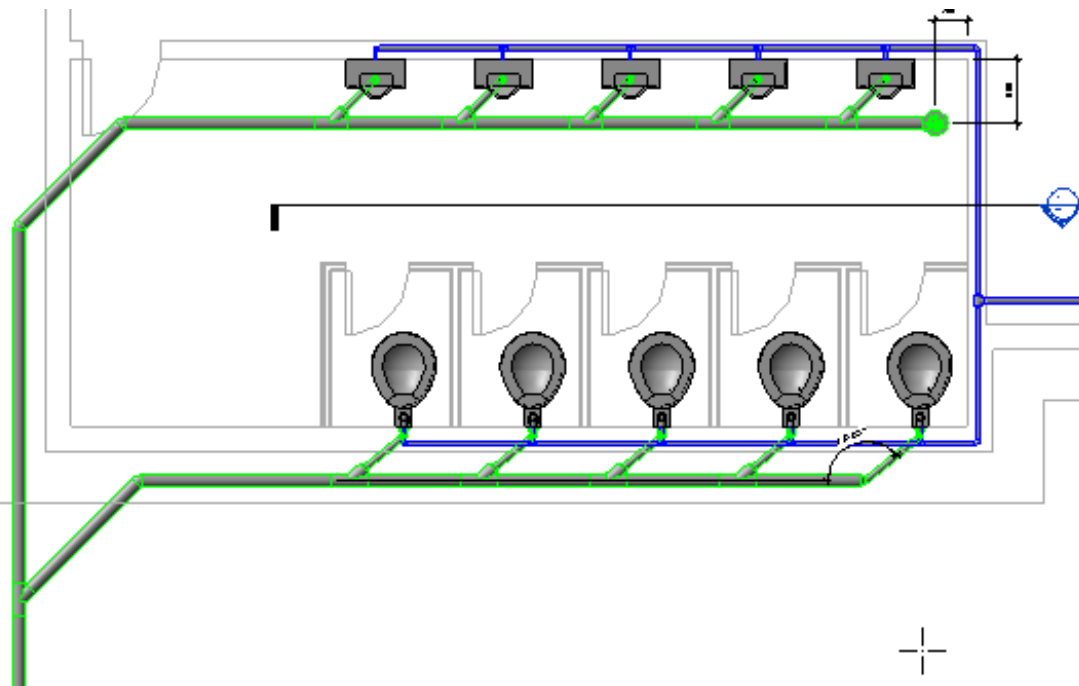
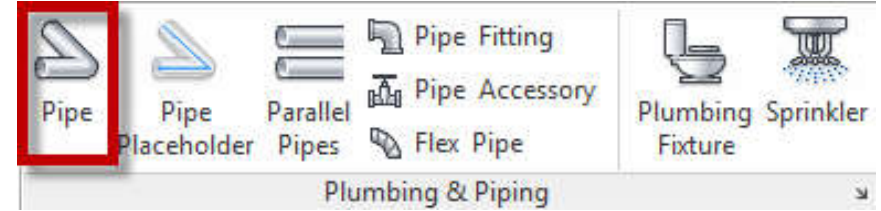
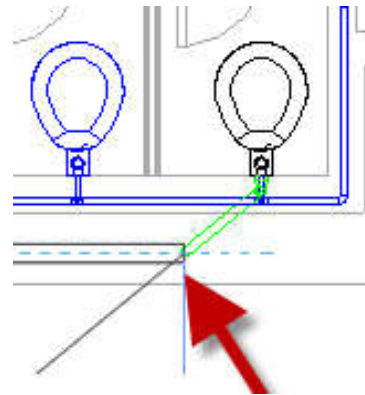
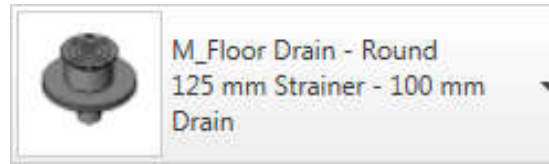
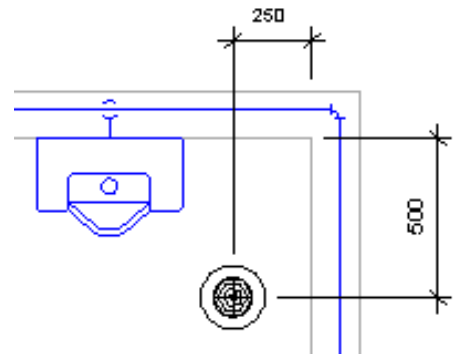

# Revit MEP tutorial: Modifying Route

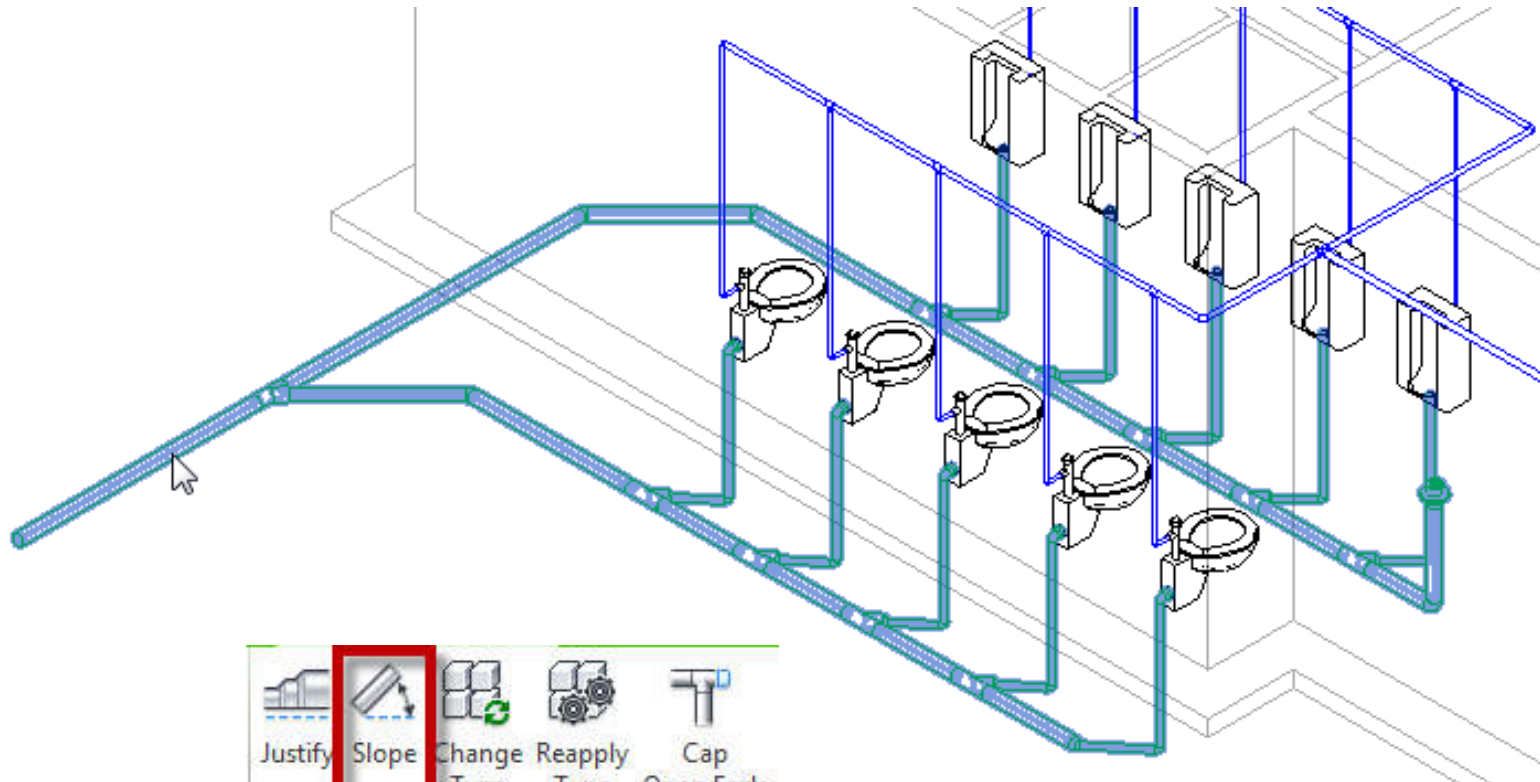

Change the pipe size from urinal

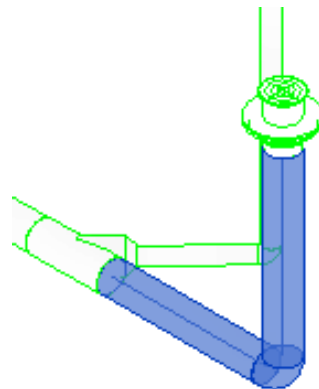
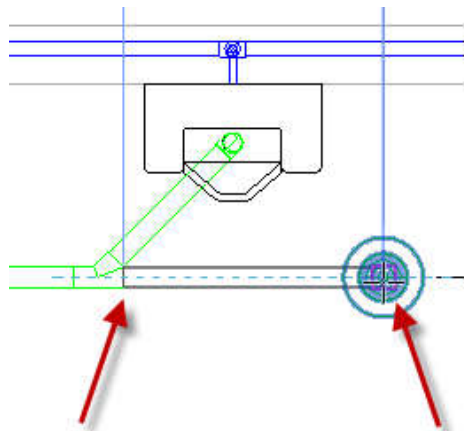
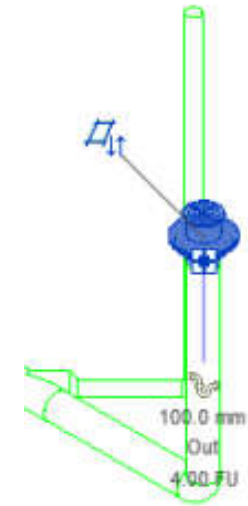

Change the pipe slope

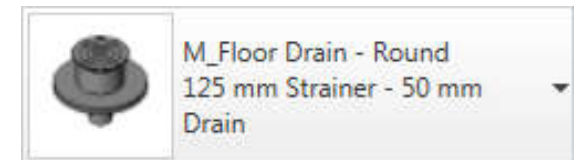

# Fire sprinkler design drawings from a proprietary program

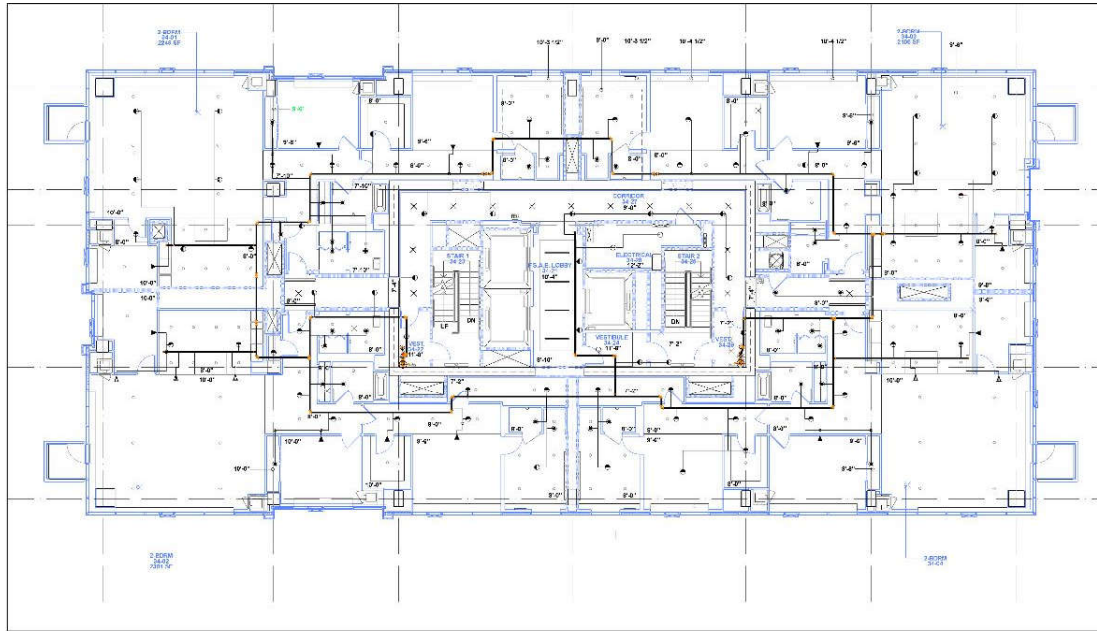
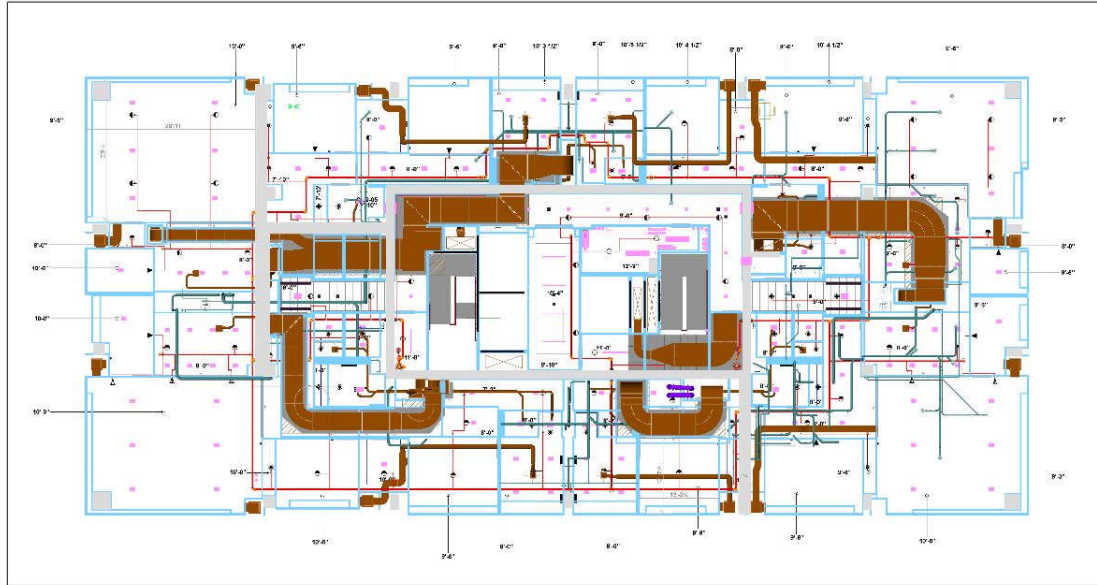

1 FIRE SPRINKLER PLAN  
[sheet:nomtag] 1/11/07  
0" = 2' 4"

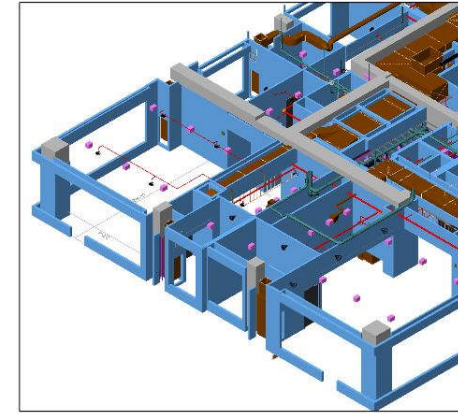

ISOMETRIC A



ISOMETRIC B



ISOMETRIC C



QUALITY DESIGN, LLC  
1000 W. PARKWAY, SUITE 100  
LITTLE ROCK, AR 72202  
501.225.1111

PROJECT: SL  
DATE: 01/25/10  
NO: 10-0764

CLIENT: [redacted]  
INSTALLATION CONTRACTOR:

XX FIRE PROTECTION  
281 SHANPAC AVE  
HENDERSON, KY 40130  
STATE LICENCE #85034-C-1-A STATE FIRE MARSHAL #03128

NO.	DESCRIPTION	QUANTITY	UNIT	DATE	BY	CHKD.
1	SPRINKLER HEADS	10	EA	01/25/10	[redacted]	[redacted]
2	SPRINKLER RISERS	10	EA	01/25/10	[redacted]	[redacted]
3	SPRINKLER VALVES	10	EA	01/25/10	[redacted]	[redacted]
4	SPRINKLER PIPING	10	EA	01/25/10	[redacted]	[redacted]
5	SPRINKLER PIPING	10	EA	01/25/10	[redacted]	[redacted]
6	SPRINKLER PIPING	10	EA	01/25/10	[redacted]	[redacted]
7	SPRINKLER PIPING	10	EA	01/25/10	[redacted]	[redacted]
8	SPRINKLER PIPING	10	EA	01/25/10	[redacted]	[redacted]
9	SPRINKLER PIPING	10	EA	01/25/10	[redacted]	[redacted]
10	SPRINKLER PIPING	10	EA	01/25/10	[redacted]	[redacted]

REVISIONS:  
1. [redacted]  
2. [redacted]  
3. [redacted]

JOB NAME: [redacted]  
JOB ADDRESS: [redacted]  
JOB CITY: [redacted] JOB STATE: [redacted]  
JOB DESCRIPTION: [redacted]

DATE: [redacted]  
PROJECT: [redacted]

SHEET NO: [redacted]  
SHEET NUMBER: [redacted]

# Nonhosted sprinkler heads

Modify | Sprinklers | Flow: 100 GPM

Properties



Victaulic - V2704- Quick Response  
Spray Upright  
Standard

Sprinklers (1) Edit Type

Constraints

Level	Level 1
Host	Floor : Generic - 12"
Offset	12' 6"

Mechanical

System Classification	Fire Protection Wet
System Type	Fire Protection Wet
System Name	Fire Protection Wet 2
System Abbreviation	
Pressure Drop	

Identity Data

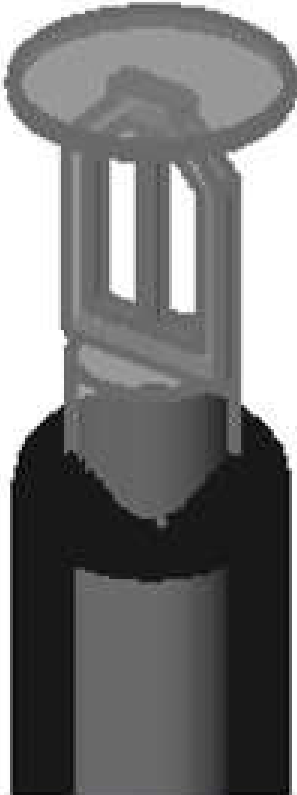

\*Also refer to the details & information from fire equipment manufacturer, such as Victaulic  
<http://www.victaulic.com/>

# An example of fire sprinkler layout

