

GEE5303 Green and Intelligent Building

<http://ibse.hk/GEE5303/>

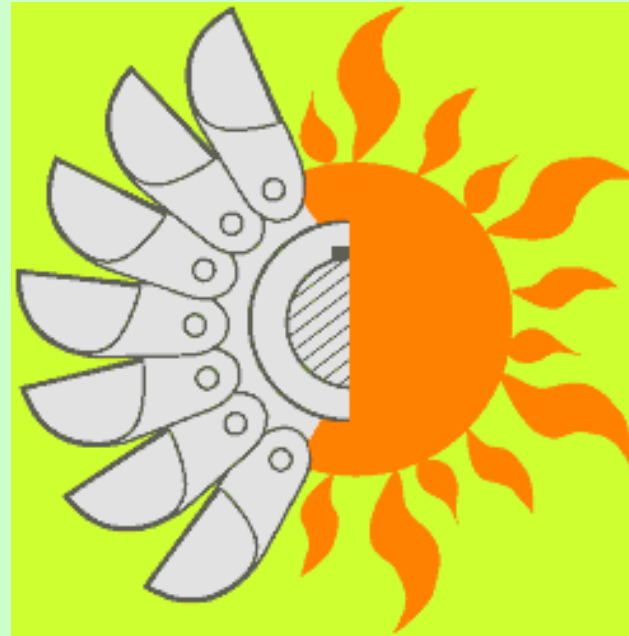

Renewable energy

Thei

Ir. Dr. Sam C. M. Hui

Faculty of Science and Technology

E-mail: cmhui@vtc.edu.hk

Jul 2016

Contents



- Active solar
- Photovoltaics
- Wind energy
- Biomass energy
- Geothermal energy
- Small hydropower
- Ocean energy



Renewable energy



- Definitions

- Energy that occurs naturally and repeatedly on earth and can be harnessed for human benefit
- Such as solar, wind, biomass, energy from waste, geothermal, hydro, wave and tidal, ocean thermal
- Most renewables are derived from the **SUN**
 - Direct use of solar energy for heating or electricity
 - Indirect forms (e.g. wind, waves, running water)





Solar heating for a swimming pool complex in Kwai Chung (313 sq.m solar collectors)

Solar hot water system at Sheung Shui Slaughter House (882 sq.m solar collectors)



Solar thermal systems in Hong Kong

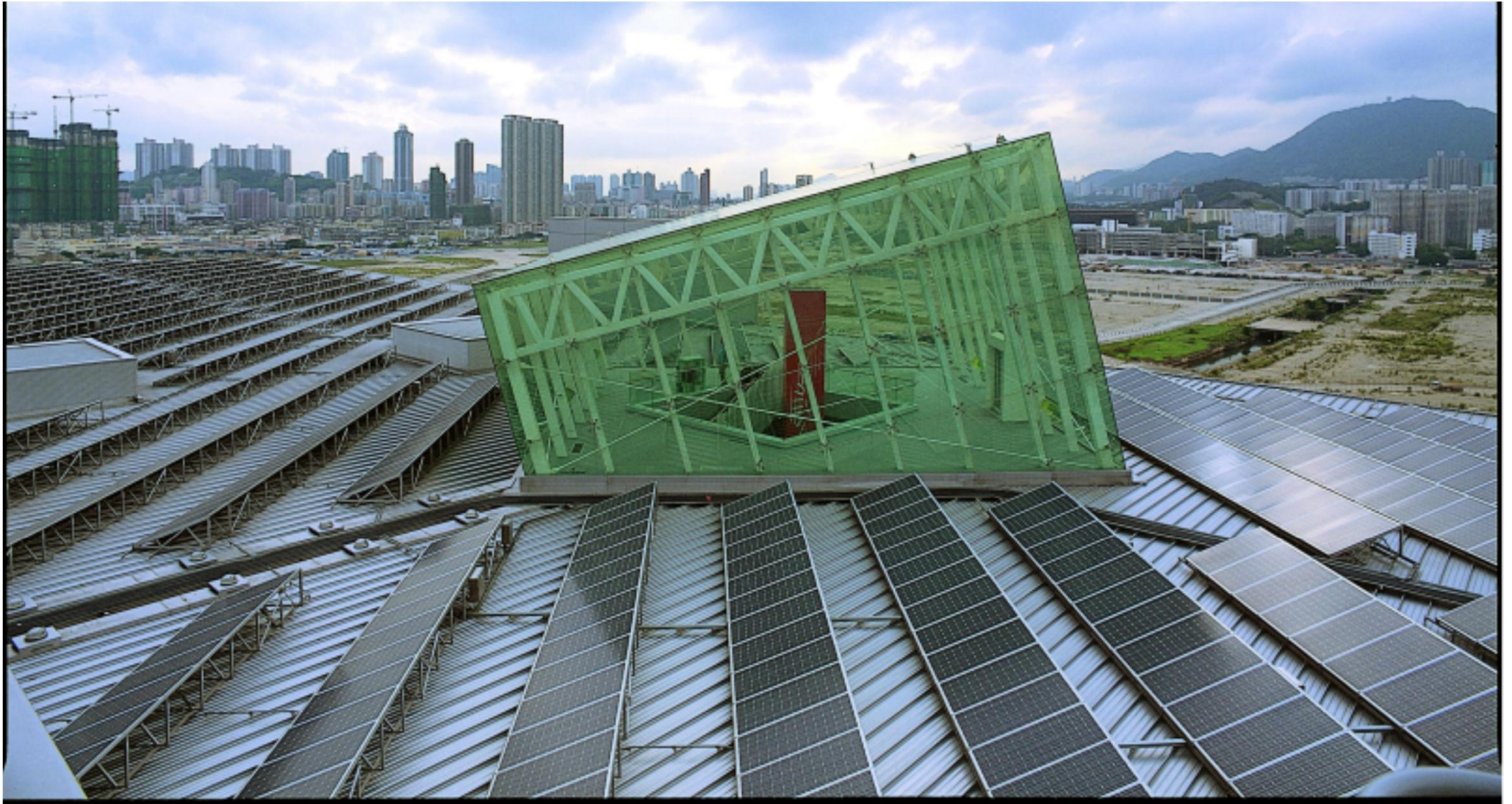

A 350 kW solar photovoltaic (PV) installation installed on the roof of the EMSD Headquarters in Kowloon Bay (2,300 PV modules with a total area of 3,180 sq.m) [Source: EMSD]



Active solar

- Also called ‘**Solar Thermal**’
- Common applications
 - Solar hot water (domestic or non-domestic)
 - Swimming pool heating
 - Space heating or air preheating
 - Solar air-conditioning
 - Using absorption or desiccant cooling system
 - Electricity generation
 - Using steam plant and concentrator

Solar hot water systems

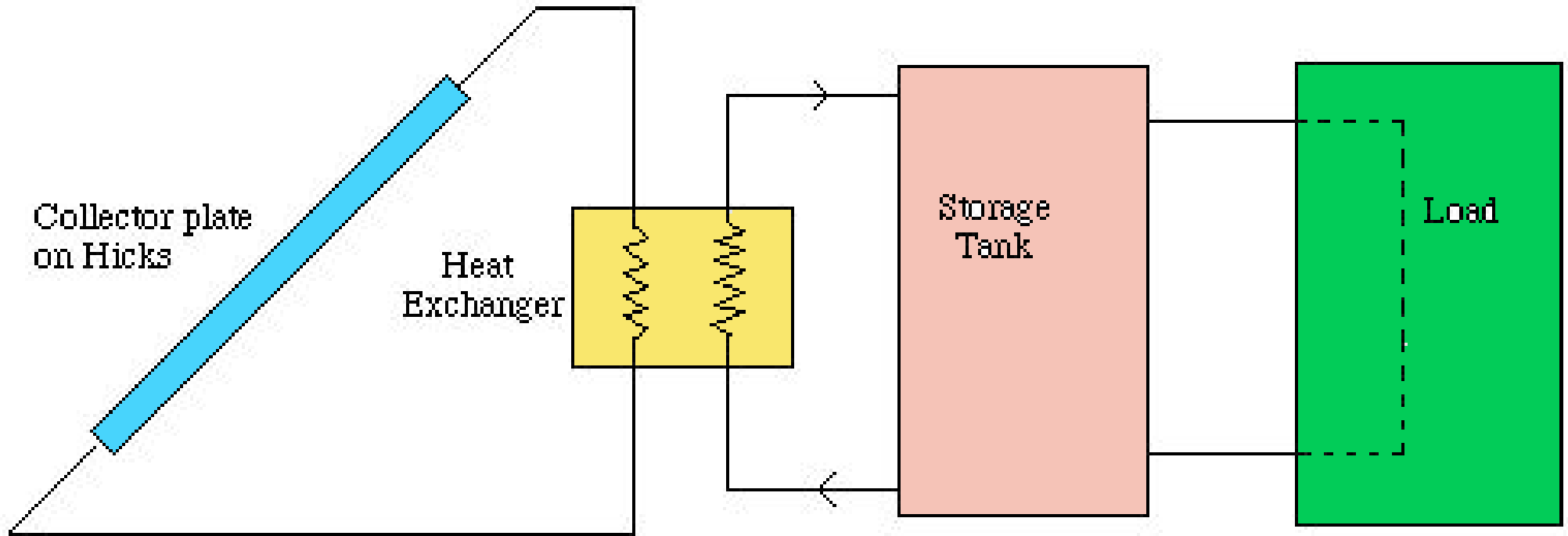

Flat board type



Vacuum glass pipe type

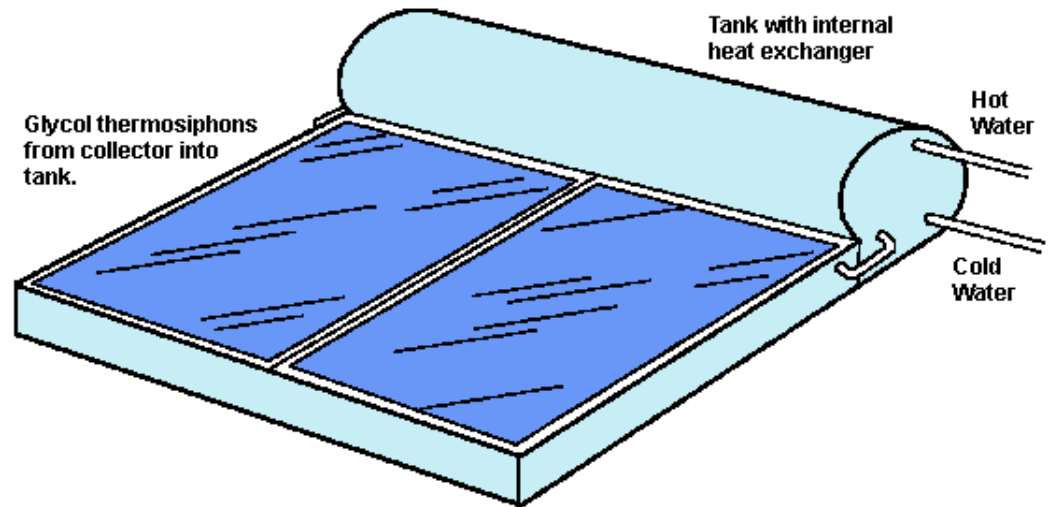

**Simple domestic system
(with integral storage tank)**



Active solar

- Types of solar collectors
 - Flat-plate solar collector
 - Main components: glazing panel, absorber, flow tubes, insulation
 - Evacuated-tube solar collector
 - Water-in-glass type or with heat pipe
 - Concentrating solar collector
 - Smaller receiver area to increase the solar flux
 - Such as parabolic trough, dish concentrator, multifaceted mirror type

Heat transfer processes at a flat-plate solar collector

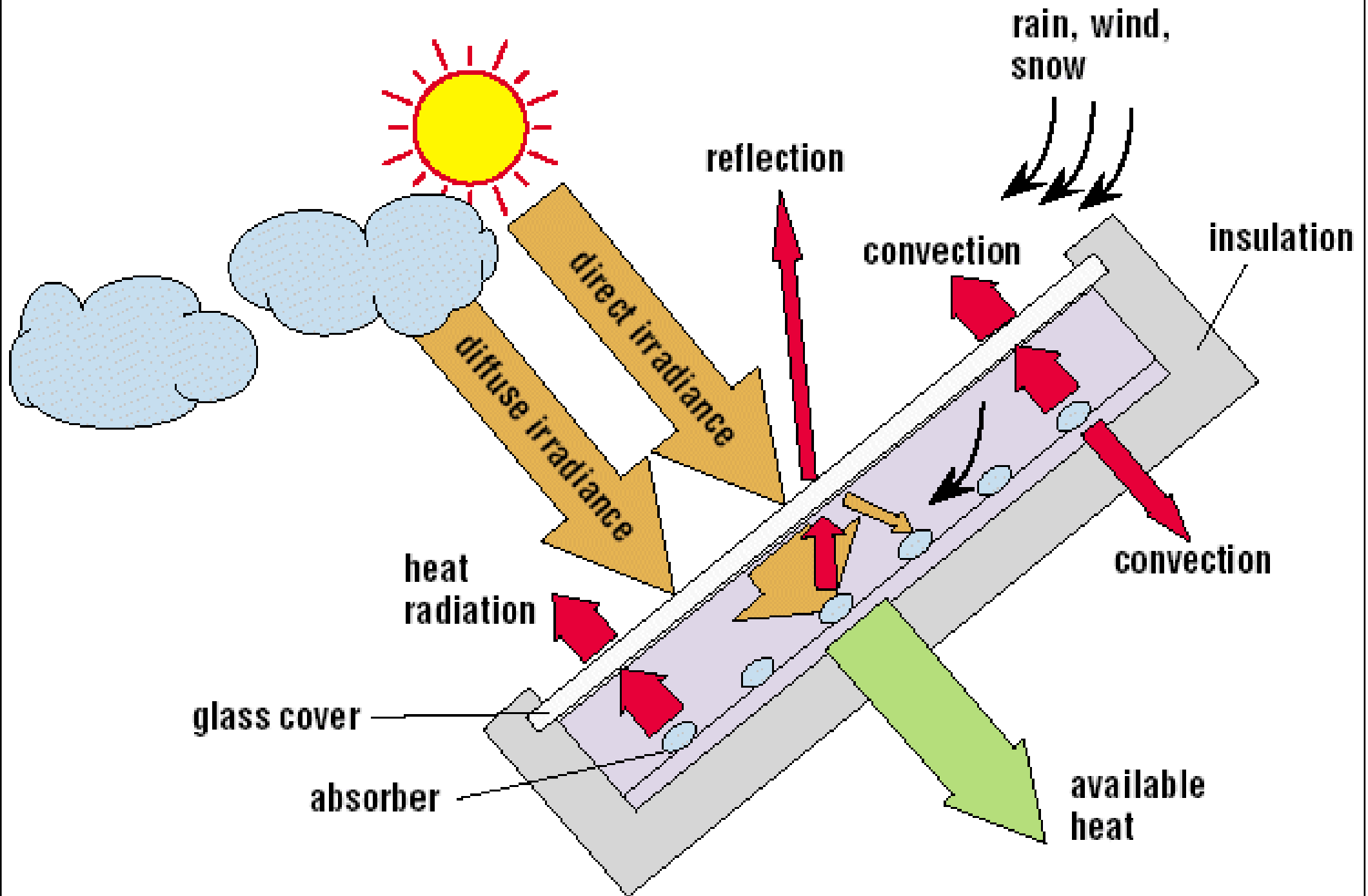

What should be the inclined angle and orientation for the solar collectors?



Inclined Angle?

Solar hot water for a school in Guangzhou

Principle of an evacuated tube collector with heat pipe

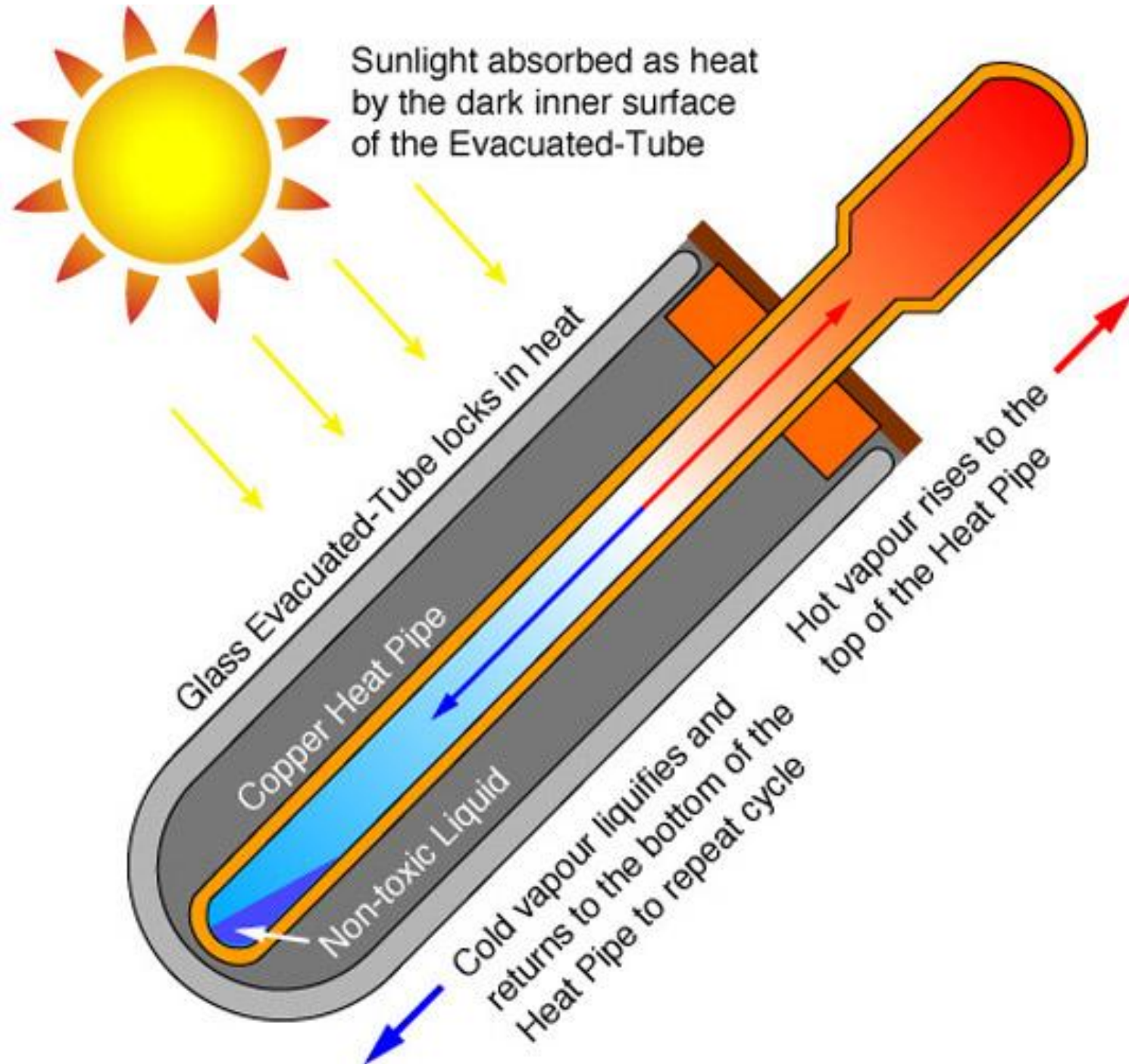



Storage tank

Collector

Evacuated-tube solar hot water system

Why Tibet is good for using solar energy?



Evacuated-tube solar hot water system in a hotel in Lhasa, Tibet
(photo taken by Dr Sam C M Hui)

A thermosyphon system

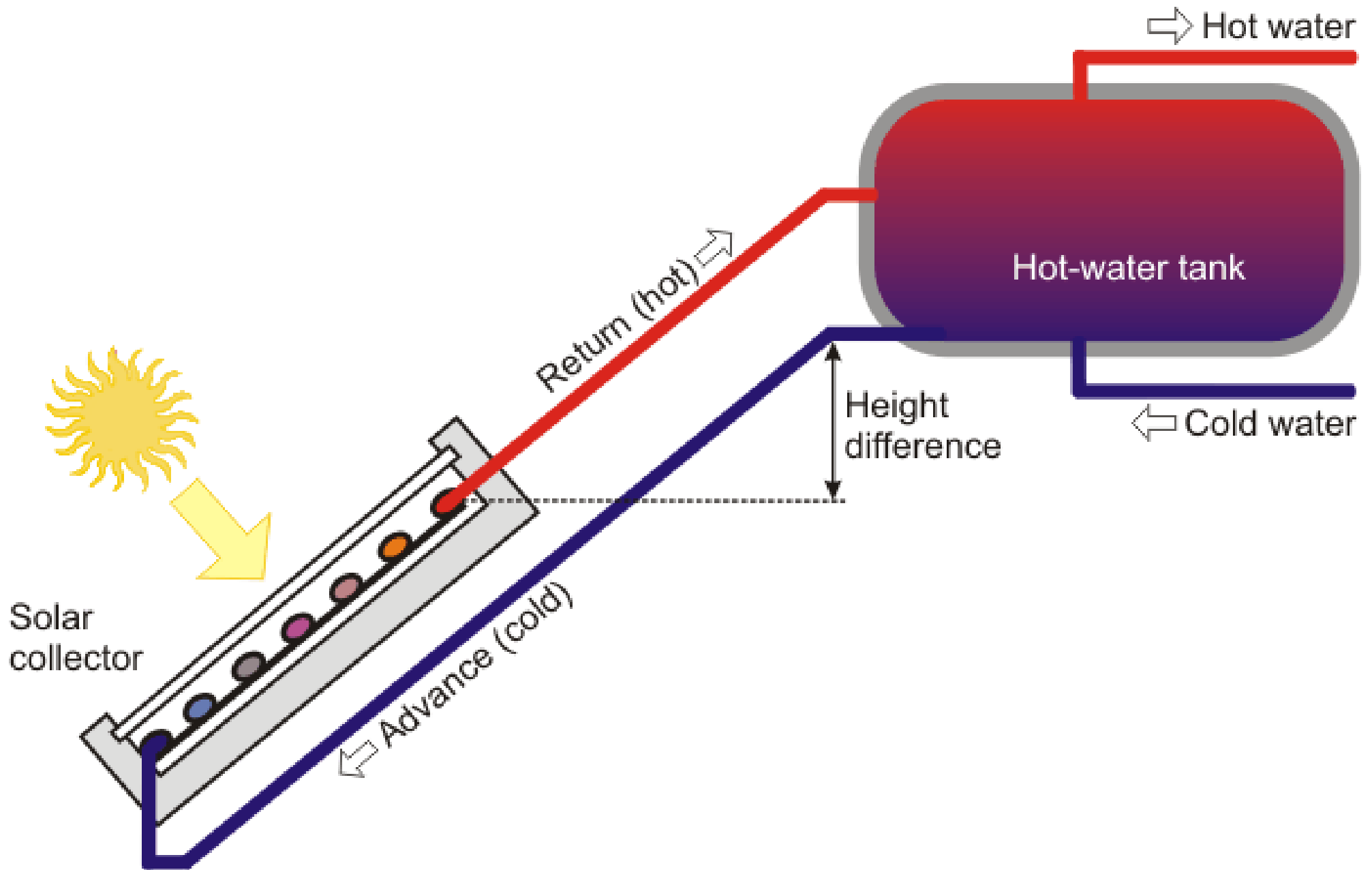

A double-cycle system with forced circulation with a conventional boiler for back-up heating

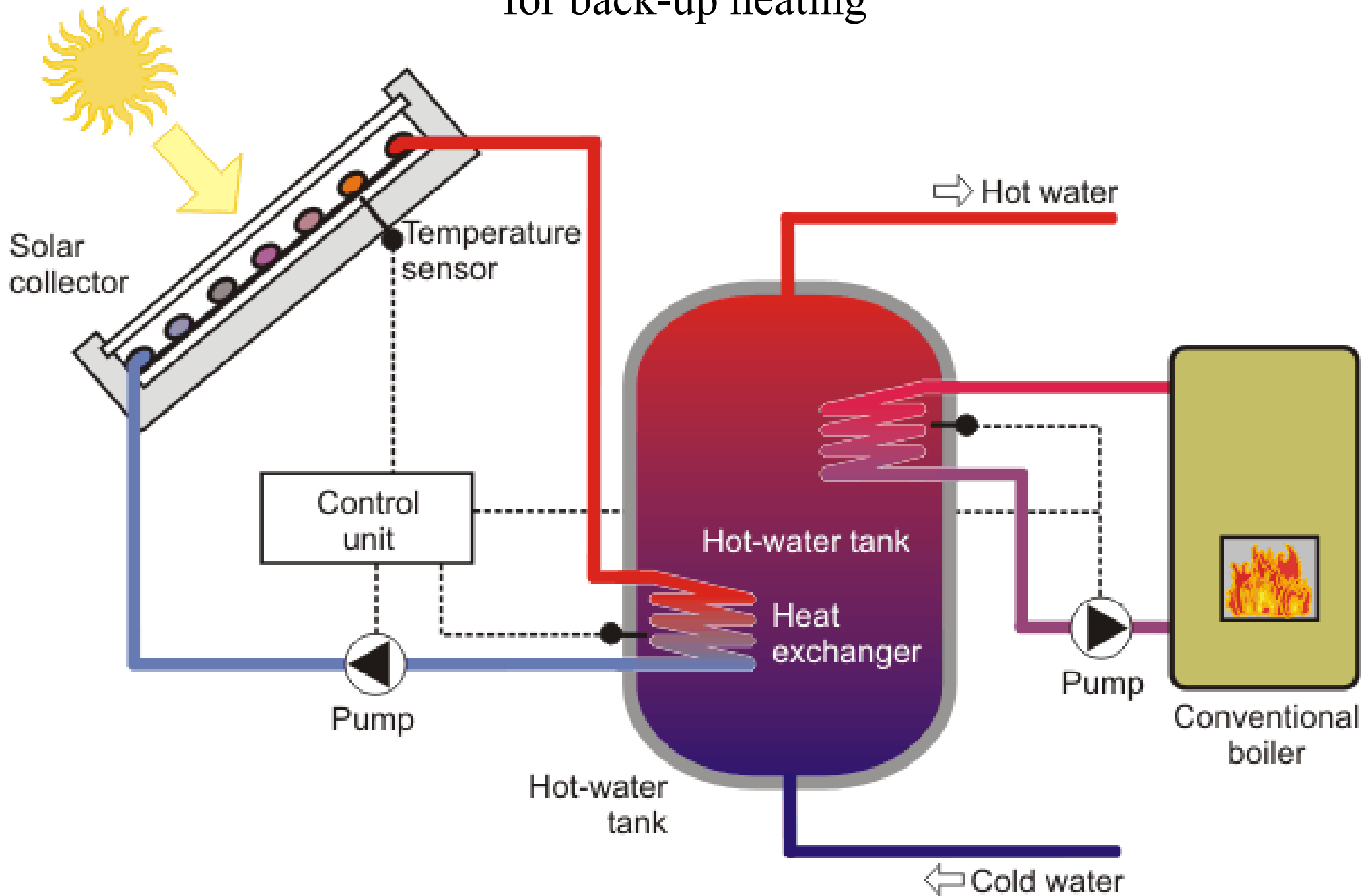

Concentrating solar power systems

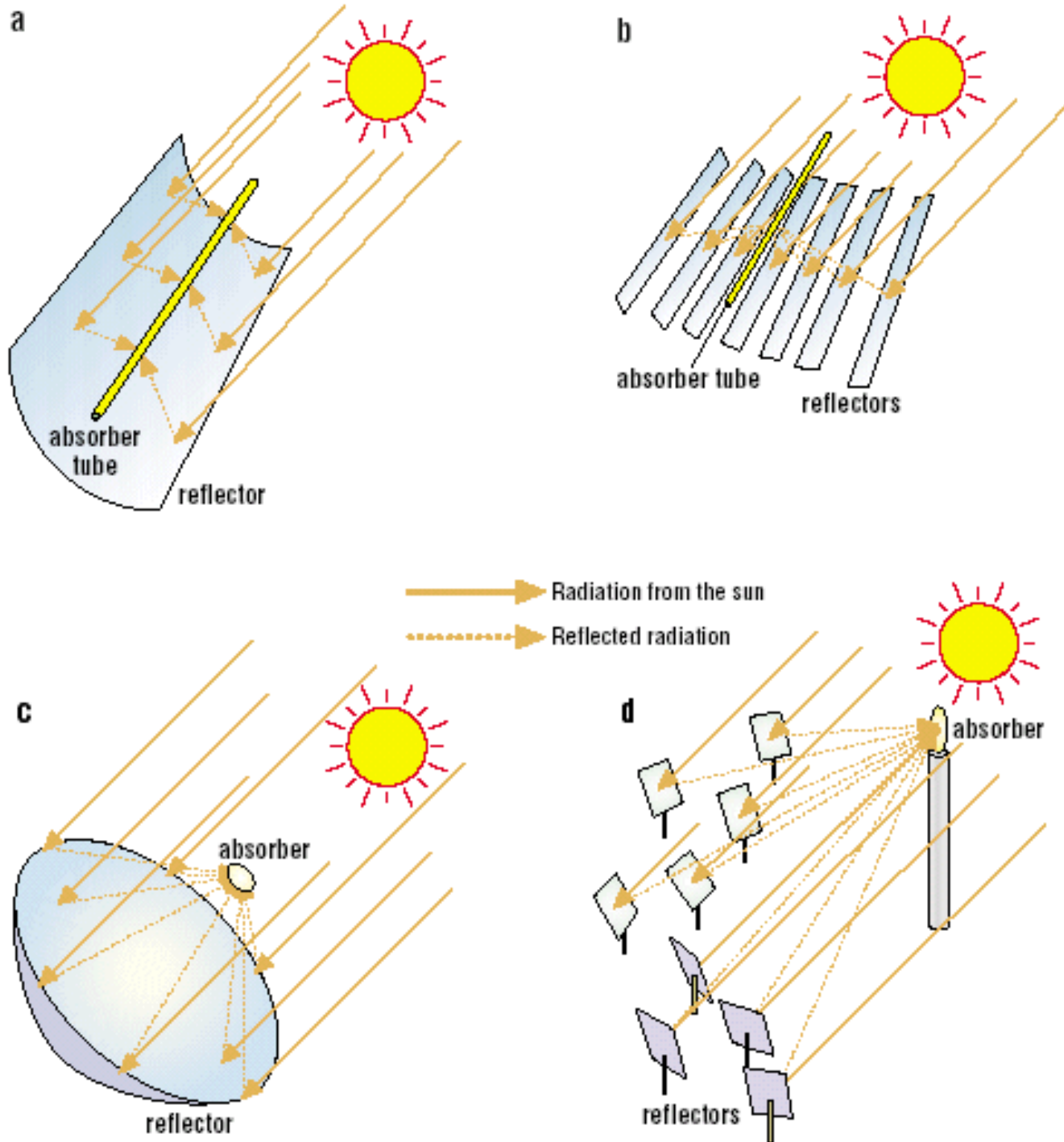

Schematic of a concentrated solar thermal trough power plant with thermal storage

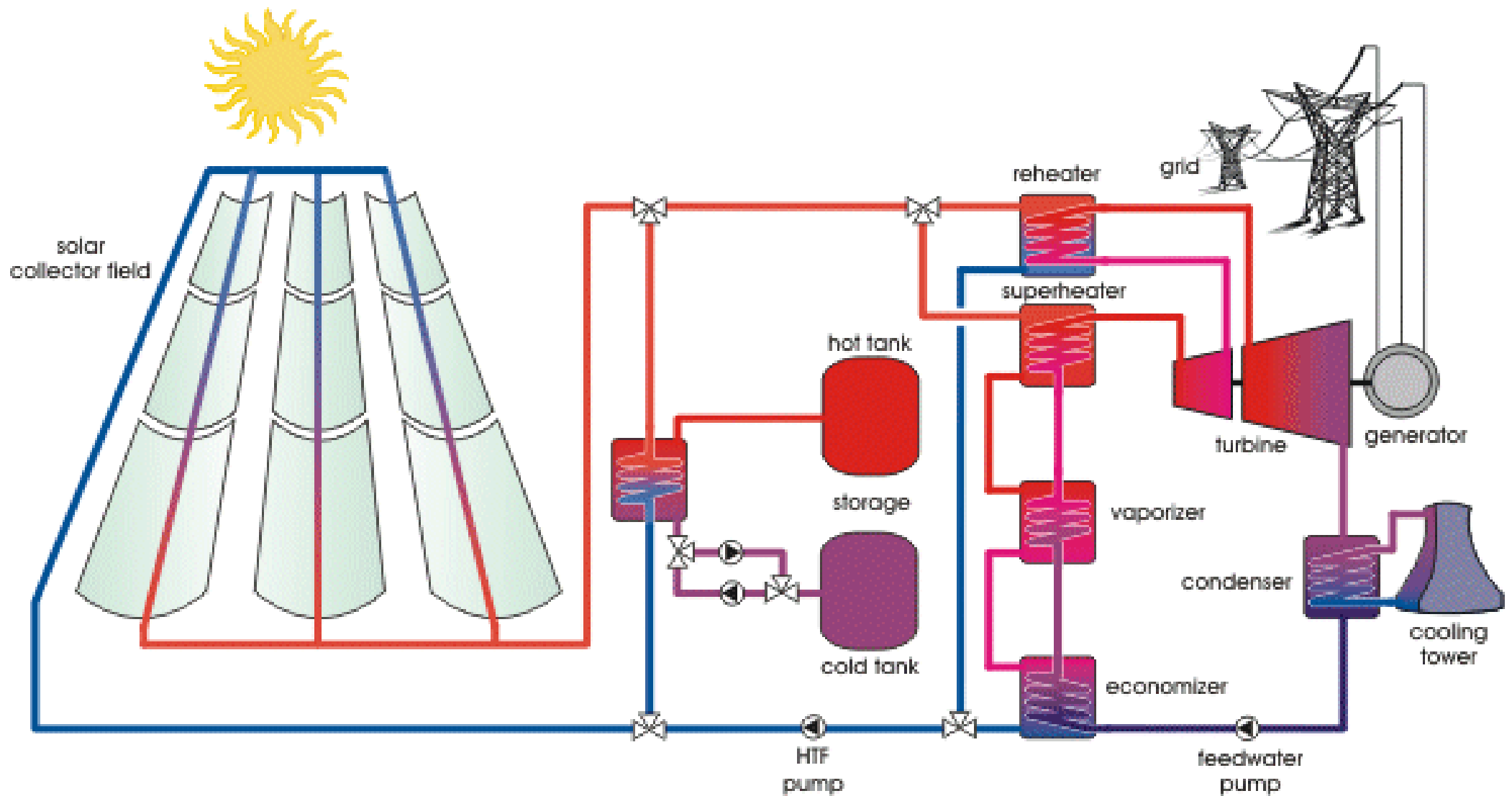

Schematic of two types of solar thermal tower power plant, showing (a) an open volumetric receiver with steam turbine cycle and (b) a pressurized receiver with combined gas and steam turbine cycle

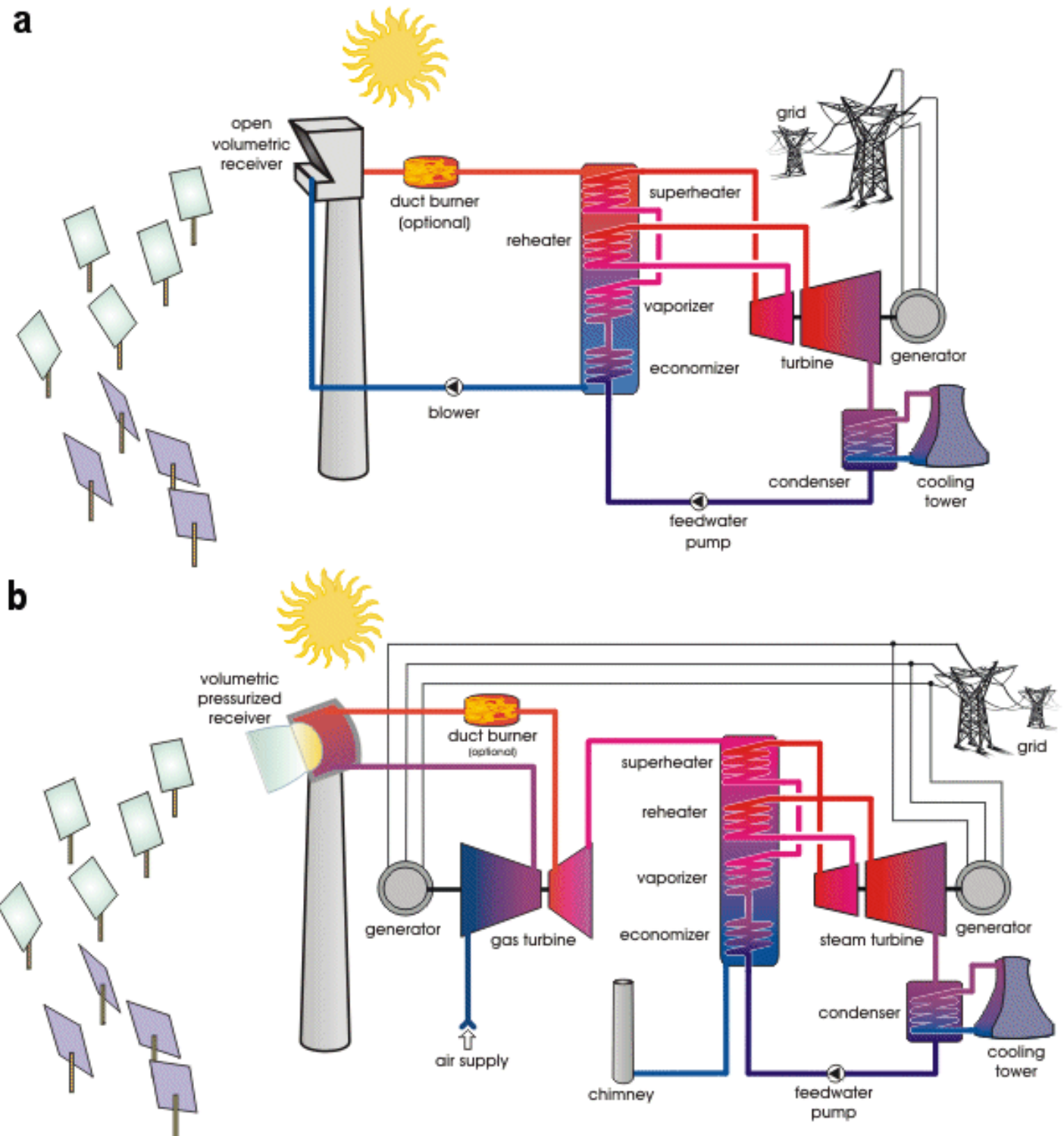

Photovoltaics



- Photovoltaics (PV)
 - Convert sunlight into direct current electricity using a semi-conductor device
 - Materials: crystalline and amorphous silicon (sand)
 - Applications:
 - Consumer products (e.g. calculator, radio)
 - Remote-site (e.g. remote telecom and weather station)
 - Central power generation
 - Building-integrated photovoltaic (BIPV) systems

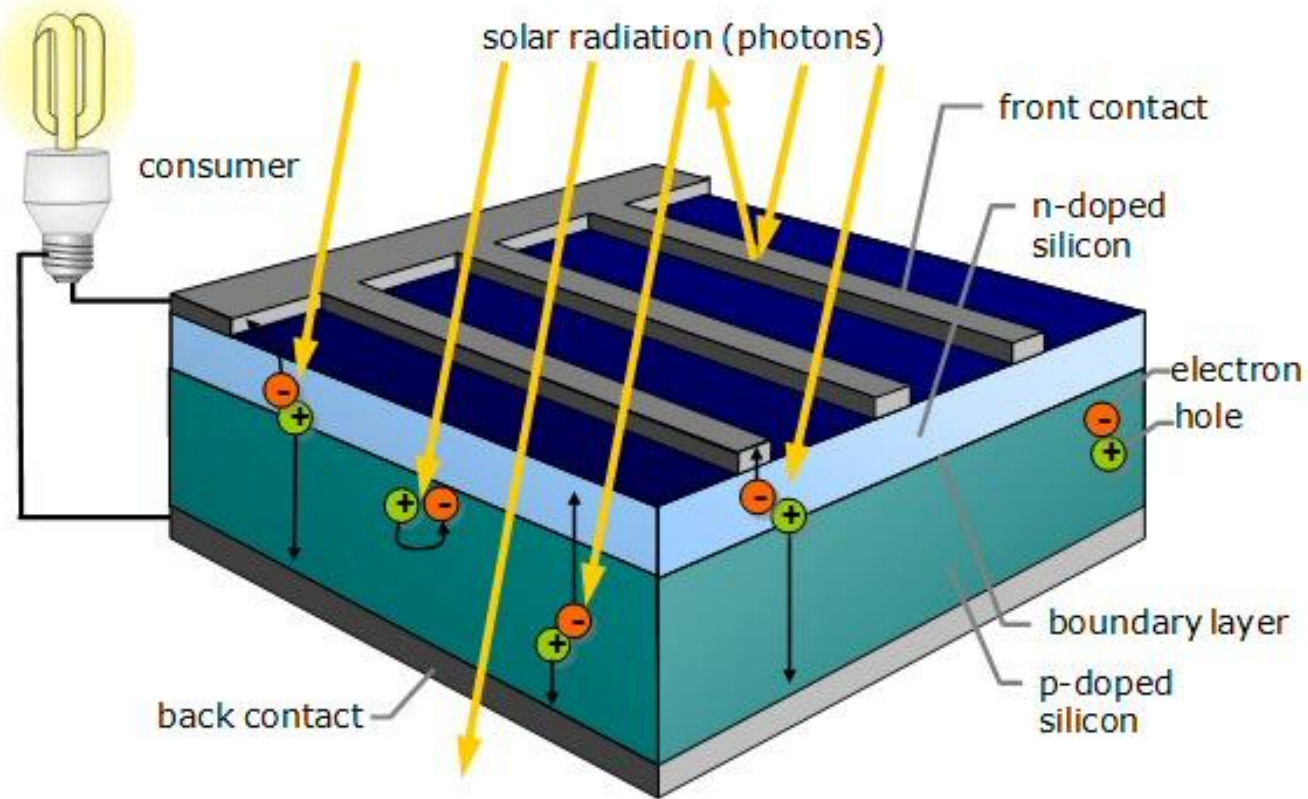

Principles of photovoltaic cells

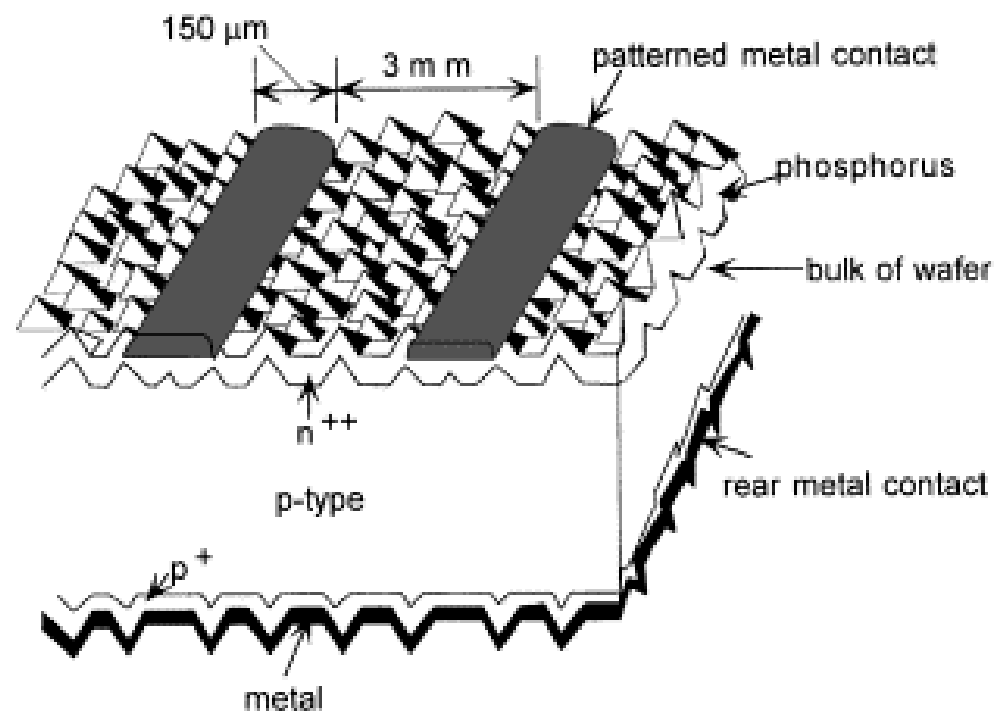

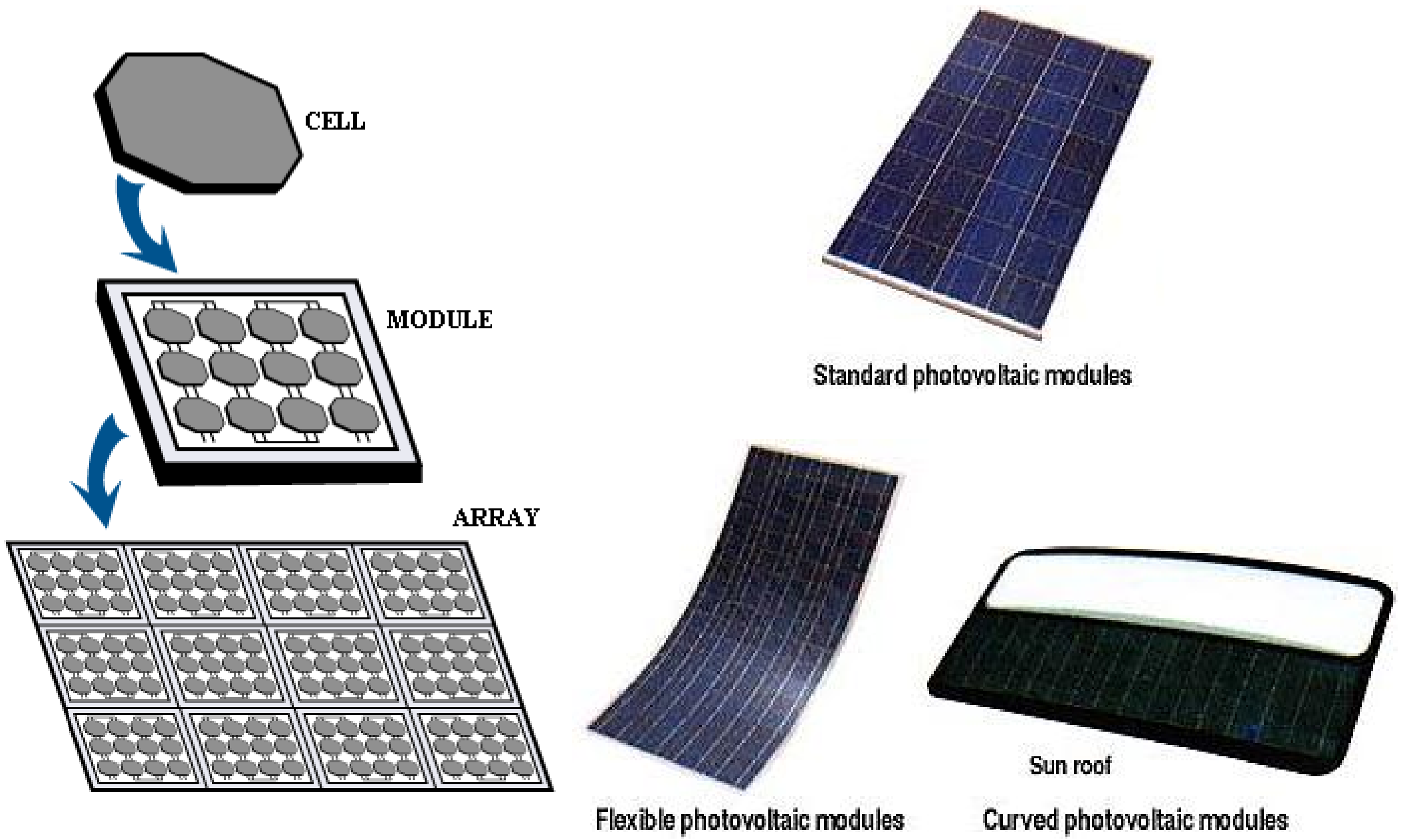

PV cells, modules and arrays

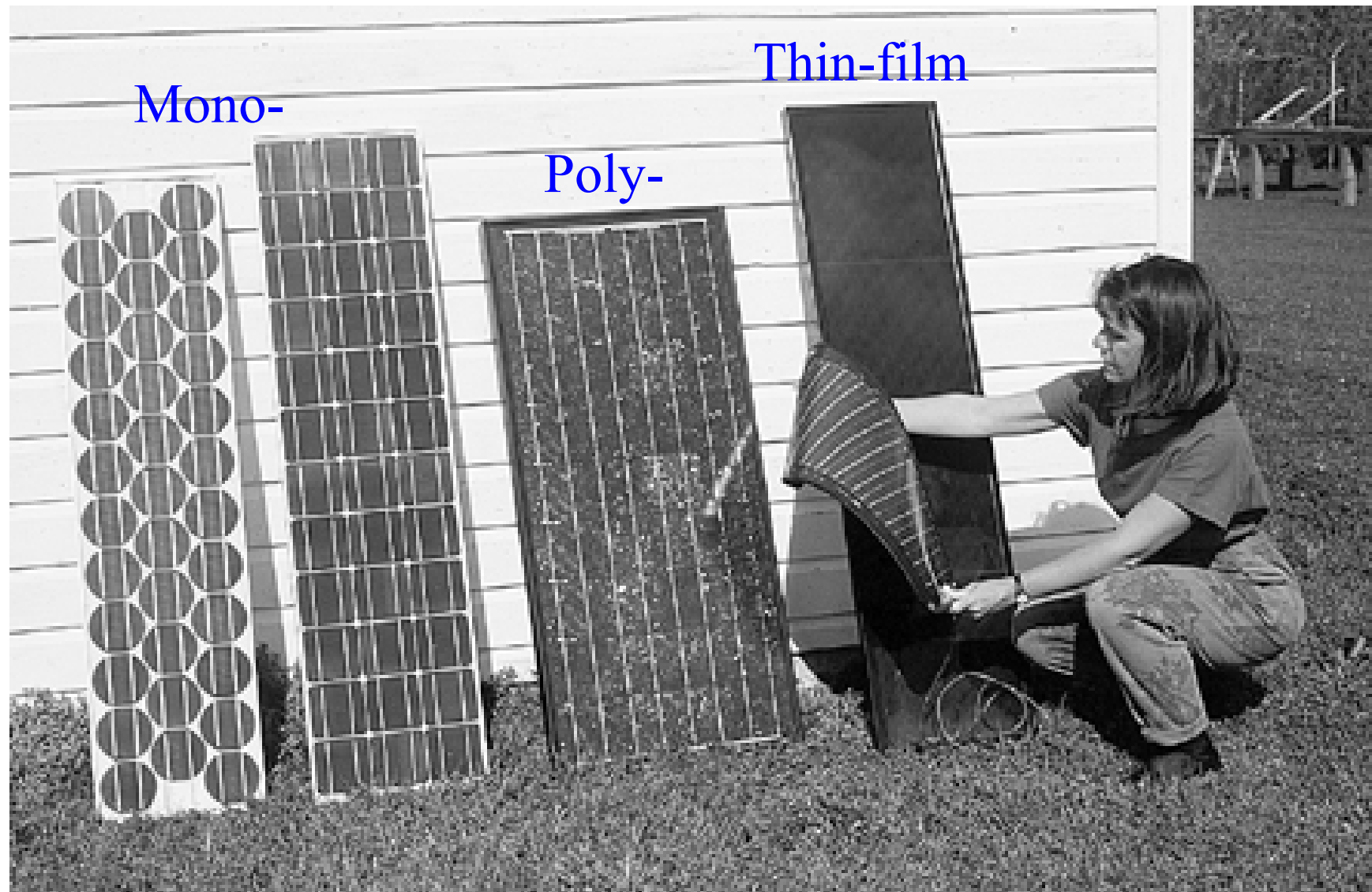

* Different types of PV modules (left to right): two mono-crystalline silicon modules (round and square-cut cells); a poly-crystalline silicon module; and two thin-film modules (rigid and flexible)

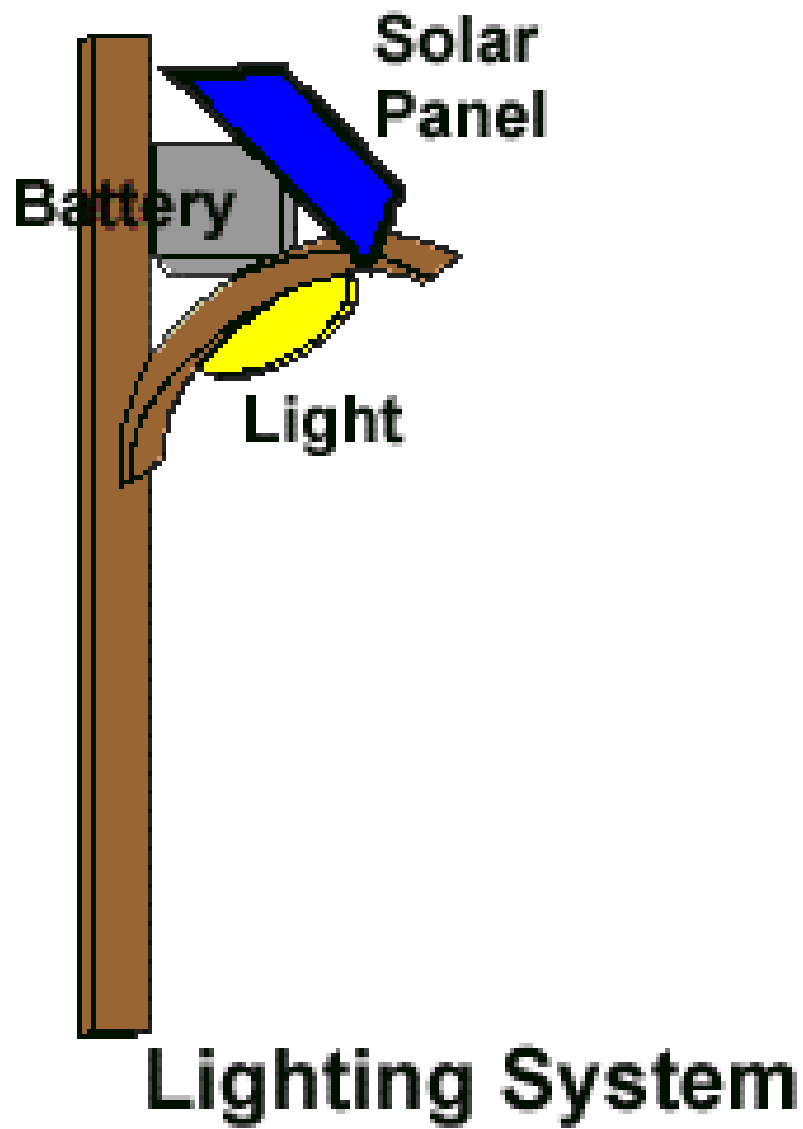

PV lighting system

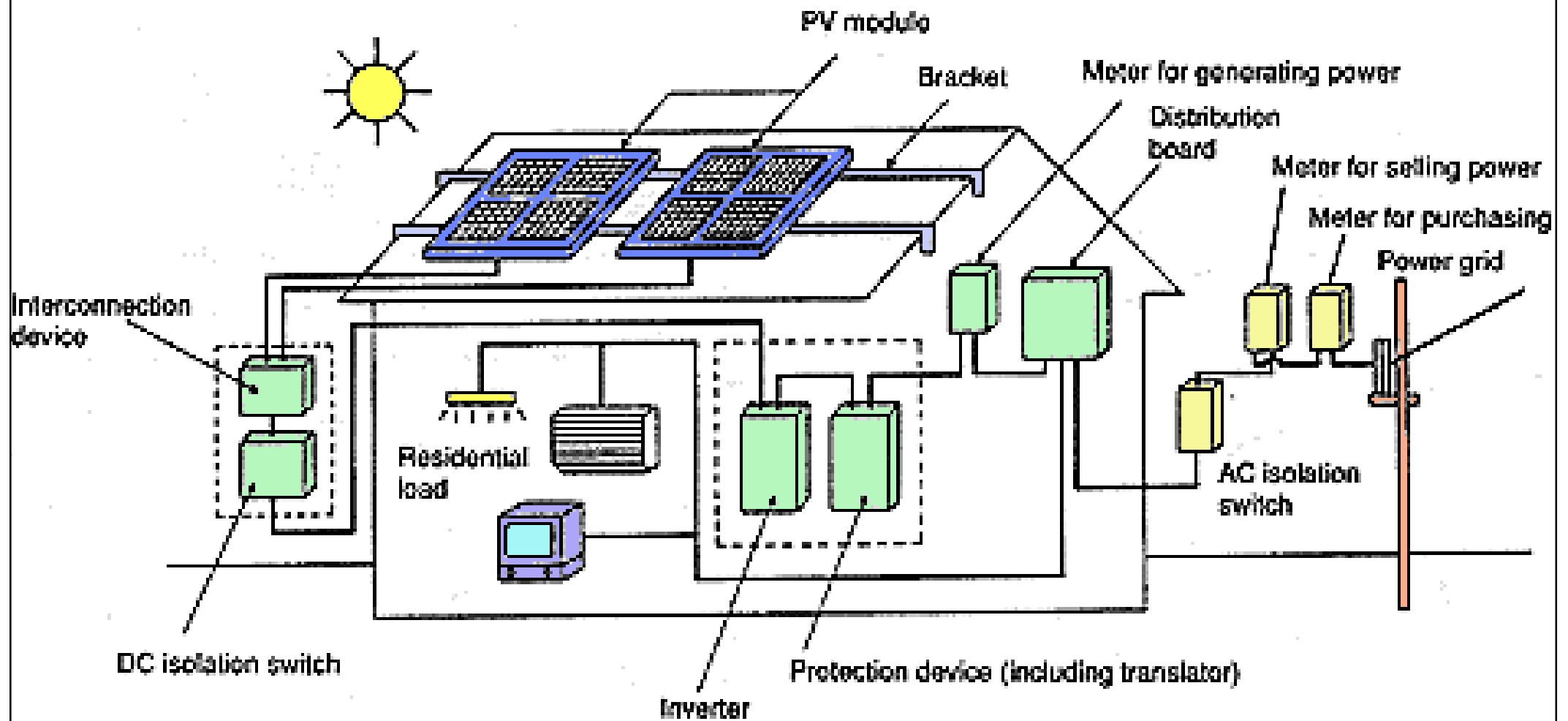

Conceptual drawing of a residential PV system

Photovoltaics



- Building integrated PV (**BIPV**):
 - Improve cost effectiveness and functions
 - Dual use (PV + building envelope)
 - No need for extra land and support
 - Can be integrated with
 - Exterior wall panels, roof tiles
 - Exterior shading systems, parapet units
 - Skylights or atriums
 - Semi-transparent glass facades

* Locate array in an unshaded area facing the equator

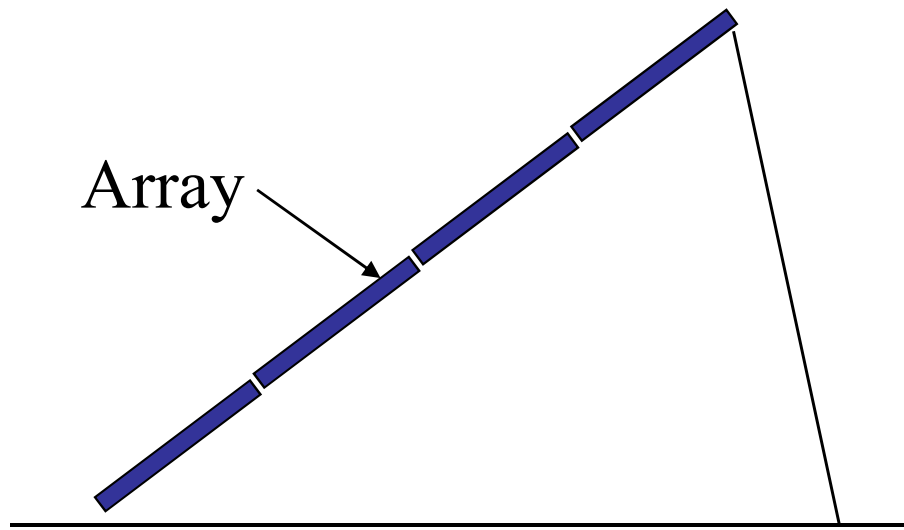

$$\text{Tilt angle} = \text{latitude } (^{\circ}) + 15^{\circ}$$

(a) Roof (horizontal)

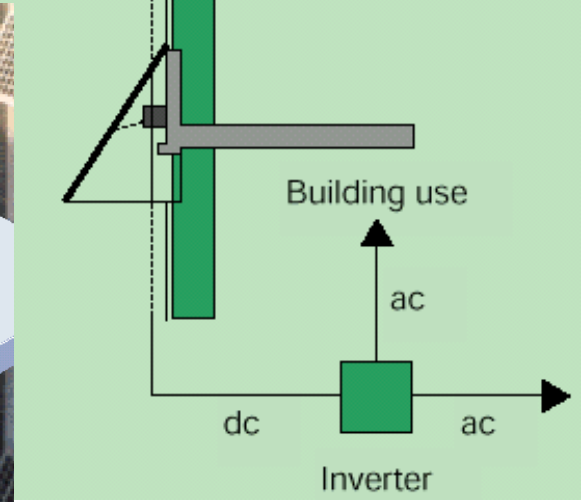
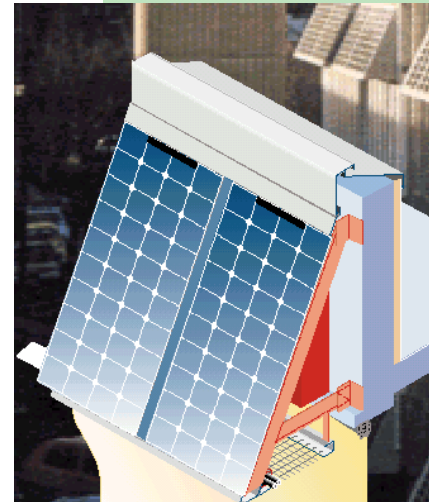
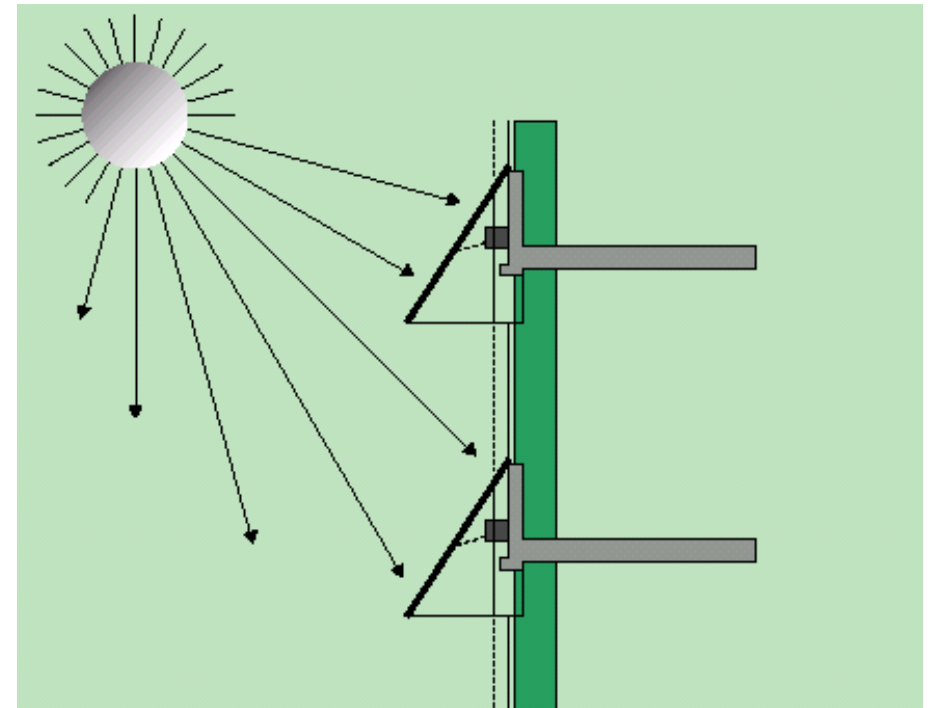

(b) Facades (vertical)

PV installations in buildings



(a) Colour PV modules

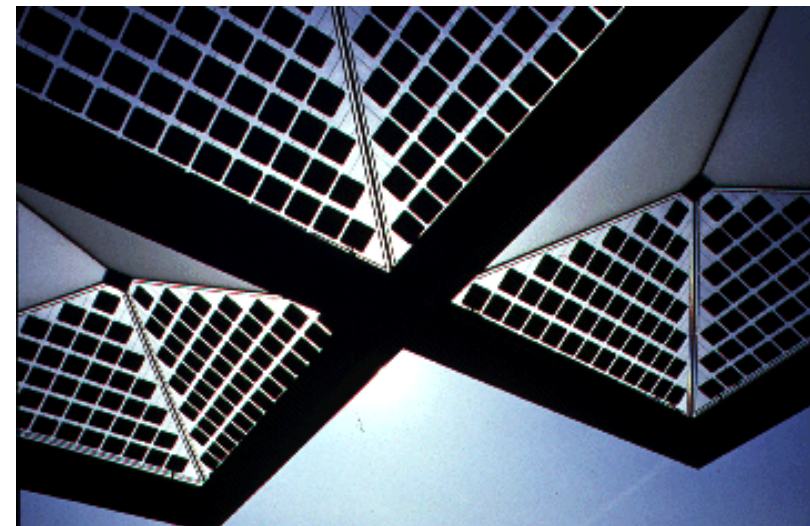
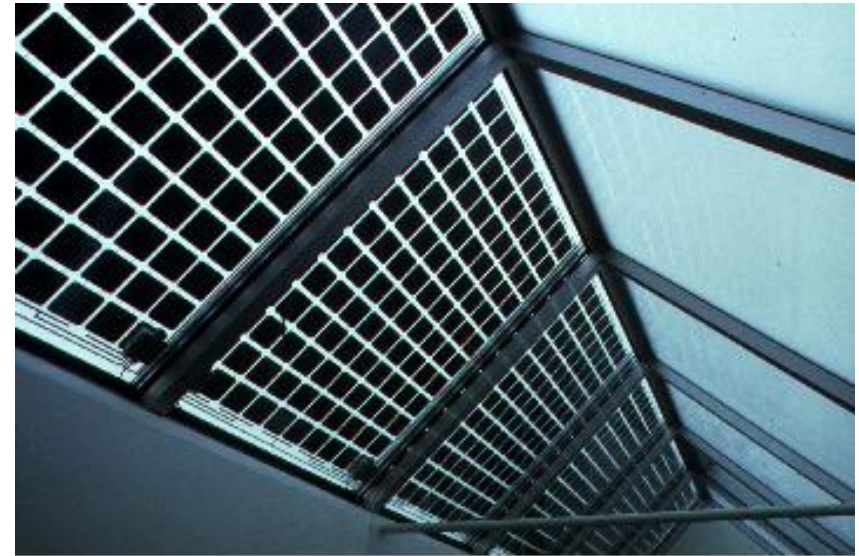

(b) Semi-transparent PV screens



PV integration on walls



PV integration on roofs



(PV system for Olympic Village, Atlanta)



Other structures integrated with PV

Wind energy



- Formation of wind
 - Solar radiation heats up different parts of the earth at different rates
 - Warm air rises in region that gains more solar heat and the cold air from the adjacent region displaces the warm air. As a result, wind, an horizontal airflow, is formed

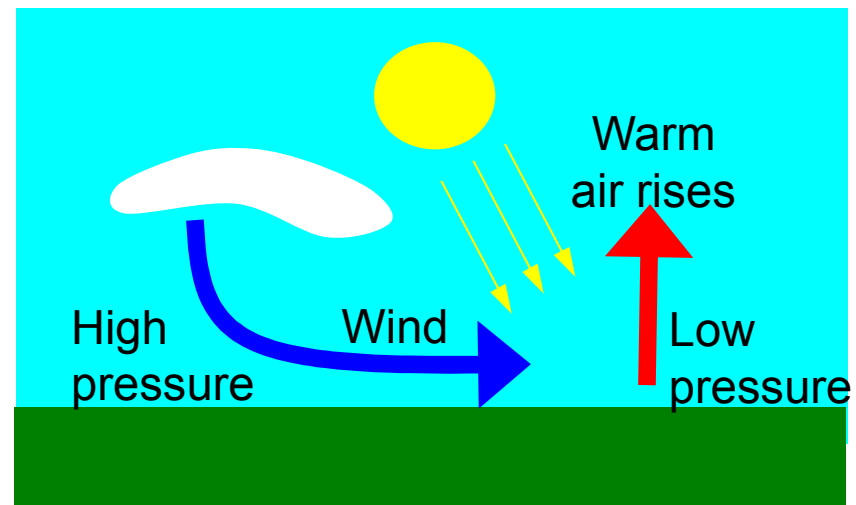
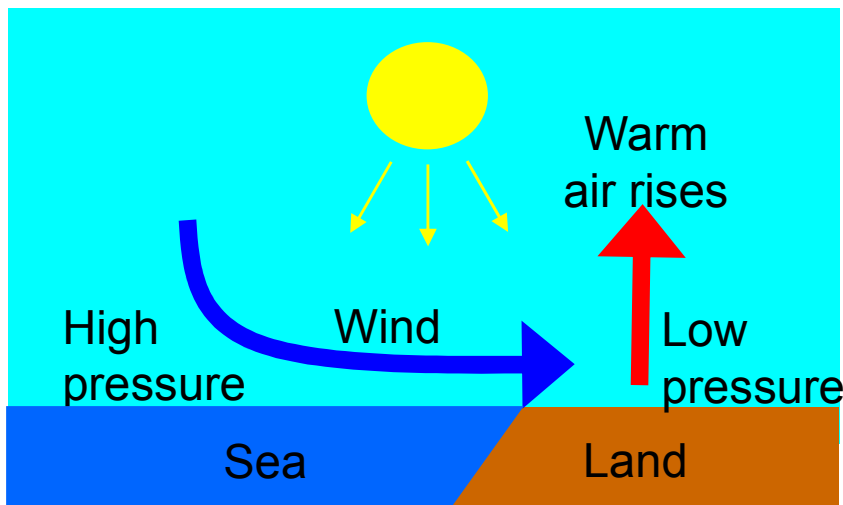

Kinetic Energy of Wind

Air has mass, and when it is in motion, it possesses kinetic energy.

For a mass (m), kinetic energy (E) is

$$E = \frac{1}{2} m V^2 \text{ [J]}$$

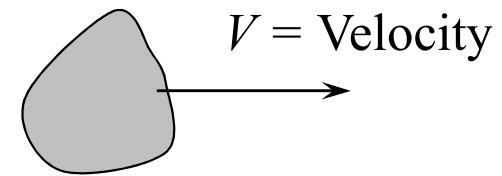

For a parcel of air, kinetic energy (E) is

$$E = \frac{1}{2} \rho v V^2 \text{ [J]}$$

ρ = Density
 v = Volume

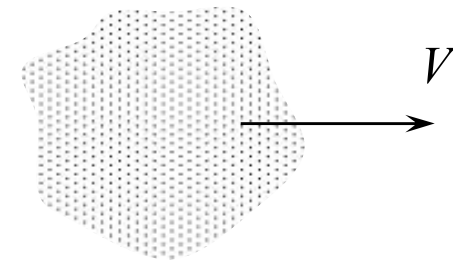

For a continuous airflow, power of wind (P) flowing through a normal surface area A is

$$P = \frac{1}{2} \dot{m} V^2 = \frac{1}{2} \rho A V V^2 = \frac{1}{2} \rho A V^3 \text{ [W]}$$

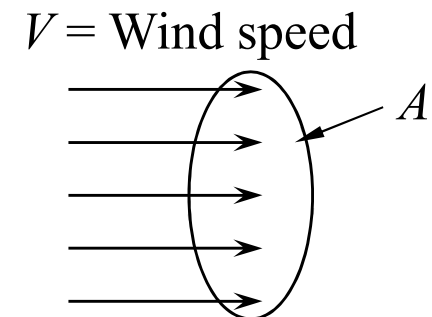

Example

Given the following information:

- Wind speed = 6 m/s
- Air density at 30°C = 1.165 kg/m³
- Rotor radius of a wind turbine facing the wind directly = 25m

What is the power of incoming wind blowing the wind turbine?

Answer:

$$\begin{aligned} P &= \frac{1}{2} \rho A V^3 \\ &= \frac{1}{2} \times 1.165 \times (\pi 25^2) \times 6^3 \\ &= 247,047 \text{ W} = 247 \text{ kW} \end{aligned}$$

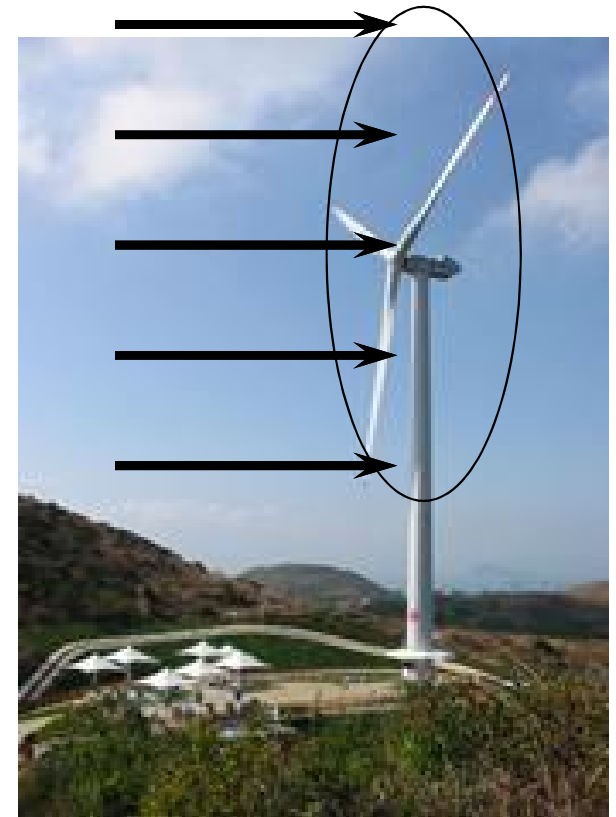

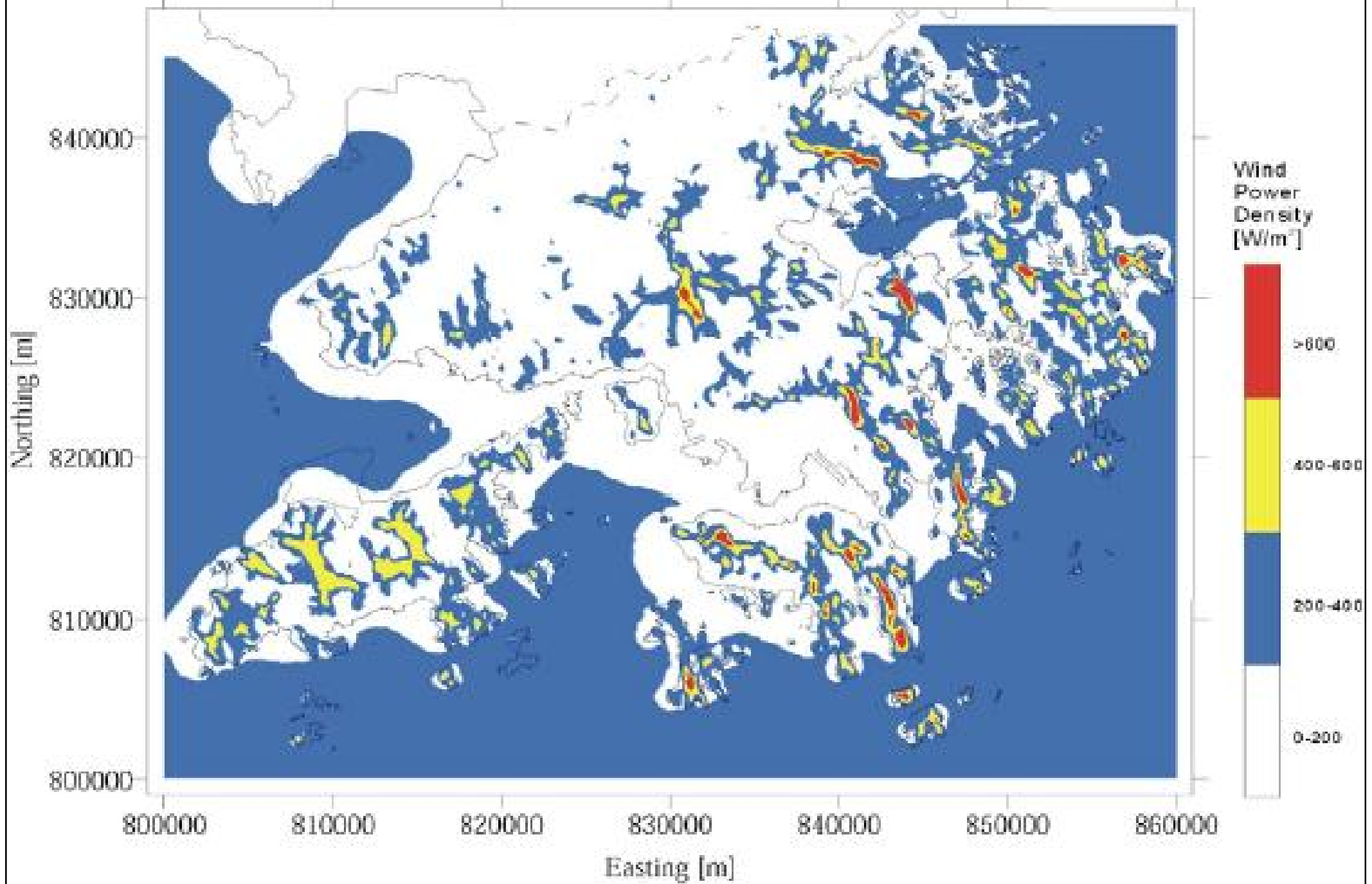

Wind power density over the region of Hong Kong (from EMSD)

Wind power potential in China

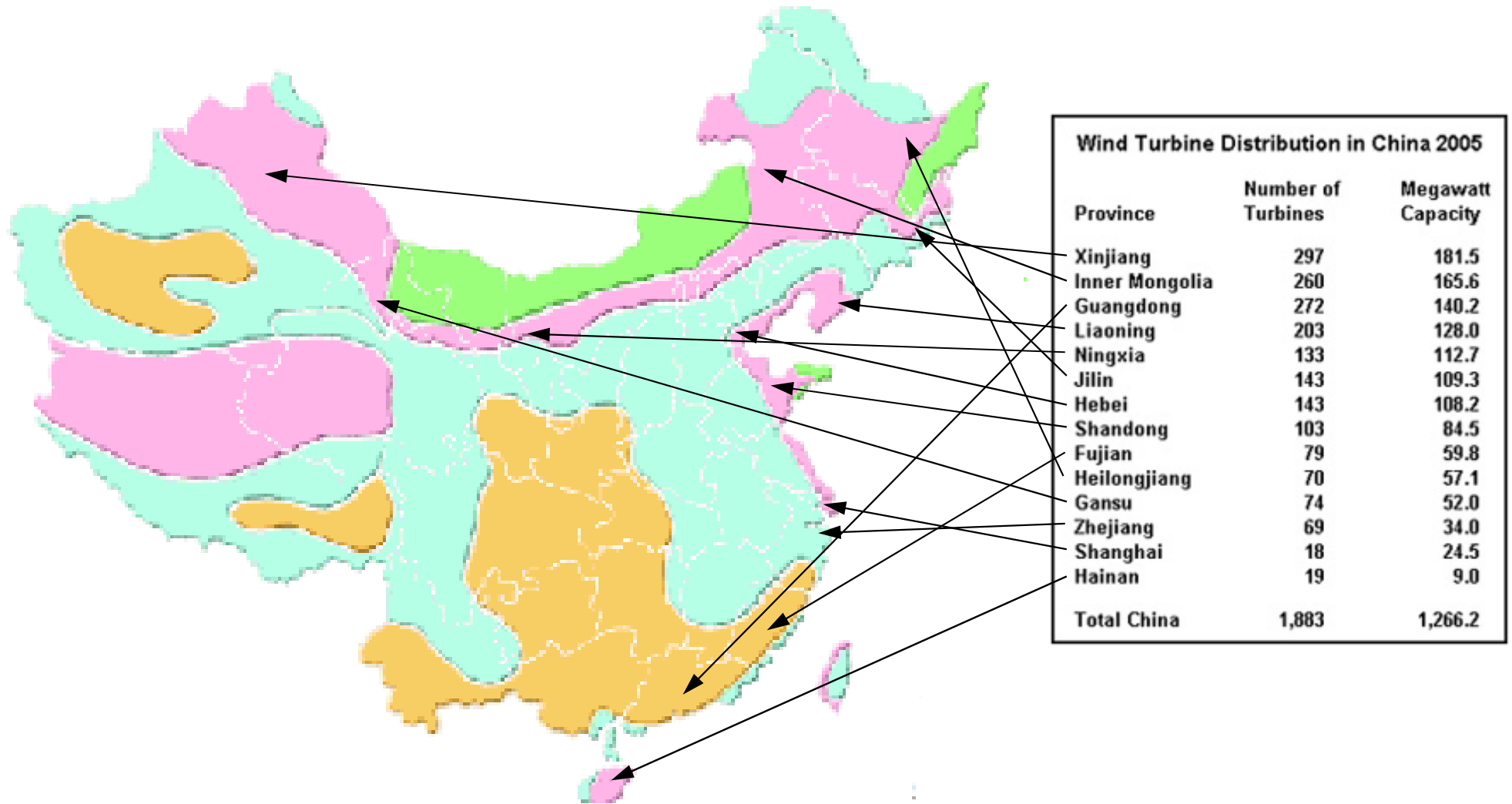

Green=great, **Pink**=good, **Blue**=medium, **Yellow**=poor

Ref.: EcoWorld Nature & Technology in Harmony, 2006

Horizontal-Axis Wind Turbine (HAWT)

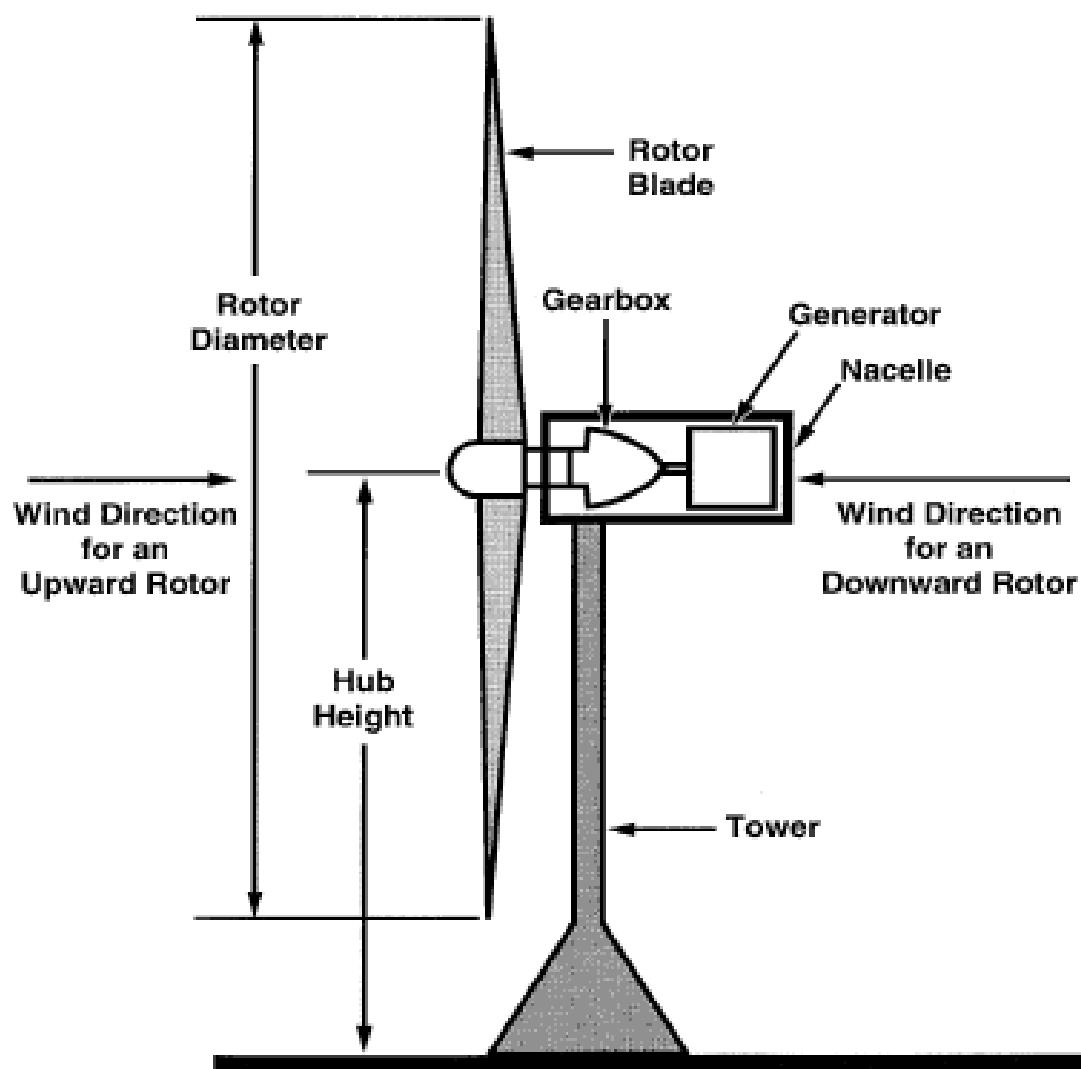

Vertical-Axis Wind Turbine (VAWT)

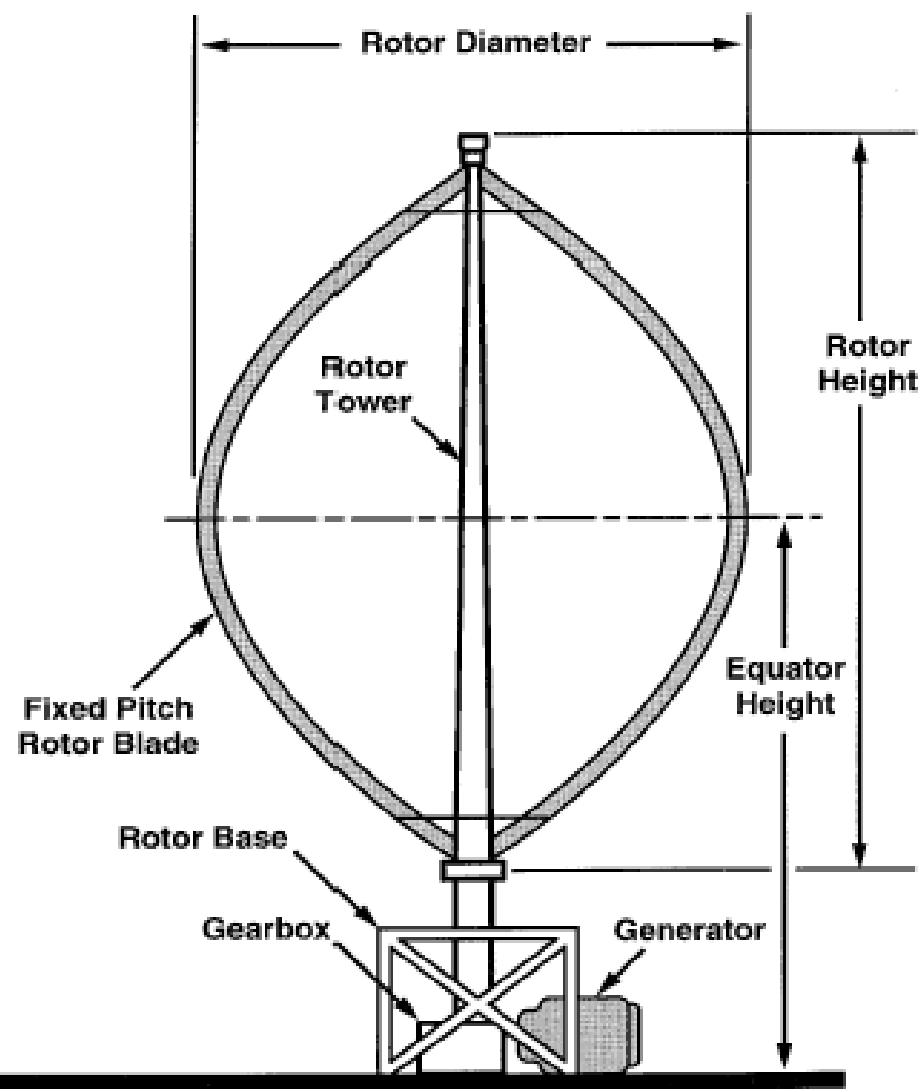



Wind turbines on inland or islands



Off-shore wind turbines

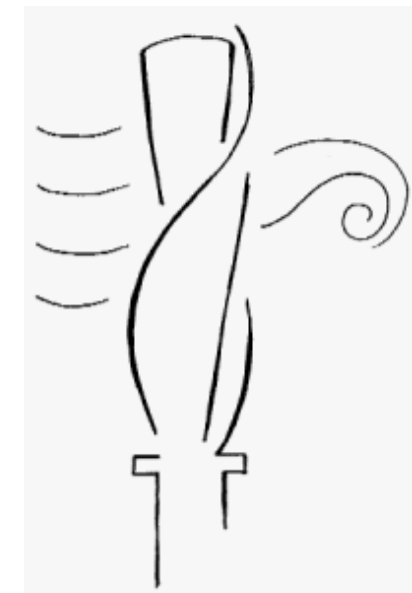

Vertical axis wind turbines

Building integrated wind turbines (proposed WTC towers in Bahrain)



Pearl River Tower,
Guangzhou

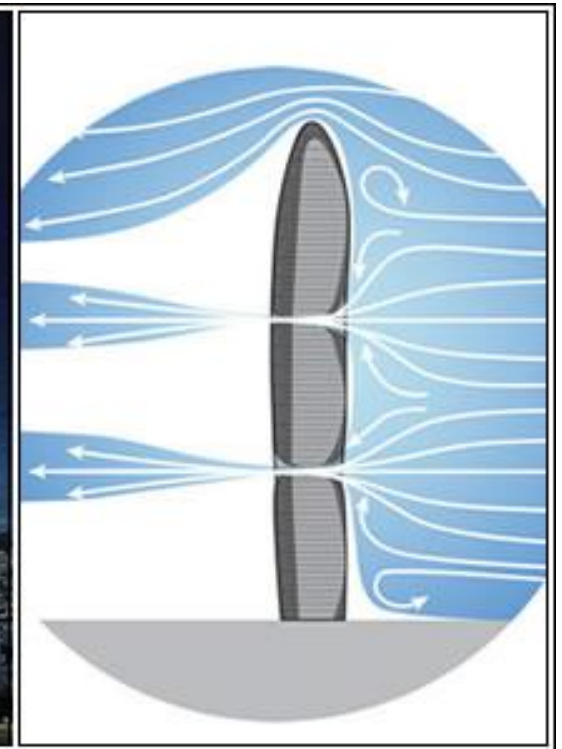

Wind energy



- Design factors

- Location: inland or off-shore

- e.g. wind farm

- Wind turbines:

- Horizontal or vertical axis

- Wind speed

- Cut-in = 3-5 m/s; shut-down = 25-27 m/s

- Environmental impact

- e.g. noise, visual, electromagnetic interference



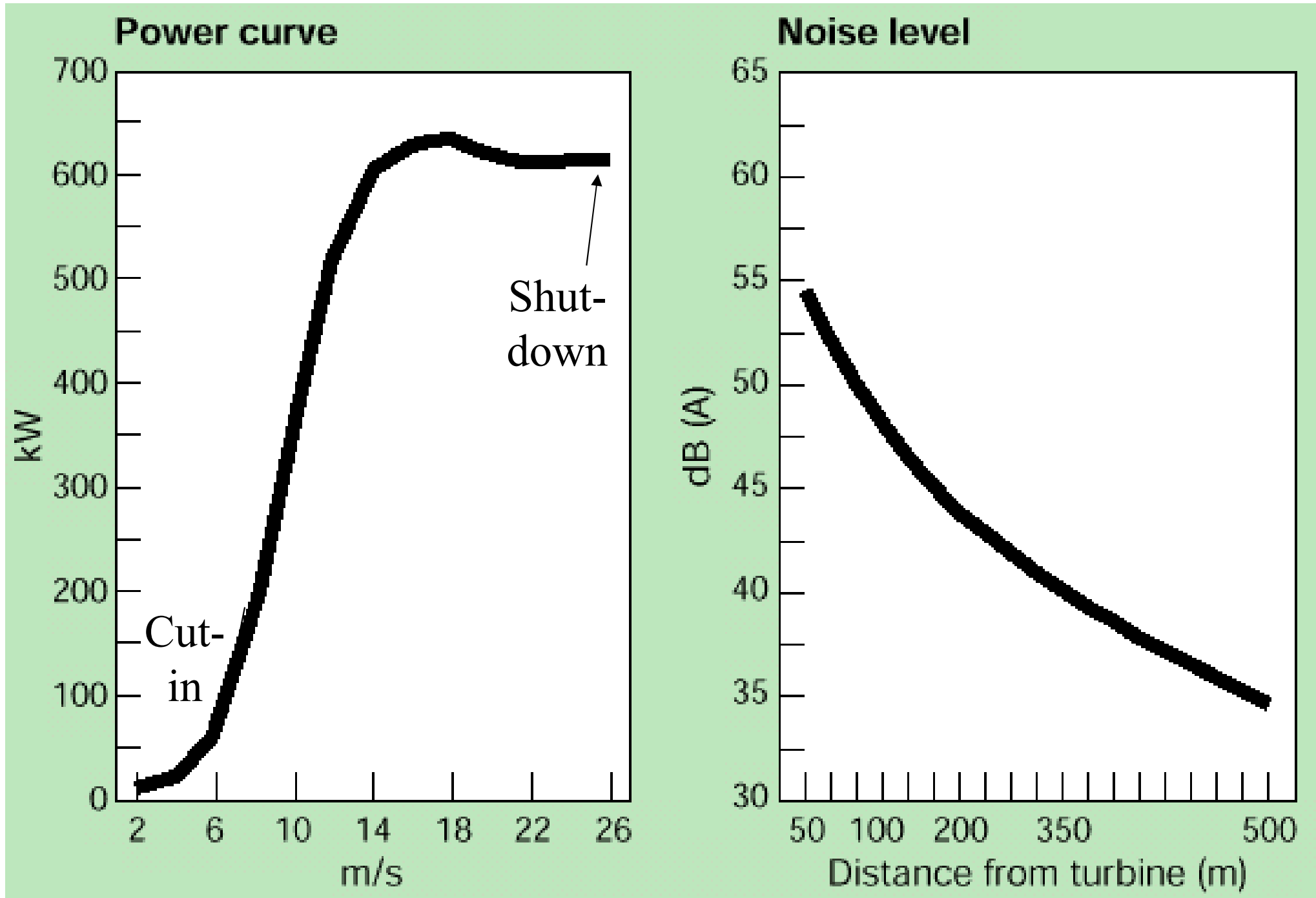

Power curve and noise level of wind turbines



Biomass energy

- Biomass energy or “bioenergy”
 - Using wood, agricultural residues as a fuel
 - Energy from waste incineration or digestion
 - Landfil gas, biogas and biofuel

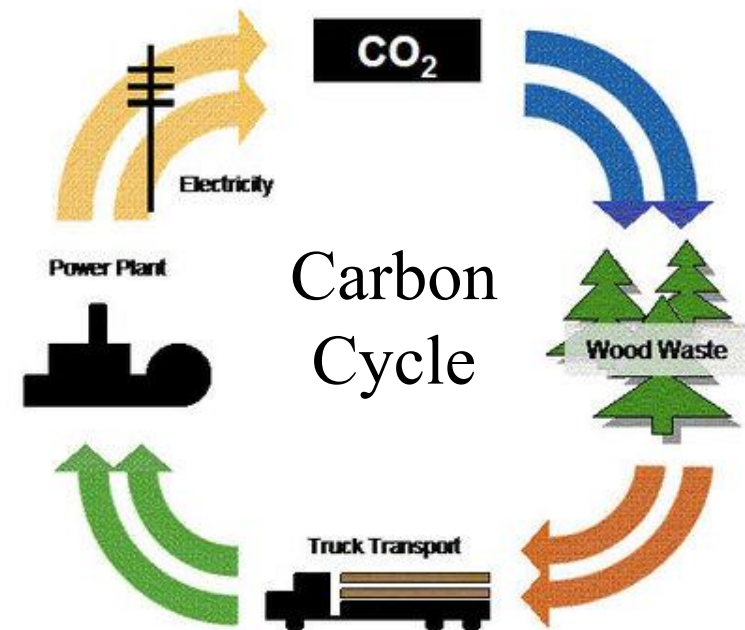

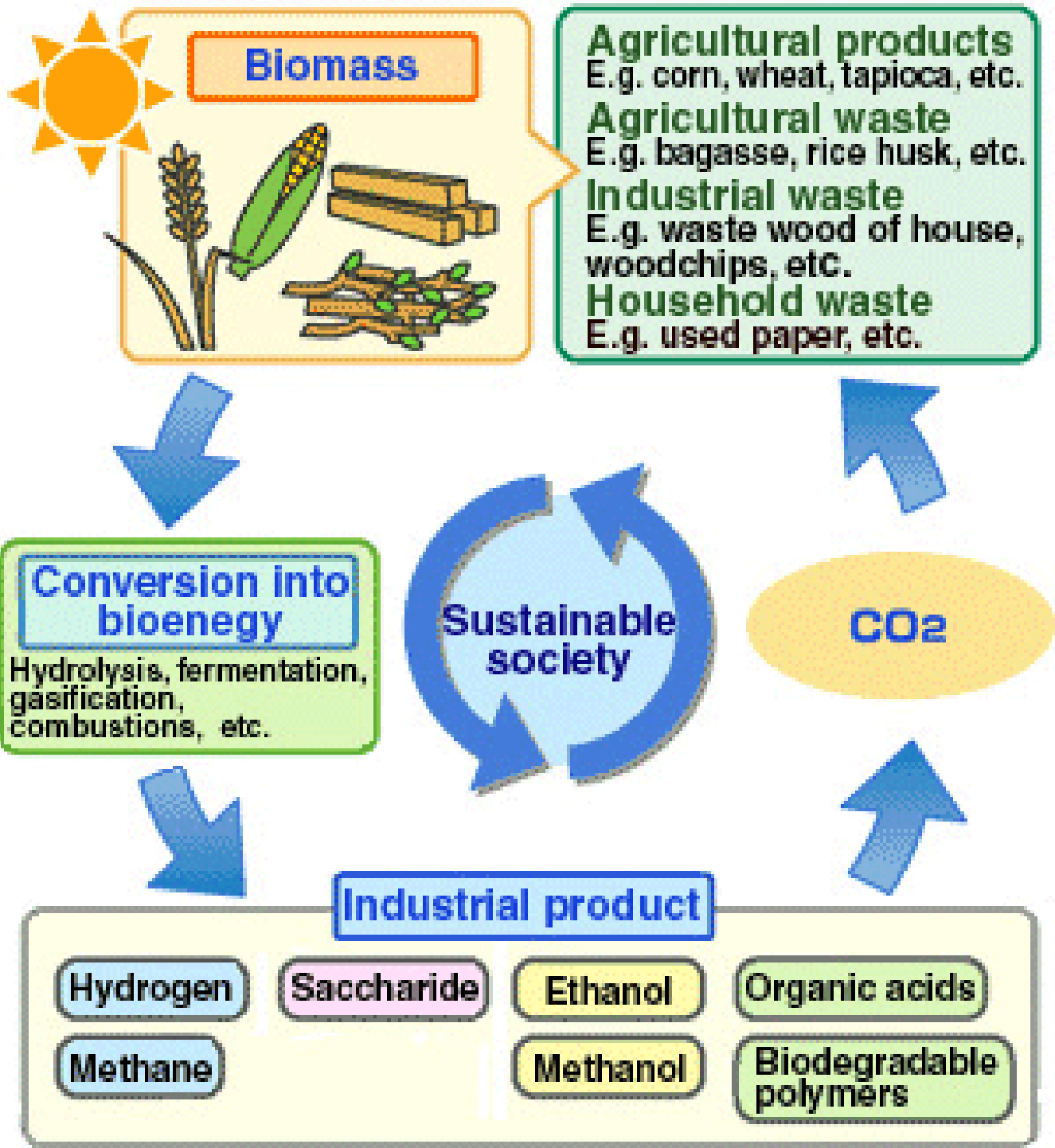



Biomass energy

- Common applications
 - Biofuels: converting biomass into liquid fuels for transportation, e.g. ethanol and biodiesel
 - Biopower: burning biomass directly, or converting it into gaseous or liquid fuels that burn more efficiently, to generate electricity
 - Bioproducts: converting biomass into chemicals for making plastics and other products that typically are made from petroleum

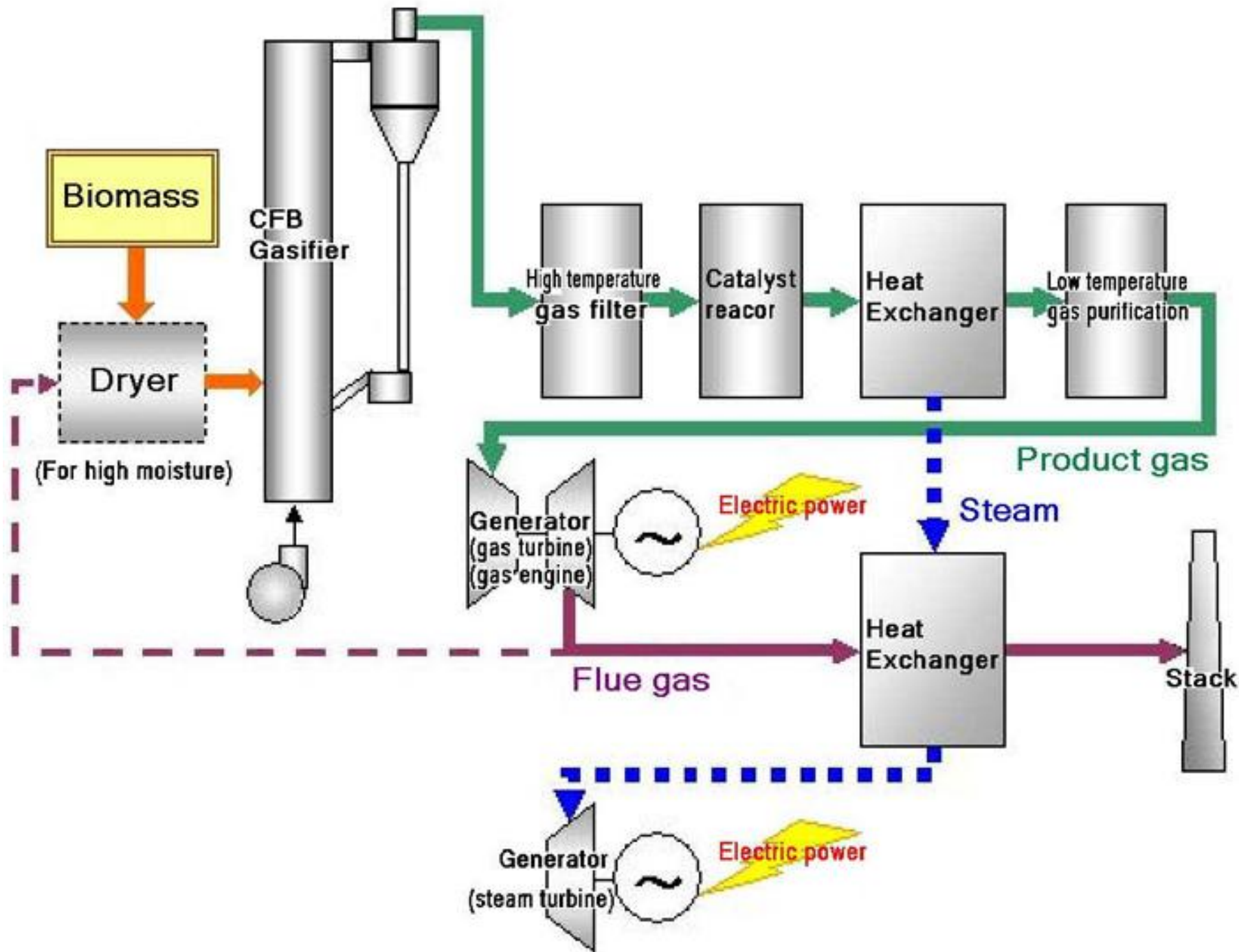

Biomass gasification system for power generation

(Source: www.takuma.co.jp)

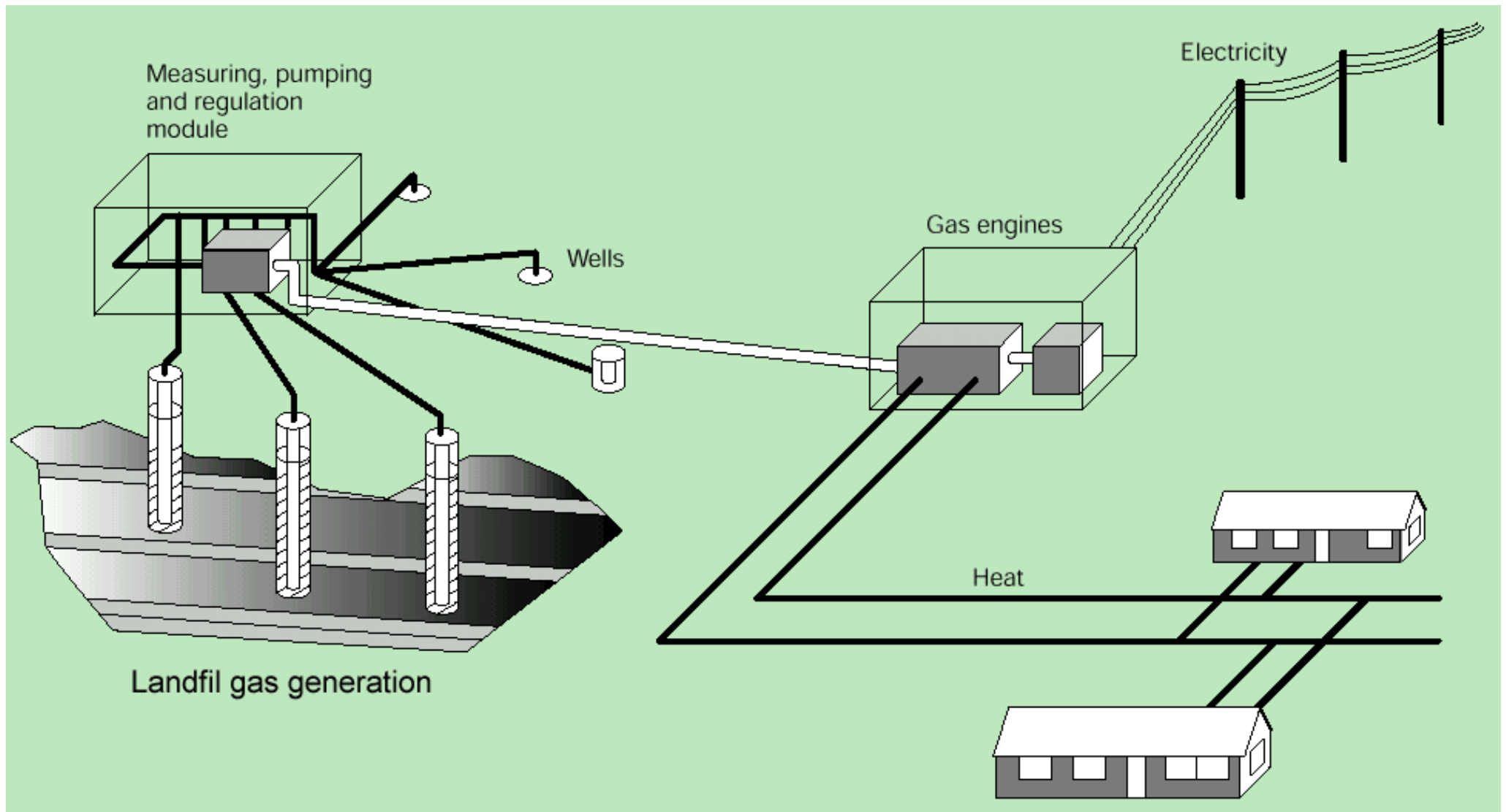

Use of landfil gas for electricity and heat

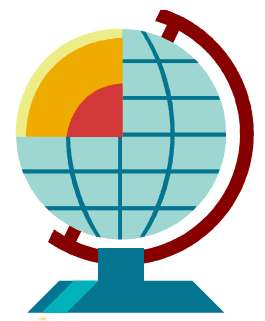

Geothermal energy

- Geothermal energy = the heat from the earth
 - Deep in the earth or near the earth's surface
- Typical geothermal applications:
 - Direct use: produce heat directly from hot water within the earth
 - Electricity production: Generate electricity from the earth's heat
 - Geothermal heat pumps: Use shallow ground to heat & cool buildings (ground-source heat pump)

HARNESSING GEOTHERMAL ENERGY

Geothermal power could theoretically satisfy all the world's energy needs. Trouble is, it's expensive to do the deep drilling necessary to tap the heat.

HOW IT WORKS

1 A deep production well is dug to an underground steam reservoir.

2 The pressurized steam is released and piped to a power plant, where its force turns a turbine.

3 The turbine powers a generator that converts the rotational energy into electricity.

4 The steam is condensed and reinjected into the reservoir.

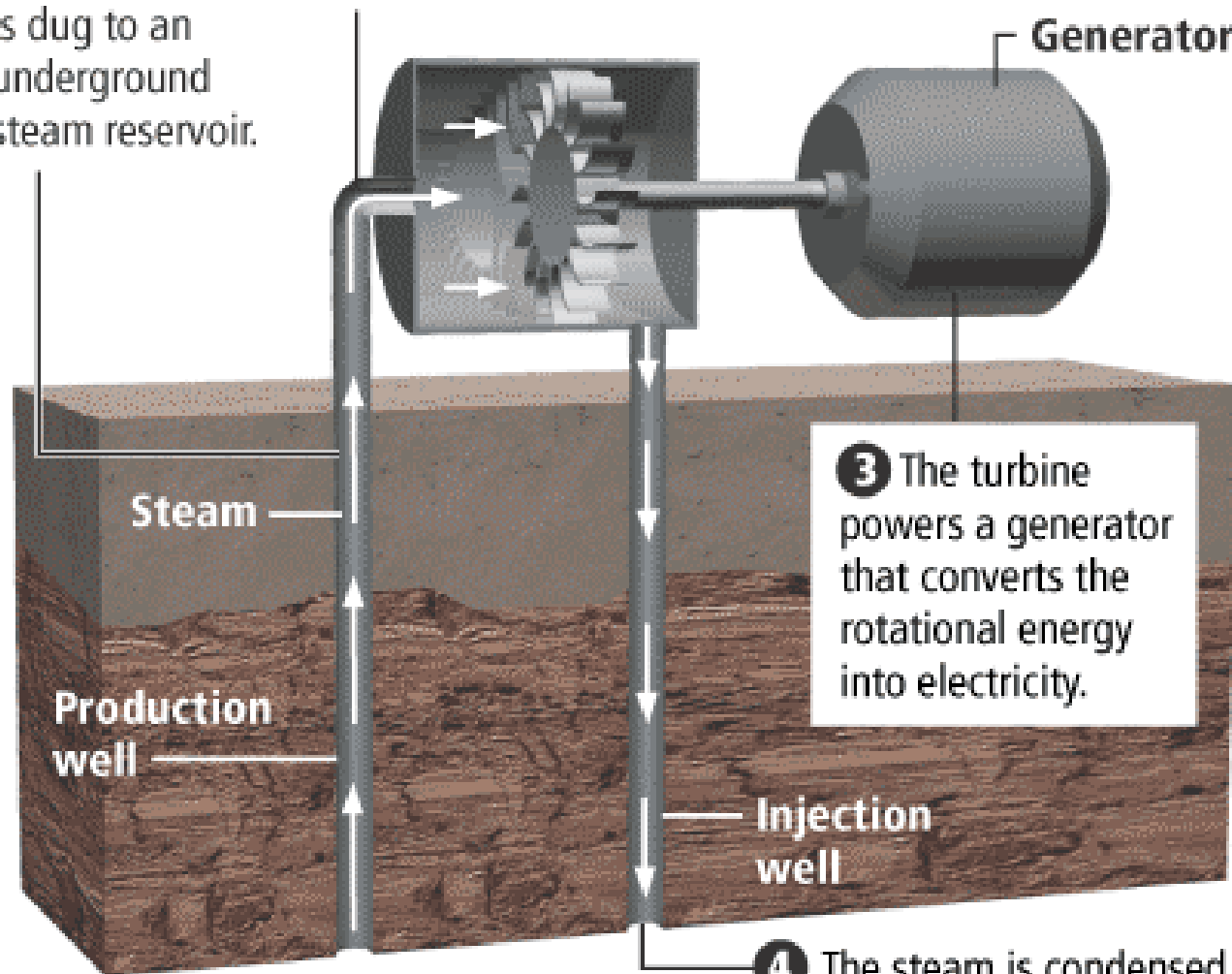

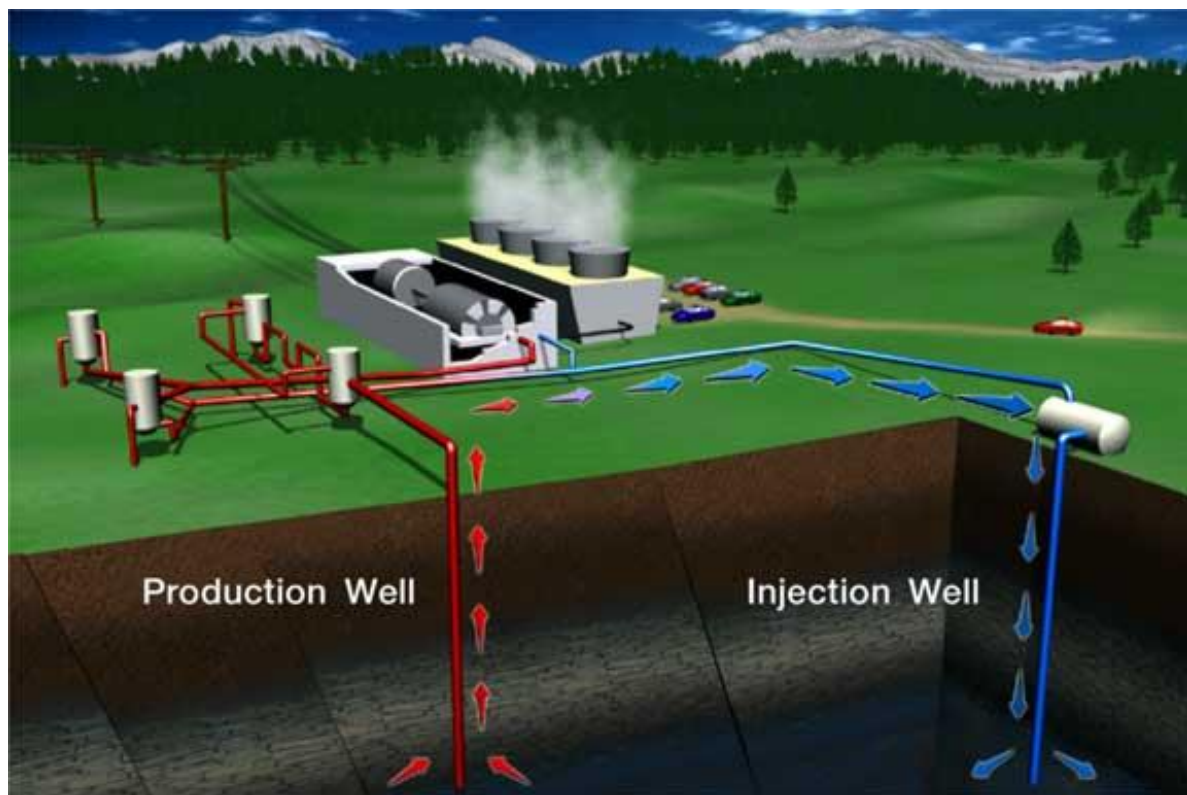

Geothermal power generation plant

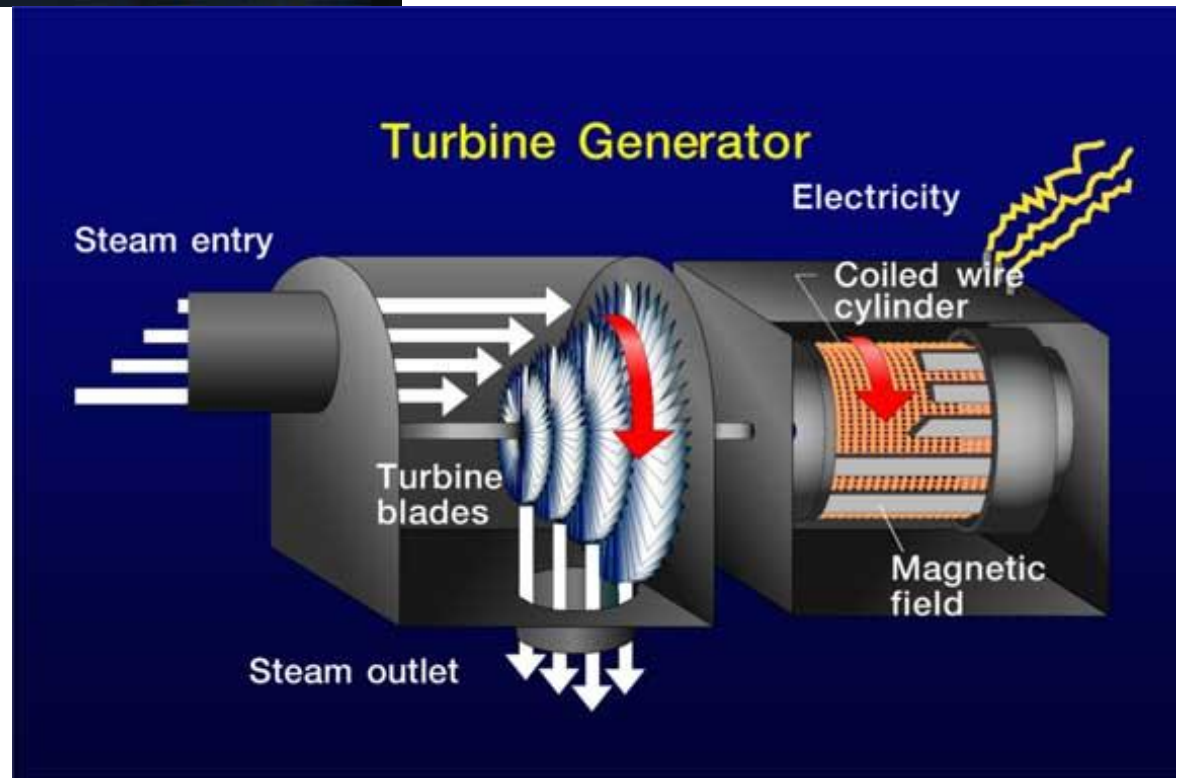

(Source: Geothermal Education Office)

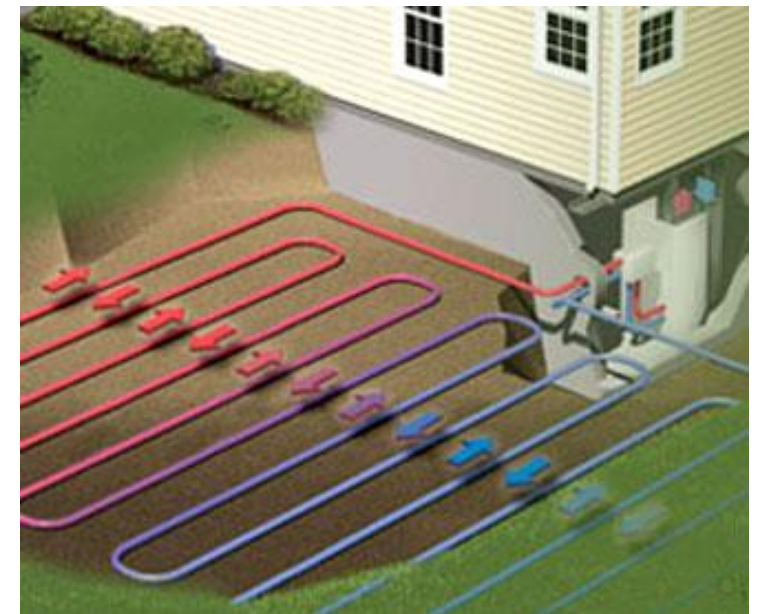
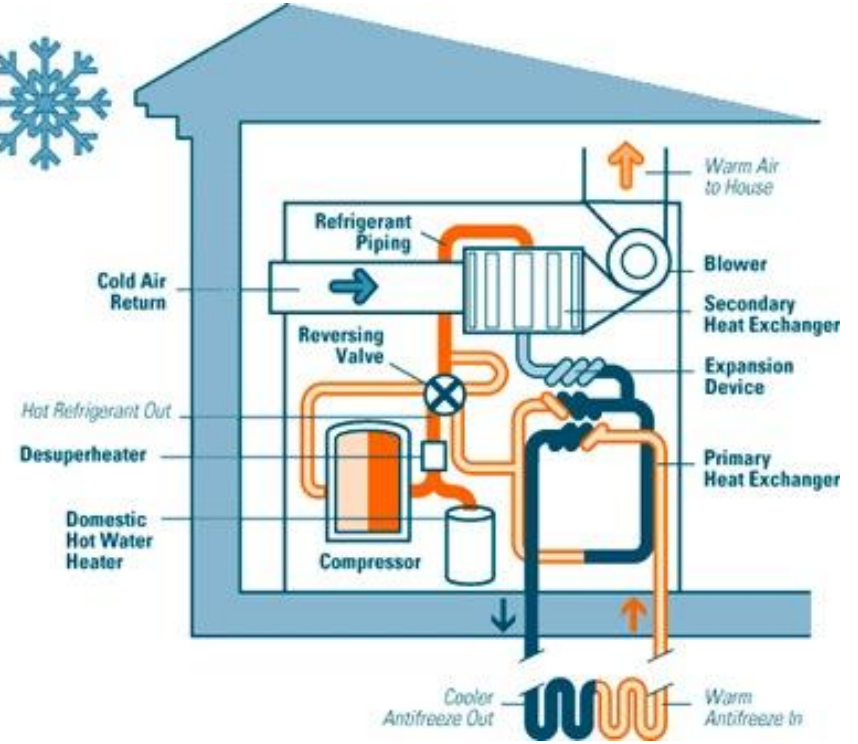
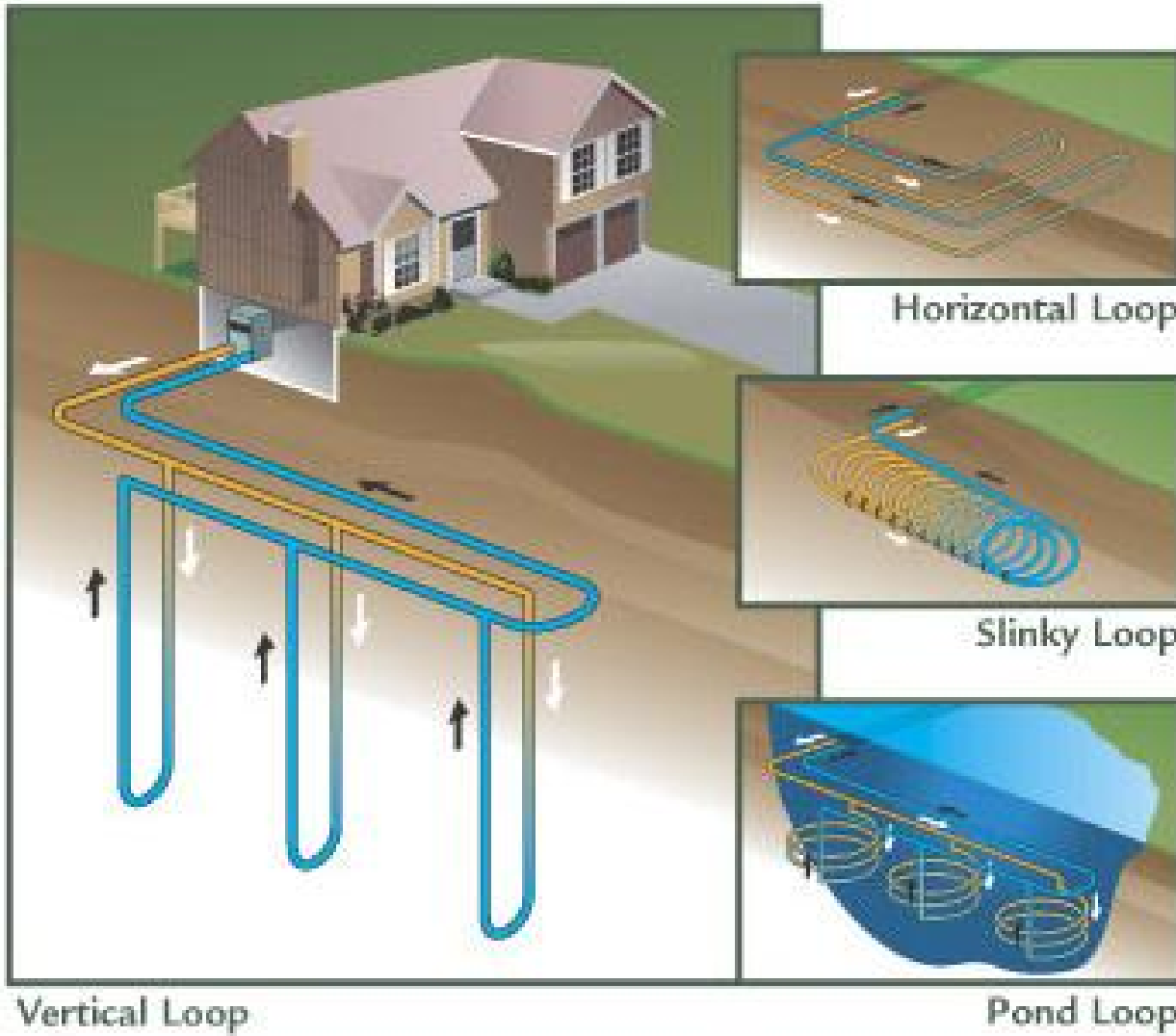

Geothermal heat pumps

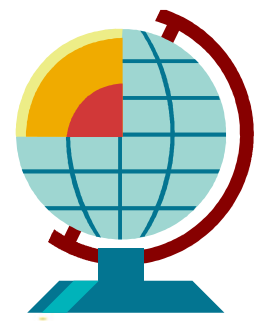

Geothermal energy

- As of 2007, geothermal plants generated 10 gigawatts of electricity (about 0.3% of global electricity demand)
- Another 28 gigawatts of direct geothermal heating capacity is installed for district heating, space heating, spas, industrial processes, desalination and agricultural applications



Small hydropower



- Hydroelectric power on a scale serving a small community or industrial plant
 - A capacity up to about 10 MW total
 - Mini hydro: < 1,000 kW
 - Micro hydro: < 100 kW
- In mountain areas or river streams
 - Common in China, Japan, USA and India
- In 2005, total world capacity is 85 gigawatts
 - The second most important RE after biomass

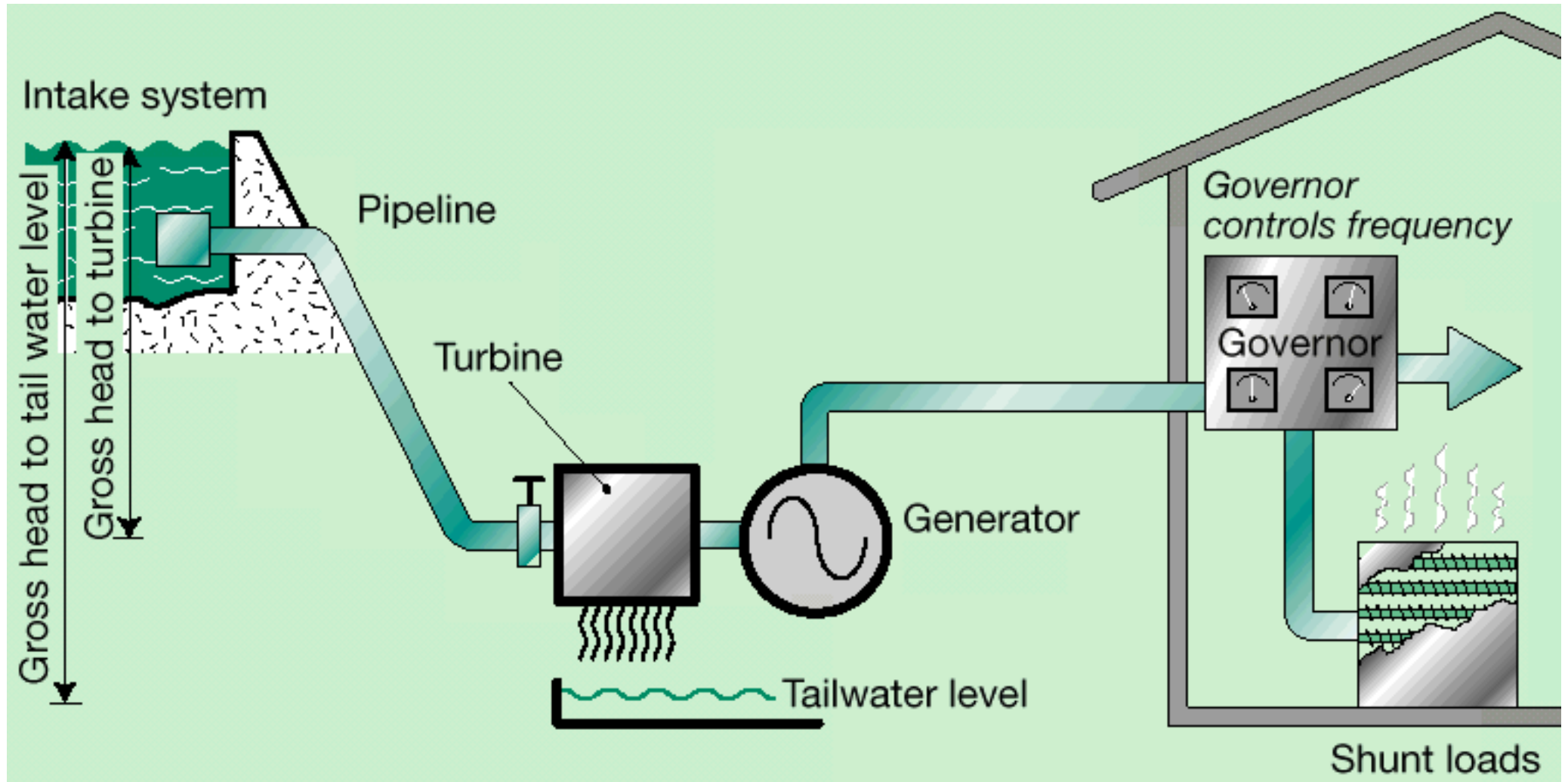

Small hydro system (example)

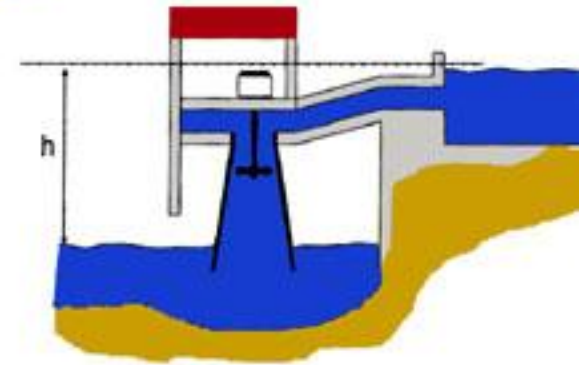
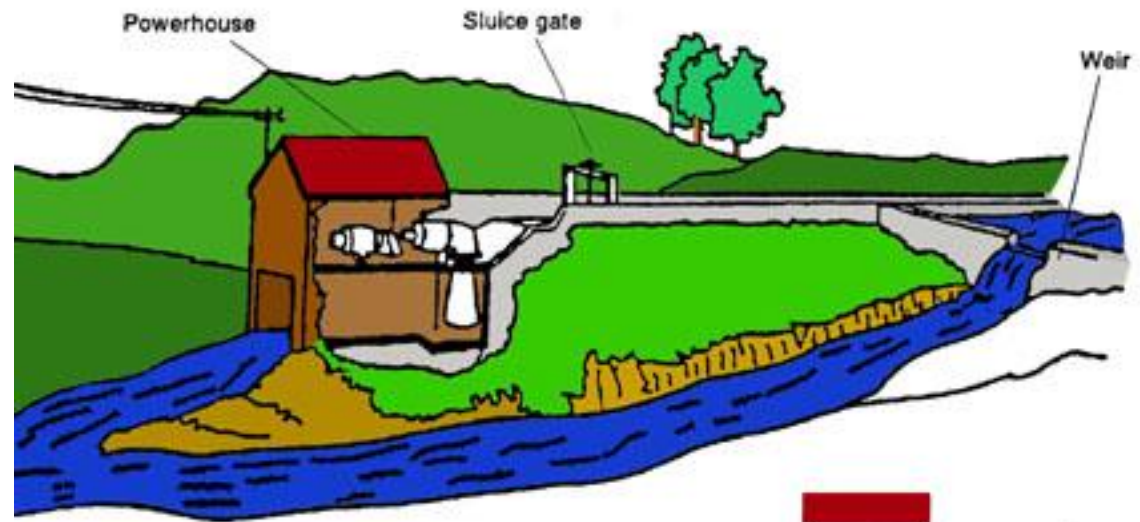

A low-head micro-hydro installation

Small hydropower



- Advantages

- Efficient energy source
- No reservoir required
- Power for developing countries
- Integrate with local power grid

- Disadvantages

- Site specific, expansion not possible
- Flows often vary considerably with the seasons
- Environmental impact (on local ecology)

Ocean energy

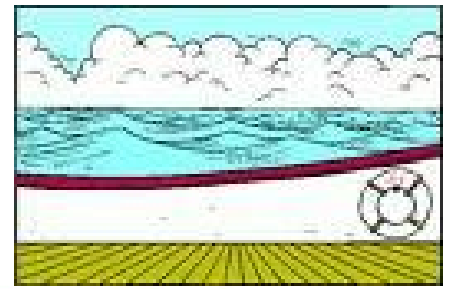

- Oceans cover $> 70\%$ of Earth's surface and are the world's largest solar collectors
- The ocean can produce two types of energy:
 - Thermal energy from the sun's heat (ocean thermal energy conversion, OTEC)
 - Mechanical energy from the tides and waves
 - A barrage (dam): convert tidal energy into electricity
 - Channel systems: funnel the waves into reservoirs
 - Float systems that drive hydraulic pumps
 - Oscillating water column systems: that use the waves to compress air within a container

Ocean thermal energy conversion (OTEC)

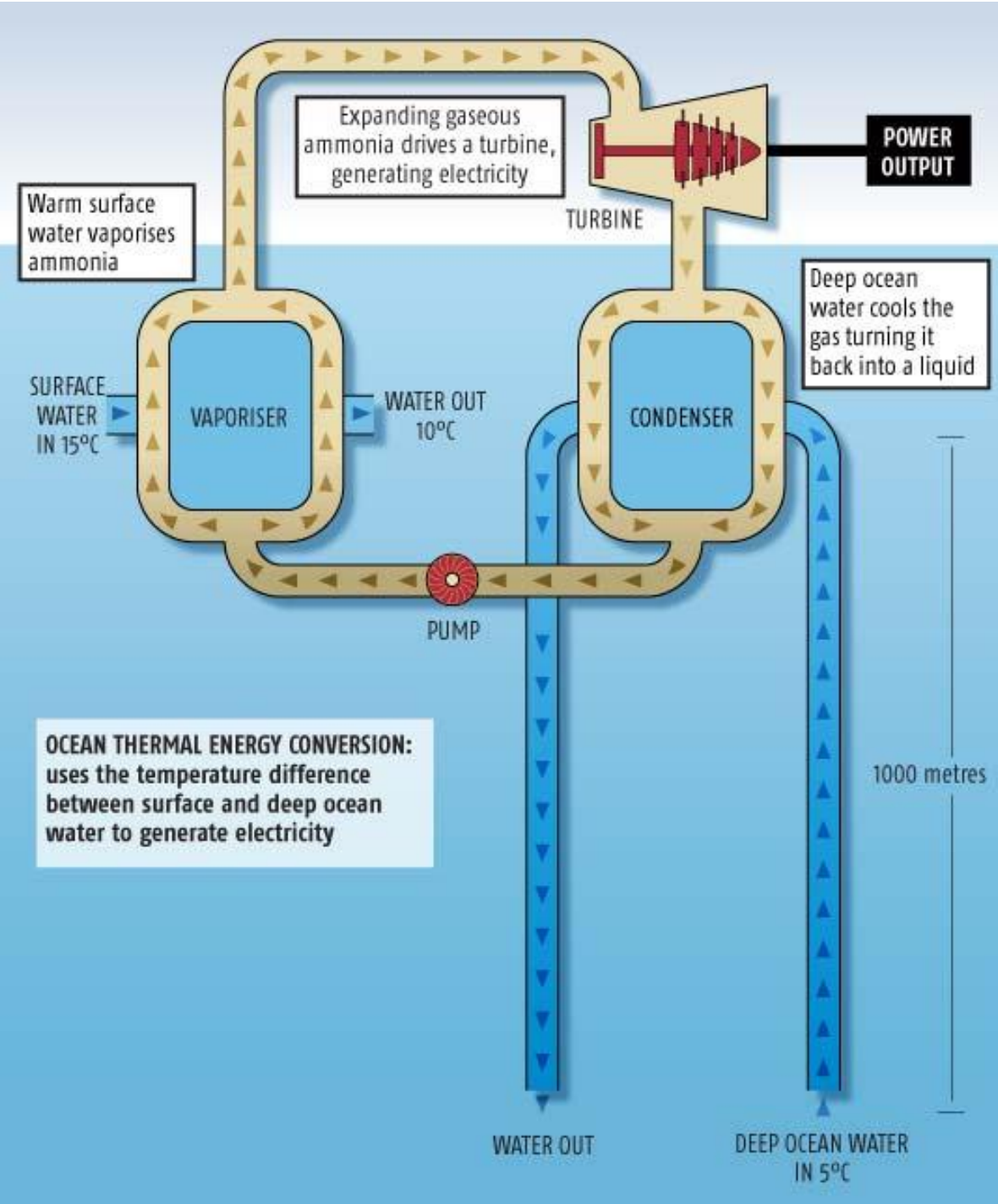
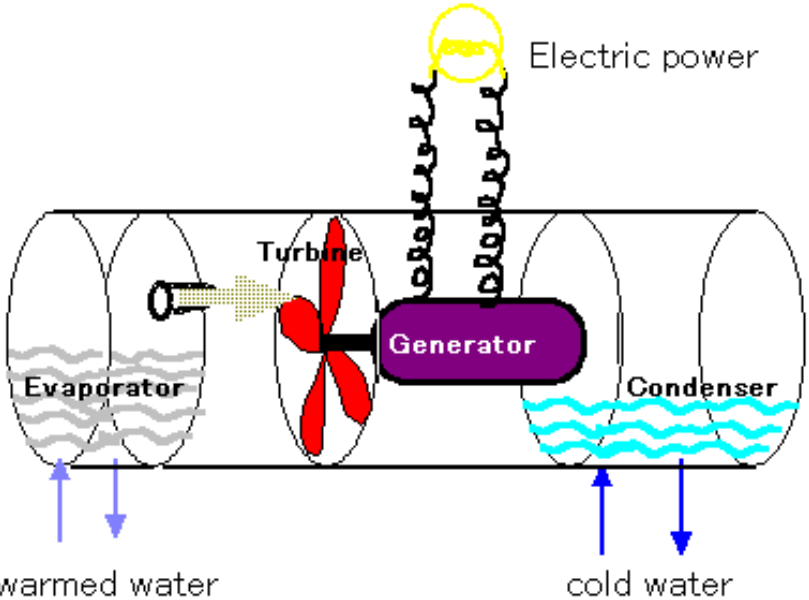

Tidal energy

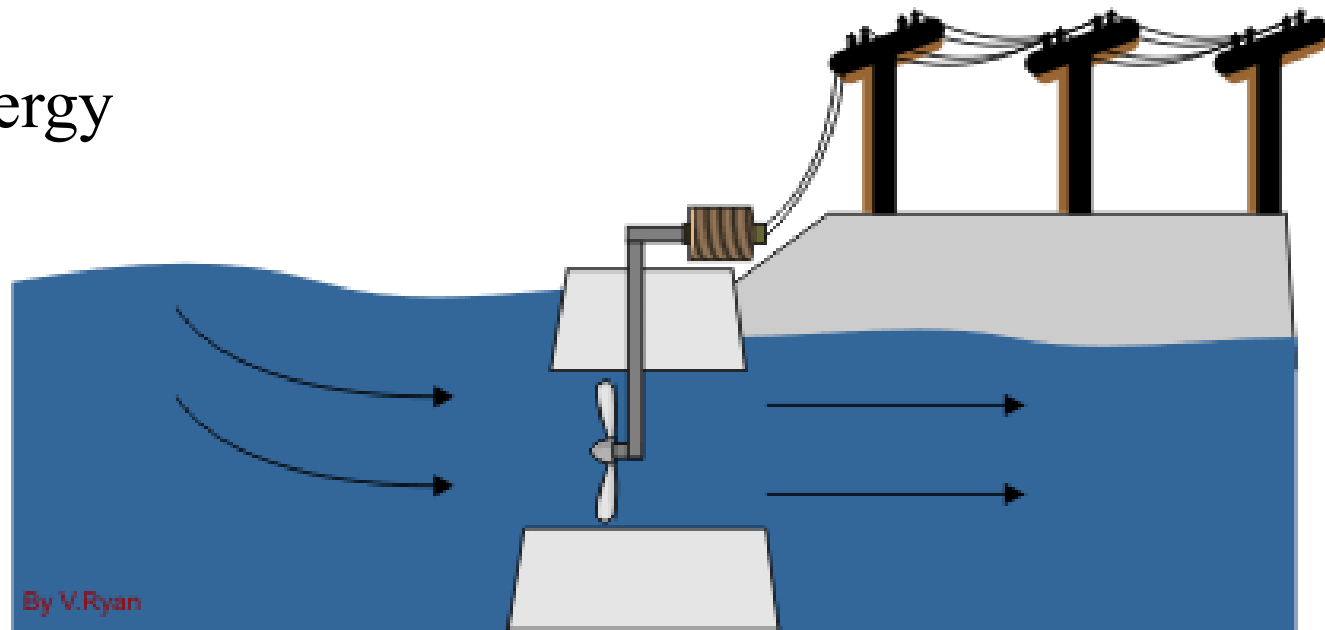

TIDE COMING IN

This tidal electricity generation works as the tide comes in and again when it goes out. The turbines are driven by the power of the sea in both directions.

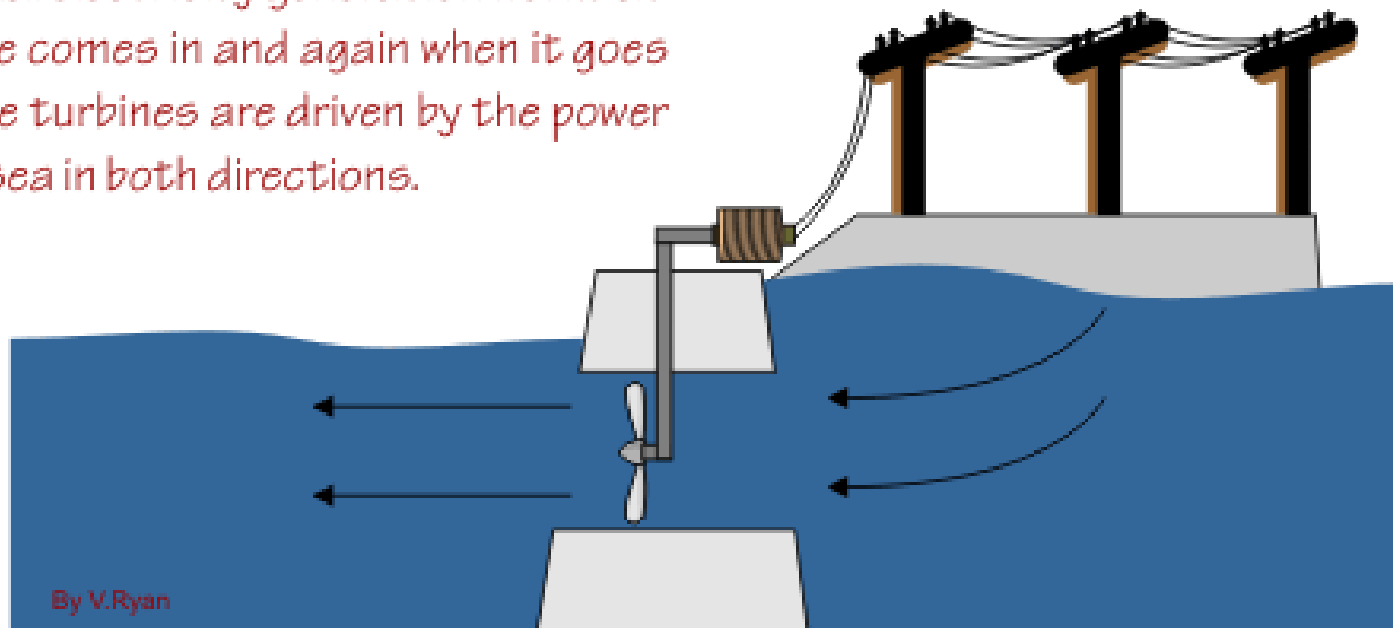

TIDE GOING OUT

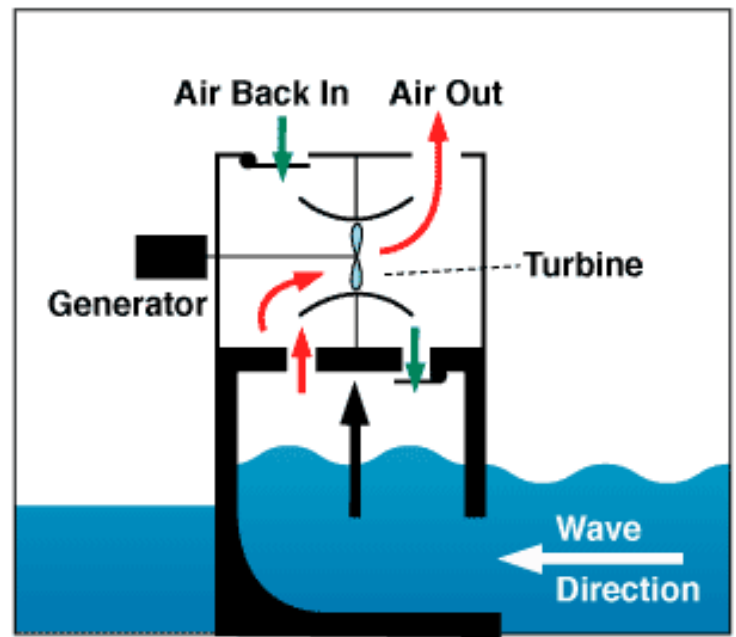
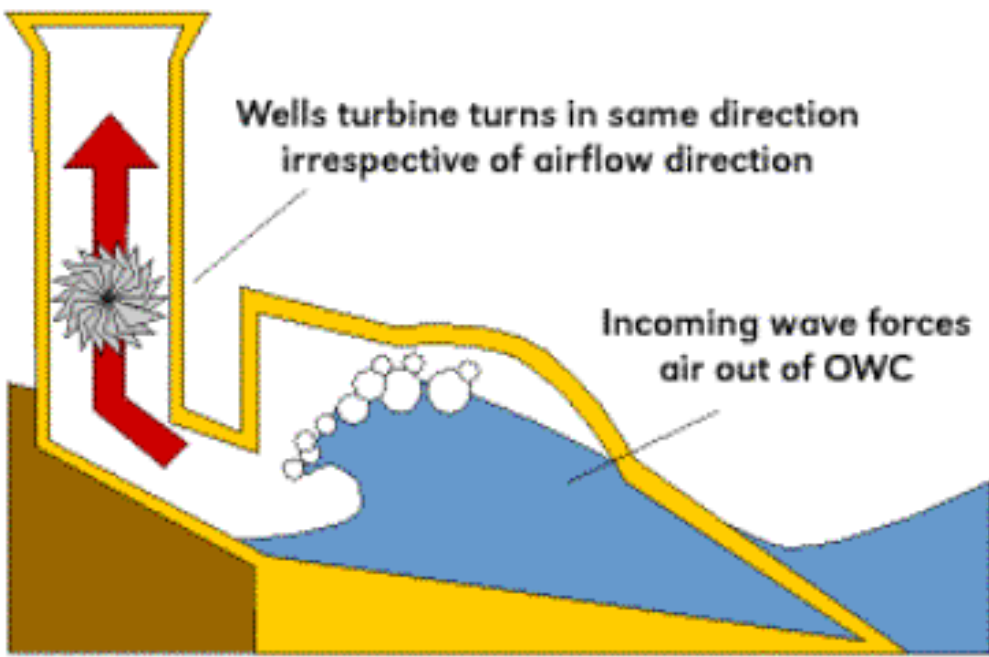

Wave energy (surface)

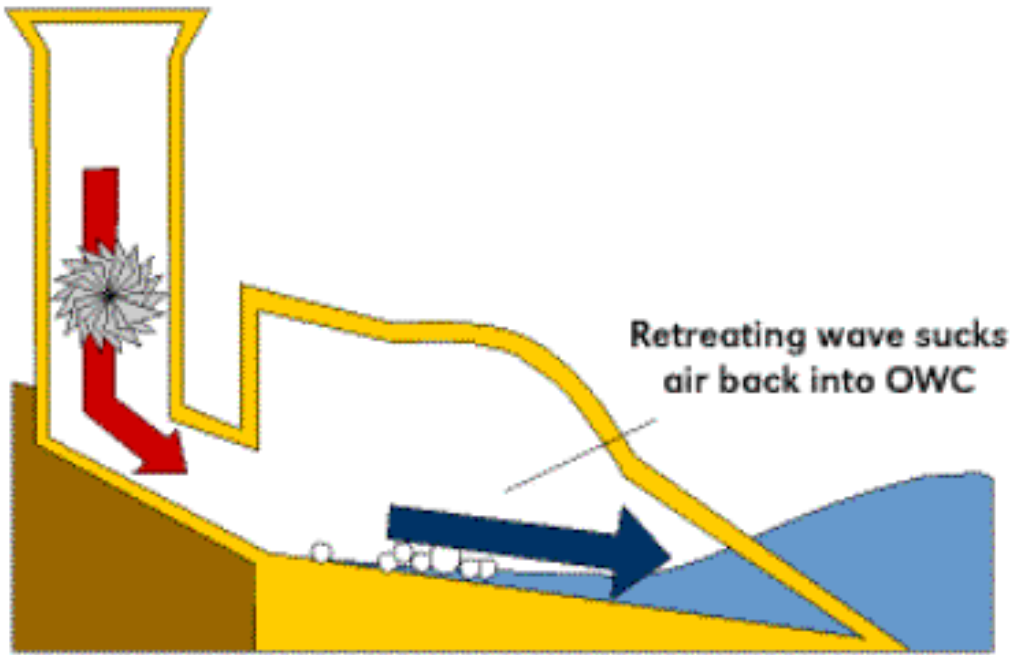

Wave terminator device

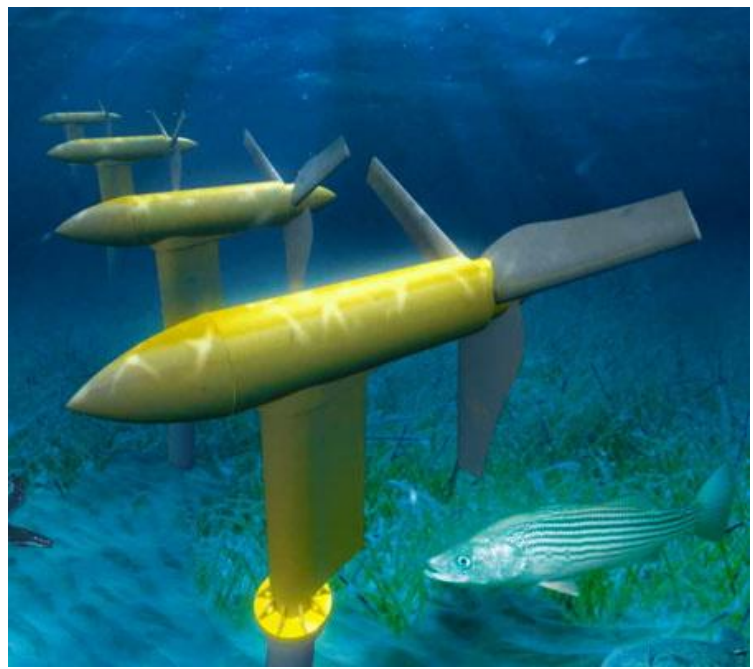

Wave current (deep sea)

(Source: www.mywindpowersystem.com)

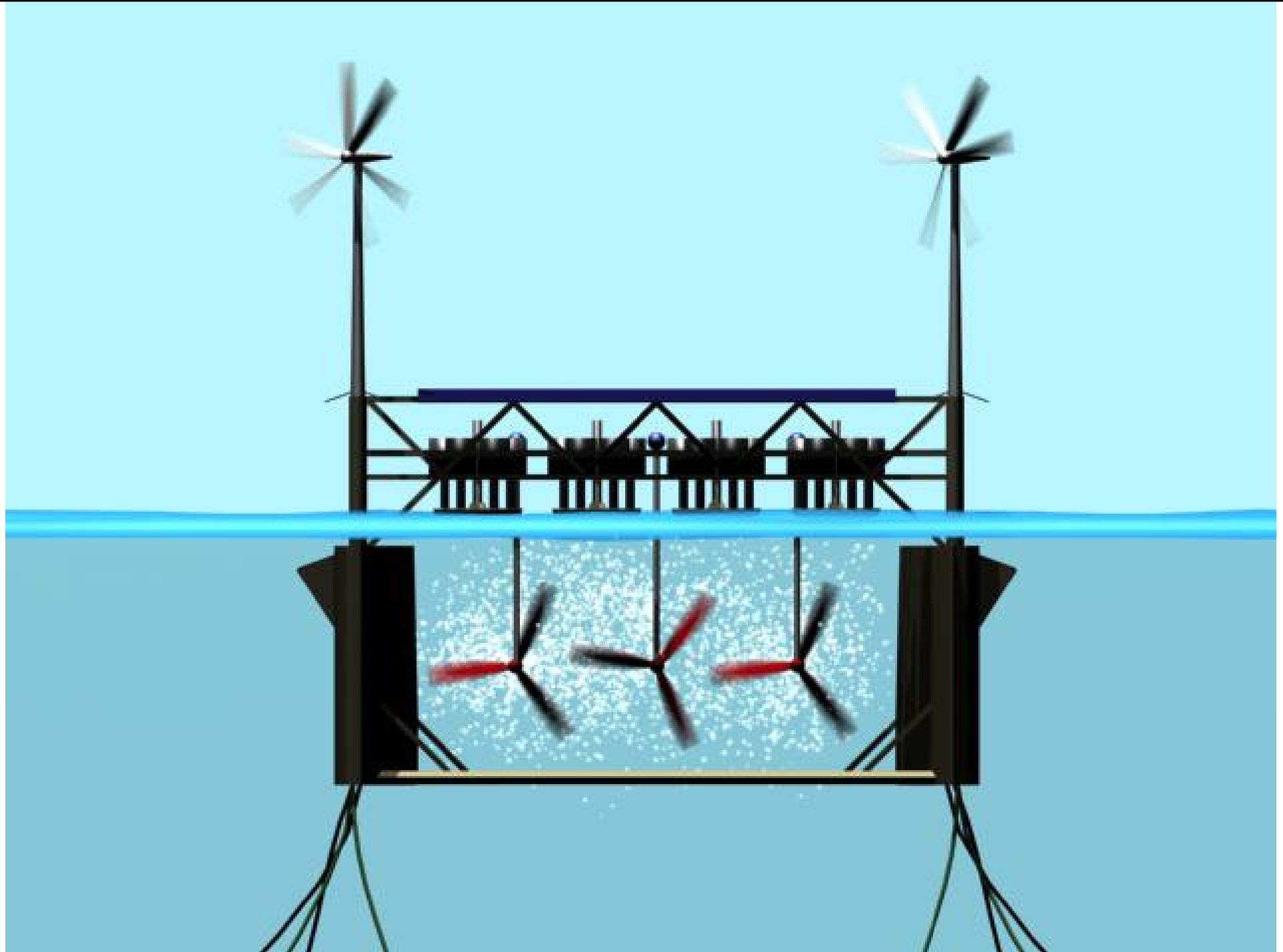

Ocean energy rig prototype (Source: www.hi-spec-uk.com)

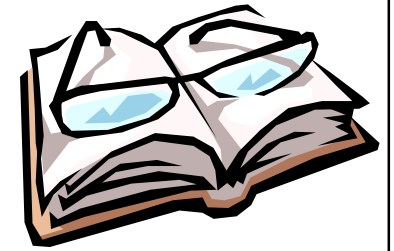

Further reading

- Public Education: Education Kit [EMSD] – Renewable Energy
 - www.emsd.gov.hk/emsd/eng/about/pe_ek.shtml
- Know more about renewable energy [EMSD]
 - http://www.emsd.gov.hk/emsd/eng/download/sgi/re_leaflet_eng.pdf
- HK RE Net
 - <http://re.emsd.gov.hk/>