

IBTM5660 Utility Services

<http://ibse.hk/IBTM5660/>



## Hot Water Supply

*Ir Dr. Sam C. M. Hui*

E-mail: [sam.cmhui@gmail.com](mailto:sam.cmhui@gmail.com)

<http://ibse.hk/cmhui/>

Jan 2023

# Contents



- System selection
- Gas & electric water heaters
- Solar hot water & heat pumps
- Centralised hot water systems
- Design practice in Hong Kong



# An example of cold and hot water supply system

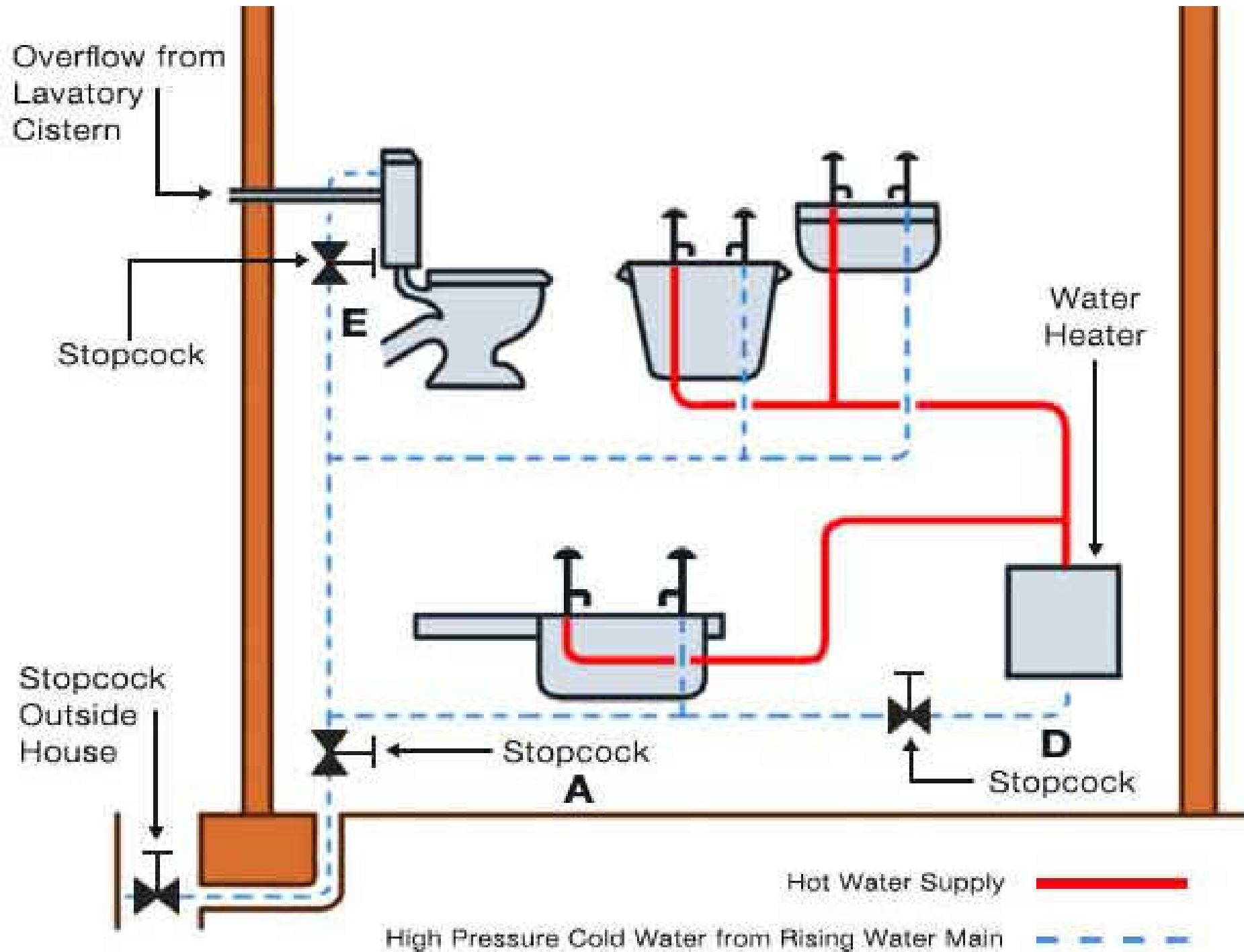

# System selection



- Design of a hot water system:
  - Determine the demand of hot water - quantity and temperature
  - Selecting the type, capacity and heating surface of the calorifier - or heat exchanger
  - Selecting the water heater or boiler
  - Design pipe scheme and size pipes
- Domestic hot water (DHW)
  - Supply to taps & appliances



# System selection



- Key factors to consider:
  - Quantity of hot water required
  - Temperature in storage & at outlets (55-65 °C)
  - Cost of installation & maintenance
  - Fuel energy requirements & running costs
  - Conservation of water & energy
  - Safety (explosion hazard, thermal burns, bacteria)
- Hot water supply may be combined with central heating systems (to radiators)

# System selection



- System types:
  - Central & local
  - Gas-fired & electric
  - Single point & multi-point
  - Vented & unvented
  - Direct & indirect
- Types of water heaters:
  - Instantaneous type (tankless)
  - Storage type
  - High pressure (larger storage)

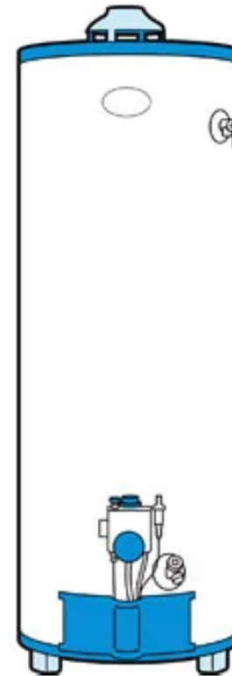

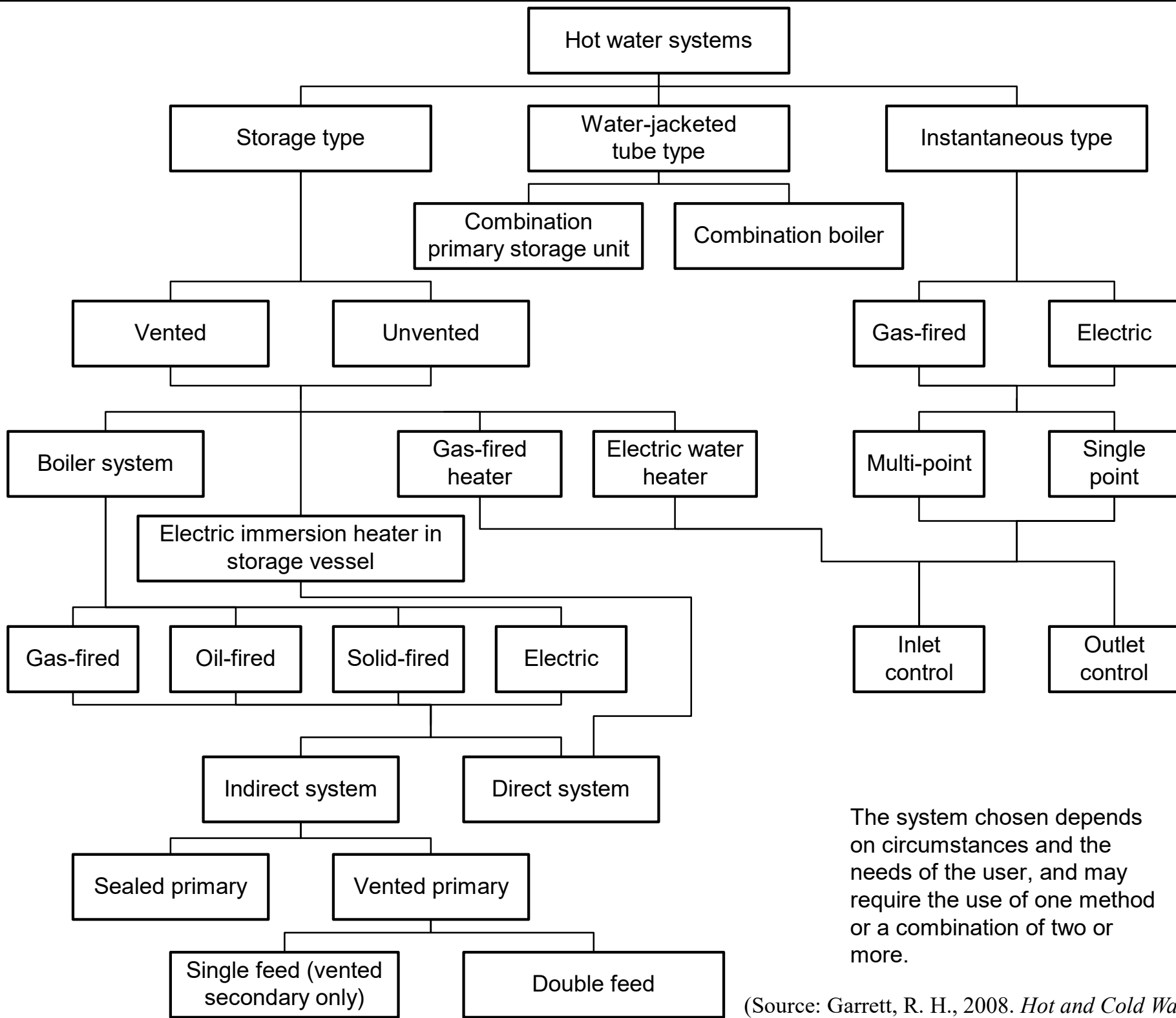

The system chosen depends on circumstances and the needs of the user, and may require the use of one method or a combination of two or more.

(Source: Garrett, R. H., 2008. *Hot and Cold Water Supply*)

# System selection



- Consider instantaneous water heaters

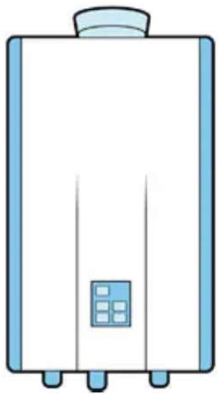

- Adequate gas or electricity supplies
- Where constant flow temp. is important, the heater should be fitted with a water governor at its inflow
  - Close control of temperature for showers
- Variations in pressure can cause flow and temperature problems
- Multi-point heaters for showers should be avoided
- Room-sealed types are preferred for gas-fired
- Electric heaters must comply safety regulations



# How Does a Tankless Water Heater Work?

## *The Process:*

1. A hot water tap is turned on.
2. Water enters the heater.
3. The water flow sensor detects the water flow.
4. The computer automatically ignites the burner.
5. Water circulates through the heat exchanger.
6. The heat exchanger heats the water to the designated temperature.
7. When the tap is turned off, the unit shuts down.

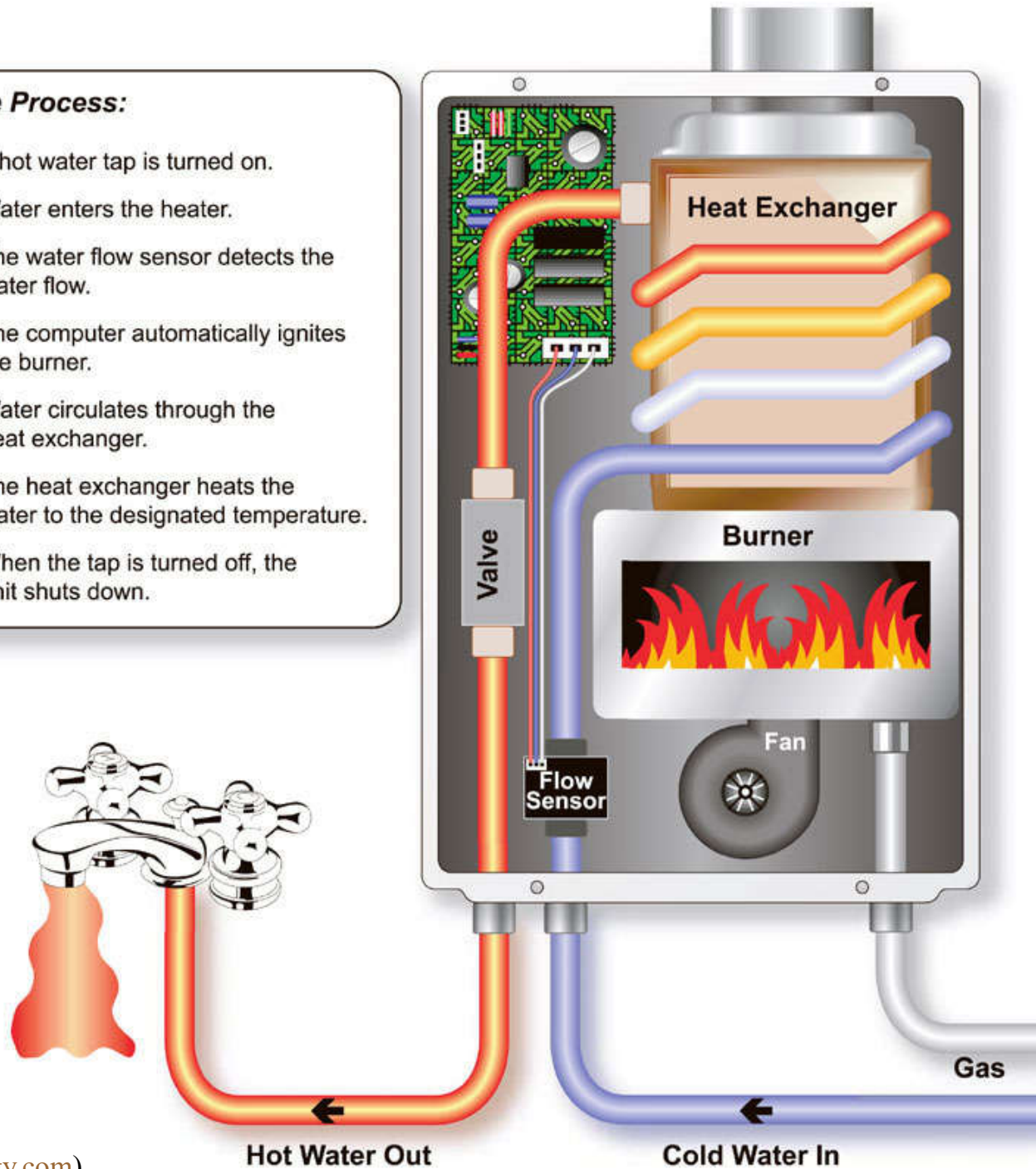

# Gas hot water heaters components (with storage)

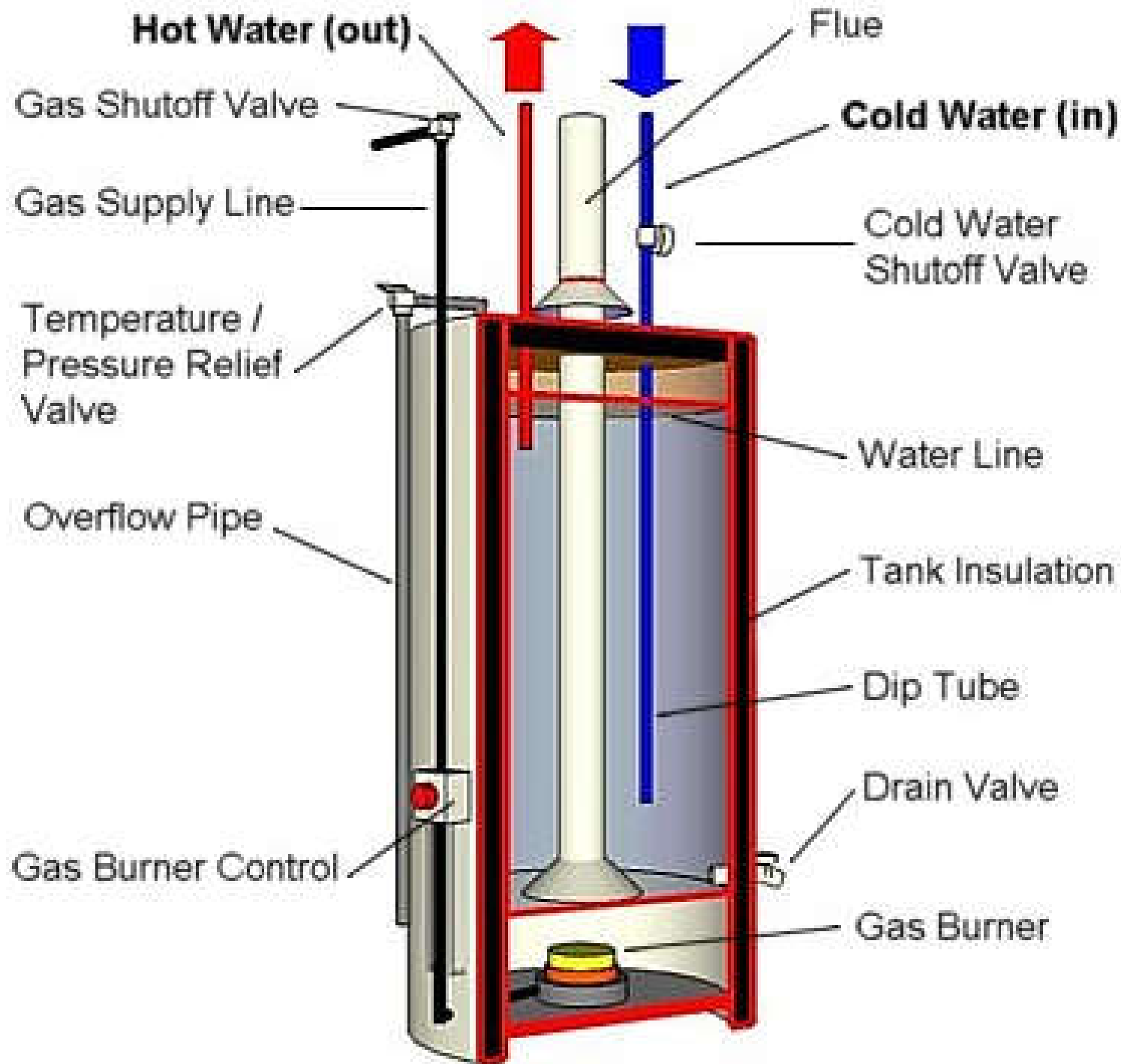

# System selection



- Common types of water heaters
  - Gas-fired water heaters
  - Electric water heaters
  - Water-jacketed tube heaters
  - Solar water heating
  - Heat pump water heaters



# Gas & electric water heaters



- Gas-fired water heaters

- Three types:

- Instantaneous
- Storage
- Circulatory

- With conventional or balanced flue

- Pilot flame lights the burner

- The heater may be supplied direct from the main or a cold water storage tank

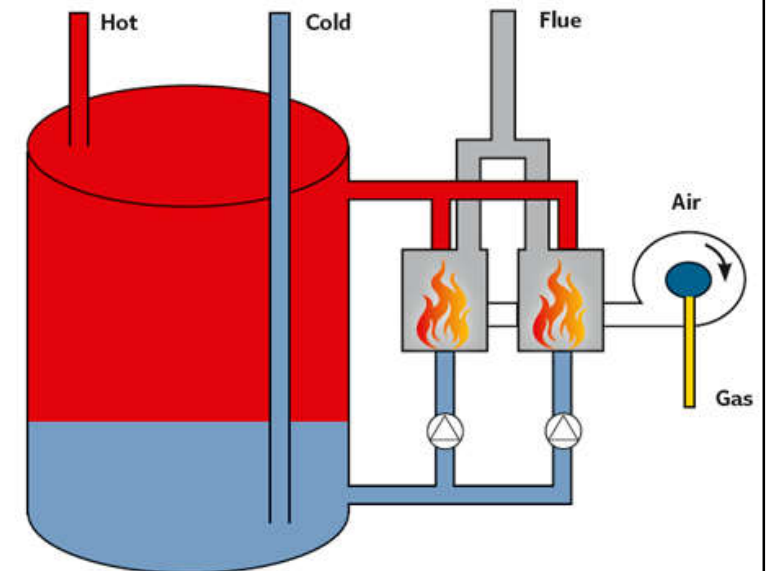

# Gas-fired instantaneous water heaters

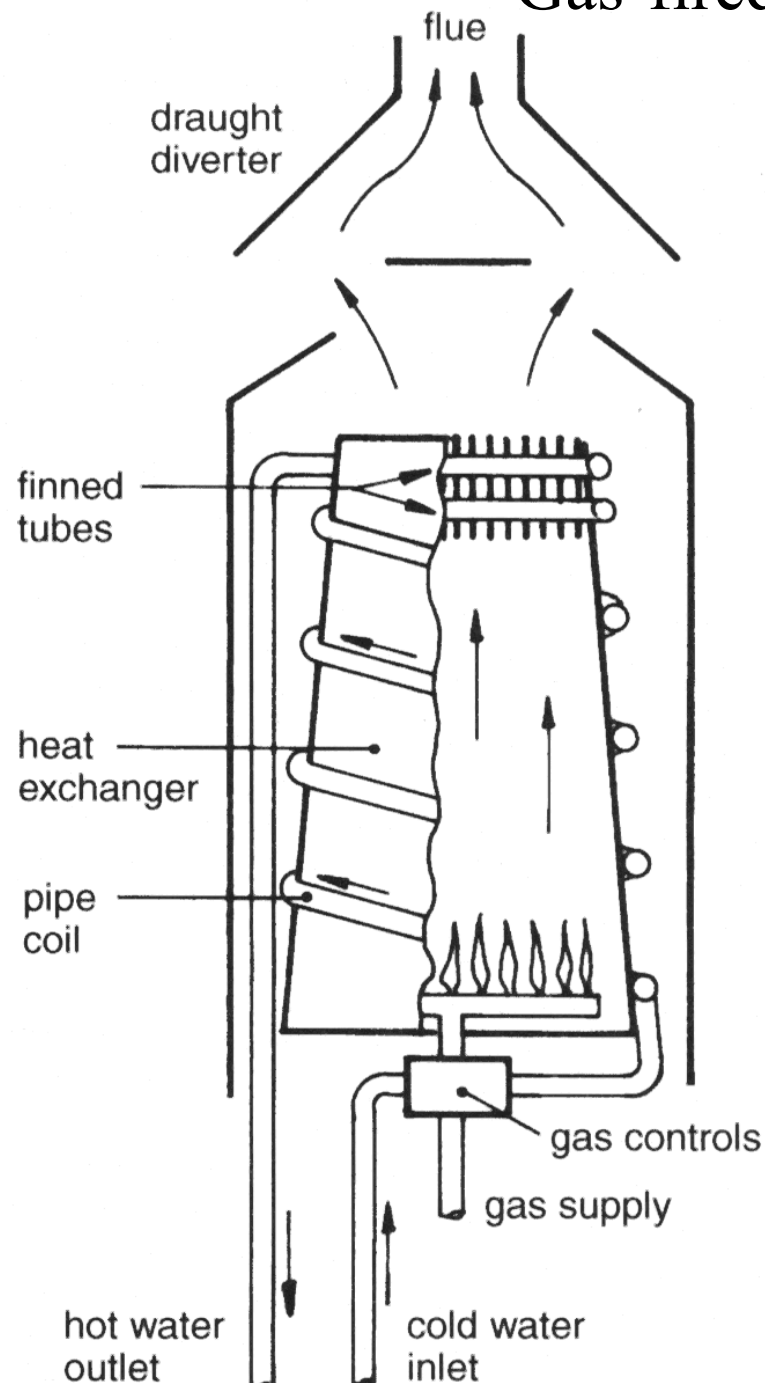

**With conventional flue**

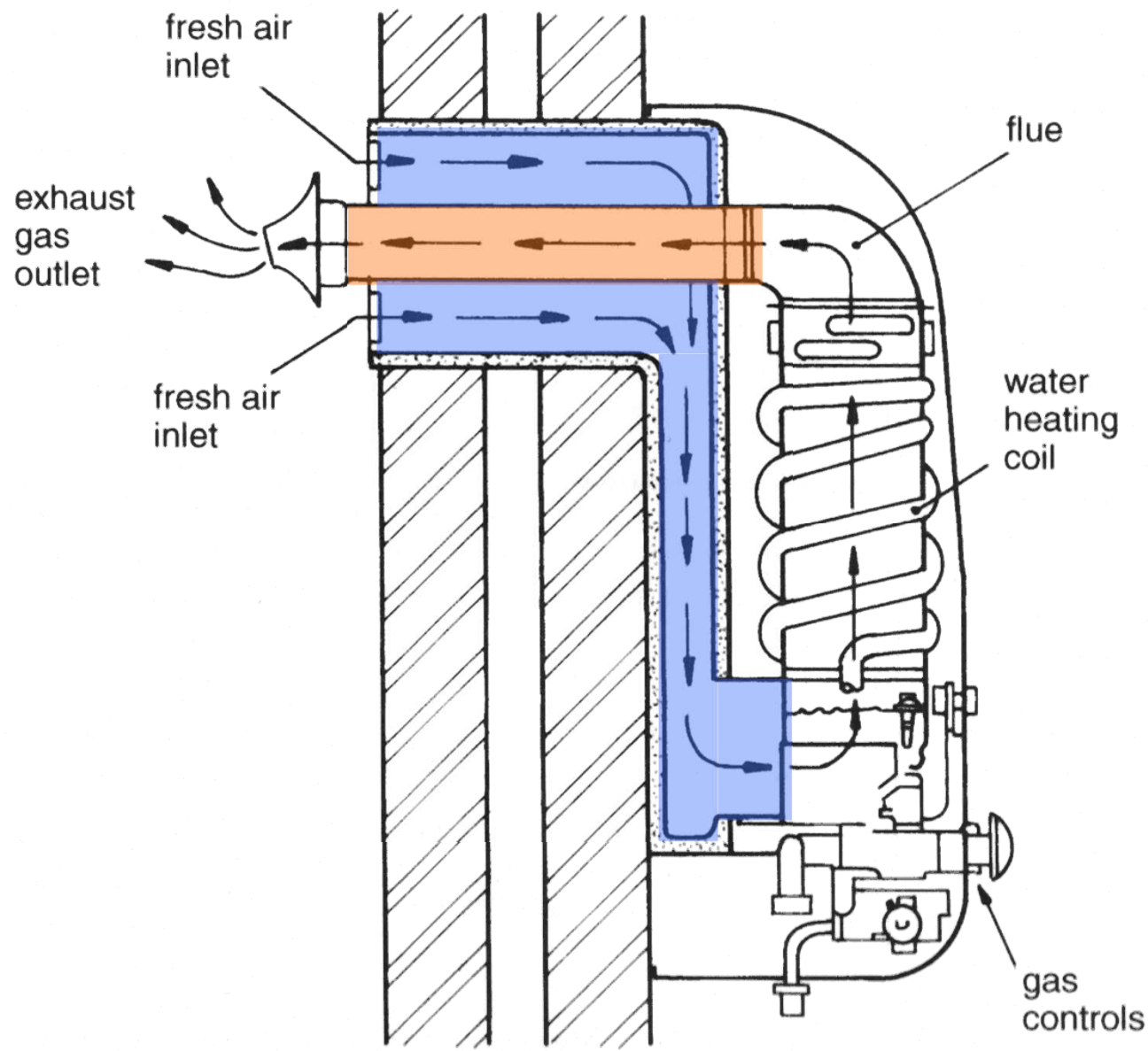

**With balanced flue**

(Source: Garrett, R. H., 2008. *Hot and Cold Water Supply*)

## 禁止使用無煙道式氣體熱水爐 以供浴室或淋浴使用

Prohibition of Flueless Gas Water Heaters  
Used to Serve a Bathroom or Shower



機電工程署  
Electrical & Mechanical  
Services Department

### 1. 不合規格的無煙道式氣體熱水爐 裝置

#### Substandard Flueless Gas Water Heater Installations

無煙道式氣體熱水爐供浴室或淋浴用途屬於危險的裝置，因為該熱水爐會從室內抽取供燃燒用之空氣，而燃燒後之廢氣(包括有毒的一氧化碳)會直接帶進裝有這類熱水爐的房間內，如在通風不足下可能積聚至危險水平。

Flueless gas water heaters serving bathrooms or showers are considered dangerous because they consume the air inside the room and the products of combustion containing toxic carbon monoxide discharge directly into the room where the heater is situated, and may build up to dangerous levels if ventilation is inadequate.

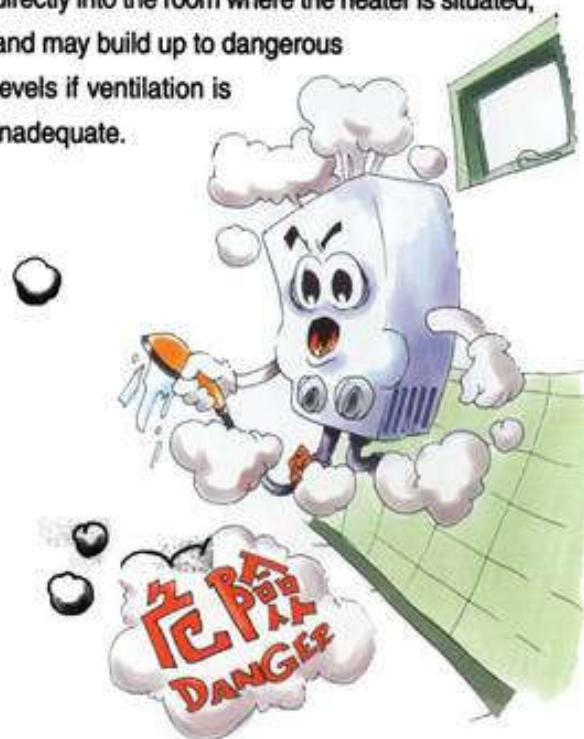

### 2. 禁止使用無煙道式氣體熱水爐以供 浴室或淋浴用途

#### Prohibit Use of Flueless Gas Water Heaters Supplying Bathroom or Shower

為防止不適當使用無煙道式氣體熱水爐而引致危險，立法局於1999年11月通過氣體安全規例修訂，禁止使用無煙道式氣體熱水爐以供浴室或淋浴用途。該項修訂將於**2000年4月1日**正式實施。此外，新規例亦禁止任何人供應或安裝新的無煙道式熱水爐，或以其他無煙道式型號替換現時無煙道式氣體熱水爐。

In order to eliminate dangers from improper use of flueless gas water heaters, LEGCO passed an Amendment of the Gas Safety Regulations in November 1999, which prohibits the use of a flueless gas water heater to serve a bathroom or shower. The Amendment will come into effect on **1 April 2000**. In addition, the new law also prohibits anyone from supplying or installing a new flueless gas water heater or replacing an existing flueless gas water heater by another flueless model.

### 3. 氣體安全規例修訂內容 Details of Amendment to Gas Safety Regulations

修訂主要分為二部份，第一，〈氣體安全(裝置及使用)規例〉修訂確立自**2000年7月1日**開始任何人不得將無煙道式氣體熱水爐供浴室或淋浴間使用。

## Acceptable Locations of Room-Sealed Gas Water Heater Terminals

### EXTERNAL VIEW

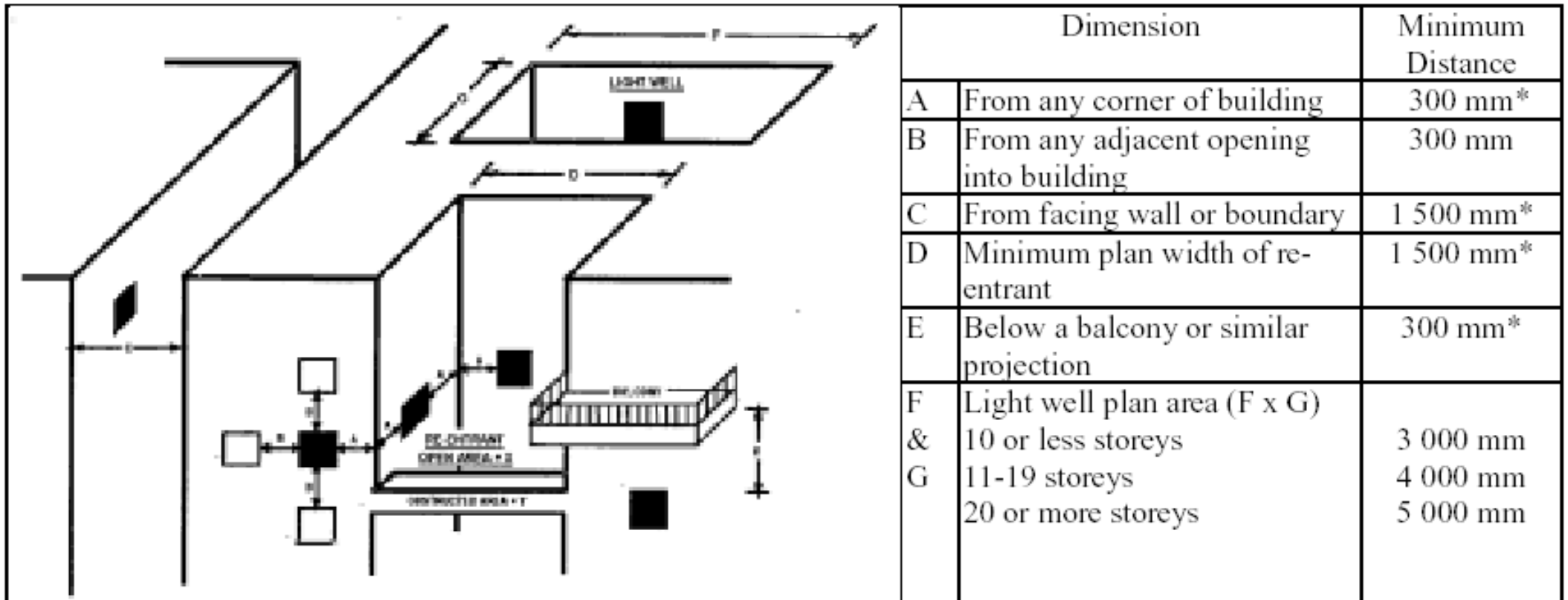

\* May be reduced for fanned draught models.  
See manufacturer's instructions.

Why we need to consider  
acceptable locations for the  
gas water heaters?

# Gas & electric water heaters



- Gas-fired instantaneous water heaters

- Directly supplied heater

- Constant flow rate needed to maintain 55 °C temp. difference between feed water & heated water
- Pressure & flow variations will affect temp. at outlets
- Use only thermostatically controlled shower mixer

- Indirectly supplied heater

- High installation cost compared with mains-fed system
- Constant pressure from storage for shower & other fittings give more stable temp. control



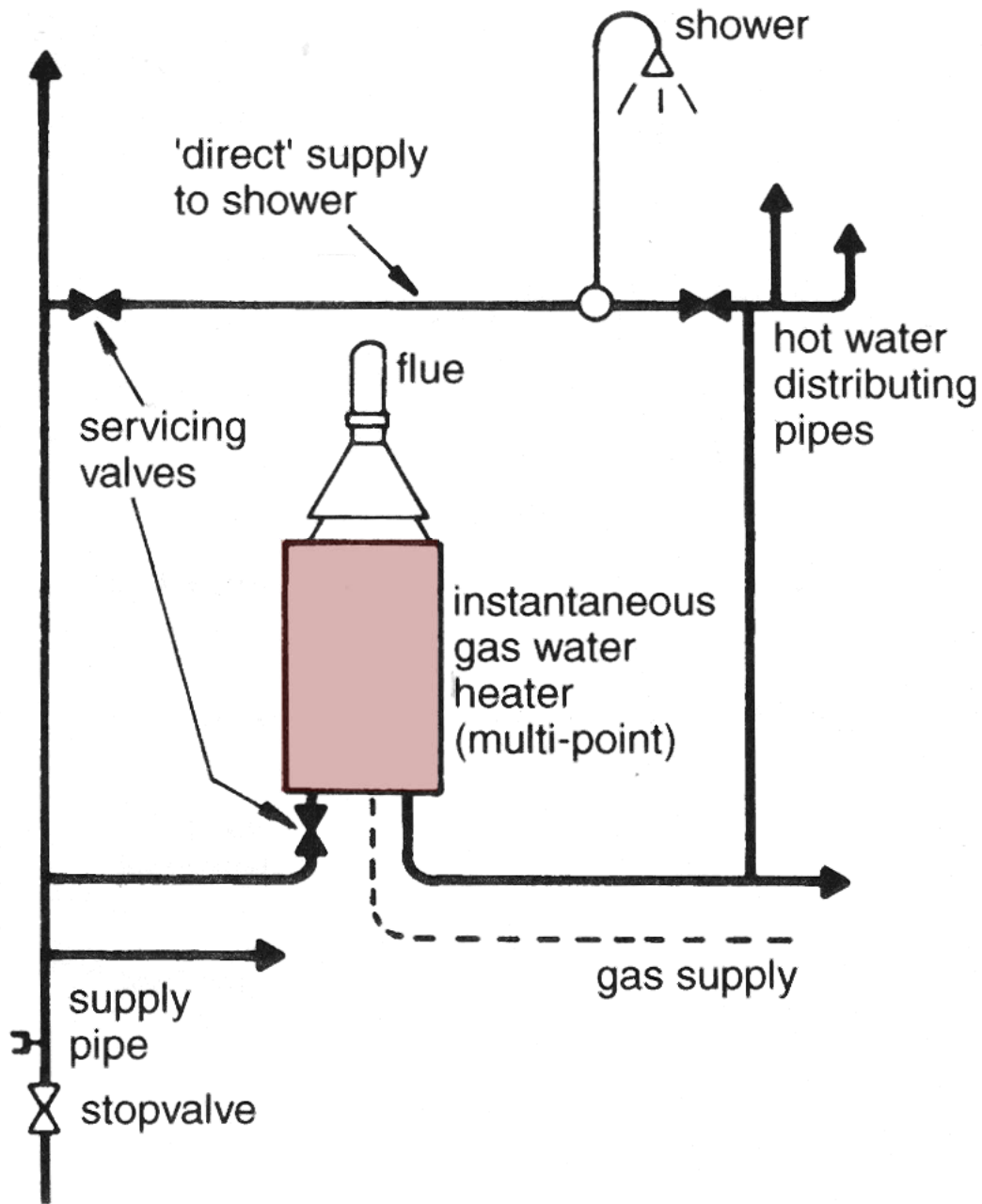

Directly supplied heater

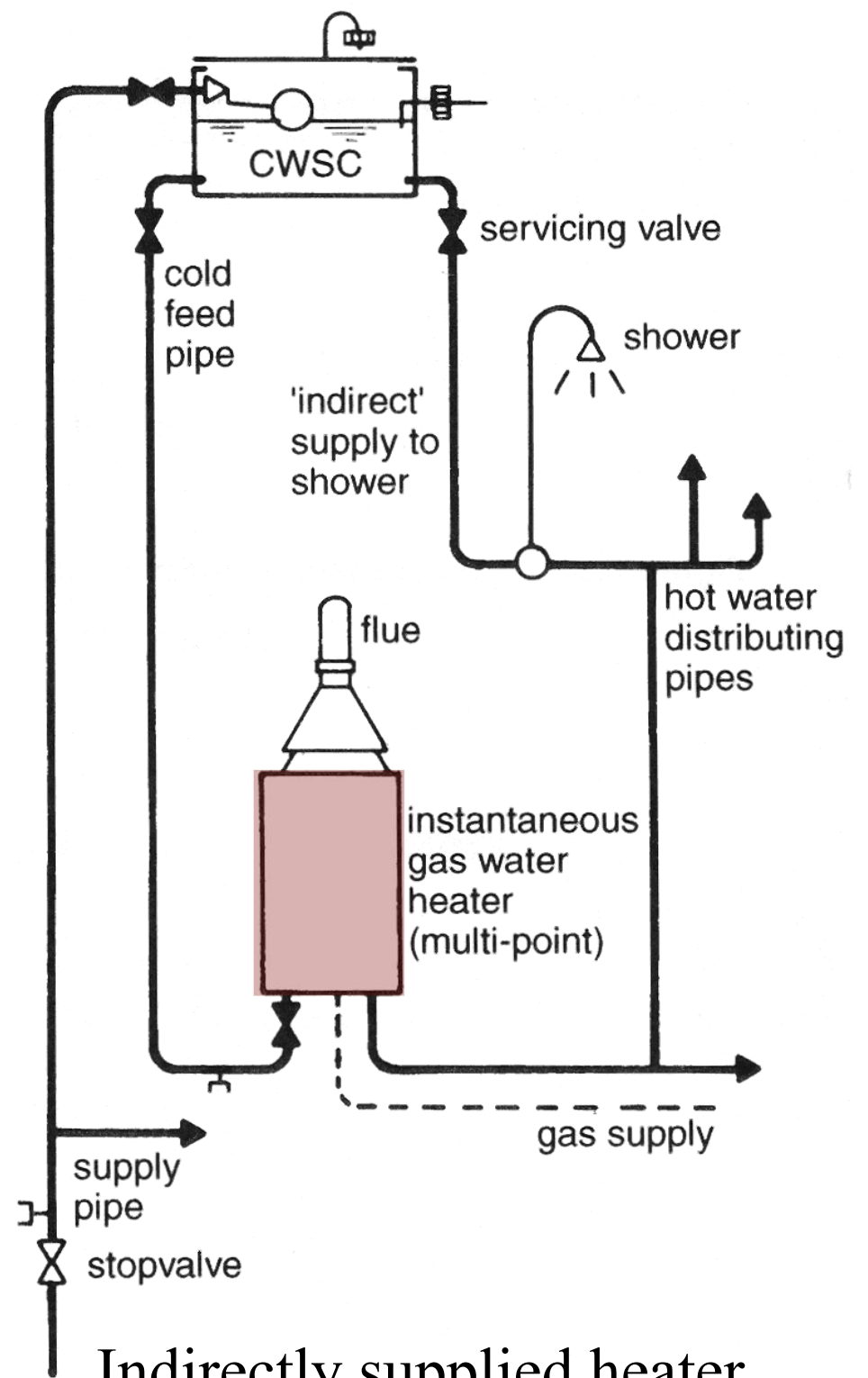

Indirectly supplied heater

# Installation of gas circulator

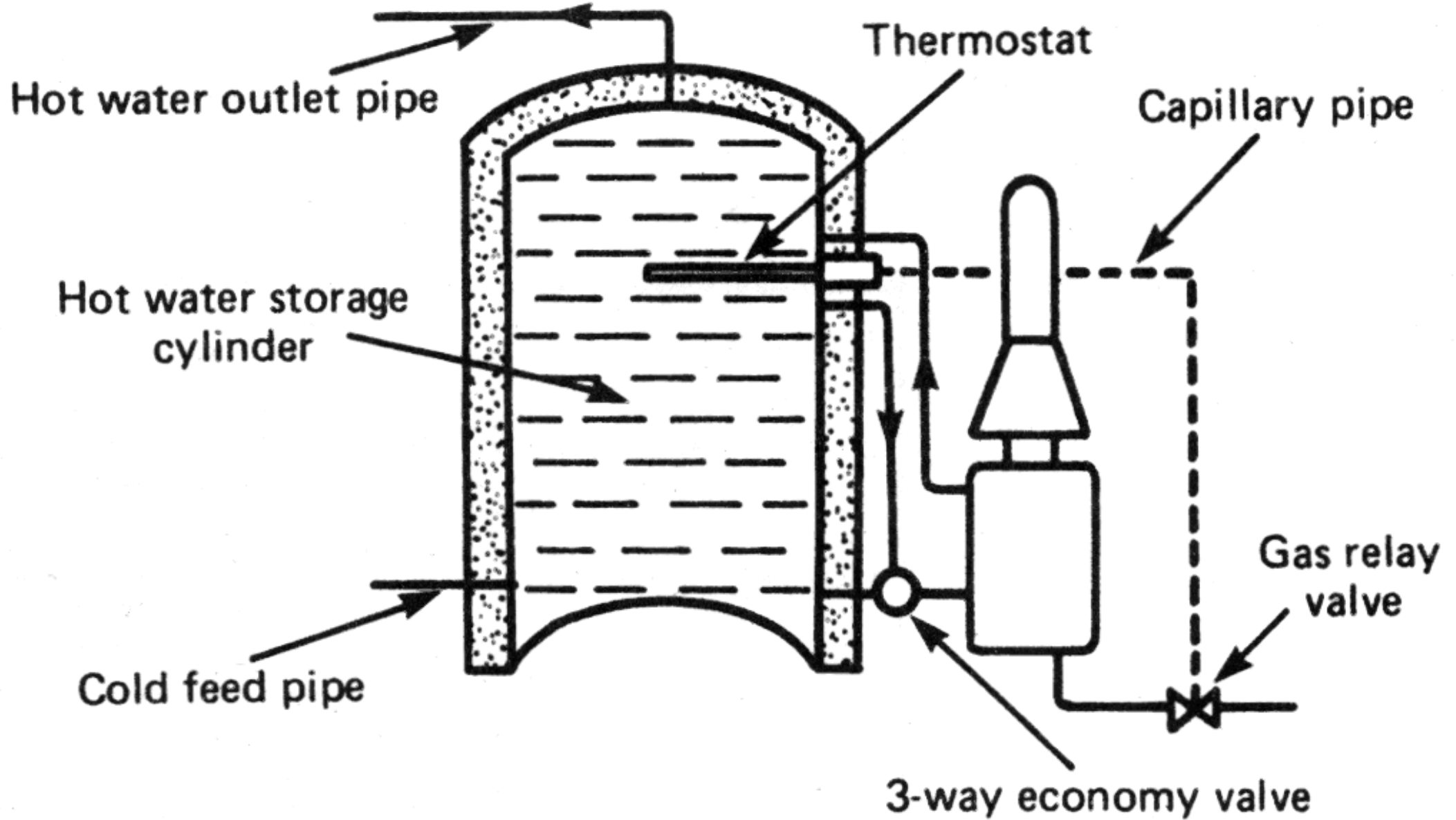

# Storage type gas water heater

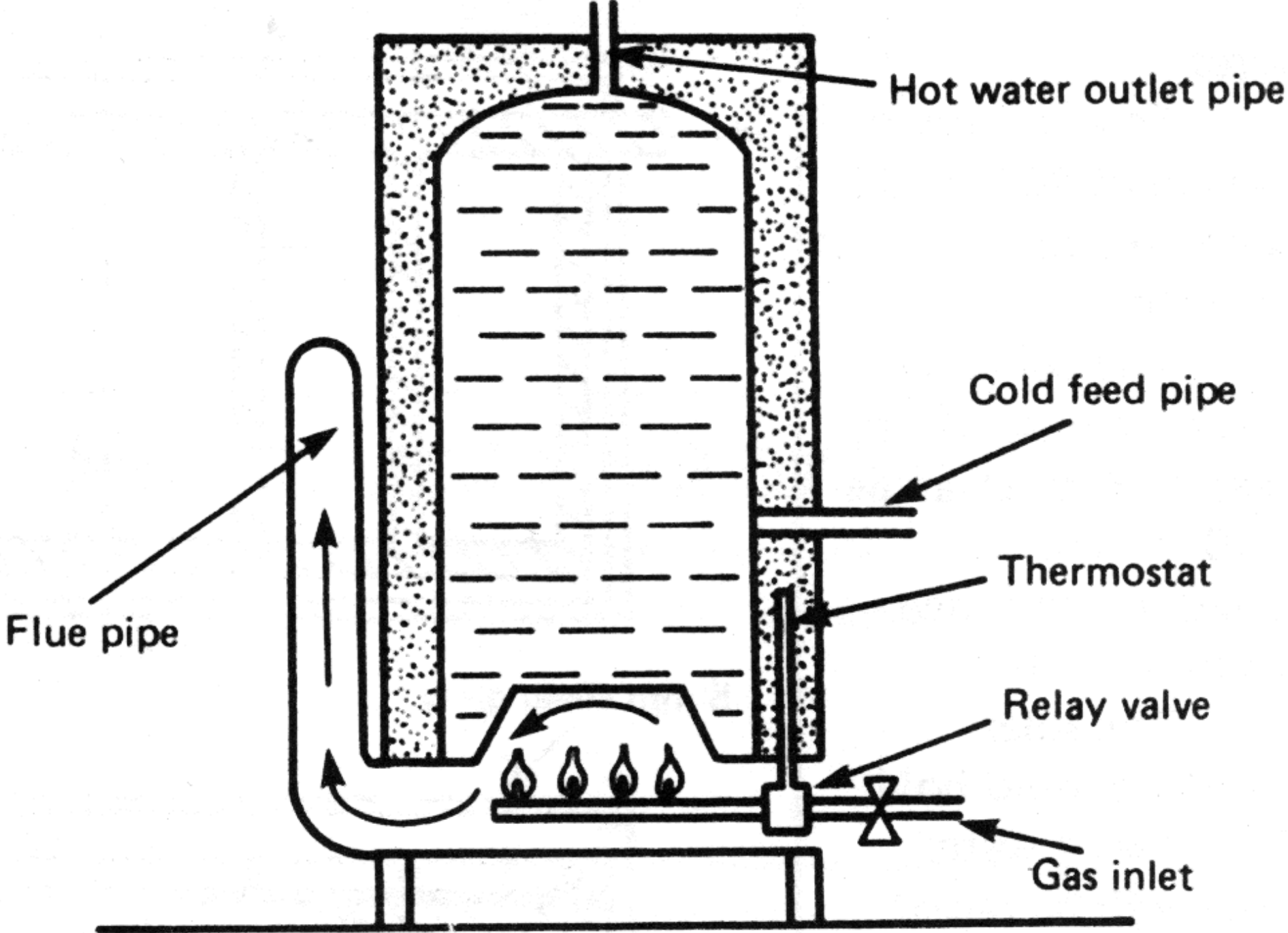

(Source: Hall, F. and Greeno, R., 2008. *Building Services Handbook*)

# Gas & electric water heaters



- Electric water heaters

- Common types:
  - Instantaneous
  - Cistern type (with storage)
- Usually power consumptions of up to 6 kW
- May be fitted above basins, baths or sinks
- Hot water pipes must be as short as possible
- Immersion heater must be electrically earthed
- Cable of appropriate size (may need 3 phase electrical supply)



# Instantaneous electric water heater (non-pressure type)

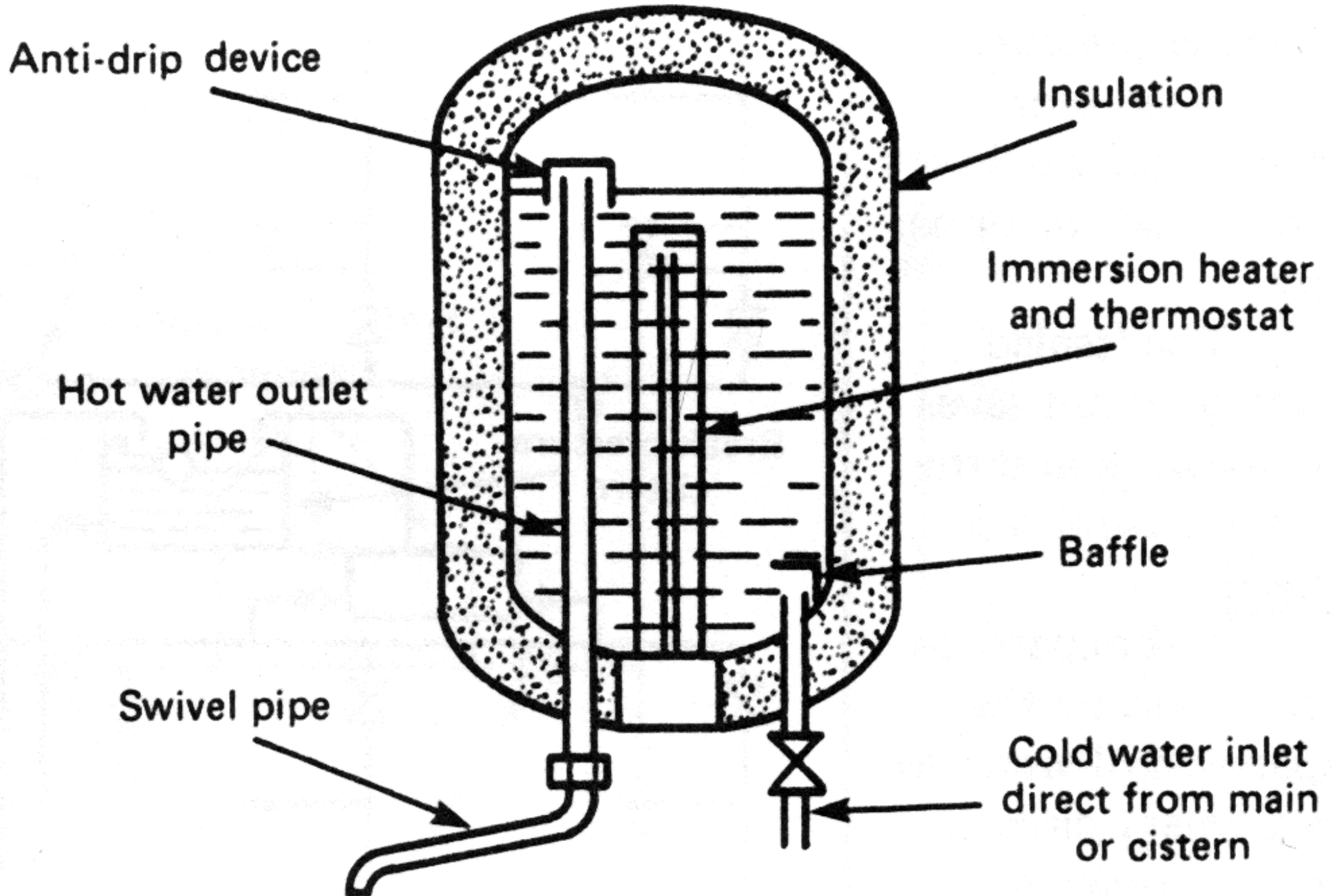

# Typical uses for instantaneous electric water heaters

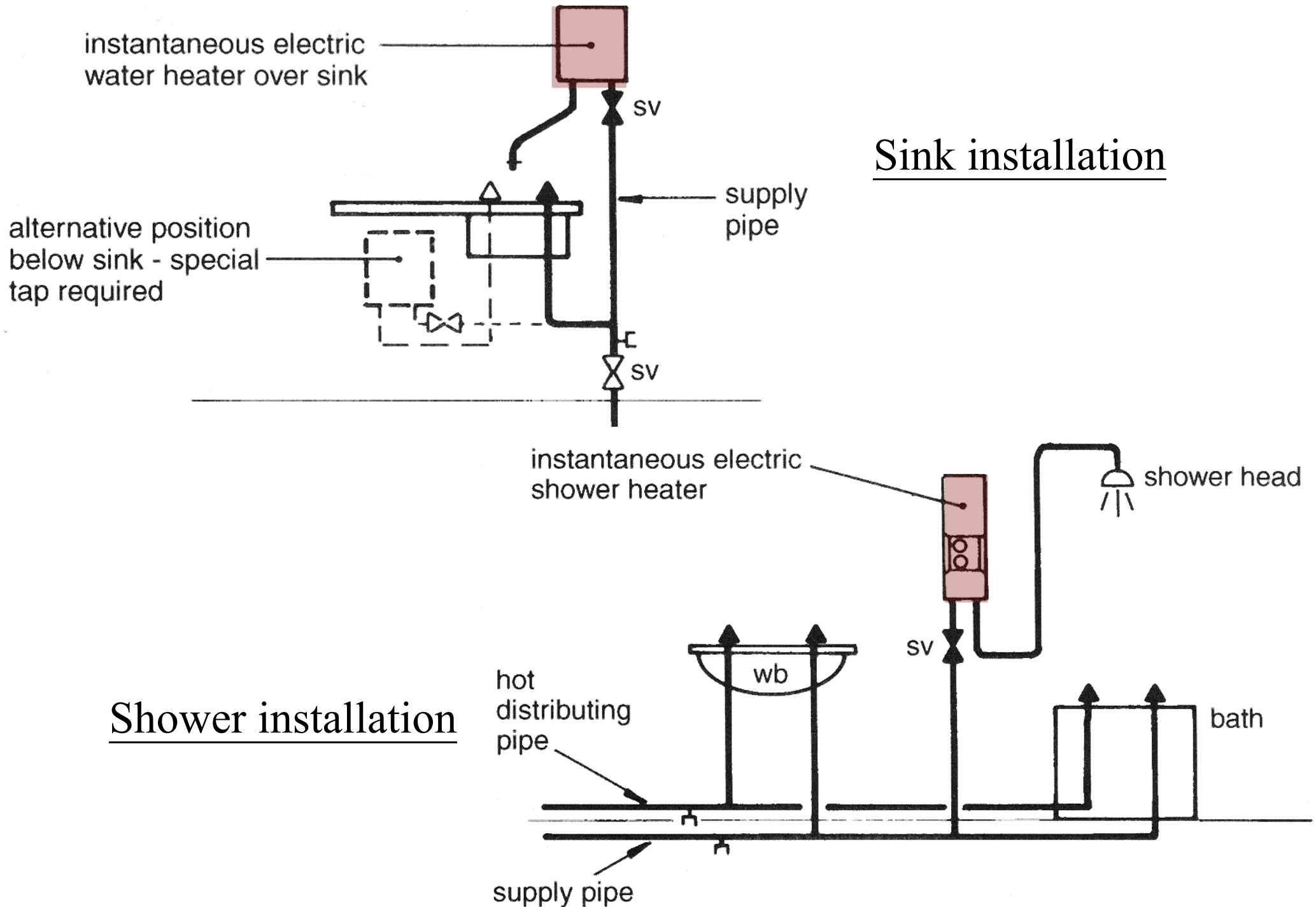

# Cistern type water heater

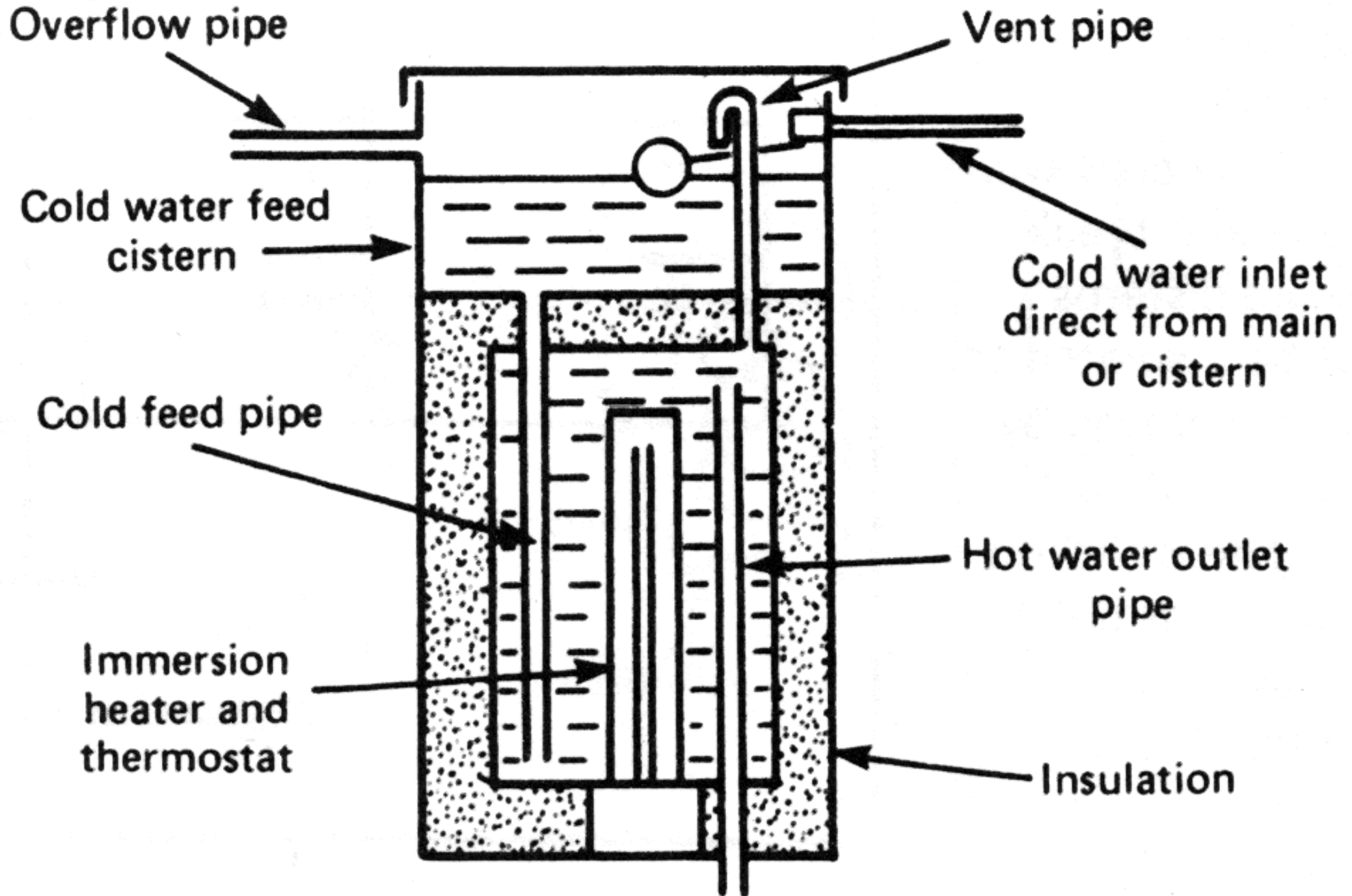

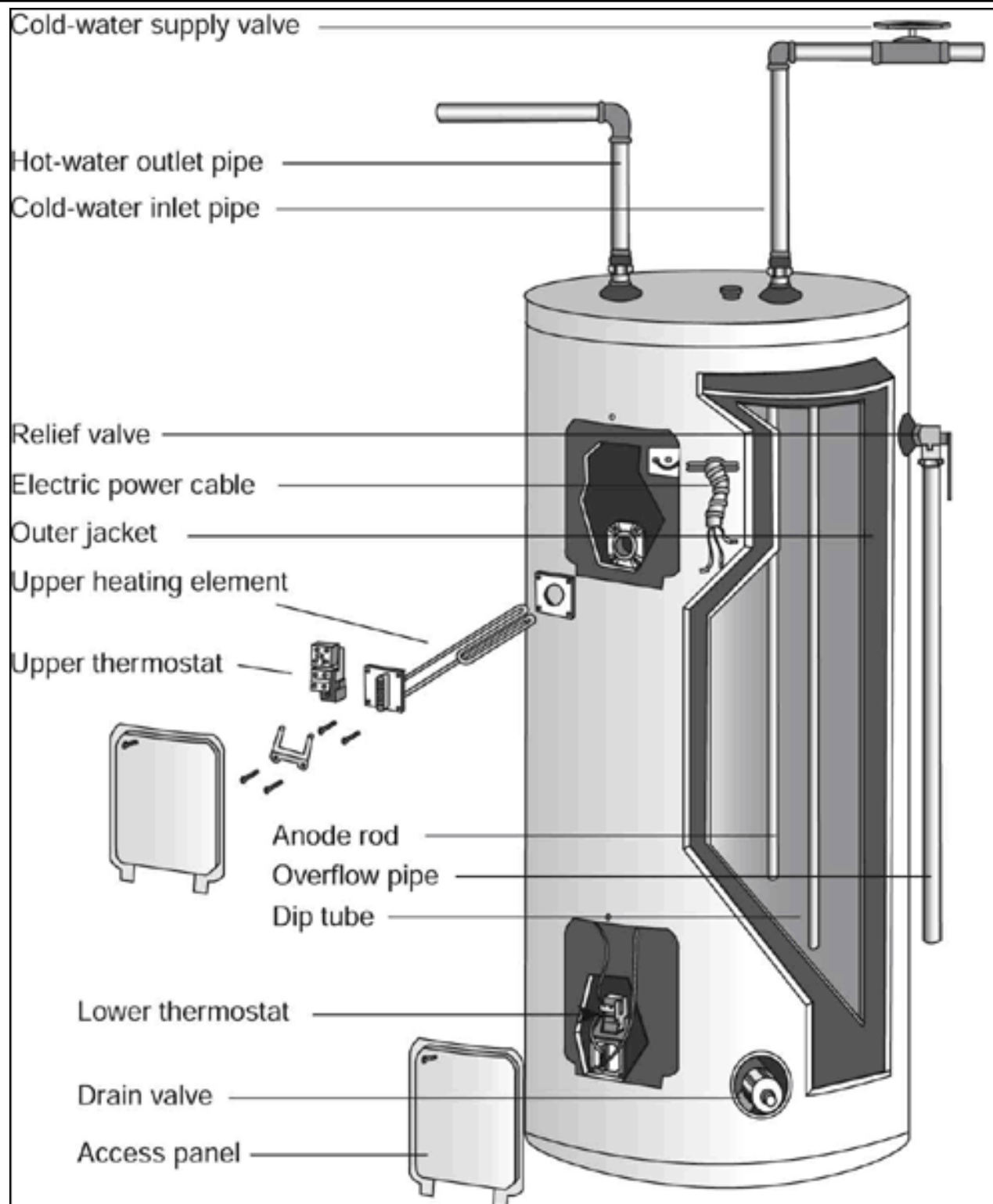

Components  
of a large  
electric water  
heater



# Gas & electric water heaters



- Water-jacketed tube heaters

- Usually as a form of instantaneous heater
- Heat exchanger in a reservoir of primary hot water
- Cold water feeds may be from the mains or from a water tank
- Primary circuit may be vented or sealed system
- Heat exchanger warms secondary supply water

# Water-jacketed tube heater

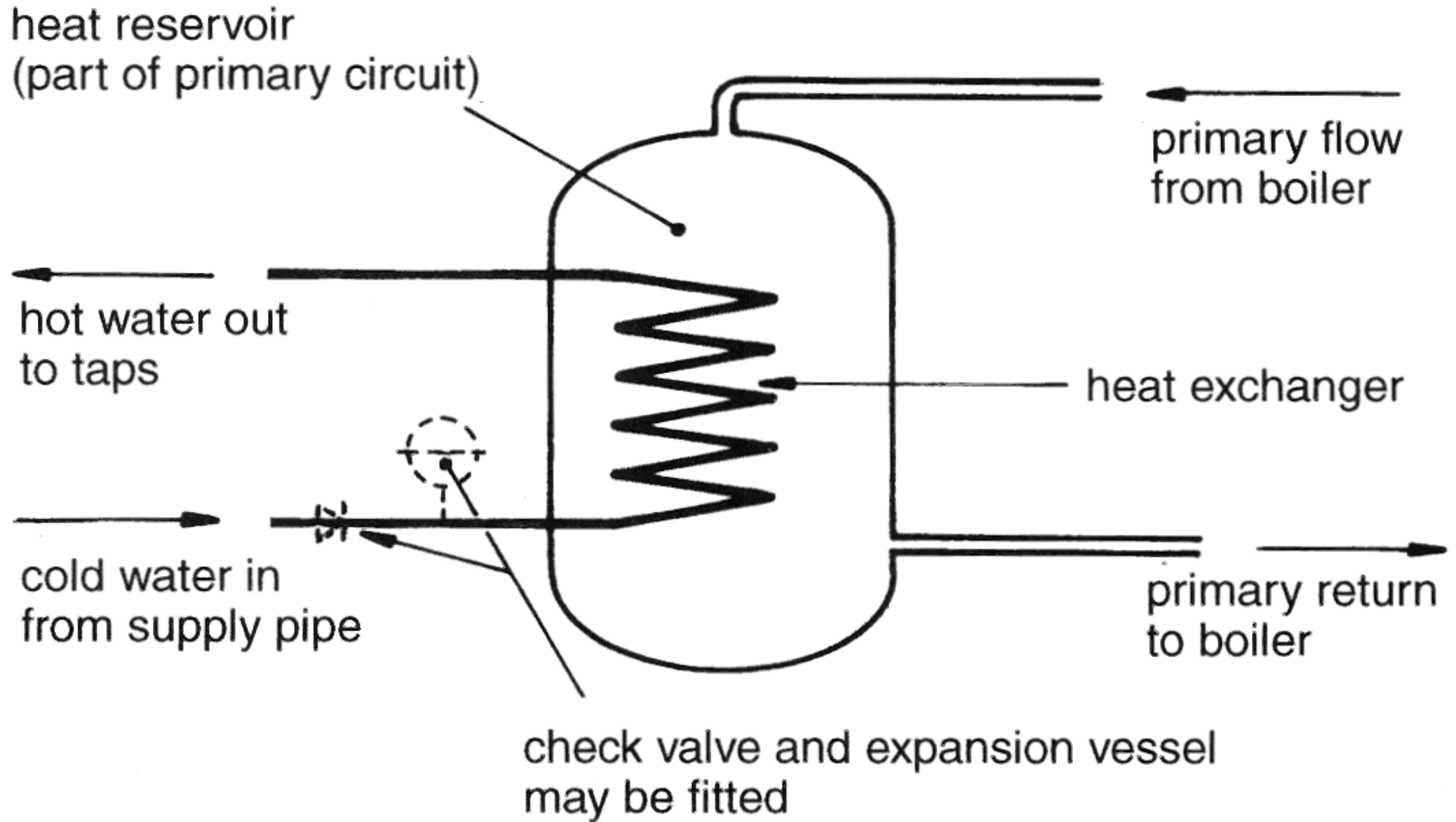

# Sizing hot water systems for households

## Electric storage hot water services

Off-peak electricity rate (storage type heater)*		Peak electricity rate (continuous type heater)**	
Max. no. of persons served	Capacity (litres)	Max. no. of persons served	Capacity (litres)
1 – 3	160	2	40
2 – 4	250	3	63
3 – 6	315	4	80
5 – 8	400	5	125

\* Water is heated overnight to provide adequate hot water for daily usage.

\*\* Can be very expensive to run so should only be used when other options are not possible. For example, where space is limited.

# Sizing hot water systems for households (cont'd)

## Gas water heaters

Storage		Instantaneous (continuous flow)	
Max. no. of persons served	Capacity (litres)	Max. no. of outlets served at one time	Flow rate (litres per minute)
1 – 3	90	1	16
2 – 4	130	2	20
3 – 5	170	3+	24
4 – 6	200		
5 – 9	260		

# Sizing hot water systems for households (cont'd)

## Solar hot water

No. of persons served	Capacity (litres)	Collector (m <sup>2</sup> )
1 – 2	160 – 200	2
3 – 4	300 – 370	4
5 – 6	440	6

# Solar hot water & heat pumps



- Solar water heating

- ‘Renewable’ or green energy
- Simple system (e.g. domestic):
  - Solar collector + direct feed gravity

- Types of solar collectors:

- Formed plastic
- Flat plate
- Evacuated tube (heat pipe)

- Supplemented by gas/electric heating

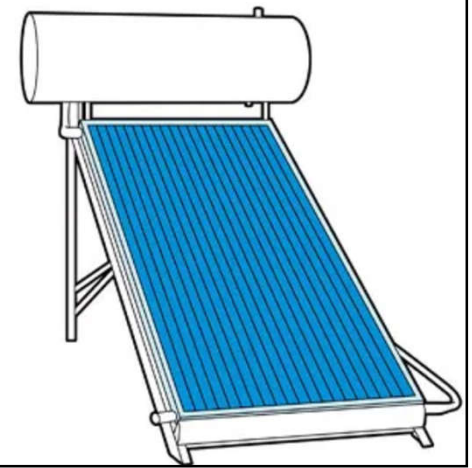
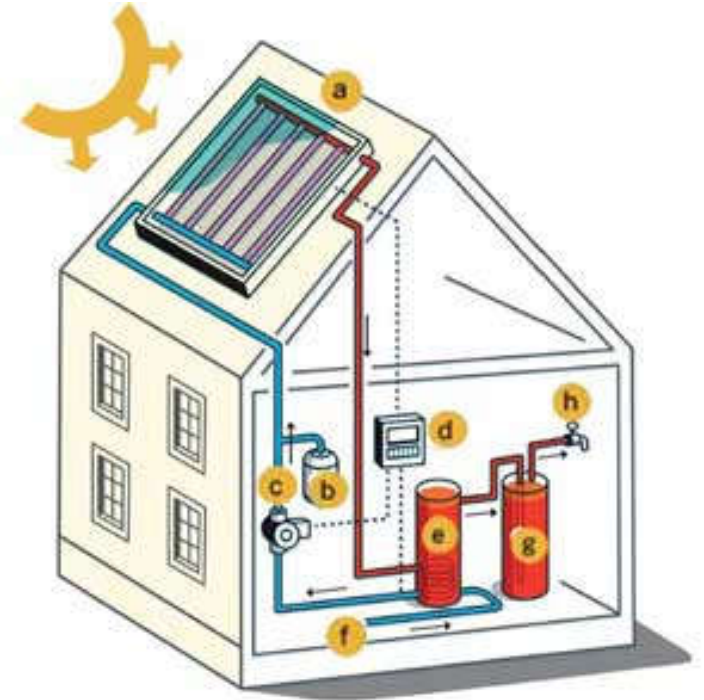

# Heat transfer processes at a flat-plate solar collector

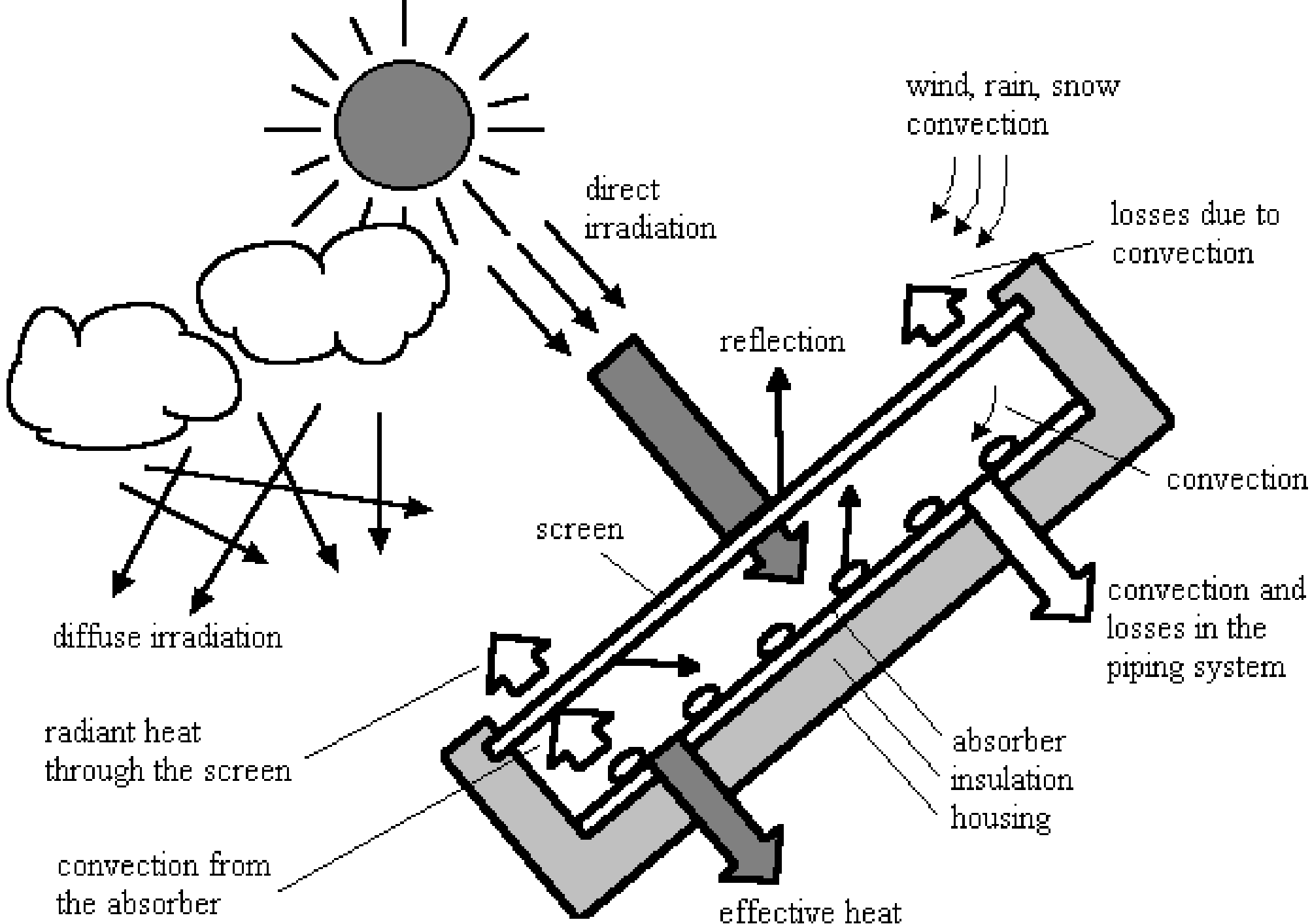

# Solar hot water system

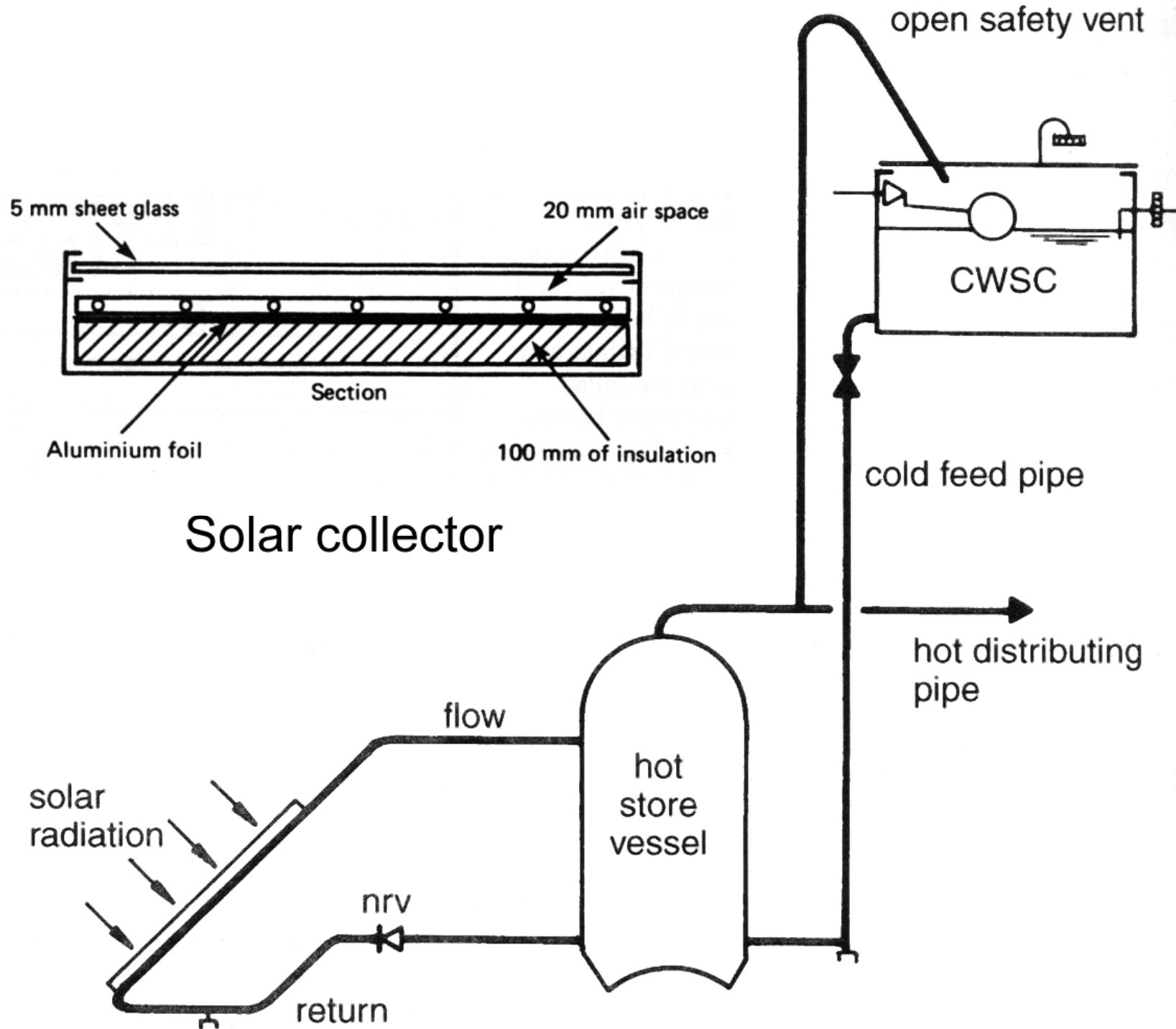



# Solar hot water for a school in Guangzhou



Inclined angle?

# Solar hot water systems

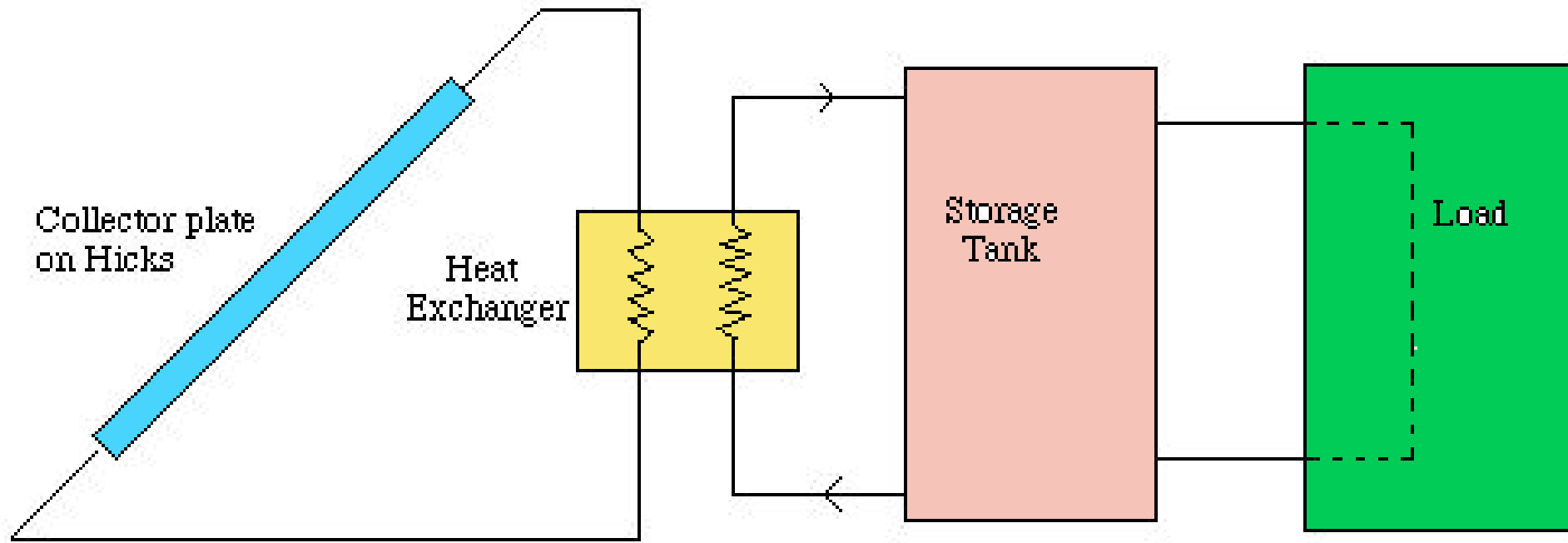

**Flat board type**



**Vacuum glass pipe type**

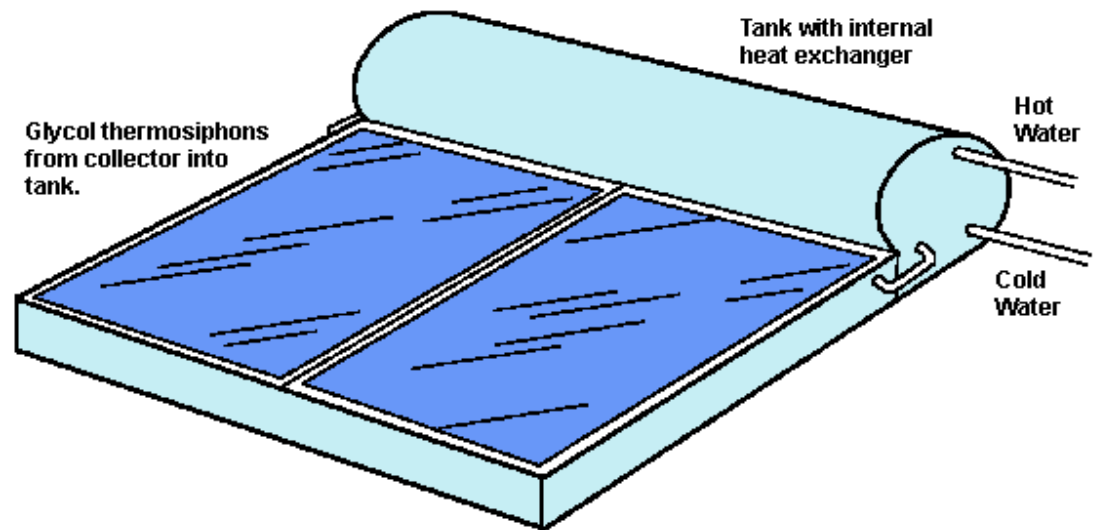

**Simple domestic system  
(with integral storage tank)**

# Active (or pumped) solar hot water system

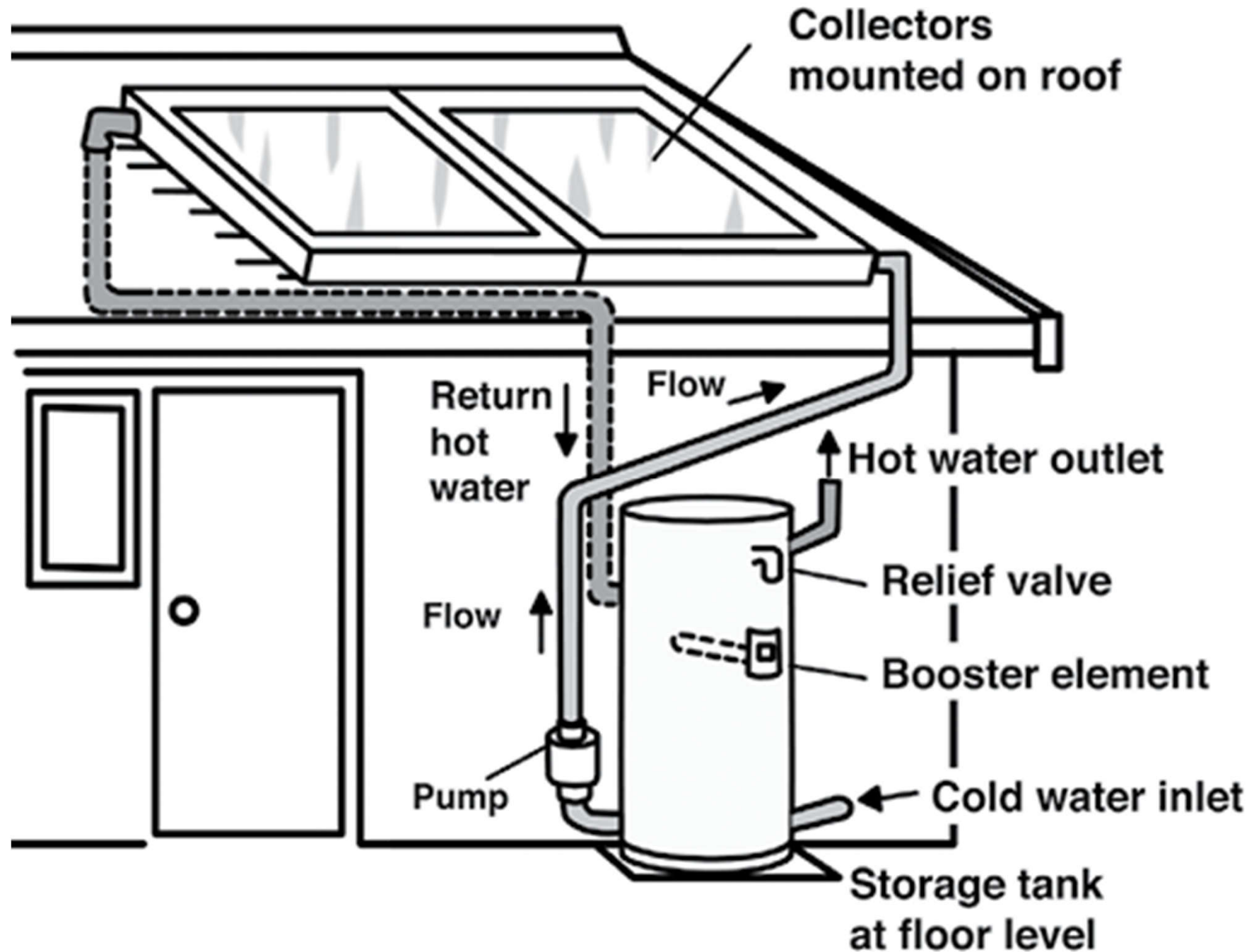

# Solar collector with thermosyphon flow

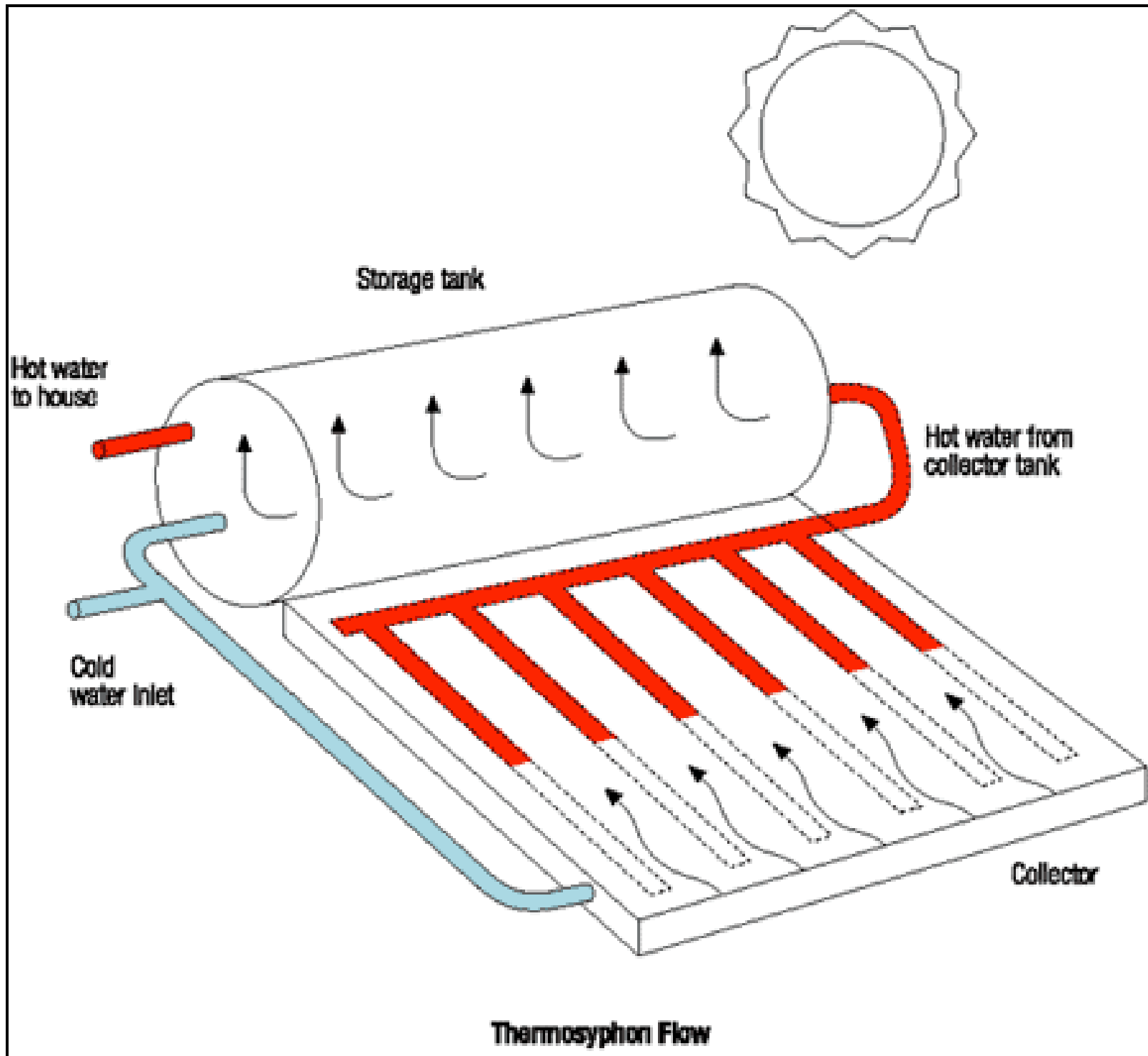

# Heat pipe evacuated-tube solar collector

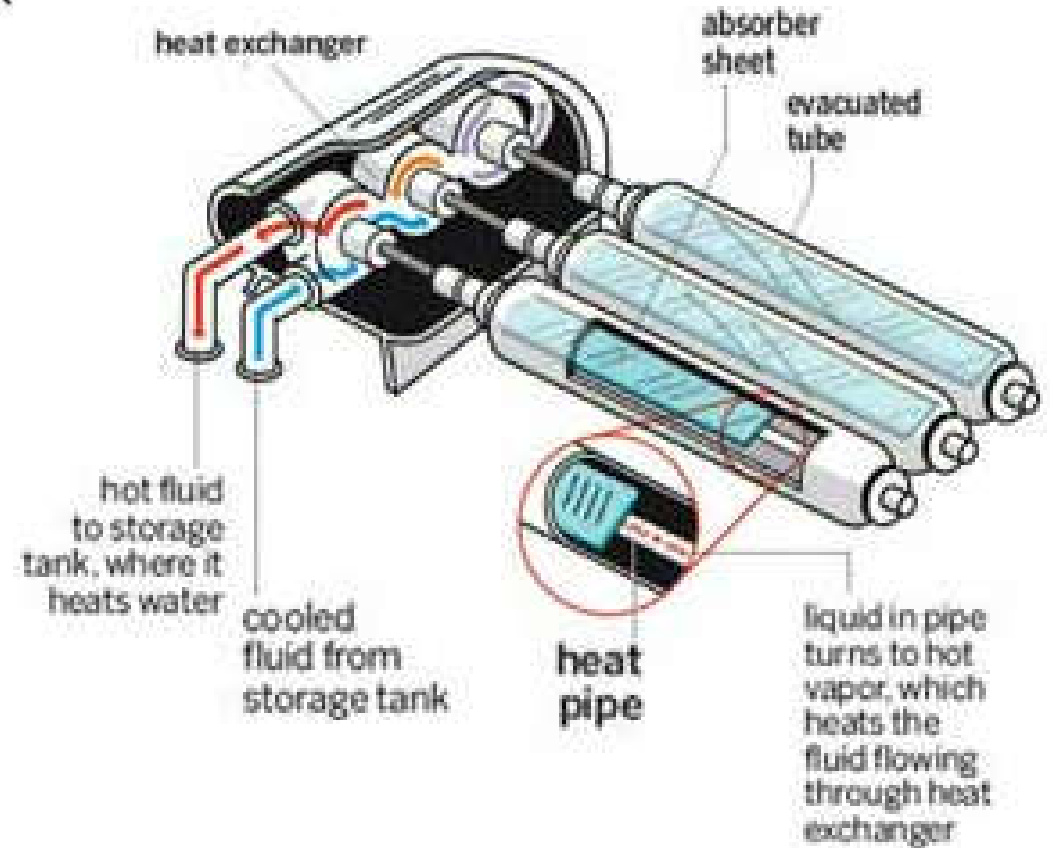
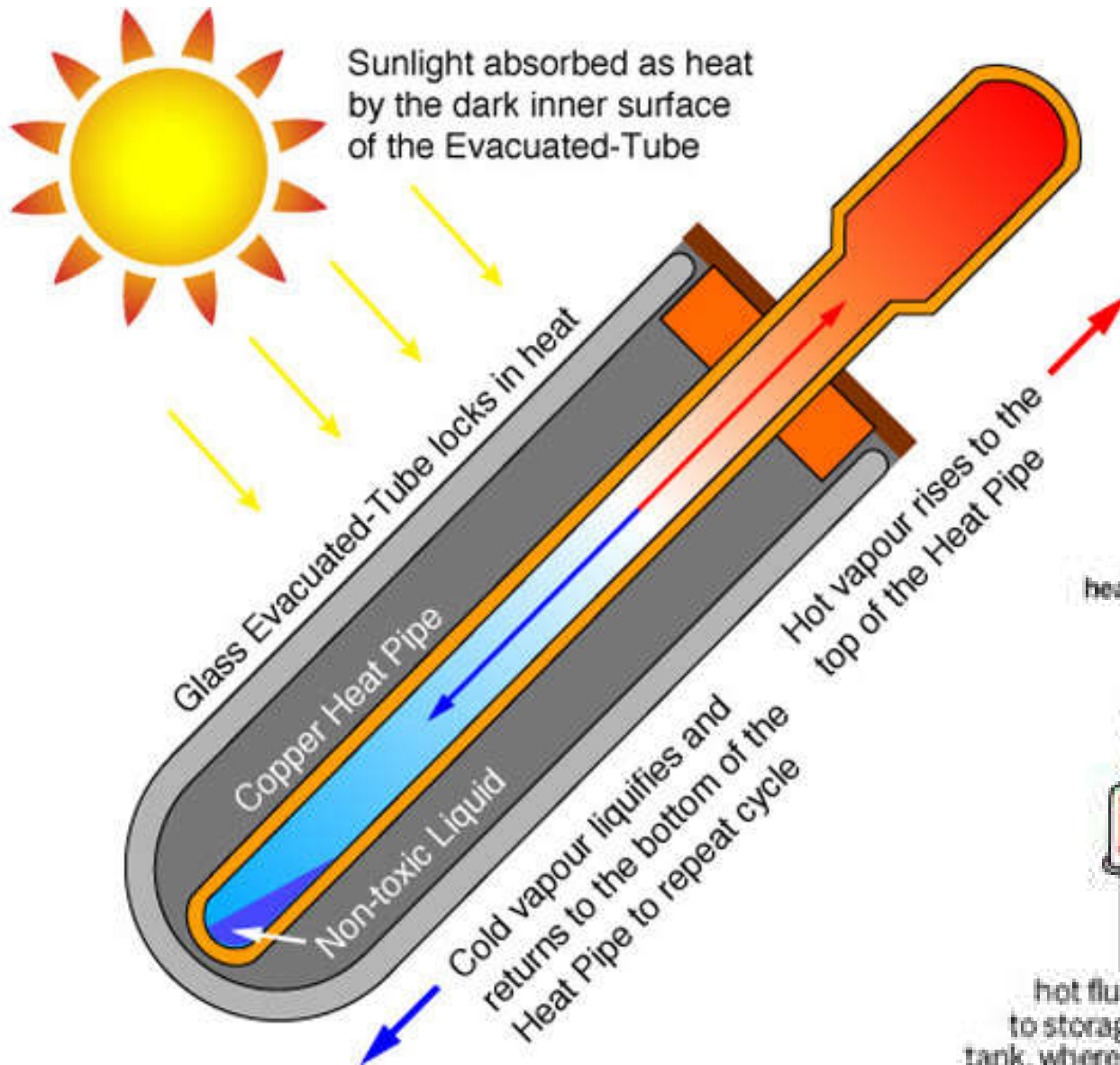

# Evacuated-tube solar hot water system



## Comparison of flate-plate and evacuated-type collectors

	<b>Pros</b>	<b>Cons</b>
Flate-plate collectors 平板式太陽能集熱器	<ul style="list-style-type: none"><li>• capable to deliver moderate temperature hot water</li><li>• lower cost compared with evacuated tube</li></ul>	<ul style="list-style-type: none"><li>• heavier weight</li><li>• larger wind load</li><li>• more susceptible to pipe blockage &amp; leakage</li><li>• more complications in maintenance</li></ul>
Evacuated-type collectors 真空管太陽能集熱器	<ul style="list-style-type: none"><li>• lower heat loss to surrounding</li><li>• capable to deliver moderate to high temperature water (60-80 °C)</li><li>• lighter support structure</li><li>• simplicity in maintenance</li></ul>	<ul style="list-style-type: none"><li>• higher capital cost compared with flat plate</li></ul>

# Solar collector performance

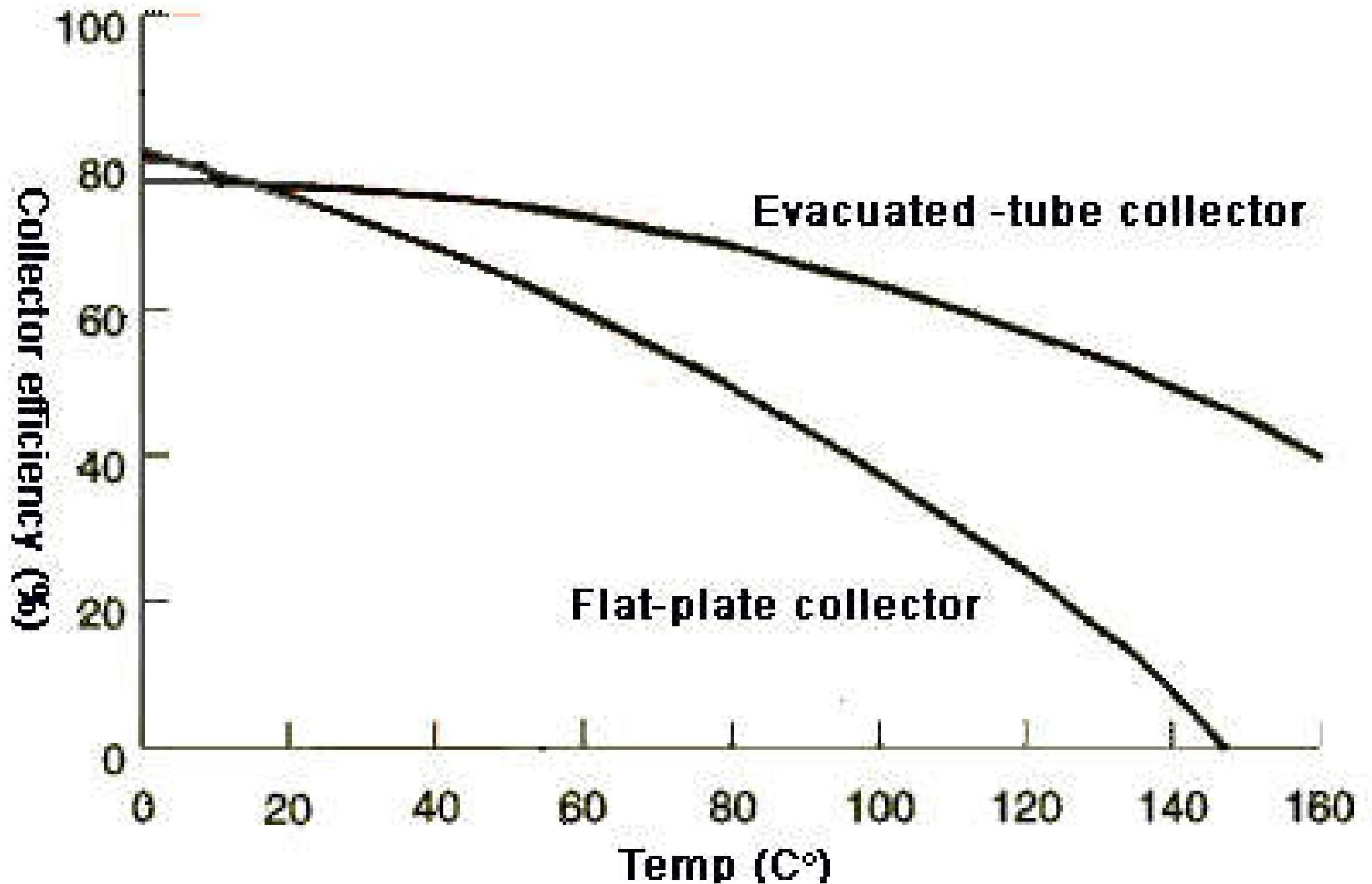



# Direct type (open-loop) solar hot water heating system

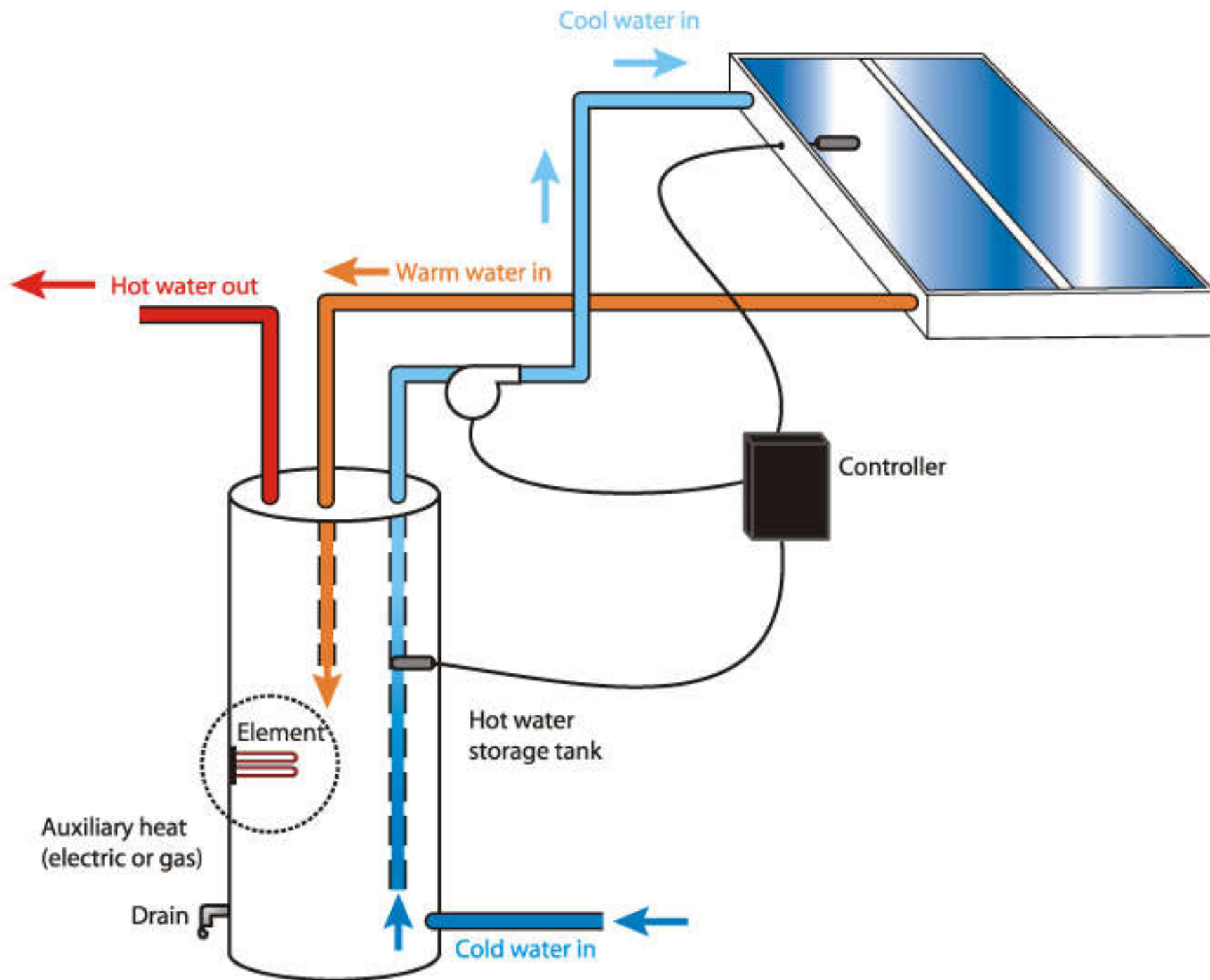

# Indirect type (closed-loop) solar hot water heating system (freeze protection)

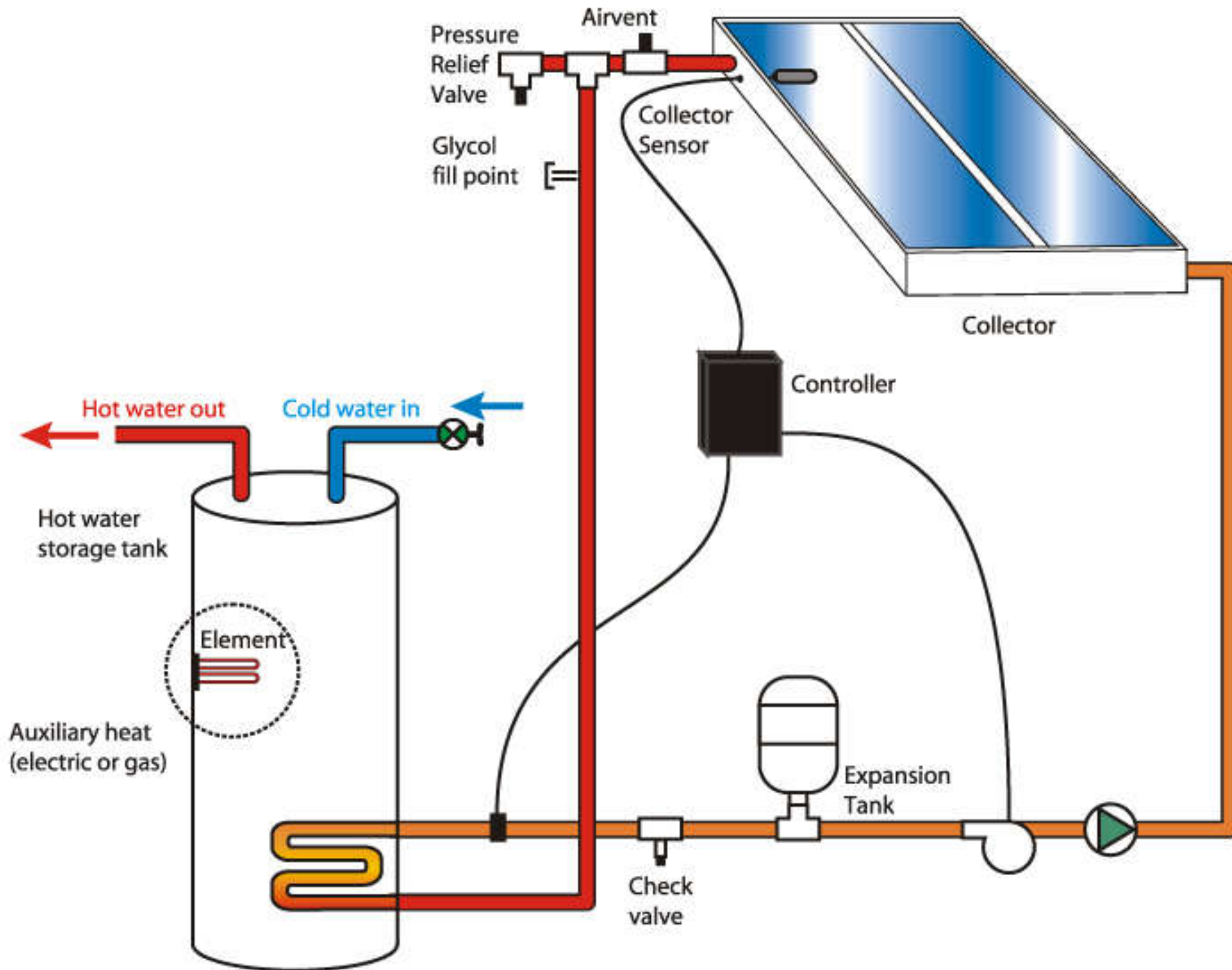

# Household-scale solar water heating system at village houses

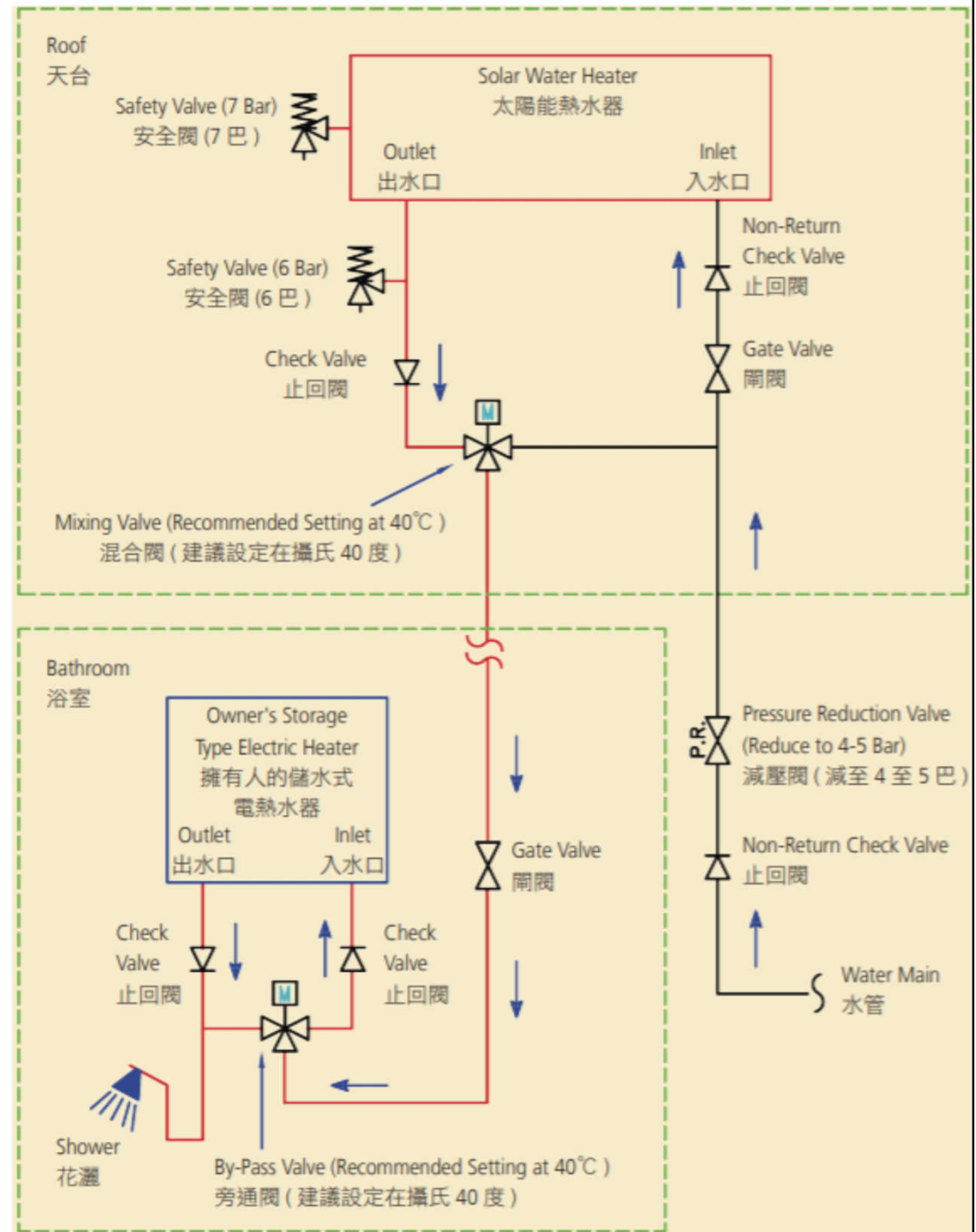
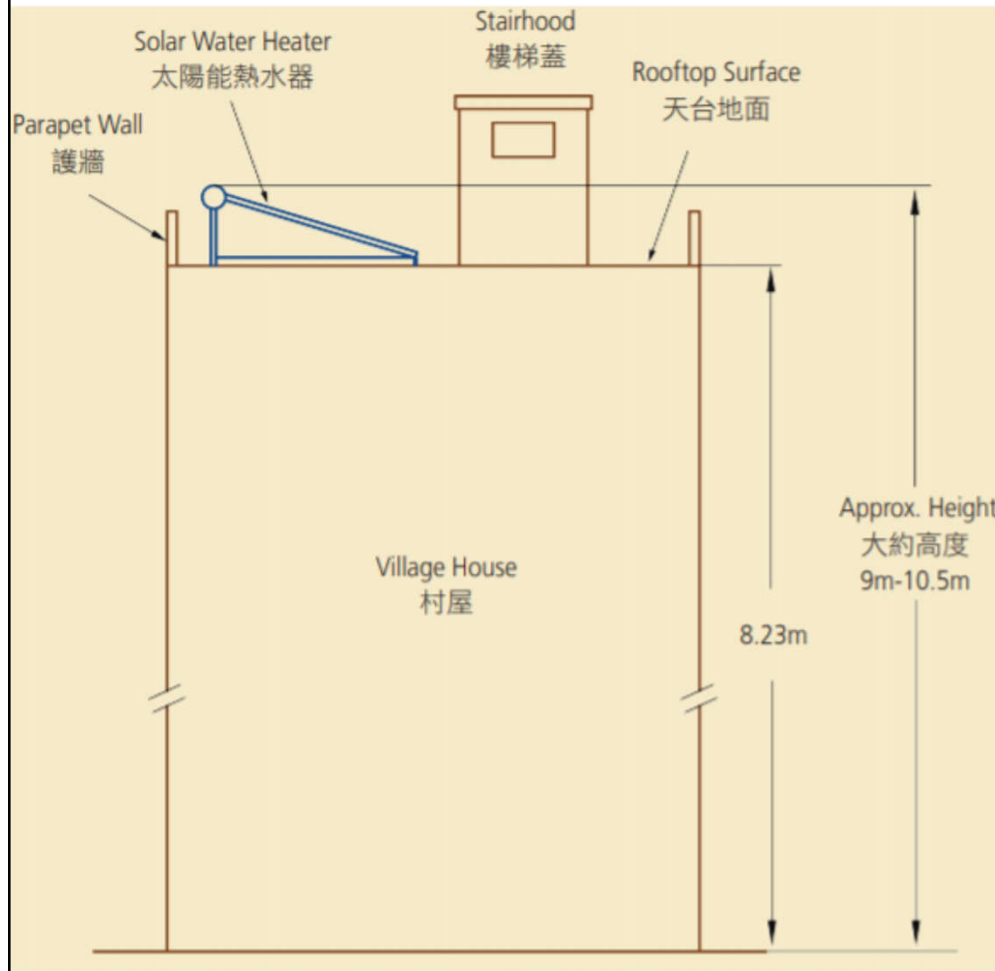

# Solar hot water & heat pumps



- Heat pump water heaters (HPWH)

- An effective tool to produce hot water
- Extract energy from ground, water, or ambient air
- Typical applications:
  - To preheat conventional hot water systems
  - To augment existing systems
  - To supply full hot water
- Reverse of the normal refrigeration cycle

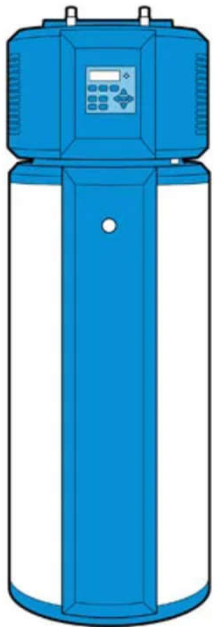

# Basic principles of heat pump

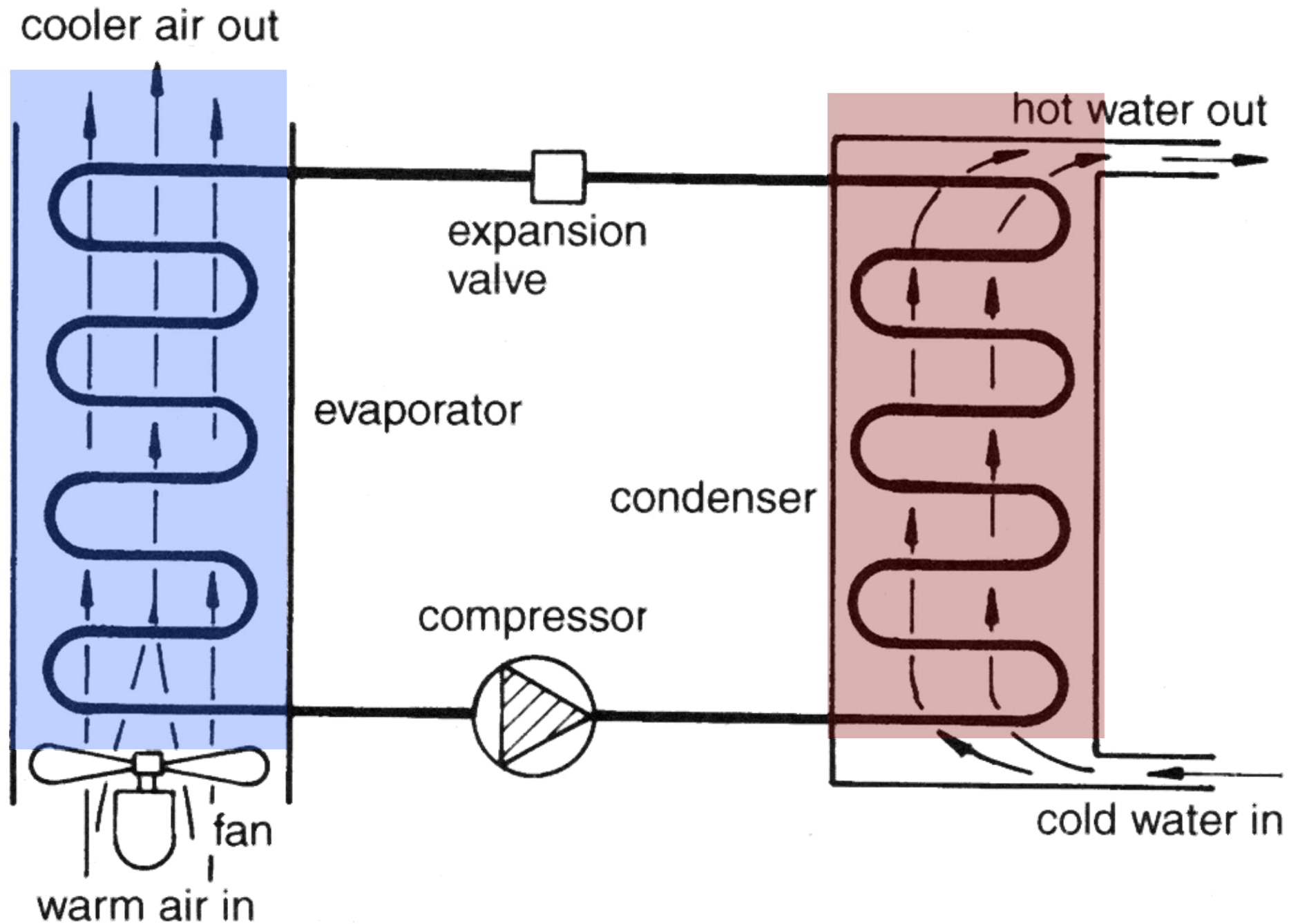

# Working principle of heat pump water heater

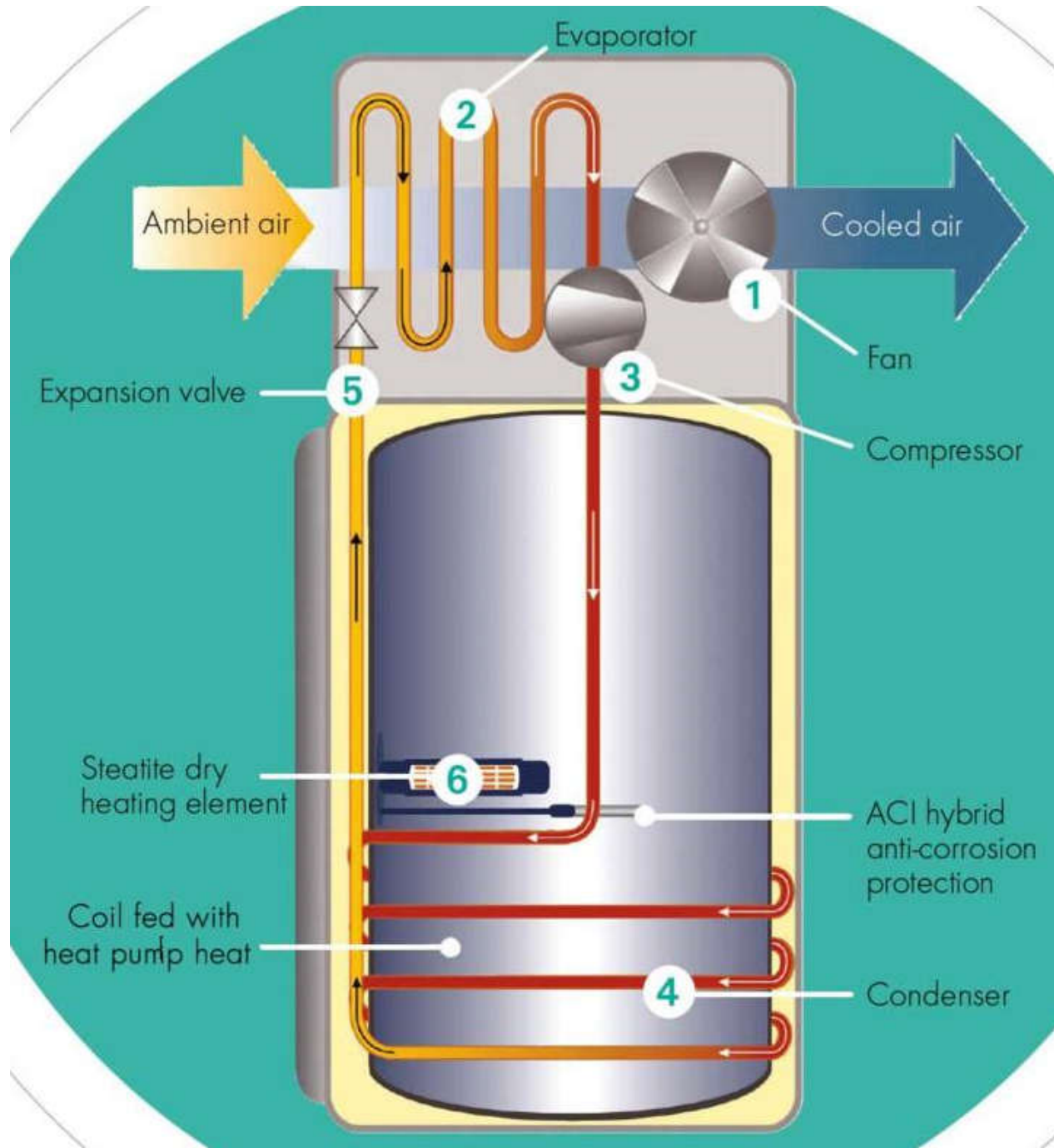

# Heat pump water heaters

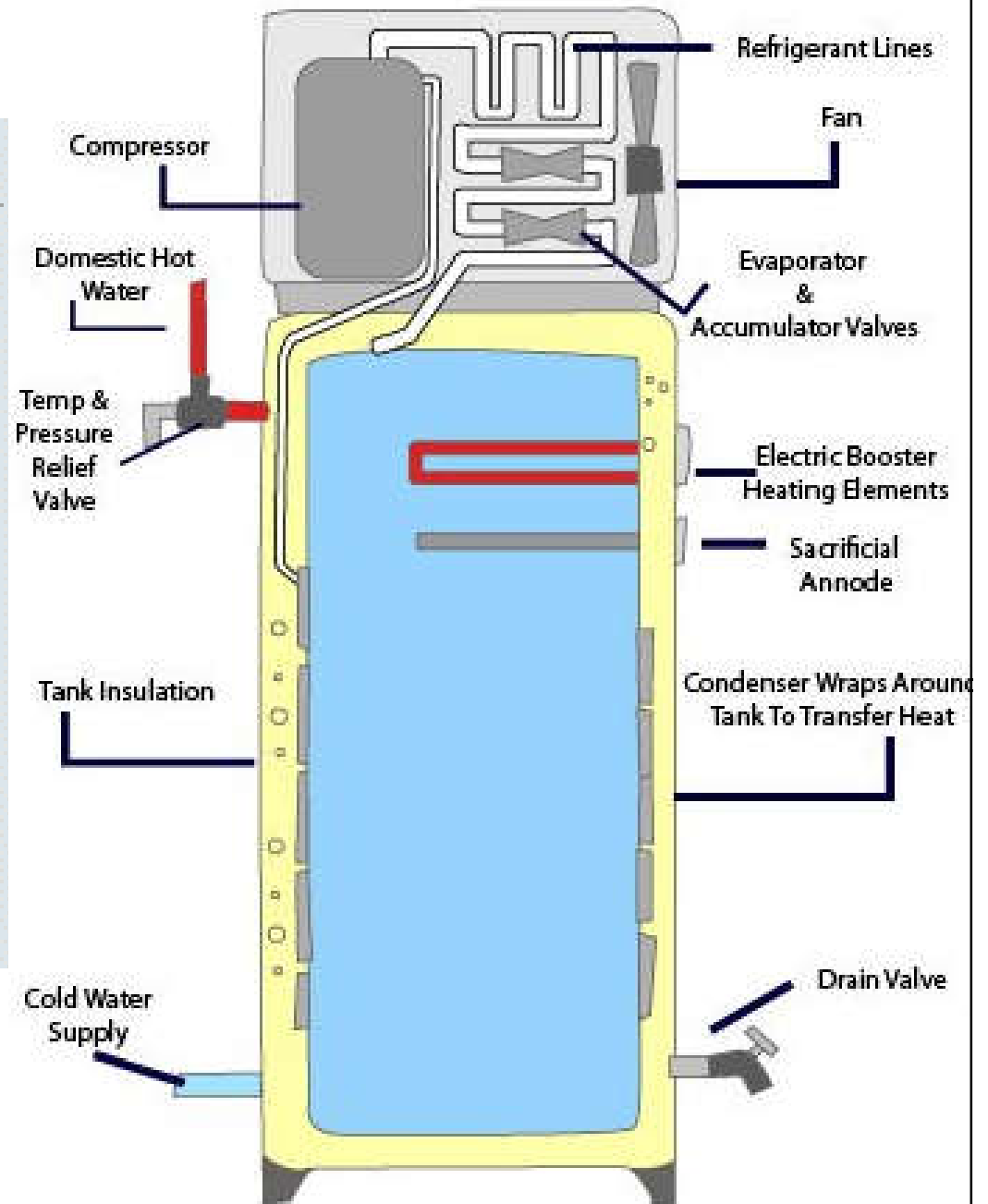
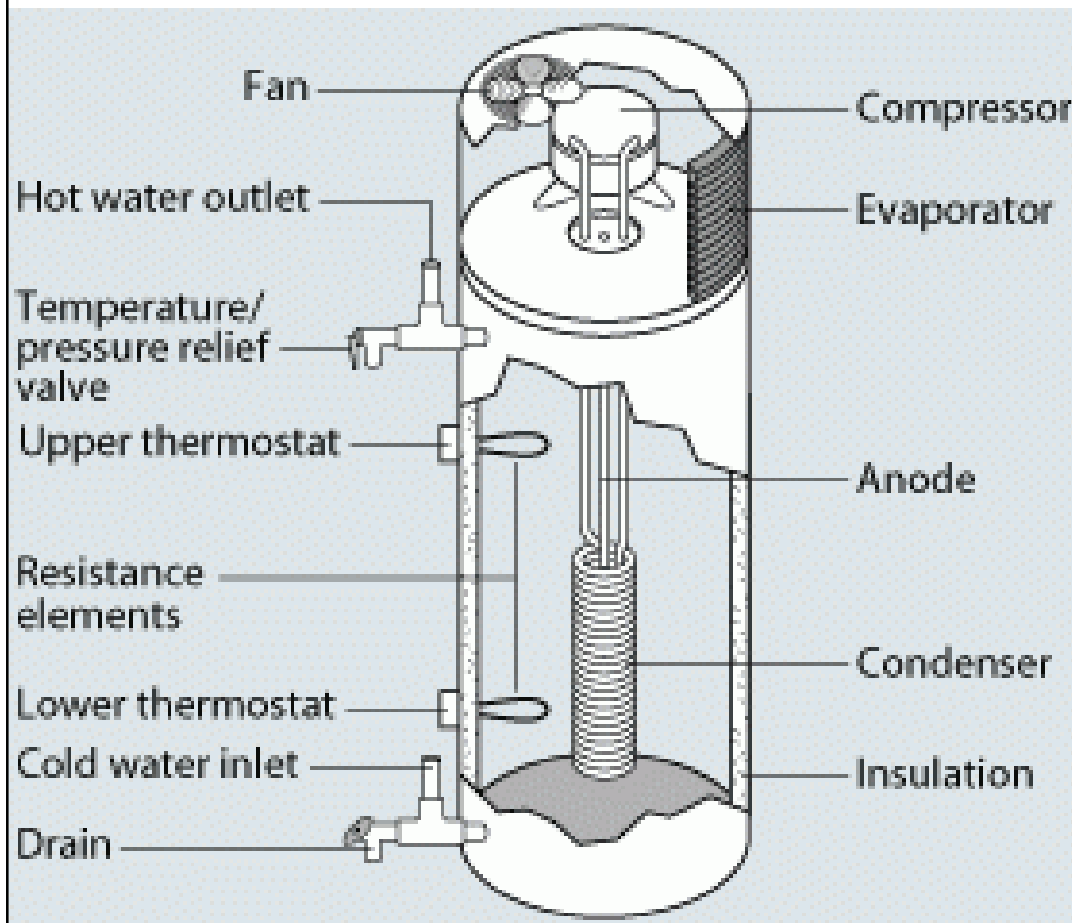

Video: How a Heat Pump Water Heater Works (2:01)

<https://youtu.be/EMdZr-TAga0>

(Image sources: <https://www.energy.gov/energysaver/water-heating/heat-pump-water-heaters>;  
<https://cdn2.hubspot.net/hubfs/91341/waterHeaterModals/waterHeater002a.html>)

# Centralised hot water systems



- Major components:
  - A boiler
  - A hot water storage cylinder or calorifier
  - Cold water storage tank linked by supply and circulatory pipework
- Boiler may be heated by gas, solid fuel or oil
  - Position of the boiler plant
- Pipe insulation is essential (high temperature!)



# Centralised hot water systems



- Direct system

- Water through the boiler can be drawn off from the taps
- Saves the cost of a storage and expansion cistern and associated pipework
- Heated quicker
- Adequate pressure on the main
- Sealed primary circuit can be pumped or can circulate by natural convection

# Direct centralised hot water system

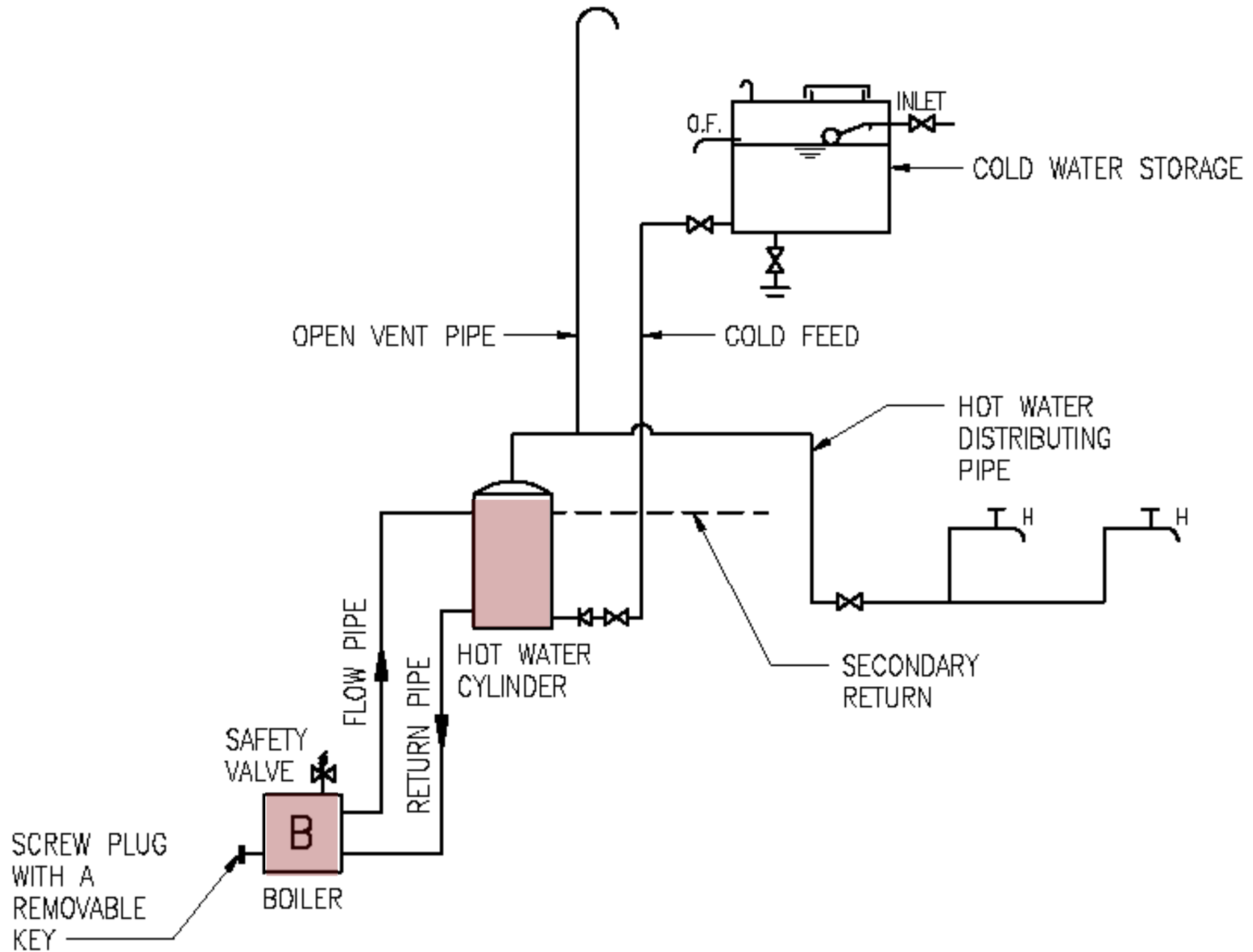

(Source: WSD, 2006. *Handbook on Plumbing Installation for Buildings*)

# Centralised hot water systems



- Indirect system

- Separate circuit for the water drawn off at taps
- Used in hard water areas to prevent scaling of boiler and pipes
- Used when heating is combined with the system
- It costs more than direct system but requires less maintenance
- An expansion vessel in primary pipework to eliminate the need for an expansion cistern, expansion pipe and boiler feeder pipe

# Indirect centralised hot water system

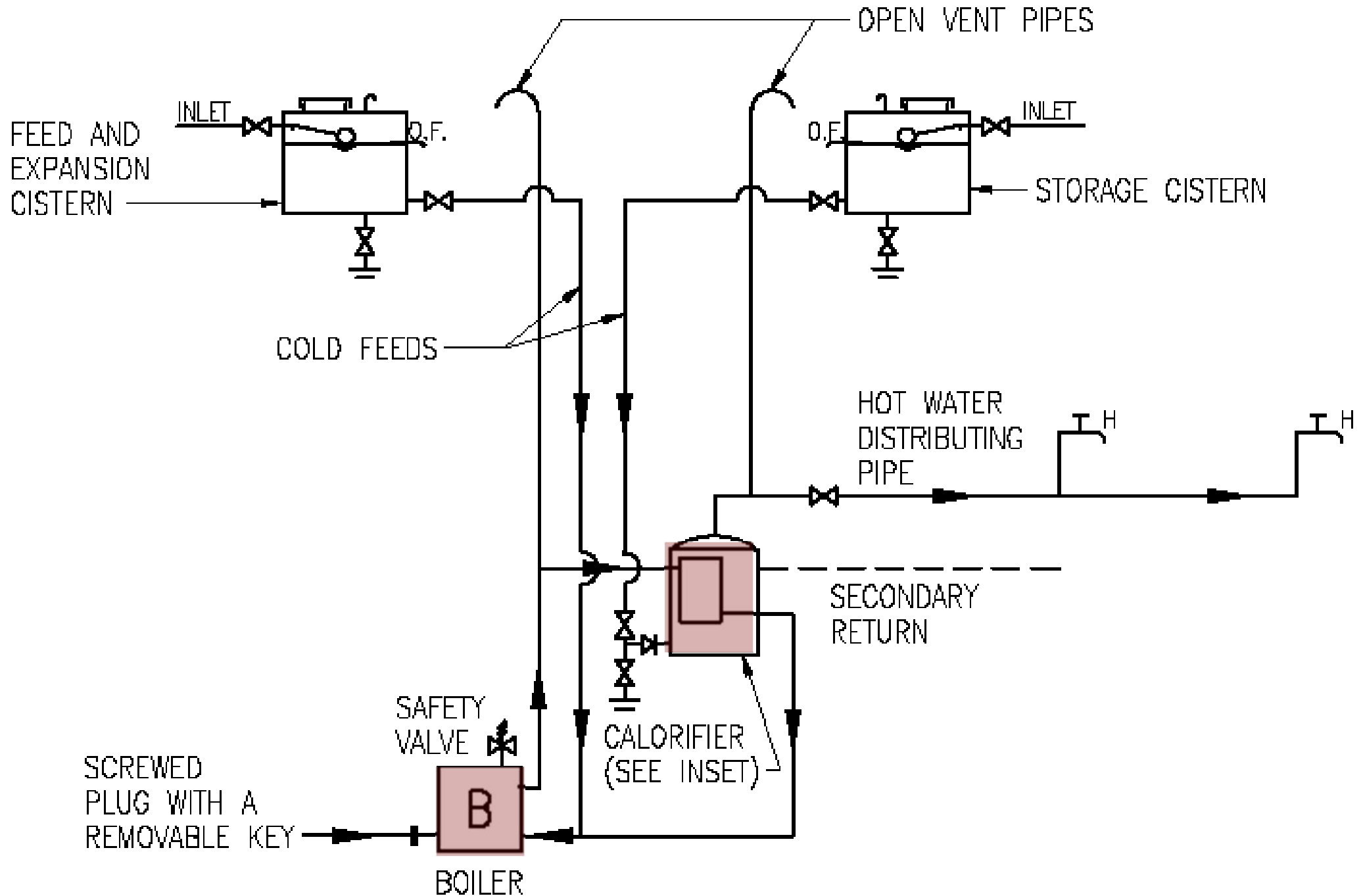

# Essential components of a calorifier

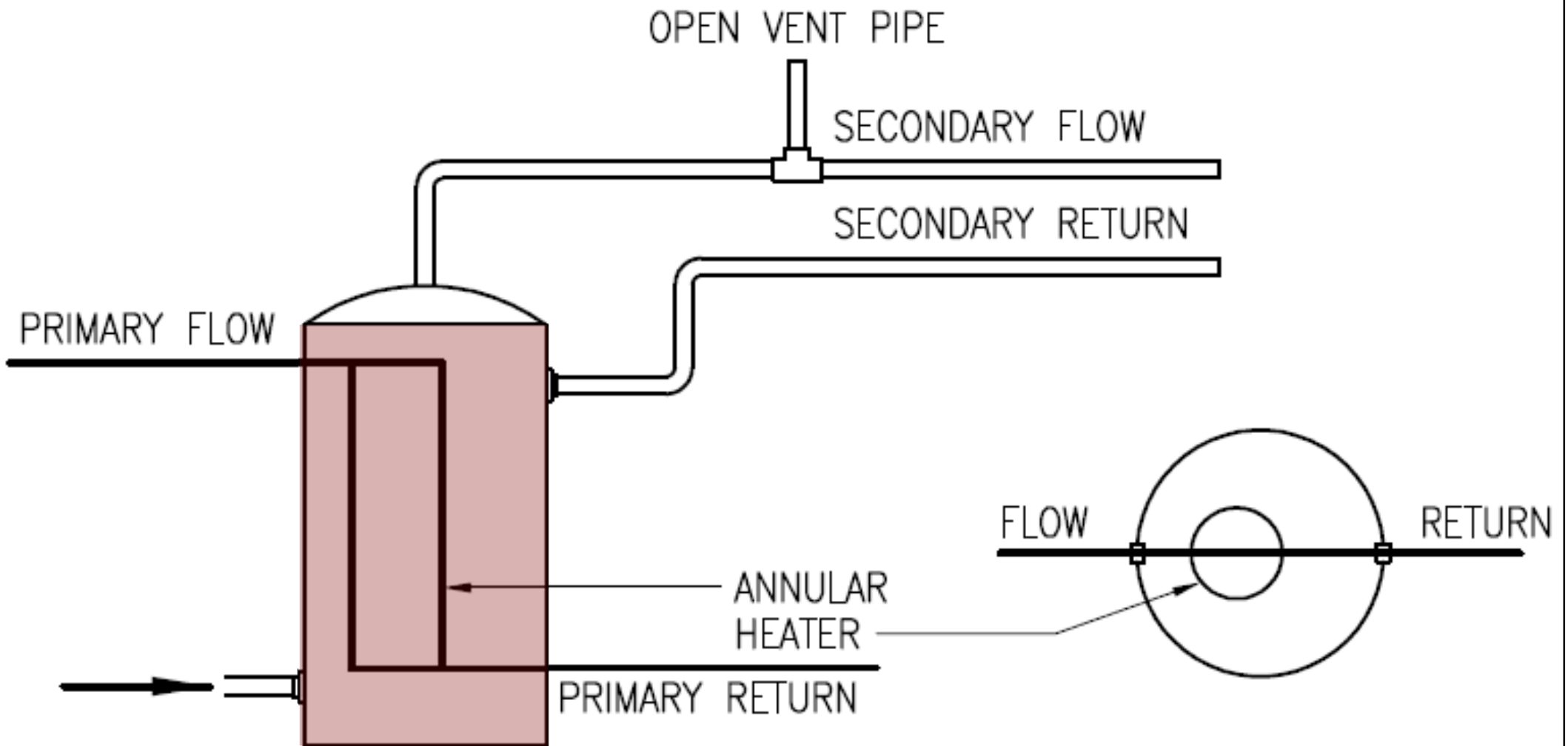

# Centralised hot water systems



- Indirect system with a primatic cylinder
  - Three air locks to prevent mixing of the primary and secondary waters
  - Save cost for expansion and feed tank, primary cold feed and primary vent pipe
  - Limited in use to small installations

# Indirect system with a primatic cylinder

Sf = Secondary flow pipe  
Pf = Primary flow pipe  
Pr = Primary return pipe  
He = Heat exchanger  
Cf = Cold feed pipe

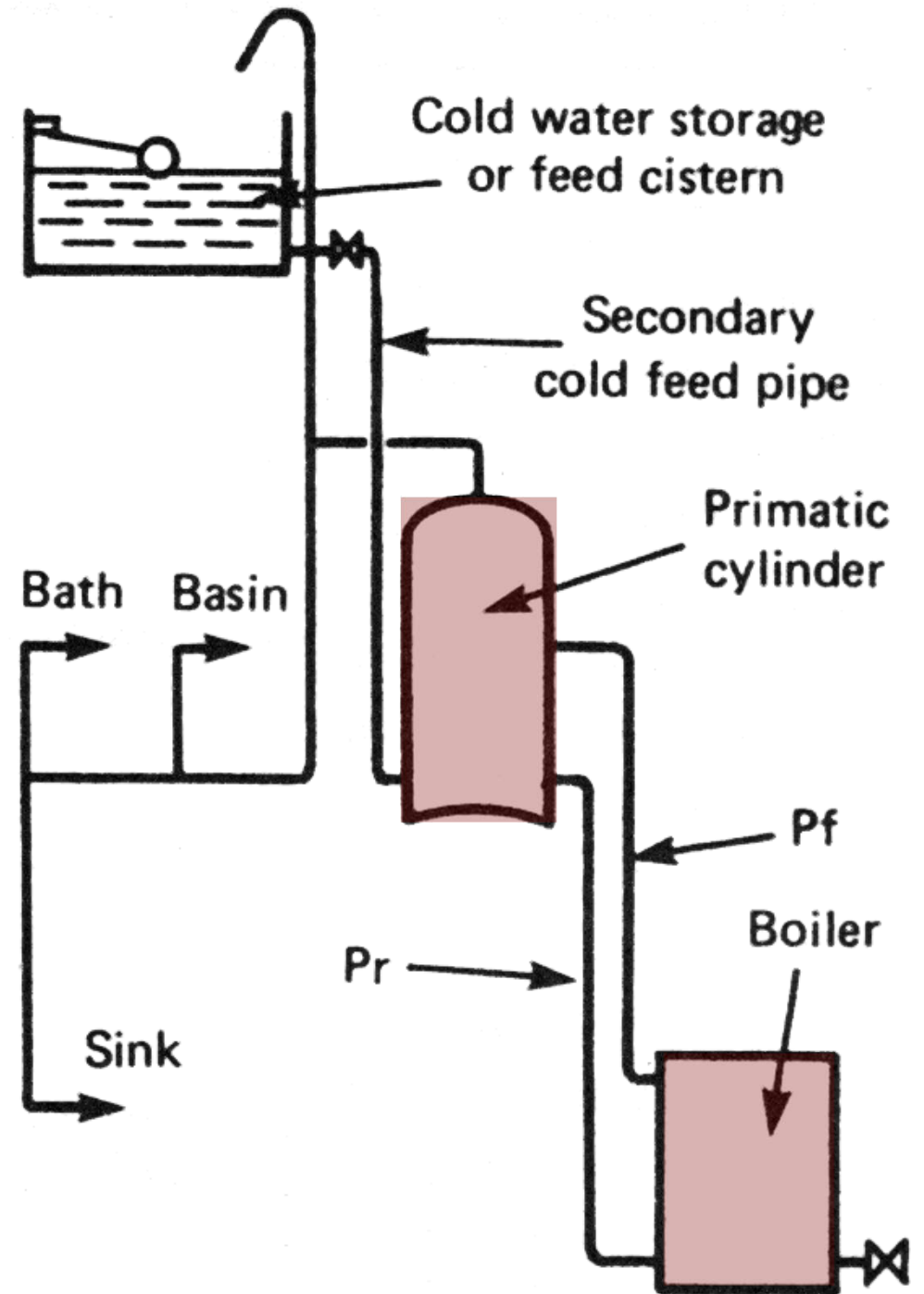
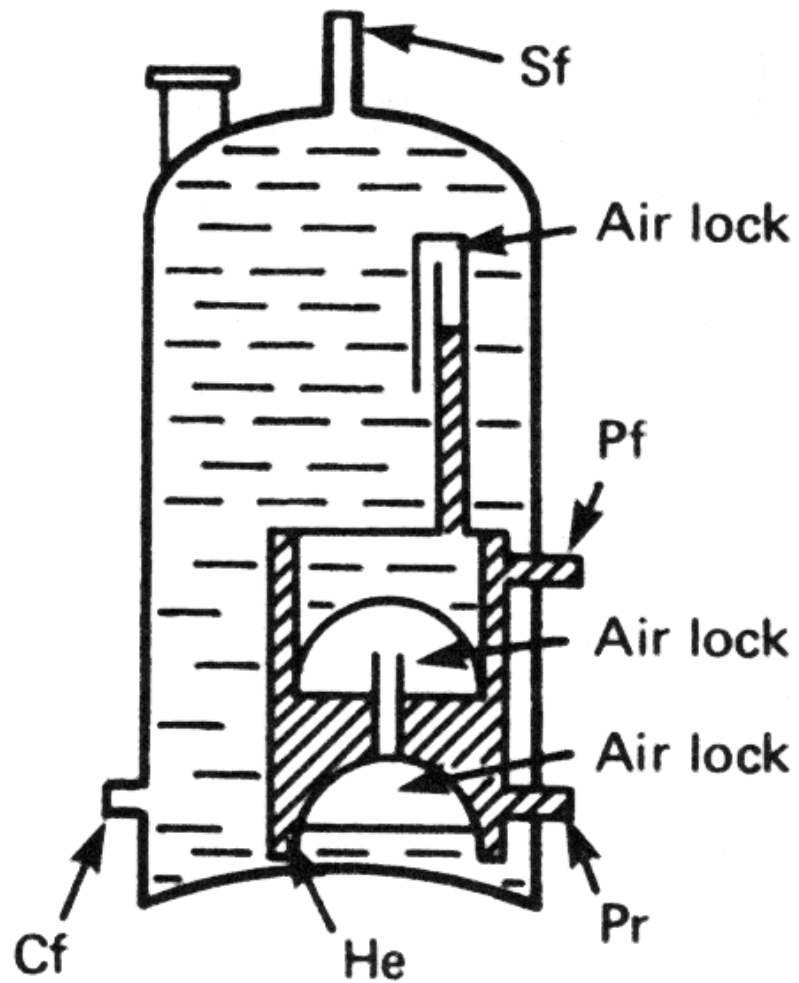

# Centralised hot water systems



- Systems for high-rise buildings
  - More economical to pressurise water in a sealed system
  - Proper zoning is required (e.g. 30 m for each zone)
  - Boiler & calorifiers to withstand water pressure
  - Sealed primary circuit saves on pipework and the expansion and feed tank
  - Expansion vessel takes up the expansion of water in the primary circuit
  - The pipes, calorifiers, head tanks & boiler must be well insulated



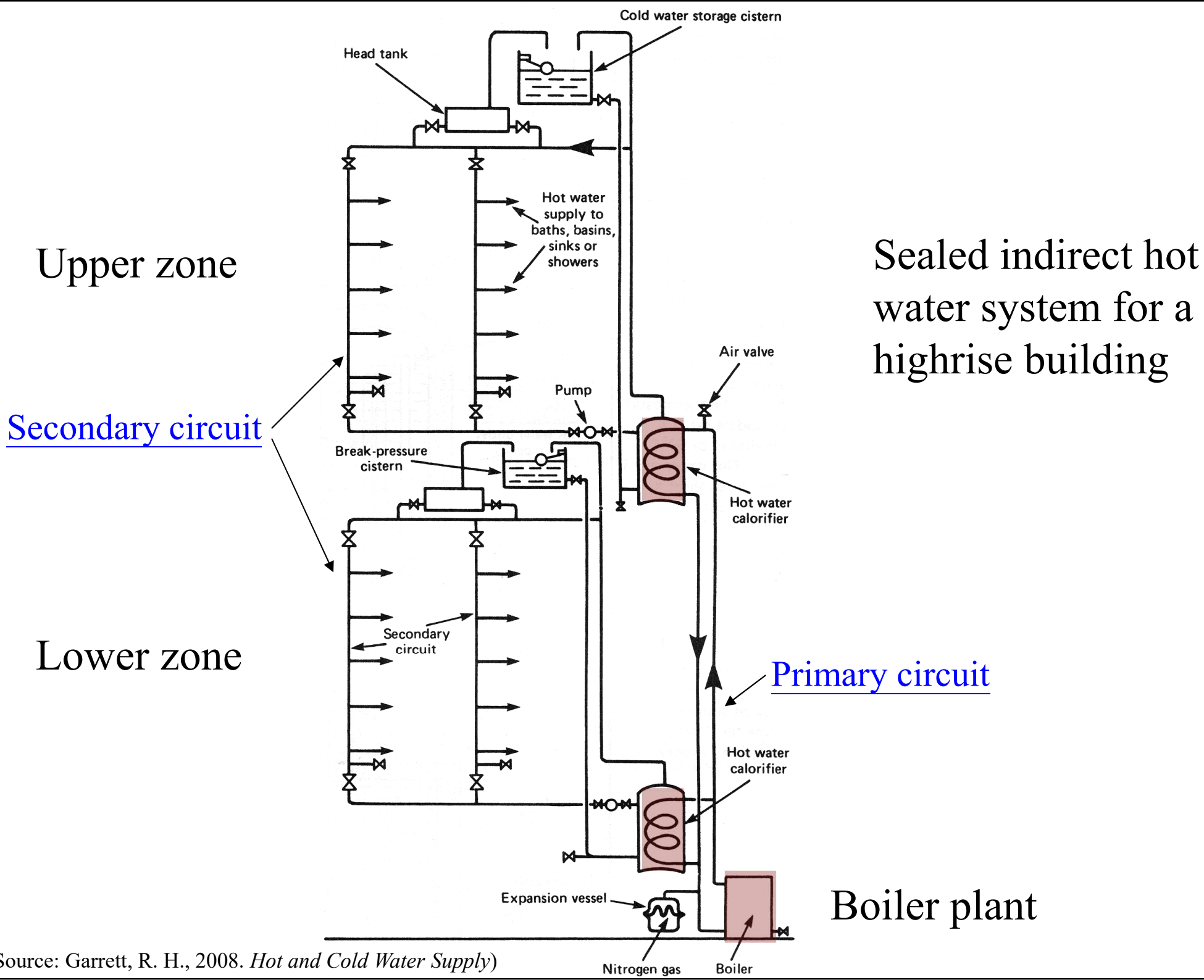

(Source: Garrett, R. H., 2008. *Hot and Cold Water Supply*)

# Centralised hot water systems



- Prevent dead legs in hot water systems
  - ‘Dead legs’ occur in hot water systems where water does not move for a period of time
    - Such as at night when hot water is not used and the contents of the pipes and appliances cools down
  - Water cooled to 20 to 45 °C becomes more susceptible to bacteria growth, and overnight gives adequate time for possible bacteria to multiply
  - Two common approaches to avoid dead legs:
    - 1. Install a secondary return pipe
    - 2. Maintain the water temperature at all times



# Design practice in Hong Kong

- Types of systems:
  - Non-centralised hot water systems
  - Centralised hot water systems
- Safety and statutory requirements
  - Hong Kong Waterworks Standard Requirements for Plumbing Installation in Buildings (HKWSR)
  - Gas safety (by EMSD) e.g. GU mark
  - Electricity safety (by EMSD)
  - Boilers & pressure vessels (by Labour Dept.)

## Requirements for non-centralised hot water systems

<b>Type of water heater</b>	<b>Requirements for direct connection (without storage tank) to supply pipe</b>
Non-pressure type heaters Cistern type water heaters Instantaneous water heaters	The factory test pressure of the heater is in excess of 1.5 times the maximum static pressure at the water mains supply point
Unvented electrical thermal storage water heaters	HKWSR Clause 5.11 and with safety devices complying with Electrical Products (Safety) Regulation
Pressure type thermal storage heaters other than unvented heaters	Storage tank is required in all cases with a vented pipe

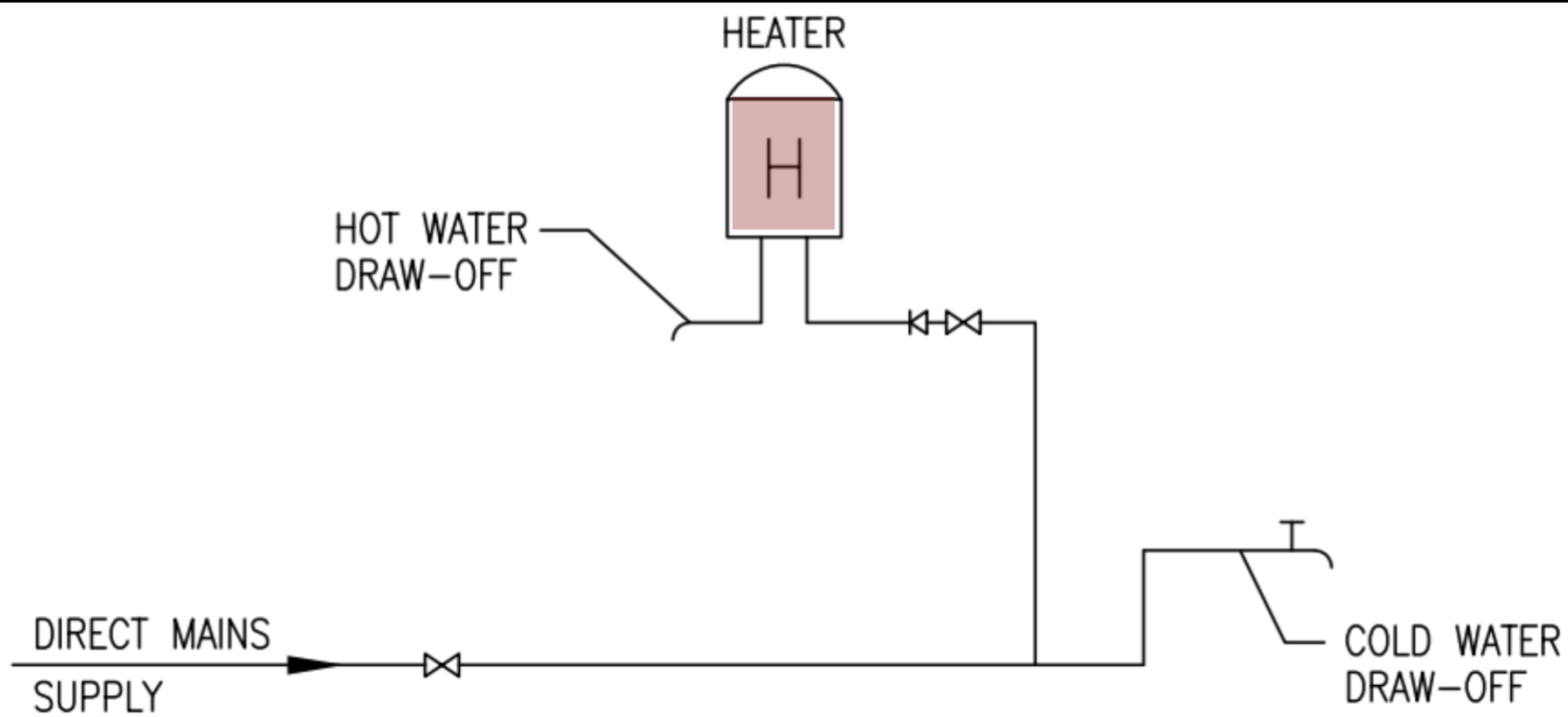

Non-pressure  
type heater

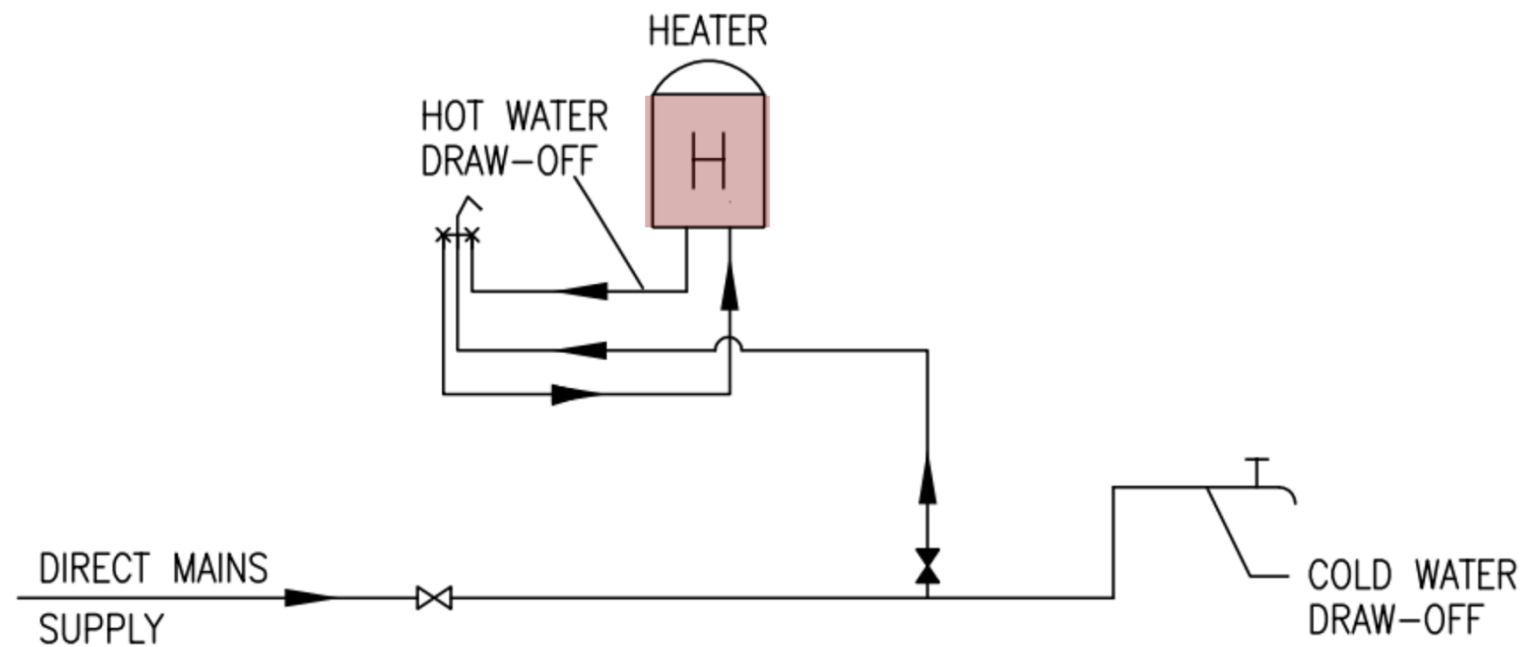

Non-pressure  
type heater  
with loose  
jumper type  
stopcock

(Source: WSD, 2020. *Technical Requirements for Plumbing Works in Buildings (November 2020 version)*, Water Supplies Department (WSD), Hong Kong. <https://www.wsd.gov.hk/en/plumbing-engineering/requirements-for-plumbing-installation/technical-requirements-for-plumbing-works-in-bldgs/>)

# Cistern type water heater

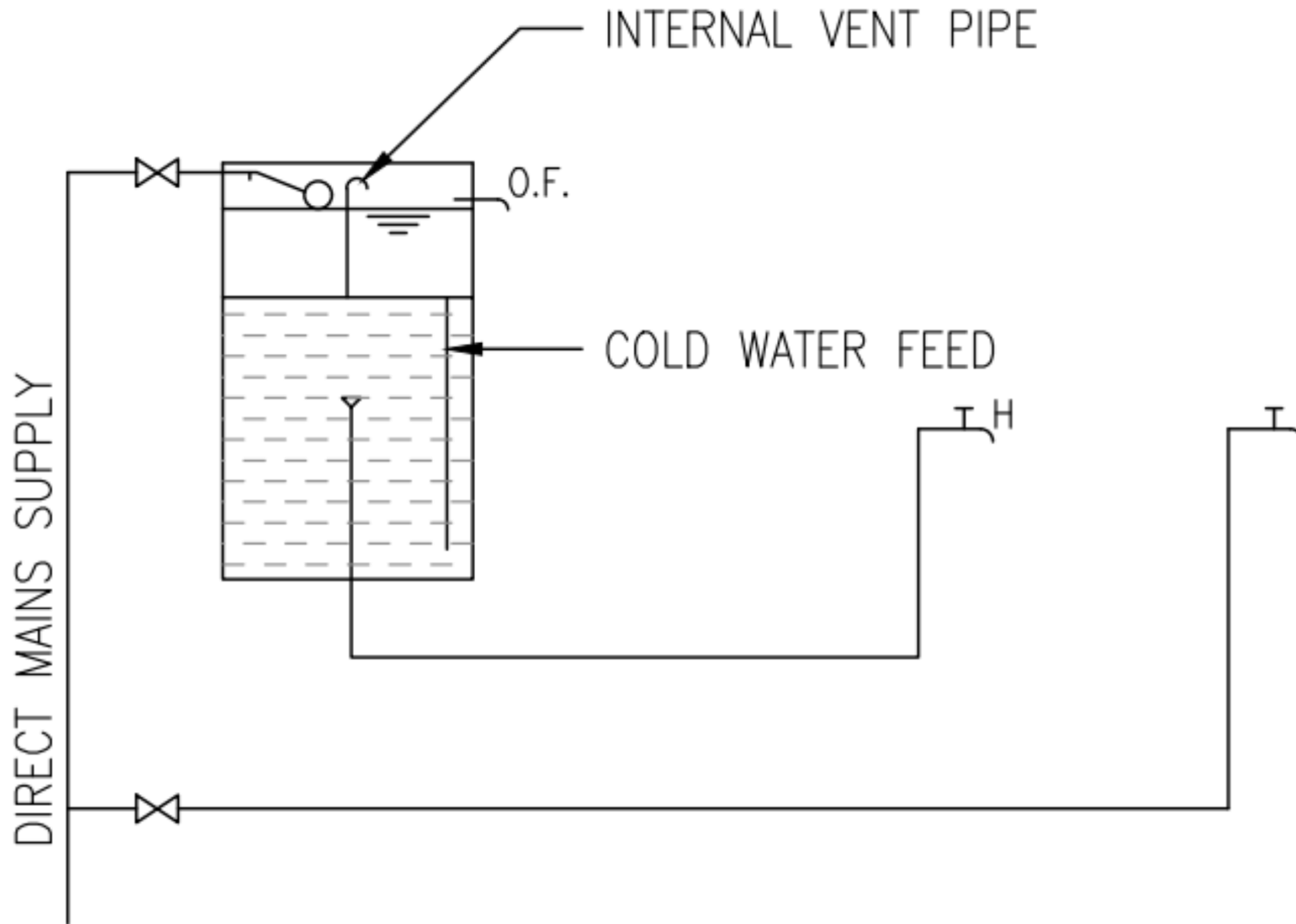

(Source: WSD, 2020. *Technical Requirements for Plumbing Works in Buildings (November 2020 version)*, Water Supplies Department (WSD), Hong Kong. <https://www.wsd.gov.hk/en/plumbing-engineering/requirements-for-plumbing-installation/technical-requirements-for-plumbing-works-in-bldgs/>)

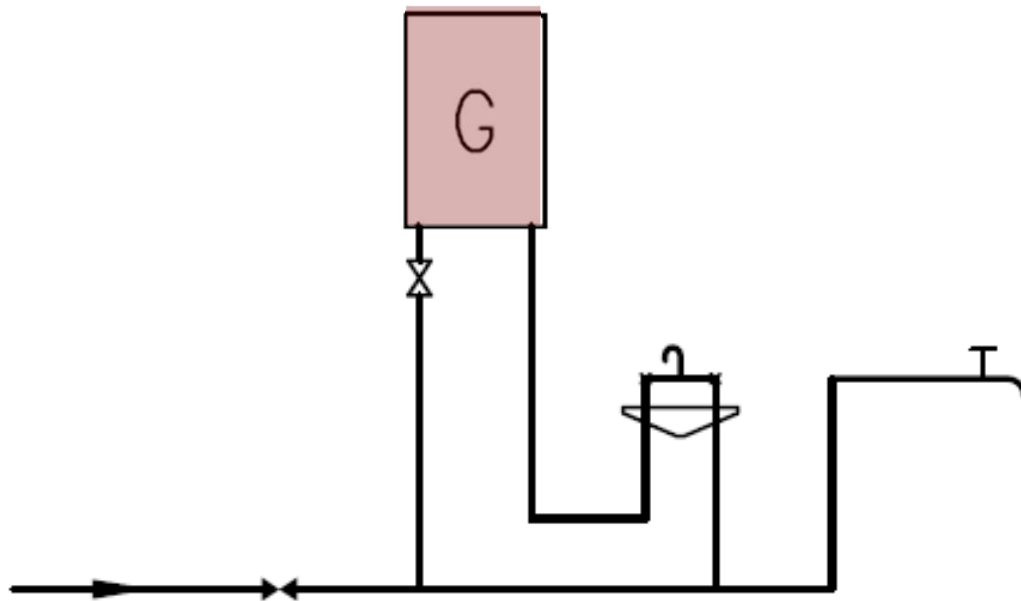

Instantaneous  
gas water  
heater  
connected  
directly to  
mains supply

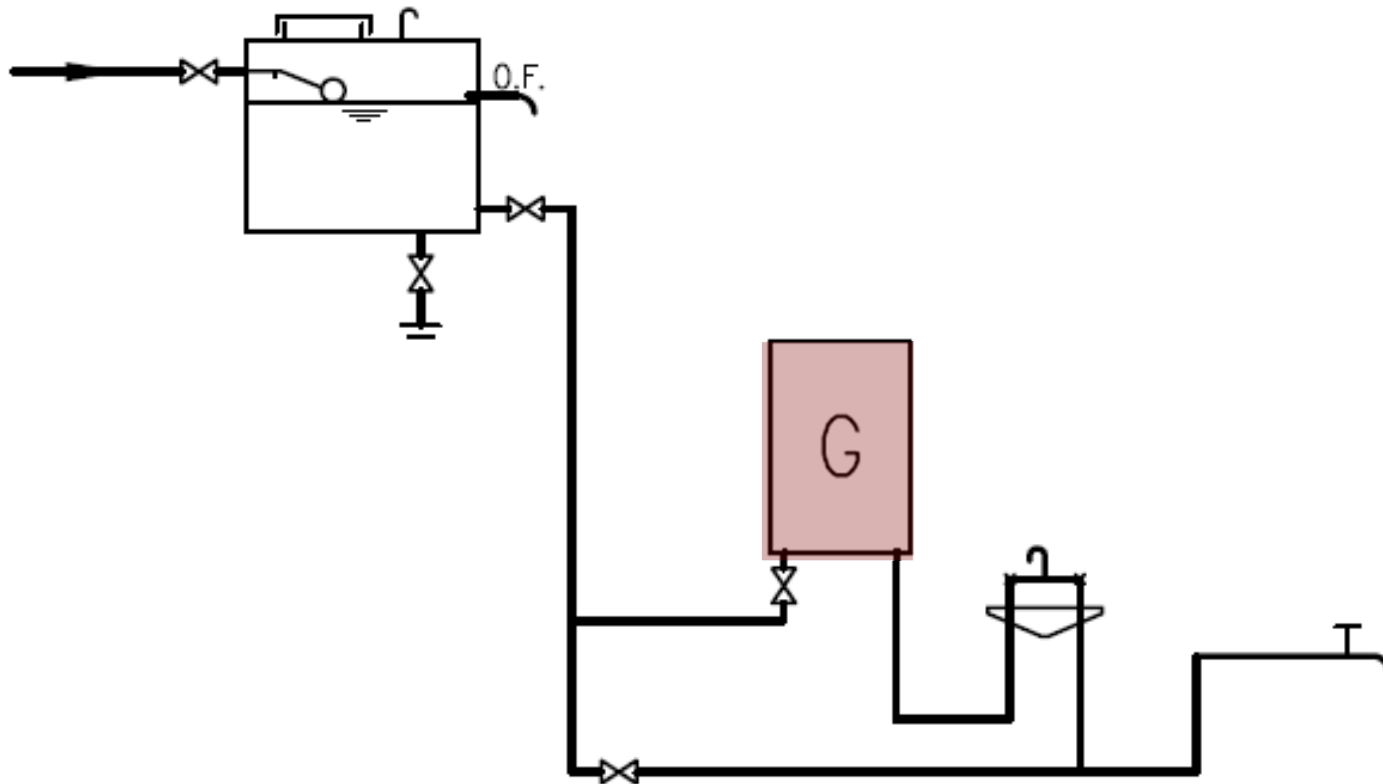

Instantaneous  
gas water  
heater  
connected  
indirectly to  
mains supply



# Design practice in Hong Kong

- Unvented electric water heater of storage type (HKWSR Clause 5.11):
  - A supply pipe that branches off from the feed pipe at a point above the top of the water heater, or some other device to prevent the water from draining down from the water heater if the source of water supply fails
  - An anti-vacuum valve complying with BS 6282 or some other device to prevent heated water from being syphoned back to the supply pipe
  - A vessel to accommodate expansion of heated water where that expansion is constrained by a non-return valve or some other device, at the inlet of the water heater

(See also: Safety Tips for Using Electric Water Heaters (EMSD))

[https://www.emsd.gov.hk/en/electricity\\_safety/publications/guidance\\_notes\\_guidelines/safety\\_tips\\_for\\_using\\_electric\\_water\\_heaters/](https://www.emsd.gov.hk/en/electricity_safety/publications/guidance_notes_guidelines/safety_tips_for_using_electric_water_heaters/)



# Unvented electric thermal storage type water heater

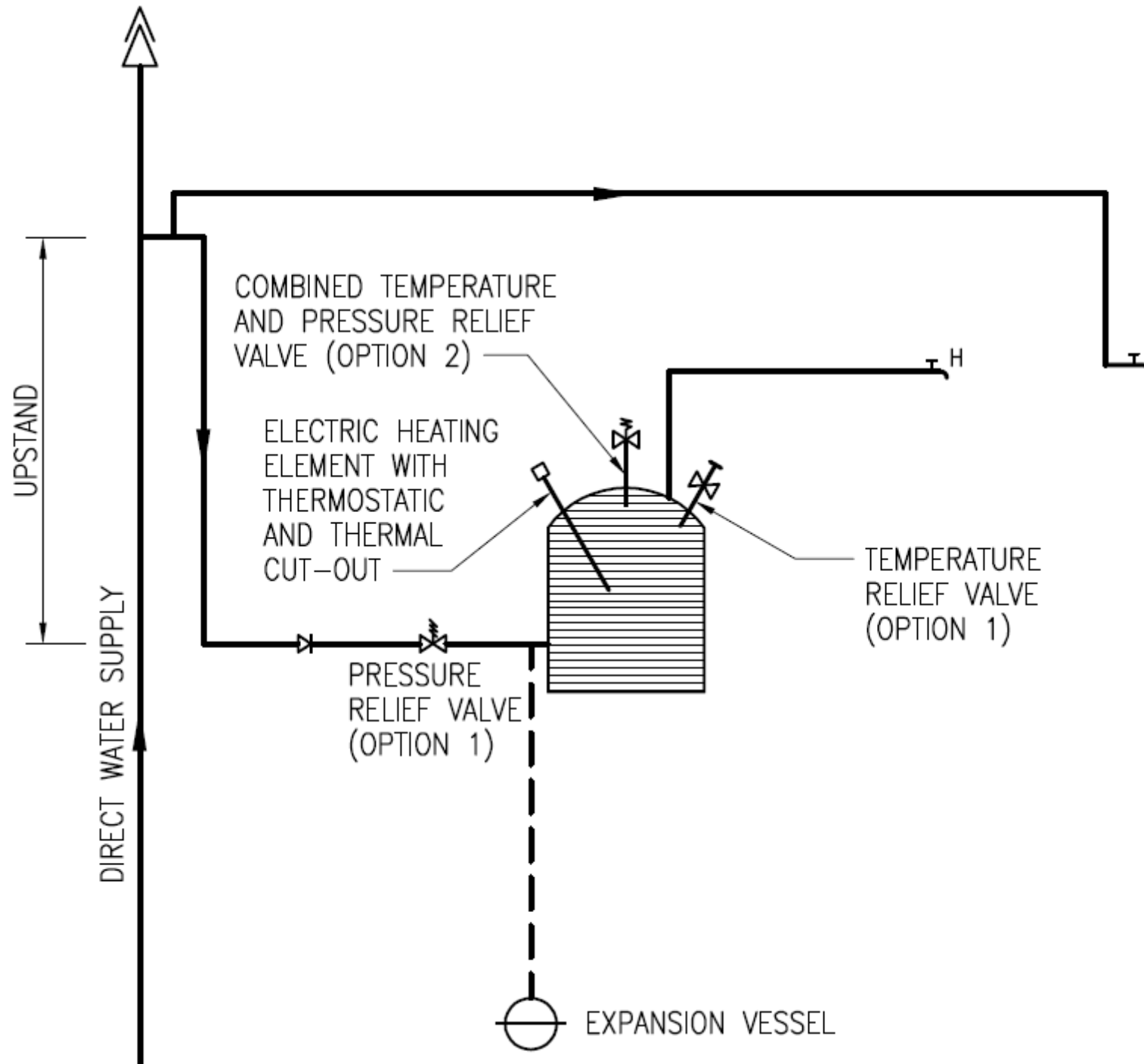

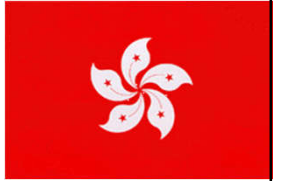

# Design practice in Hong Kong

- Pressure type thermal storage water heater:
  - Supplied from a separate water storage cistern, except these are installed in flats supplied through indirect or sump and pump system
  - A vent or an expansion pipe taken from its highest point and discharge in the atmosphere above the storage cistern at sufficient height to prevent a constant outflow of hot water

# Pressure type thermal storage water heater

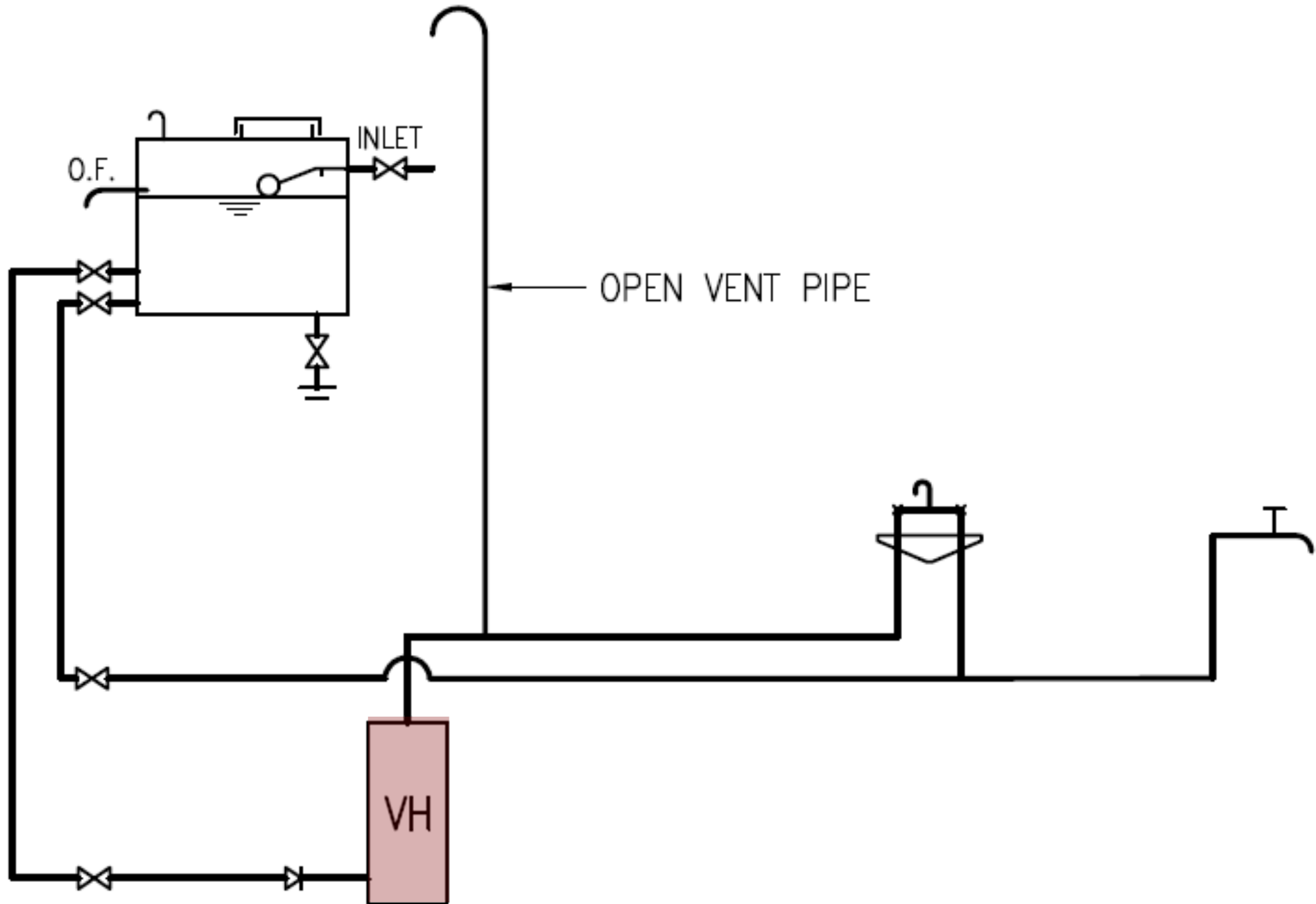

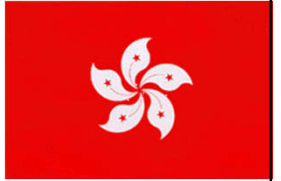

# Design practice in Hong Kong

- Requirements for non-centralised systems
  - Minimum pressure & flow for proper functioning
  - Mixing valves, water blenders or combination fittings (provide a balanced pressure)
  - Electricity (Wiring) Regulations
  - Electric Products (Safety) Regulations
  - Relief valves and drain pipe
  - Max. hot water pipe length

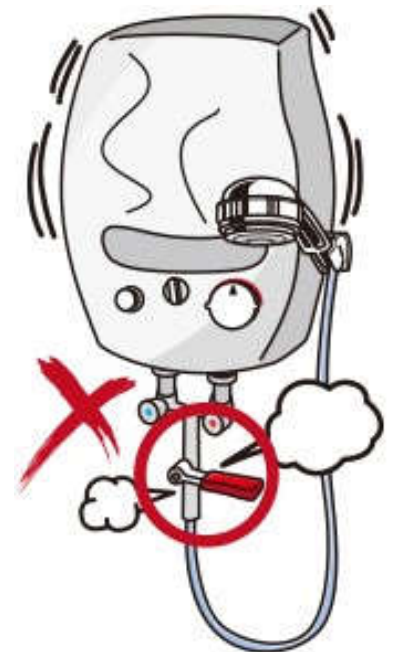

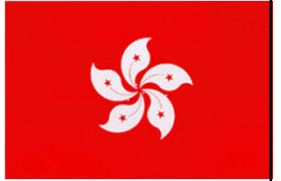

# Design practice in Hong Kong

- Maximum hot water pipe length: (for non-centralised or local systems)

Pipe size diameter	Max. distance between water tap from hot water apparatus
< or = 20 mm	12 m
= 25 mm	8 m
> 25 mm	3 m

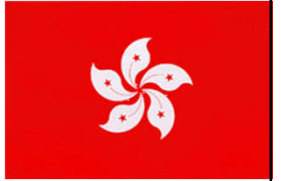

# Design practice in Hong Kong

- Requirements for centralised systems
  - Vent or an expansion pipe from the highest point
  - Safety valve or pressure relief valve
  - Mixing valves, water blenders or combination fittings (provide a balanced pressure)
  - Draining down or emptying the system
  - Avoid waste of water



# Further Reading

- Water heating - Wikipedia  
[https://en.wikipedia.org/wiki/Water\\_heating](https://en.wikipedia.org/wiki/Water_heating)
- Domestic Hot Water Service Systems - Design Procedure  
[https://www.engineeringtoolbox.com/design-hot-water-system-d\\_92.html](https://www.engineeringtoolbox.com/design-hot-water-system-d_92.html)
- Solar Water Heating  
[https://re.emsd.gov.hk/english/solar/solar\\_wh/solar\\_wh\\_to.html](https://re.emsd.gov.hk/english/solar/solar_wh/solar_wh_to.html)
- Solar Water Heating - Application Considerations  
[https://re.emsd.gov.hk/english/solar/solar\\_wh/solar\\_wh\\_ac.html](https://re.emsd.gov.hk/english/solar/solar_wh/solar_wh_ac.html)

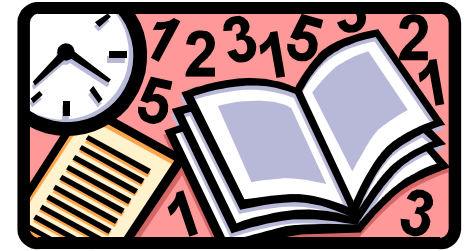

# References

- Garrett, R. H., 2008. *Hot and Cold Water Supply*, 3rd ed., Chichester, West Sussex, U.K.
- WSD, 2021. Technical Requirements for Plumbing Works in Buildings (December 2021 version), Water Supplies Department (WSD), Hong Kong. <https://www.wsd.gov.hk/en/plumbing-engineering/requirements-for-plumbing-installation/technical-requirements-for-plumbing-works-in-bldgs/>
- WSD, 2018. *Handbook on Plumbing Installation for Buildings*, Water Supplies Department (WSD), Hong Kong. <https://www.wsd.gov.hk/en/plumbing-engineering/requirements-for-plumbing-installation/handbook-on-plumbing-installation/>
- WSD, 2017. *Hong Kong Waterworks Standard Requirements for Plumbing Installation in Buildings*, Water Supplies Department (WSD), Hong Kong. <https://www.wsd.gov.hk/en/plumbing-engineering/requirements-for-plumbing-installation/previiously-used-documents-hkwsr-hpi/>