

## Daylighting Design

*Ir Dr. Sam C. M. Hui*

E-mail: [sam.cmhui@gmail.com](mailto:sam.cmhui@gmail.com)

<http://ibse.hk/cmhui/>

# Contents



- Daylight benefits
- Circadian lighting
- Design principles
- Daylighting methods
- Shading and controls





# Daylight benefits

- Well-planned, imaginative use of daylight will strengthen the character of a building & enhance the architectural design
  - It also has a positive effect on the physical & psychological well-being (e.g. light therapy)
- Existing daylight conditions depend on
  - Building's orientation, location & surroundings
- Also, daylight has a significant effect on landscape & urban spaces



# Daylight benefits

- Daylight as a **building material**
  - It is celebrated in architecture
    - To create & dissolve space
    - To shape an uncontroled space in an almost material way to turn an instant into an intense experience
    - To create ambience & movement to articulate the space
  - Examples of techniques
    - Light reflex
    - Intersecting light
    - Sidelight

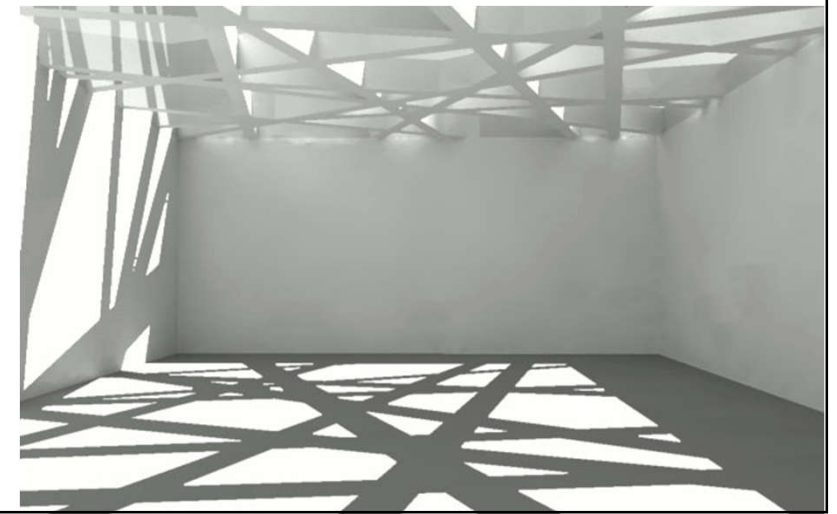

# The power of daylight design

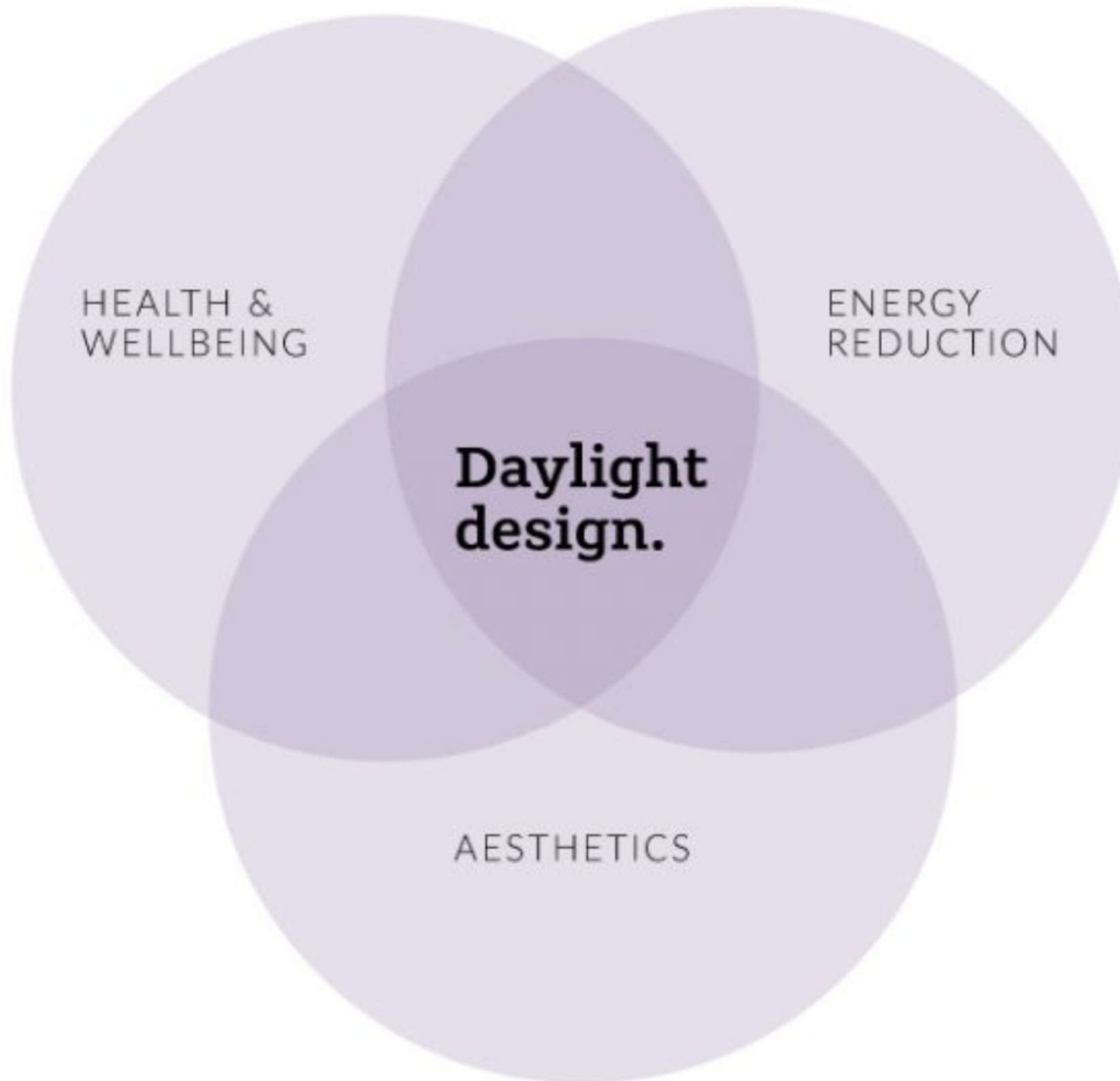

# Examples of daylight design in buildings



(Source: <https://hoarelea.com/2018/09/07/the-power-of-daylight-design/>)



# Daylight benefits

- Natural light varies throughout the day & can give us the right amounts of many spectral lights to keeping our health system balance
  - Windowless environments can affect our sleep quality (circadian rhythms), concentration, performance & productivity
  - Natural light (sunlight) influences our quality of life: we sleep better & longer when we have access to daylight, and this has impact on our physical energy, cognitive performance & mood



# Daylight benefits

- People prefer environments with windows, daylight as well as an access to a pleasant view, particularly nature
  - The result is a higher level of satisfaction, the increase of the sense of health & wellbeing, which are the perfect ingredients for a better productivity, less absenteeism & presentism
  - People who spend more time outdoors have more vitality (sunlight promotes vitamin D production)



# Benefits of daylighting design



## **Workplaces & Offices**

Improve efficiency & concentration, and thus increase productivity



## **Educational Organizations**

Improve motivation & engagement with teachers & students at school

# Benefits of daylighting design



## Hospitals & Nursing Homes

Unwind & calm patients with light, which also helps them to sleep better & heal faster



## Fitness & Wellness Centres

Energize for active work-outs



# Daylight benefits

- Daylight & well-being
  - Psychological effects of daylight
    - Prevention of Seasonal Affective Disorder (SAD)
  - Photobiological processes of human eye & skin
  - The dynamics of daylight has a stimulating effect
- Qualities of daylight
  - Brightness
  - Colour & the spectral composition
  - Light direction
  - Time duration





# Daylight benefits

- The non-visual systems (ipRGC) are mostly sensitive to short-wavelength light (blue light) and have impacts on alertness, performance & circadian rhythms by the regulation of sleep-wake cycle & hormonal processes on our mood & emotions
- Viewing nature is one of the countermeasures that could minimize the negative effect of bright light

(ipRGCs = Intrinsically Photosensitive Retinal Ganglion Cells)

# Circadian lighting



- Human beings have evolved over millions of years with the sun & our ipRGCs are more sensitive to light that hits the bottom of the back of our eyes
- In our built environment, most of our lighting is directly overhead for the entire day, and is not optimized to impact our circadian rhythm, even at high intensities
  - Optimal circadian stimulus is beneficial to health

# Circadian lighting



- Circadian lighting 自然光韻律系統
  - Minimize negative effects of electric light on the human circadian rhythm (a 24-hour internal clock)
    - The hypothalamus (下丘腦) in the brain receives signals from the eyes and controls the amount of melatonin (褪黑素) released to correlate sleepiness with darkness & alertness with lightness
  - Affect people's health, alertness & productivity
  - Three approaches: intensity tuning, colour tuning, and stimulus tuning



# Production of the hormones melatonin & cortisol during 24-hour daily

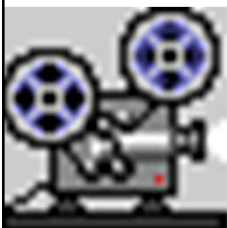
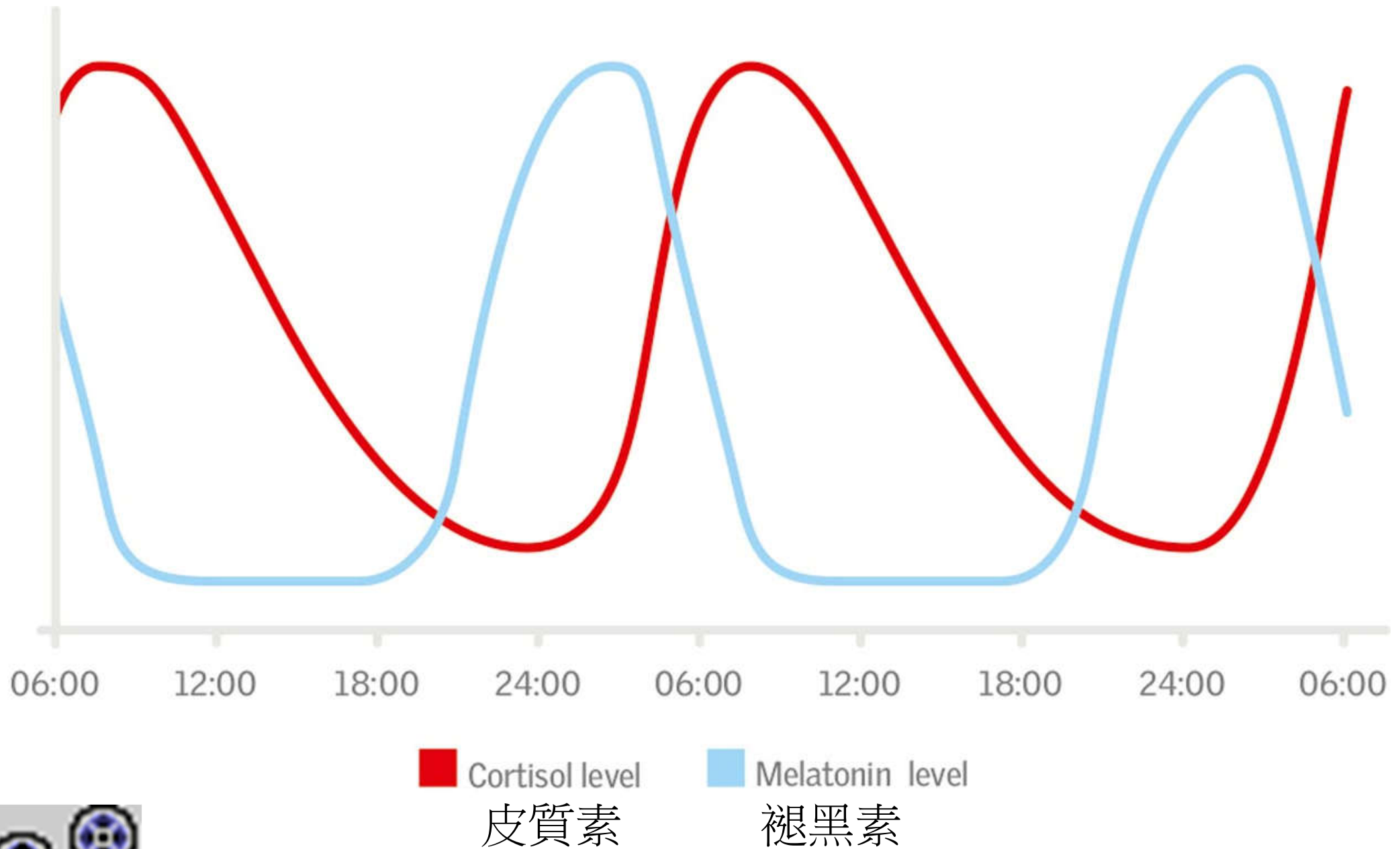

Video: SMUD: What is Circadian Lighting? (3:05) <https://youtu.be/arm-QRAwNc4>

(Source: <https://www.velux.com/what-we-do/research-and-knowledge/deic-basic-book/daylight/daylighting-quality>)

# Lighting impacts on circadian rhythms

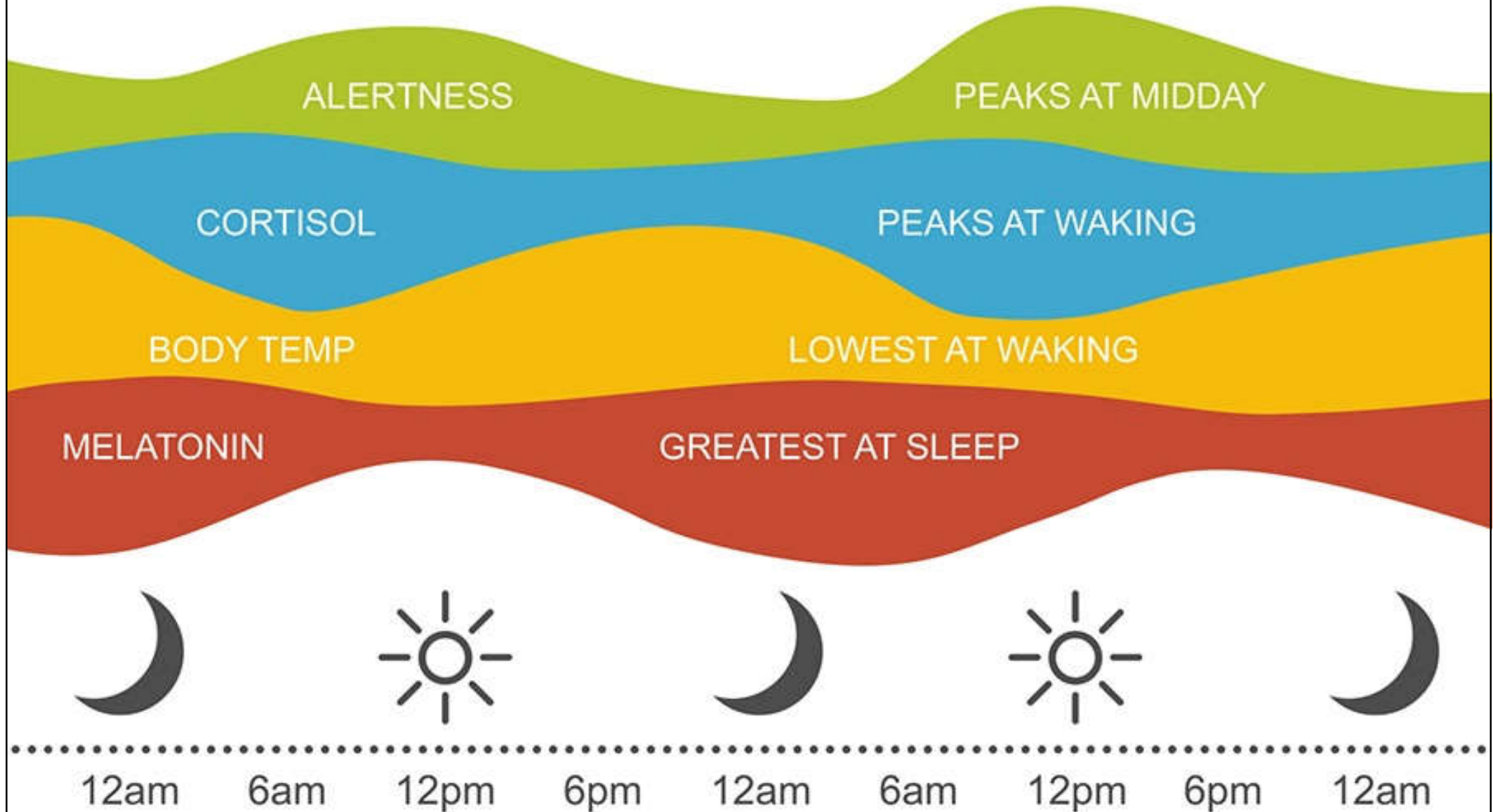



## Normal circadian sleep rhythm

Sleep urge (circadian biological clock) is greatest at night with a small increase at mid-day. Sleep need (sleep homeostasis) increases throughout the waking hours and is replenished during sleep

### Typical daily rhythm of the sleep-wake cycle

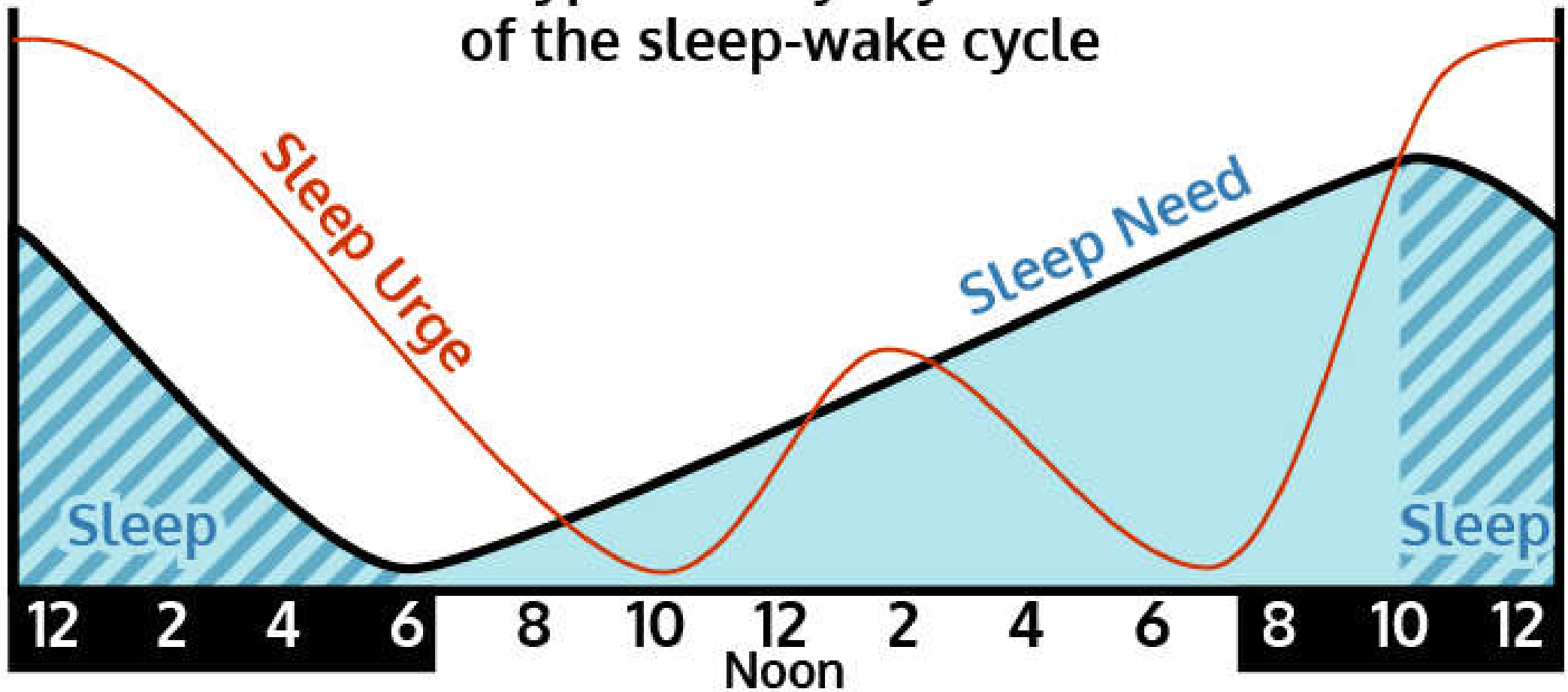

# Circadian lighting



- Circadian lighting methods:
  - 1. Intensity tuning
    - Maintain a fixed correlated colour temperature (CCT) while the light intensity (brightness) is adjusted through a dimming system to correlate with time of day
  - 2. Colour tuning
    - Change the light intensity & CCT to mimic the daytime/night-time cycle
  - 3. Stimulus tuning
    - Replaces the “bad blue” with “good blue” light wavelengths

# Circadian lighting & correlated colour temperature (CCT)

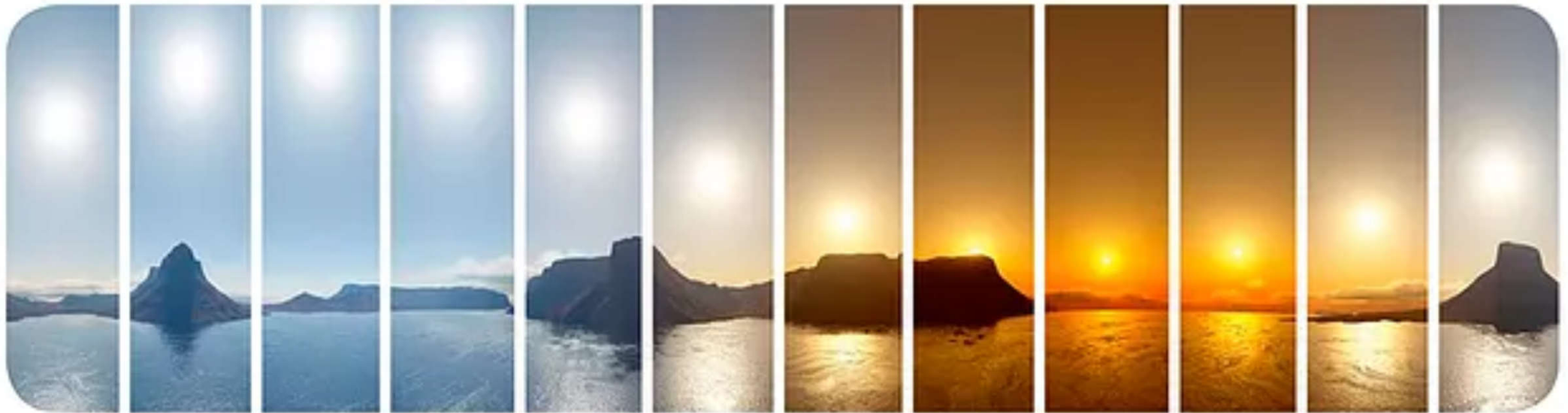

**ENERGY IN THE MORNING**

4000K white + blue-enriched

**HAPPINESS AT MIDDAY**

4000K - 3000K white

**RELAXATION IN THE EVENING**

3000K - 2700K white



(Source: <https://www.lightengine-tech.com/circadian-light-solution>)

# Rhythm of life & circadian disruption

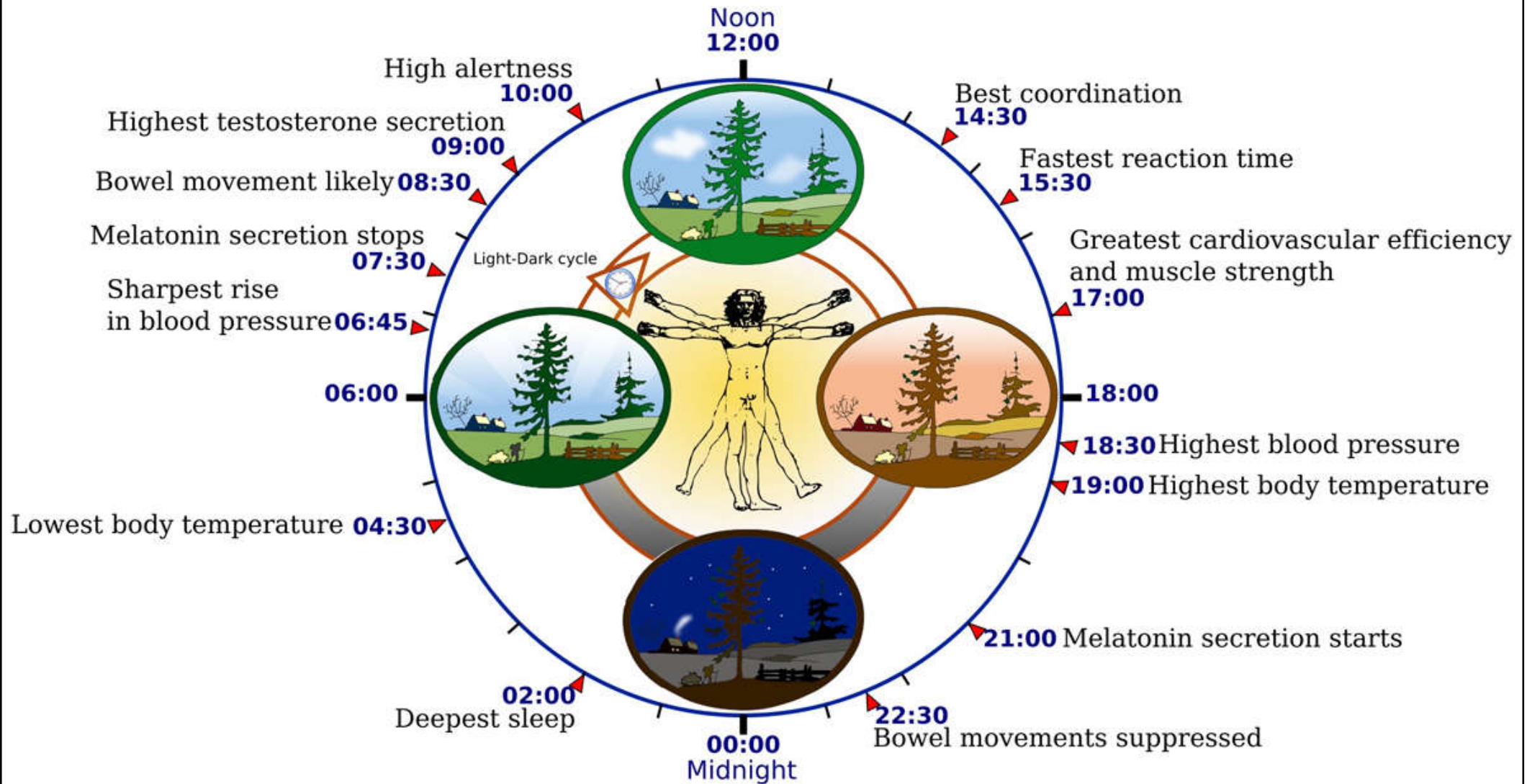

# Example of a dynamic lighting scenario for human-centric lighting in offices (daytime use)

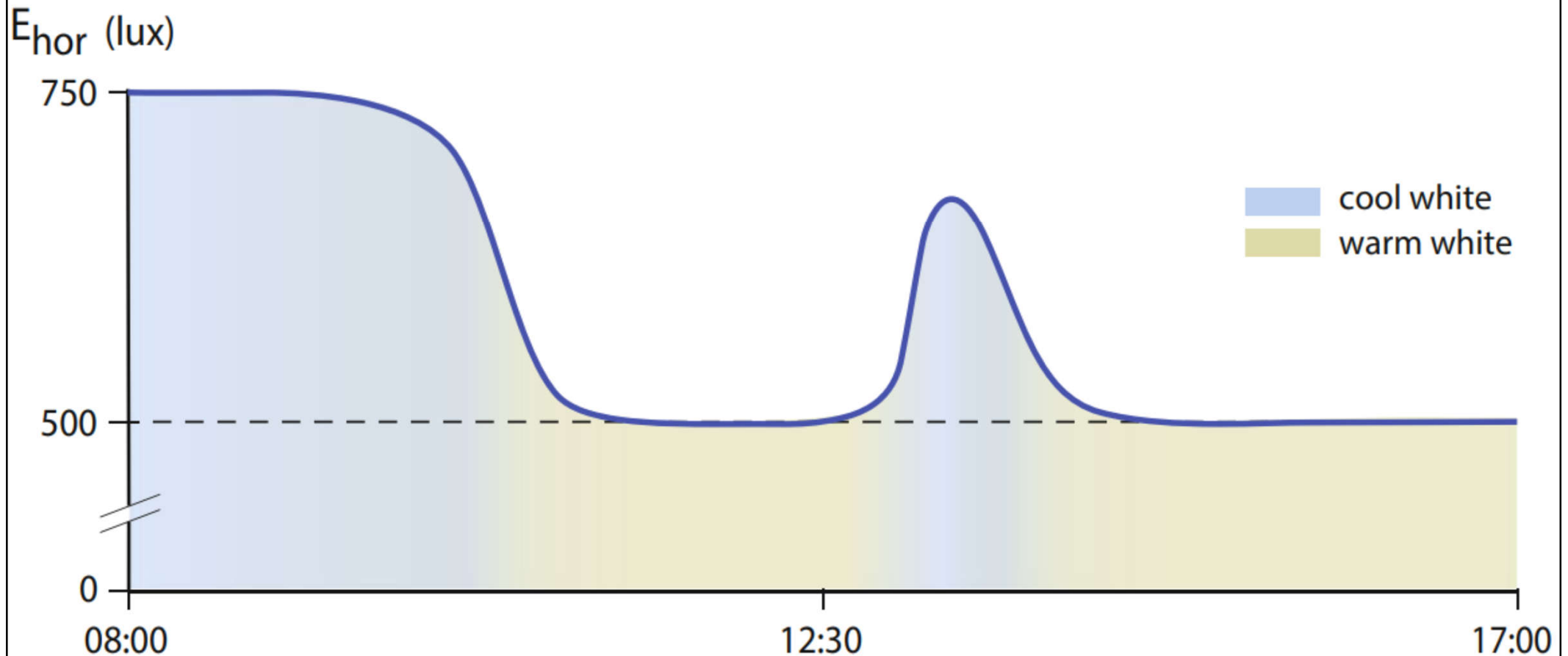

Gradually changing lighting level from 750 to 500 lux (horizontally) and light colour from cool white (approx. 6500 K) to warm white (3000–4000 K) to facilitate both adequate visual & non-visual biological effects (i.e. entrainment of the biological clock, night-time sleep, daytime alertness and performance). The value of 750 lux horizontal illuminance for 6500 K corresponds to roughly 250 lux melanopic equivalent daylight (D65) illuminance. The value of 500 lux for 3000-4000 K corresponds to roughly 85 lux melanopic equivalent (D65) illuminance.

# Circadian lighting



- Circadian lighting design
  - Such as the criteria L03 in the WELL Standard
    - <https://standard.wellcertified.com/light/circadian-lighting-design>
  - To provide users with appropriate light exposure (natural & artificial) to enhance circadian rhythms
  - The effects can be measured in Equivalent Melanopic Lux (EML), a metric that is weighted to the ipRGCs instead of to the cones
    - $EML = \text{Visual lux (L)} \times \text{Melanopic ratio (R)}$

# Melanopic Ratio by Light Source

---

CCT (K)	Light Source	Ratio
2700	LED	0.45
3000	Fluorescent	0.45
2800	Incandescent	0.54
4000	Fluorescent	0.58
4000	LED	0.76
5450	CIE E (Equal Energy)	1.00
6500	Fluorescent	1.02
6500	Daylight	1.10
7500	Fluorescent	1.11

---

*\* Source: WELL Building Standard v1*

# Circadian stimulus versus circadian light on melatonin suppression

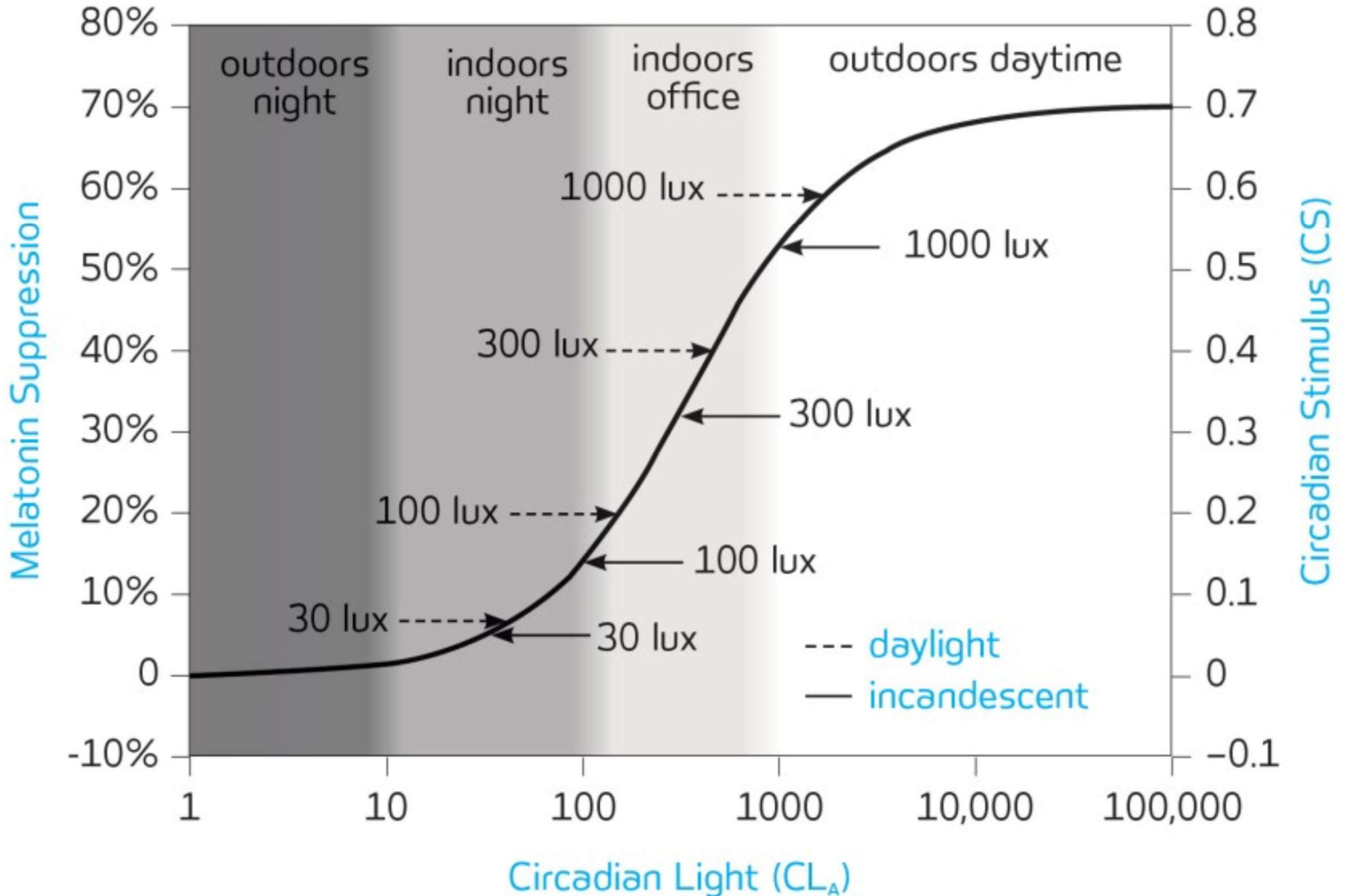



# A workplace circadian lighting design strategy

## Design for Daylight

- Sequential spatial experience
- Access to sunlight
- Flexible shading
- Views out



## Supplement with Electric Light

- Spatial distribution/contrast and visual experience
- Variation
- Activity based



## Control

- Daylight responsive
- Personal control
- User interaction



# Design principles



- Daylighting: controlled use of natural light
  - Placing windows & reflective surfaces so that natural light provides effective internal illumination during the day
  - Successful daylighting requires design considerations at all stages of the building design process, from site planning to architectural, interior & lighting design
  - Components of daylight: (a) direct sunlight, (b) diffuse skylight & (c) reflected light

# The components of daylight

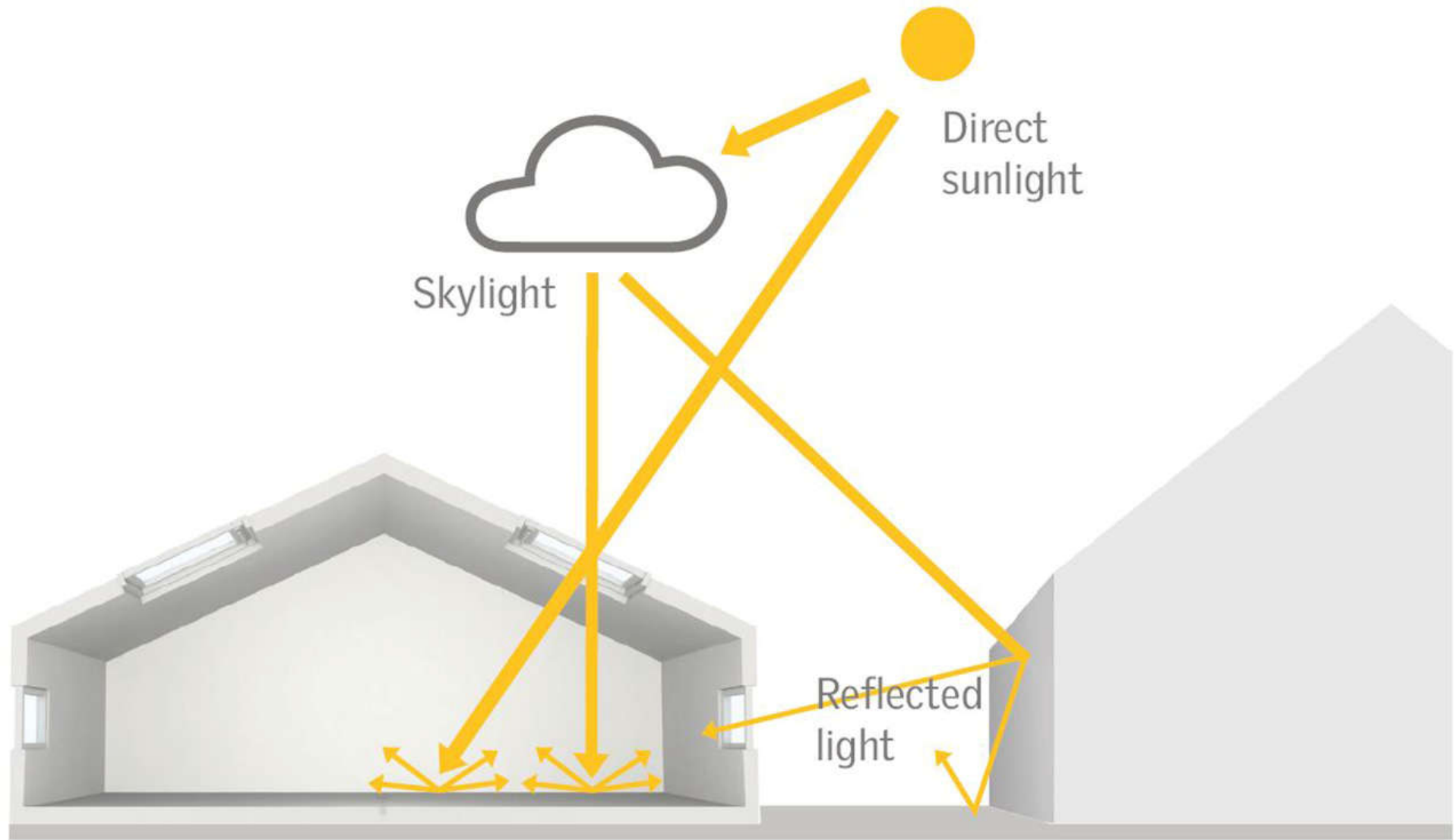

(a) Direct sunlight (bright direct solar radiation)

(b) Diffuse skylight (diffuse light through clouds or partially cloudy skies; overcast sky)

(c) Reflected light (from natural & man made surfaces)

# Components of daylight illumination in buildings

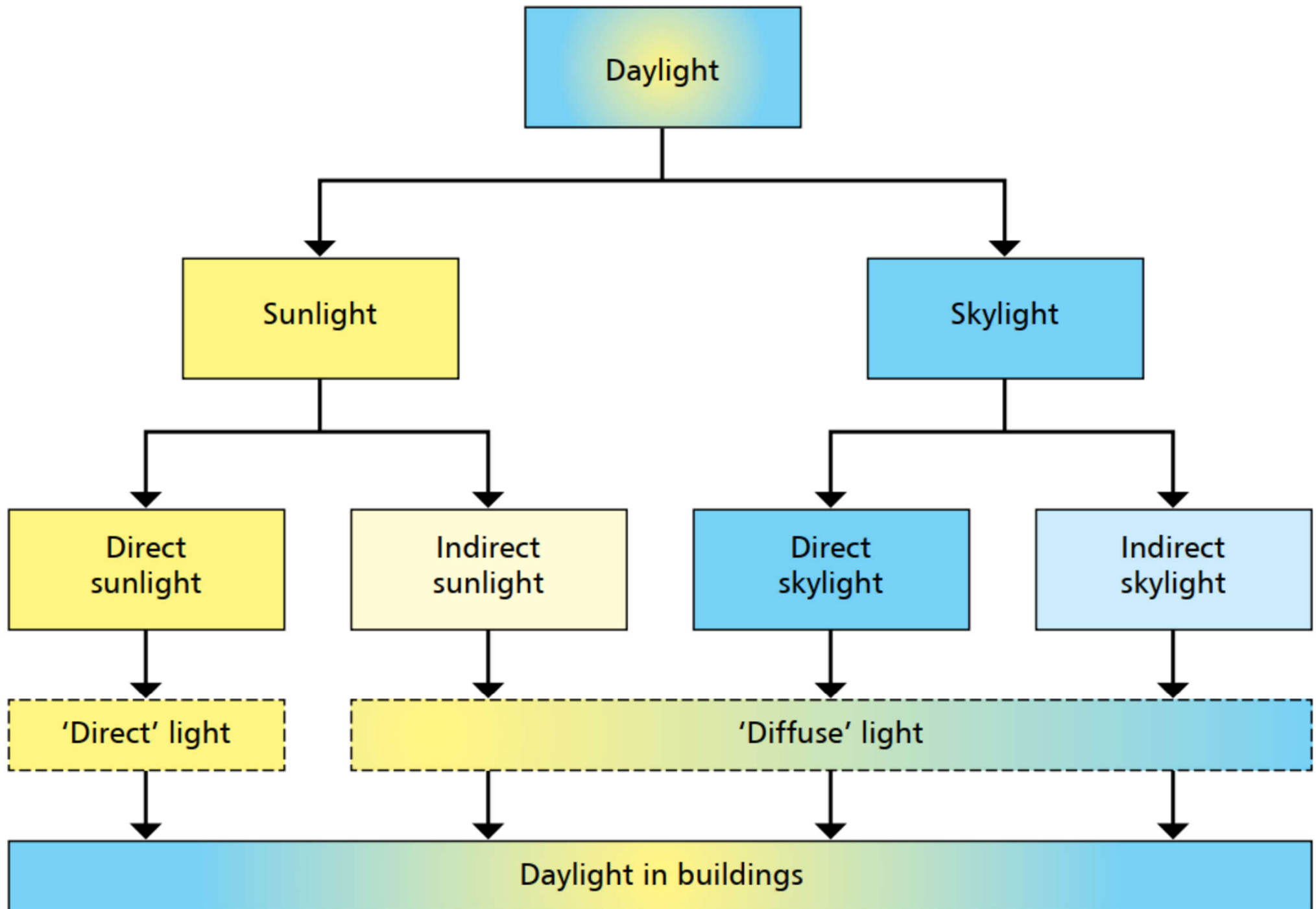

# Electromagnetic spectrum of daylight

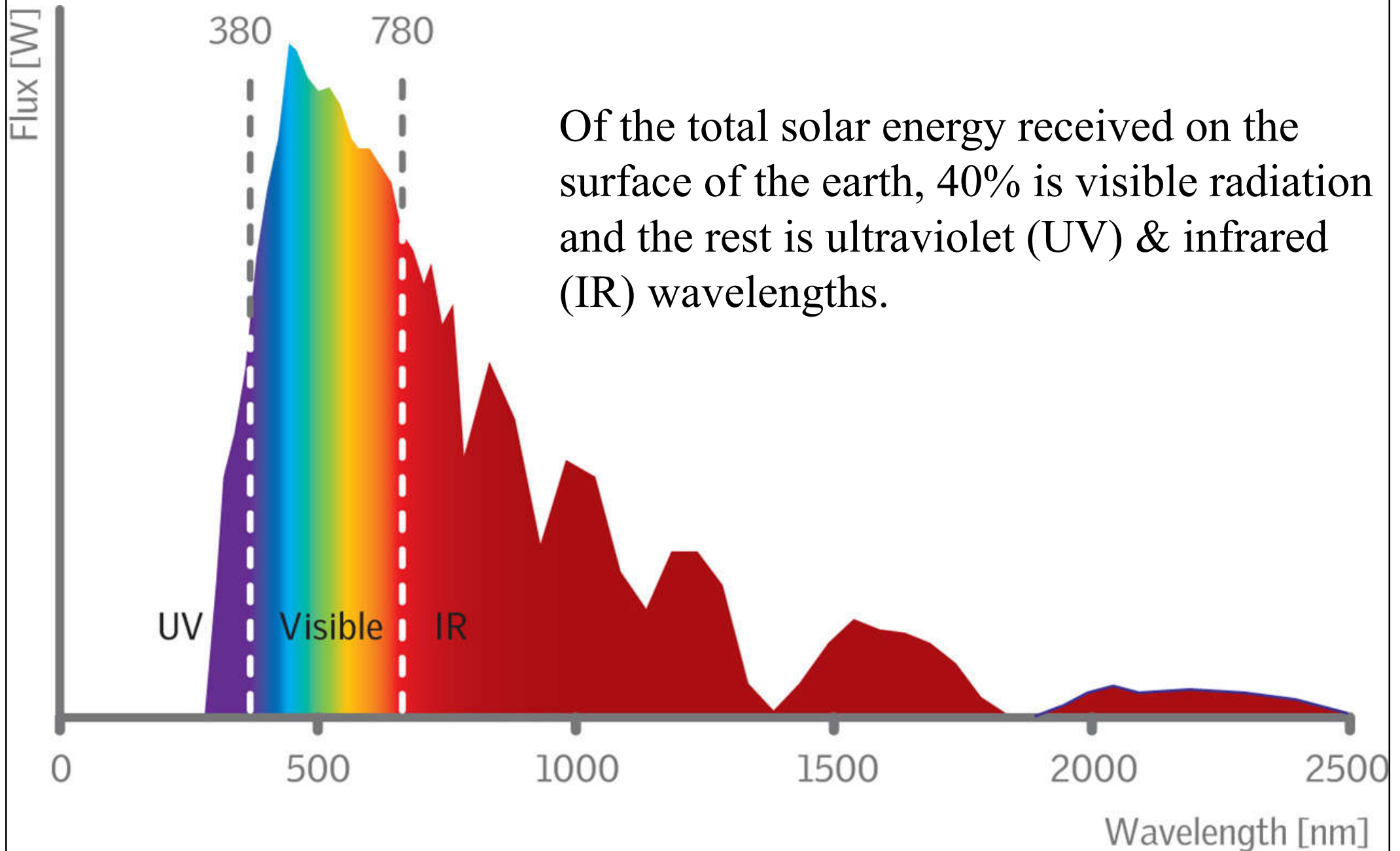

# Design principles



- Daylight is closely dependent on:
  - Weather conditions (blue sky or cloud)
  - Time of the day (morning & afternoon)
  - Geographic location (altitude & latitude)
  - The environment (rural or urban)
  - Building orientation (north, east, south & west)
  - Season (winter, spring, summer & autumn)
- Natural & artificial light are distinct
  - Also, view quality in & out from a window

# Example of daylight variability

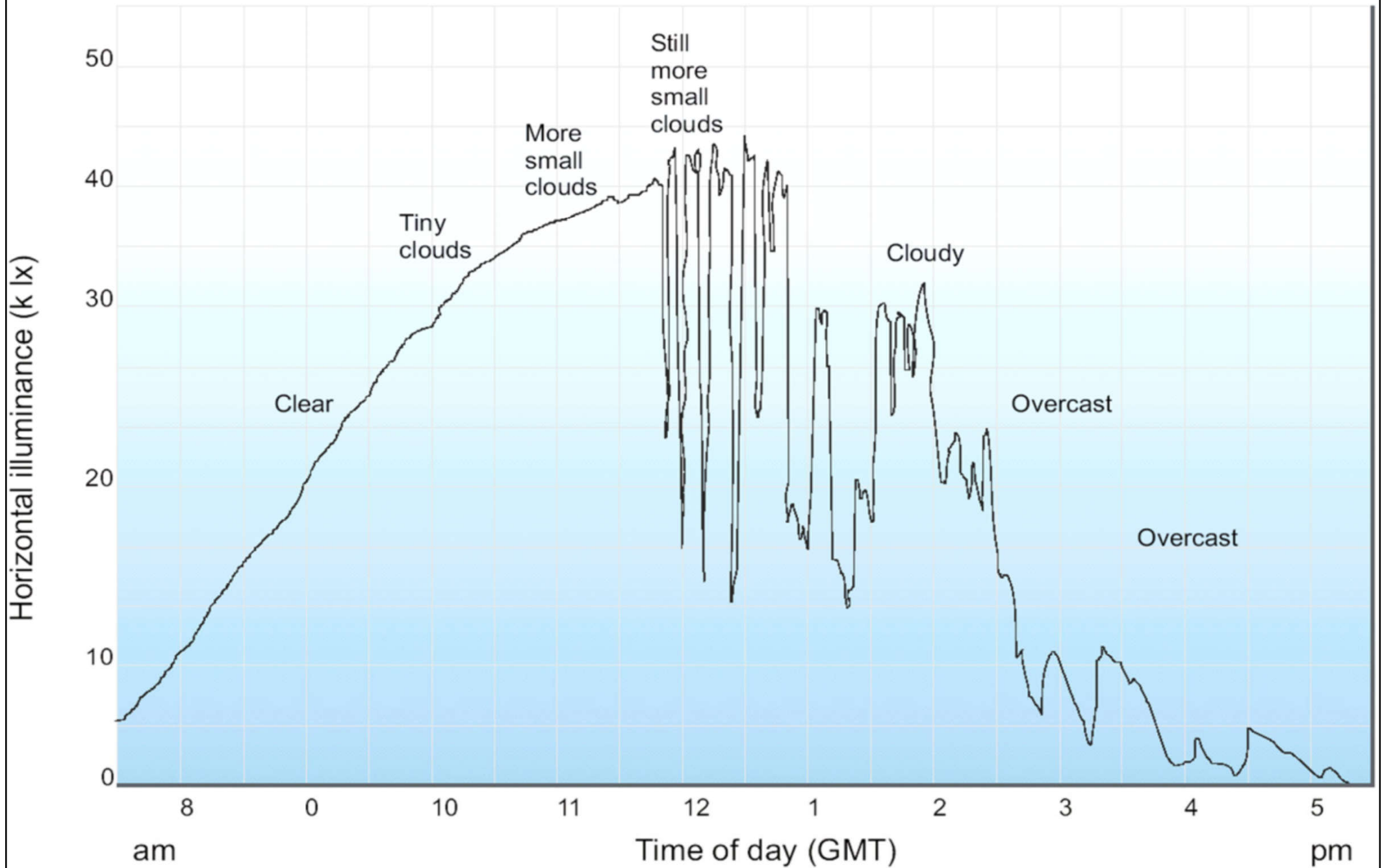

# Sun's paths on the winter solstice (shortest day), the equinox (day & night almost equal) and the summer solstice (longest day)

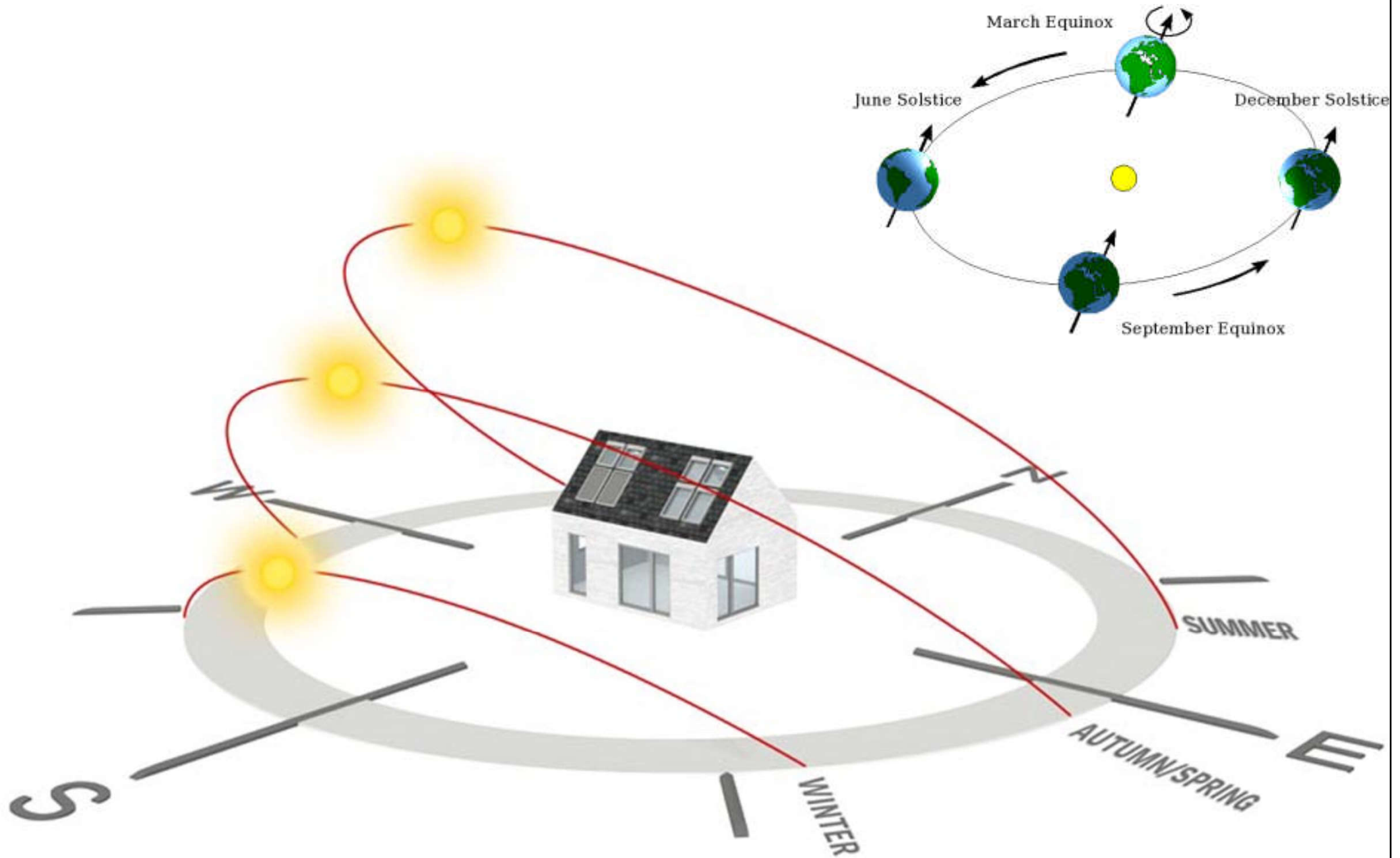



# Common factors to consider in daylight design

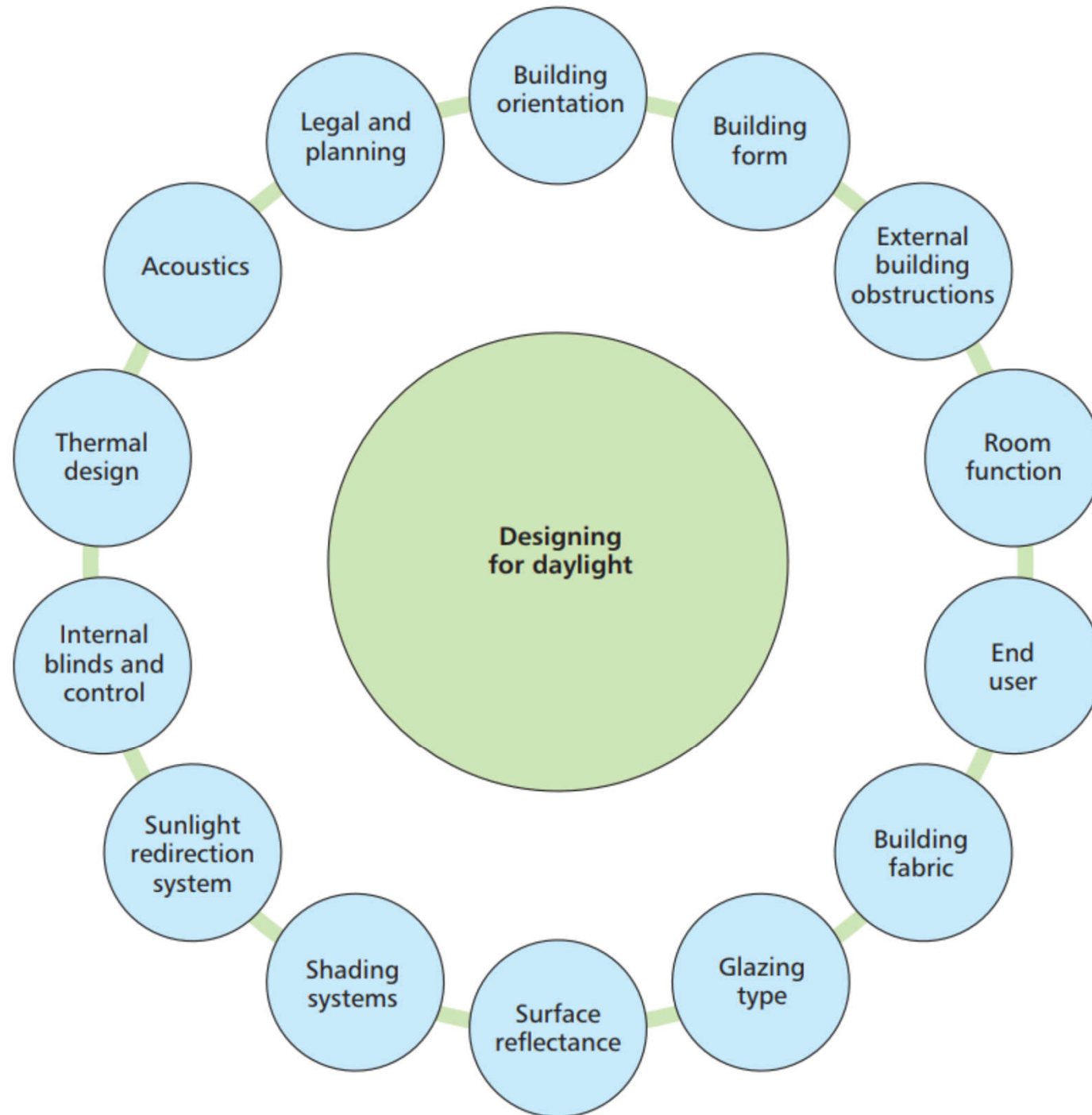

(Source: SLL, 2011. *Lighting for Education*, Lighting Guide 5, Society of Light and Lighting (SLL), London.)

## Properties of daylight & electric light to achieve harmony

<b>Diffuse daylight</b>	<b>Electric light</b>
Cannot be switched on or off, but can be modulated using shading	Can be fully controlled - switched or dimmed
Quantity varies throughout the day & year	Quantity is controllable & predictable
Diffused from large area sources	Can be very focussed/directional, often emitting from small area sources
Direction is usually from the walls (vertical) or roof (horizontal)	Direction can be from any position in the space
Correlated colour temperature (CCT) varies throughout the day & year	CCT is fixed & can be a controlled variable
Colour rendering is 'perfect'	Colour rendering can approach 100 R <sub>a</sub> if desired

# Balancing the costs of windows in daylighting design

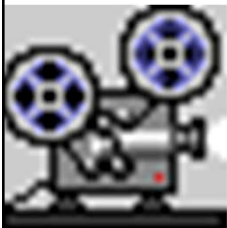
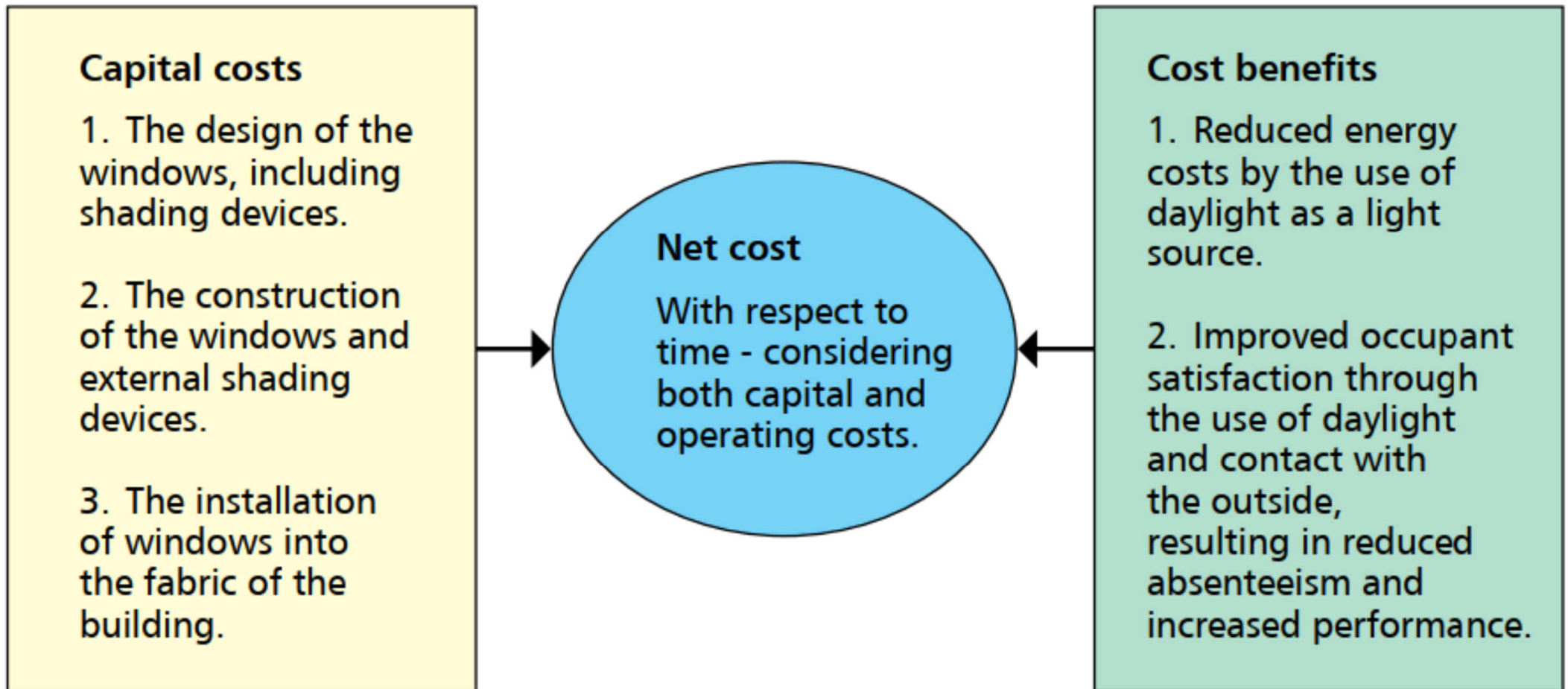

Video: Energy 101: Daylighting (2:43) <https://youtu.be/-7EG4d-W4W8>

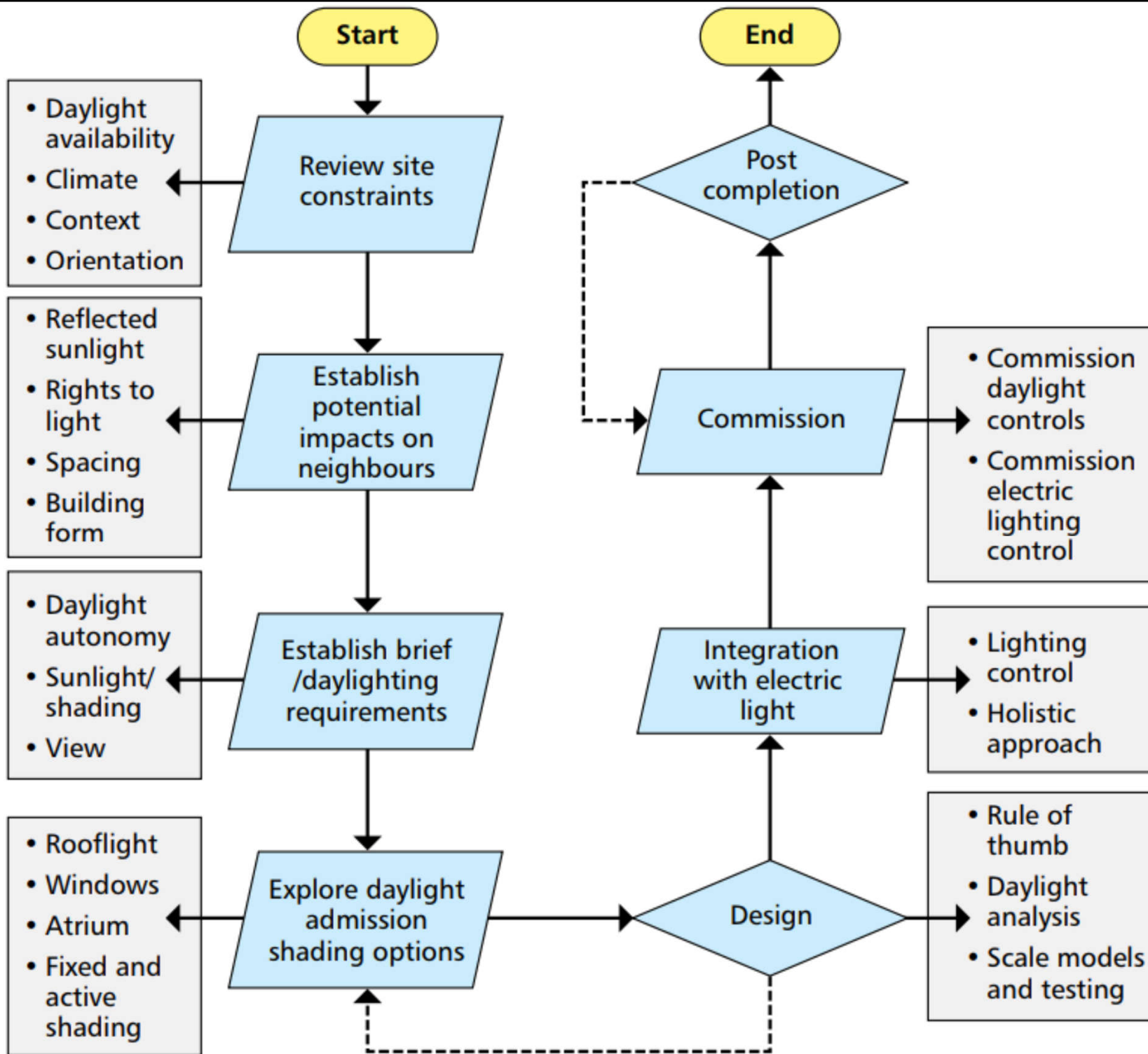

# Daylighting design process

# Daylighting methods



- Methods to harvest & enhance daylight
  - Top lighting – skylights, light pipes
  - Side lighting – windows, curtain wall glazing, light shelves
- Design issues:
  - Depth, shape & orientation of the rooms
  - Colours of the walls, ceiling & floor
  - Colour & finish of the furniture
  - Problems related to heat gain & glare

# Three basic forms for admitting natural light into a space: side lighting, top lighting or atria



Sidelighting



Toplighting



Atria

Views of nature and people	Glare potential	Depth of light penetration	Height limitations
Yes	High	Limited by ceiling height	None
No (limited)	Low	Excellent (uniform distribution)	Yes (single story only)
Yes	Low	Excellent (Limited by aspect ratio of atria)	None

# Toplighting with glazing tilt to match the seasonal lighting needs

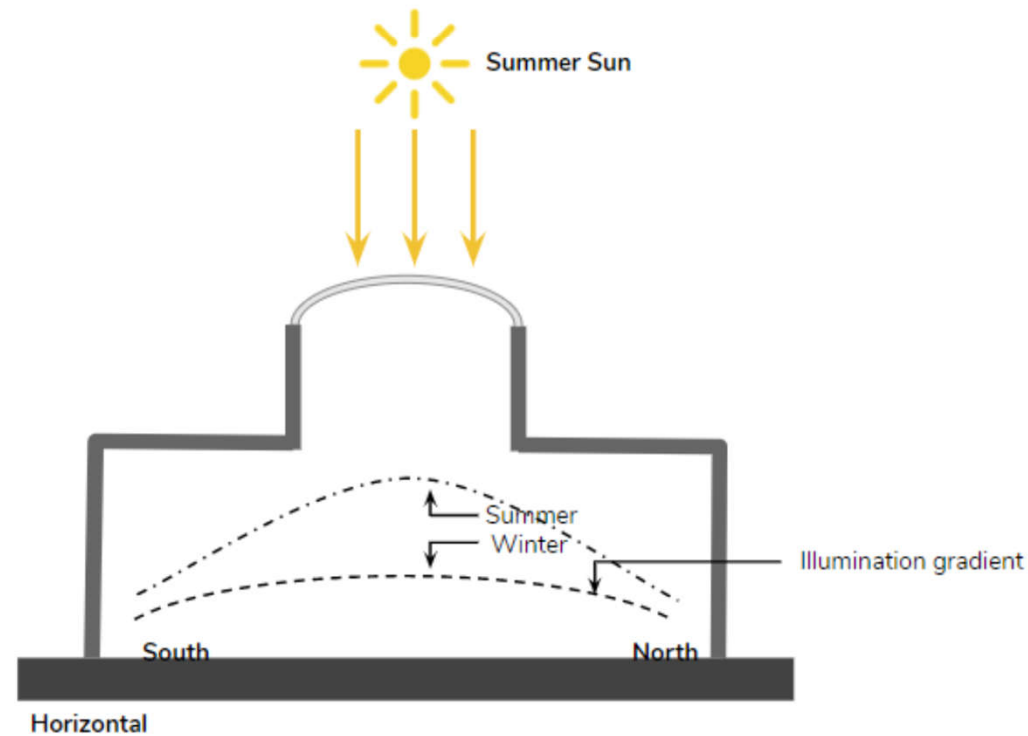
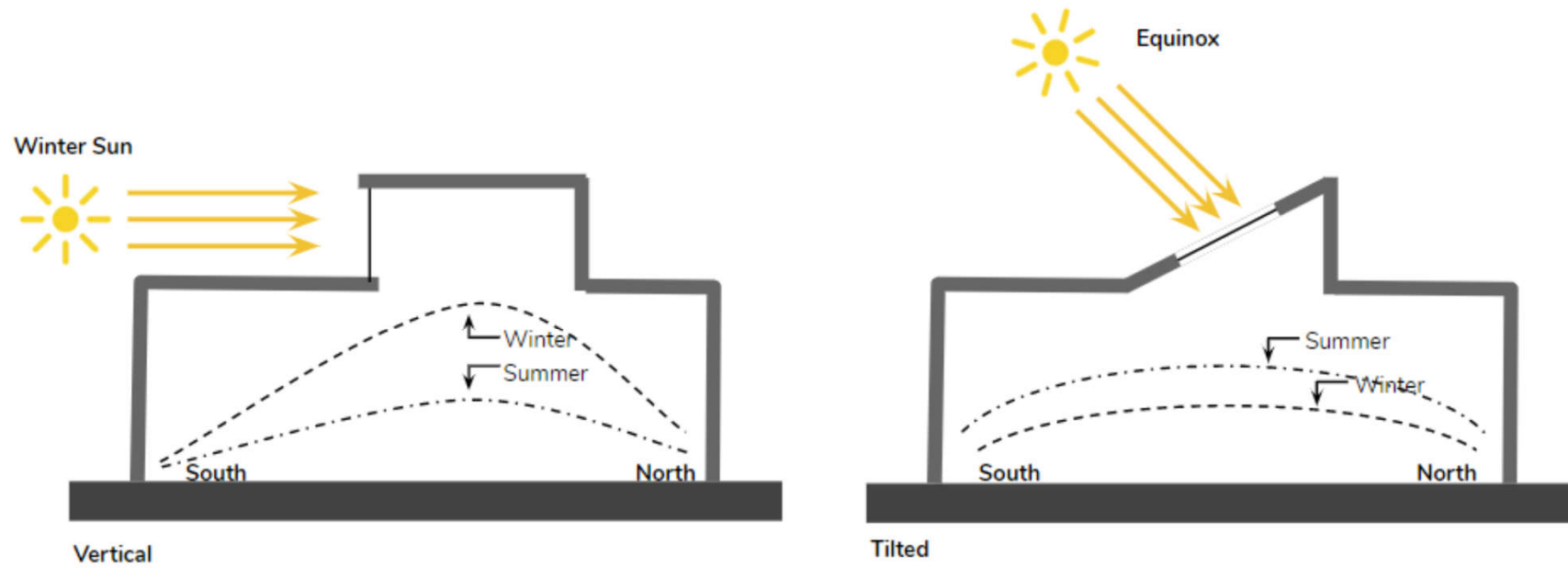

# Daylighting design & control

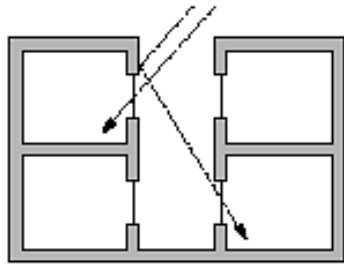

Light well

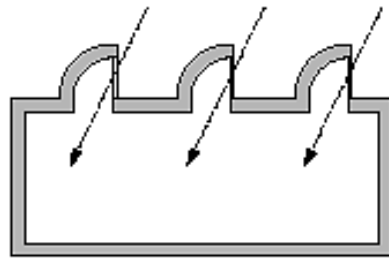

Roof monitor

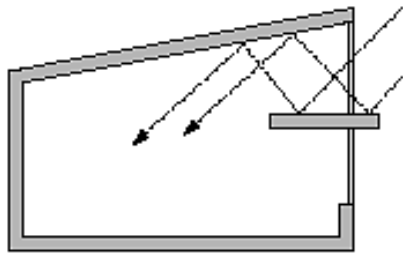

Light shelf

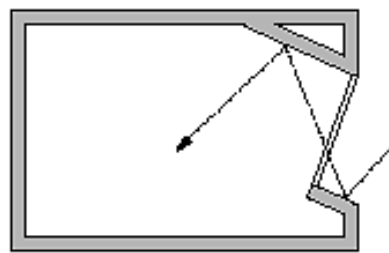

External reflectors

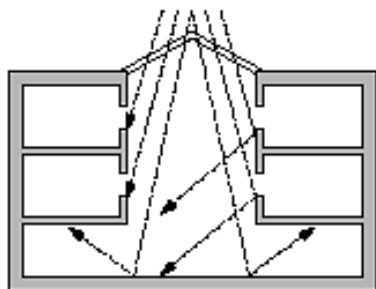

Atrium

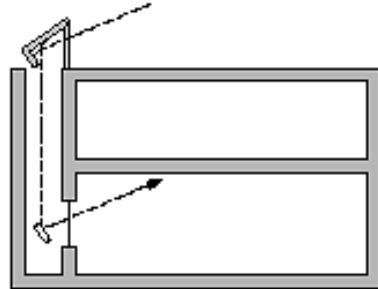

Light duct

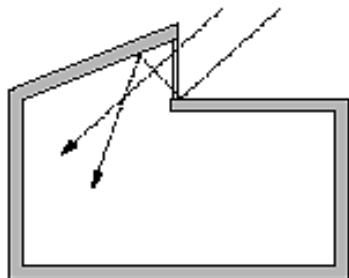

Clerestory

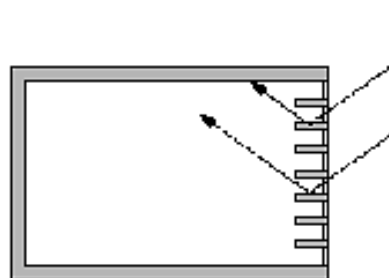

Reflective blinds

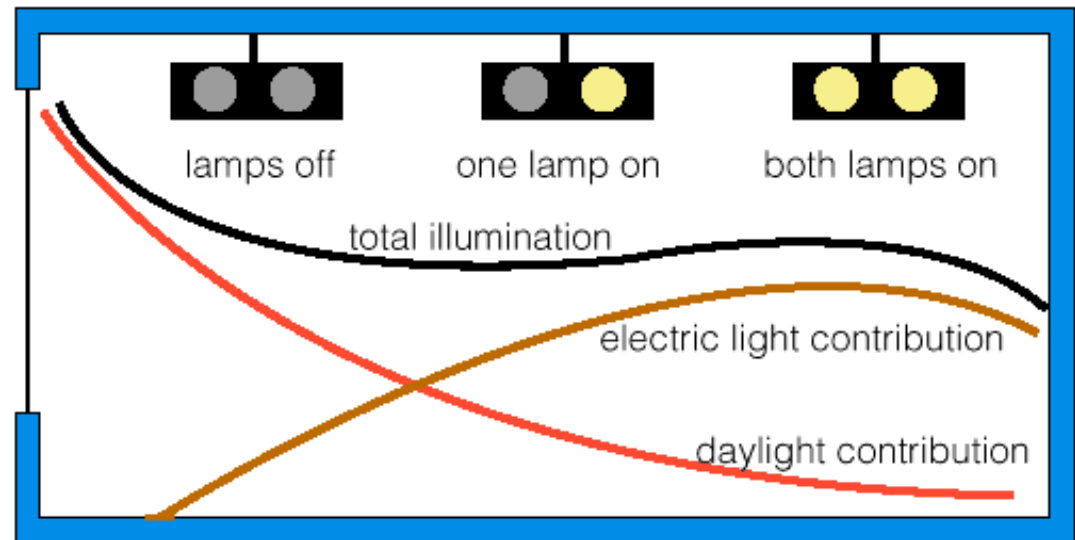



# Suncatchers (vertical light reflector)

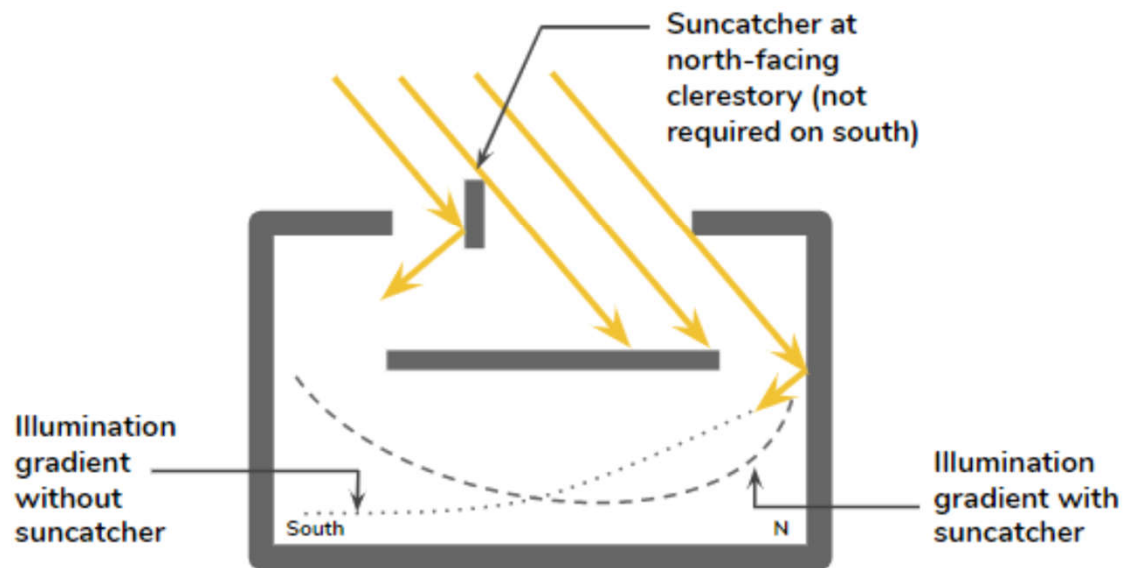
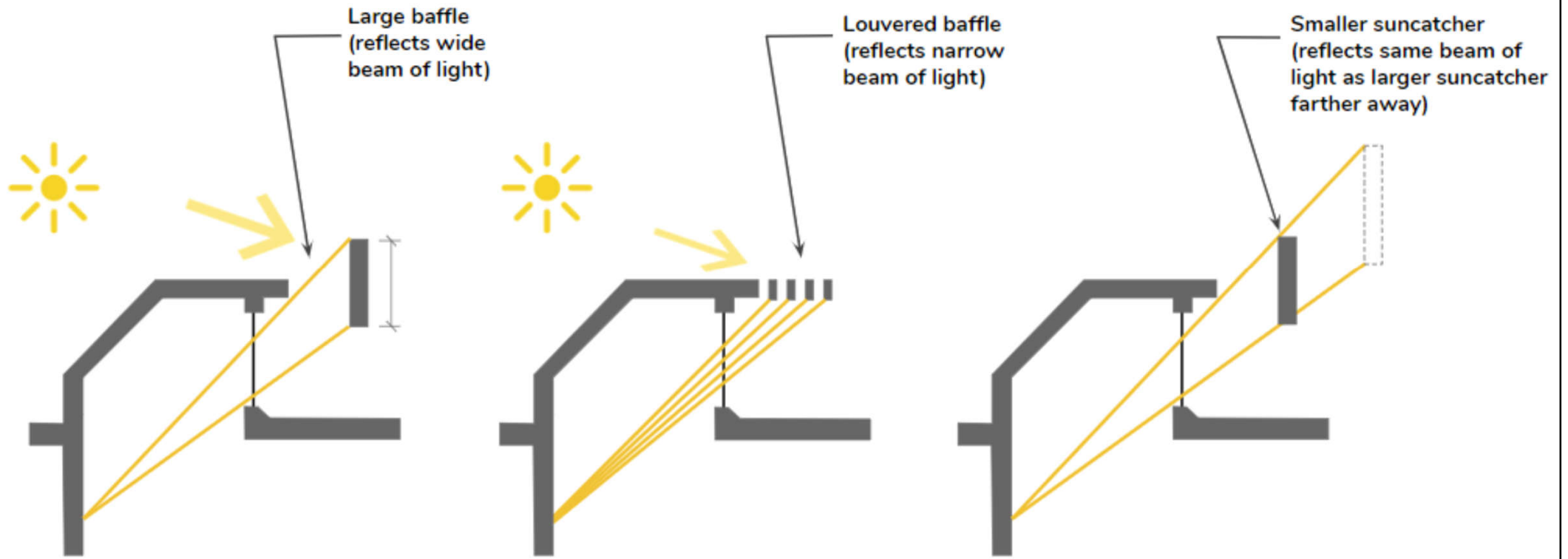

# Atrium daylighting design (Frank Lloyd Wright's Guggenheim Museum & Larkin Building)



(Source: <https://planlux.net/sun-catchers-atria/>)

# Atrium daylighting design with reflecting devices (HSBC Headquarters Building, Hong Kong)

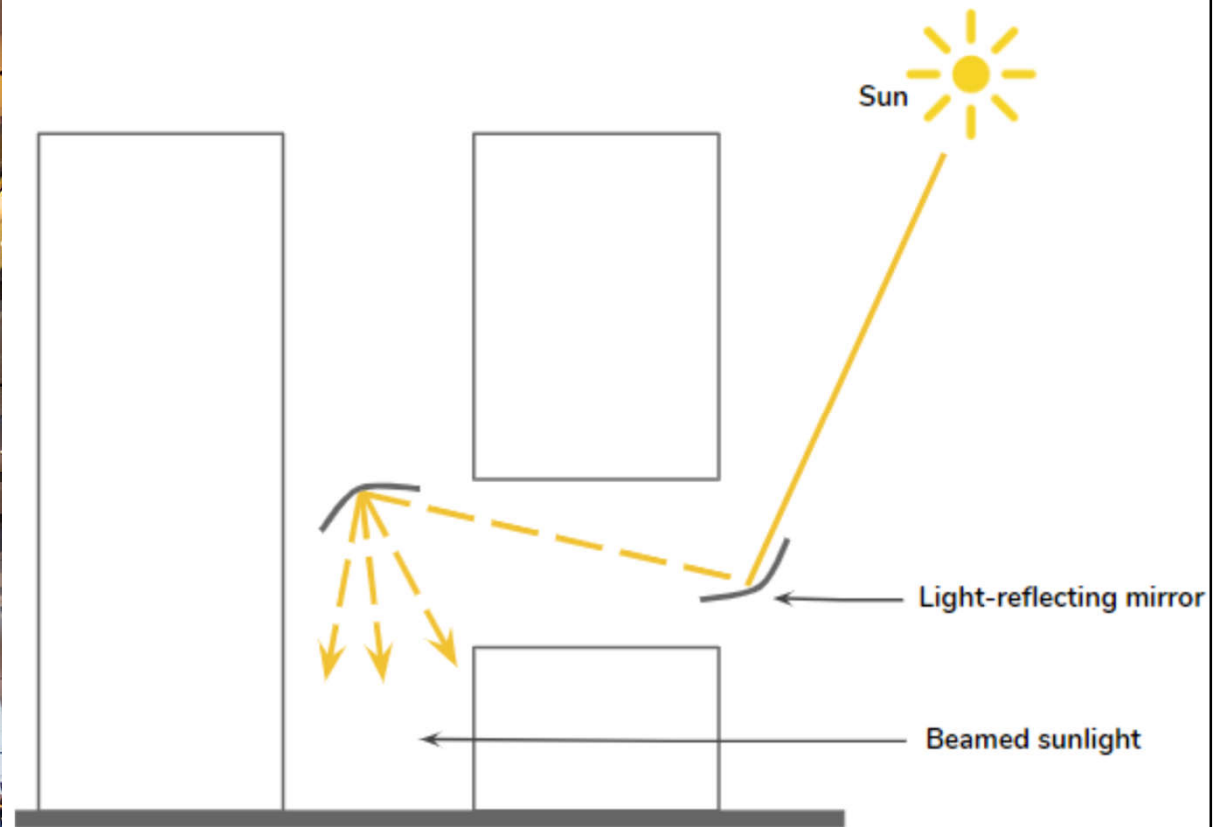
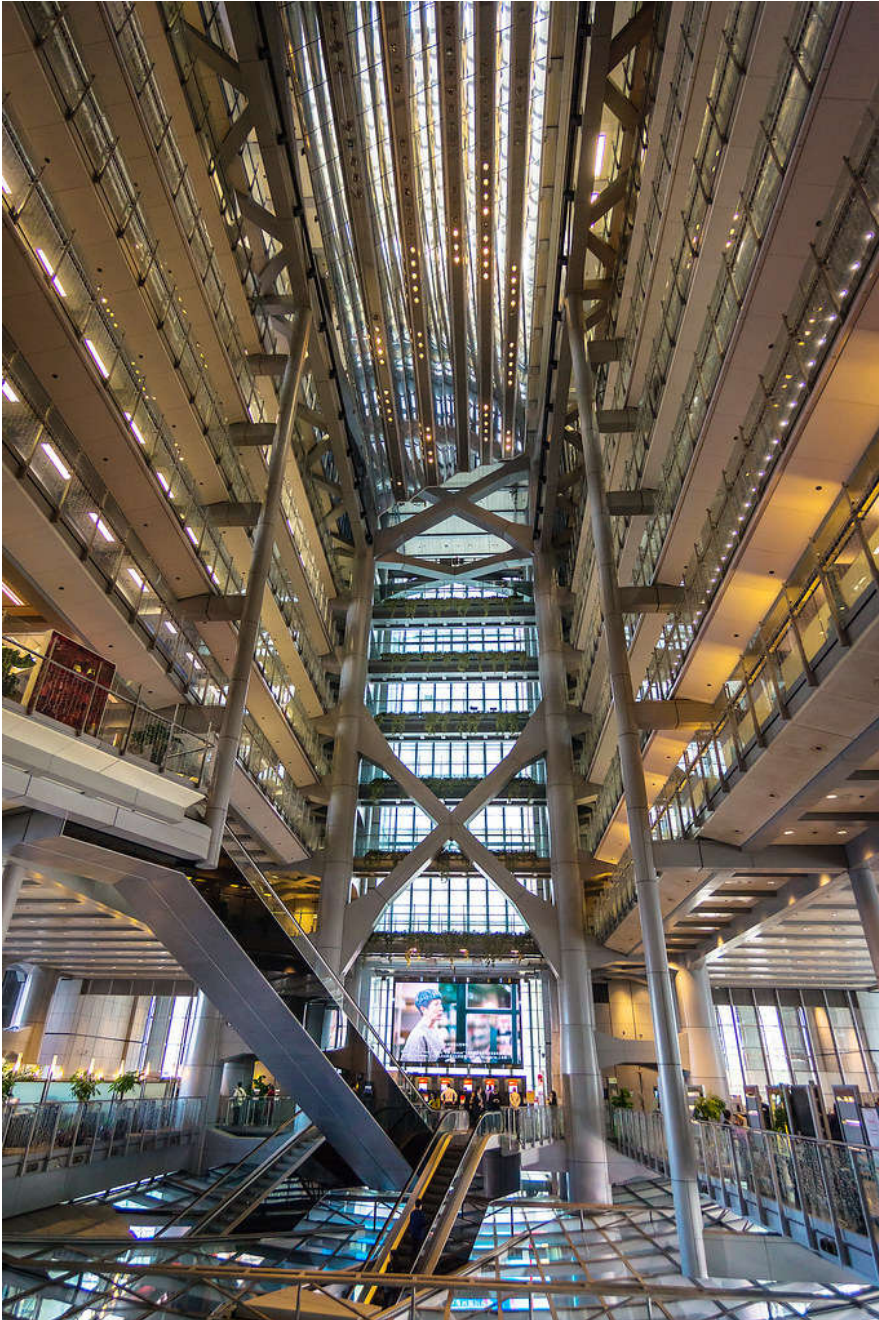

(Source: <https://planlux.net/sun-catchers-atria/>)

# Atrium light enters through vertical clerestory openings

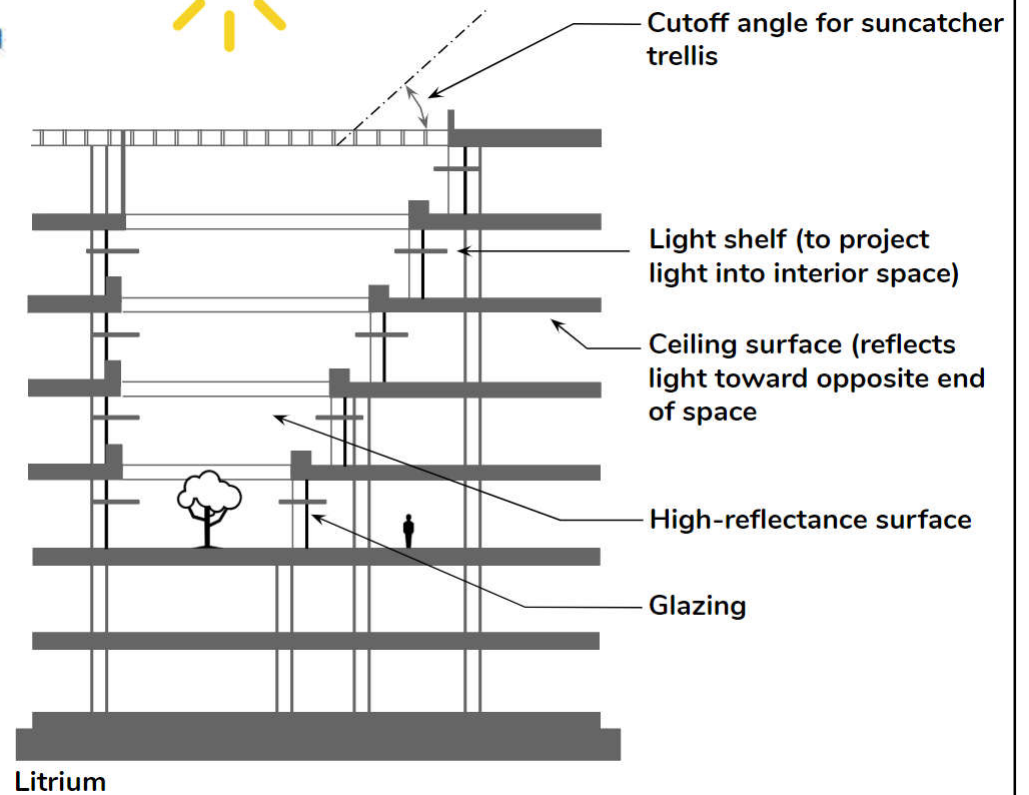
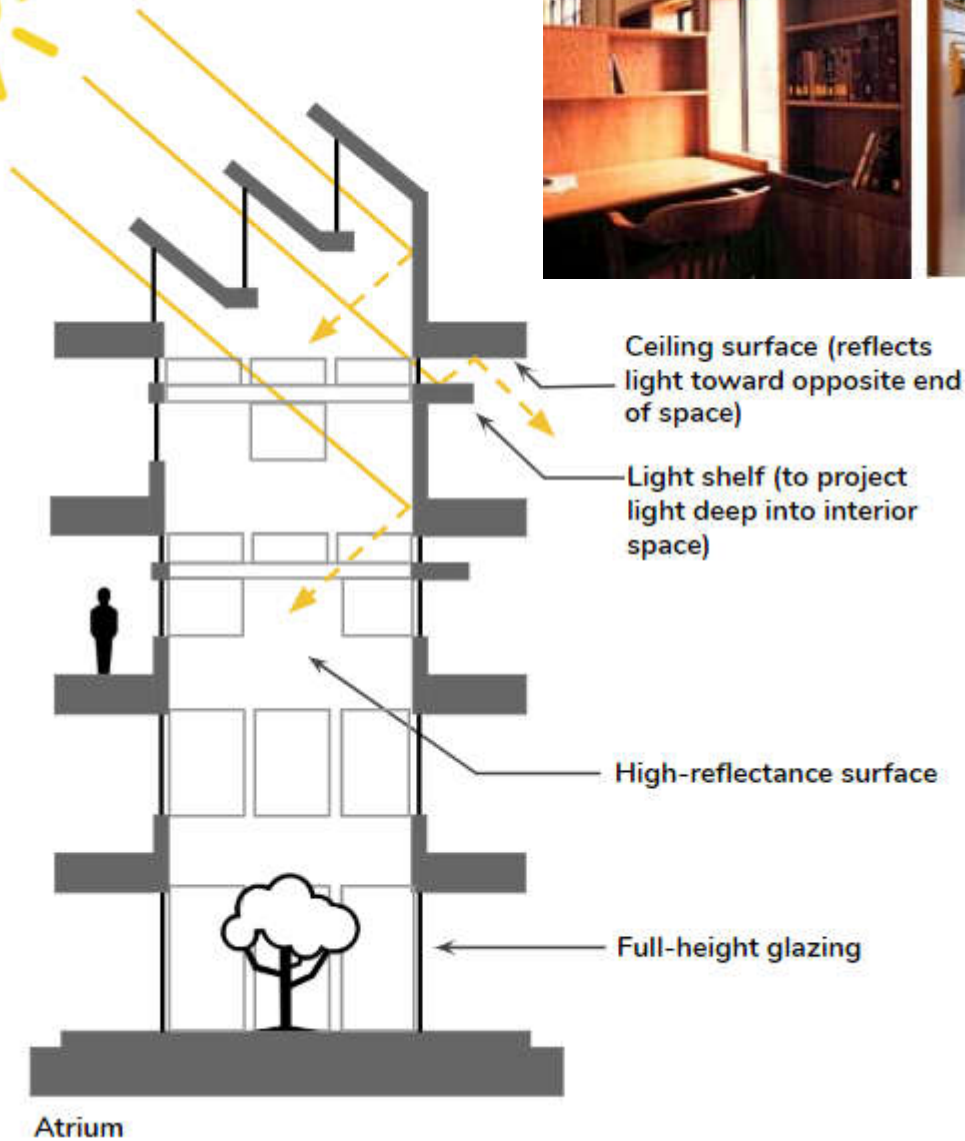

Skylights in O'hare International Airport, Chicago create a bright cheerful combination of natural light, electric light & architectural space

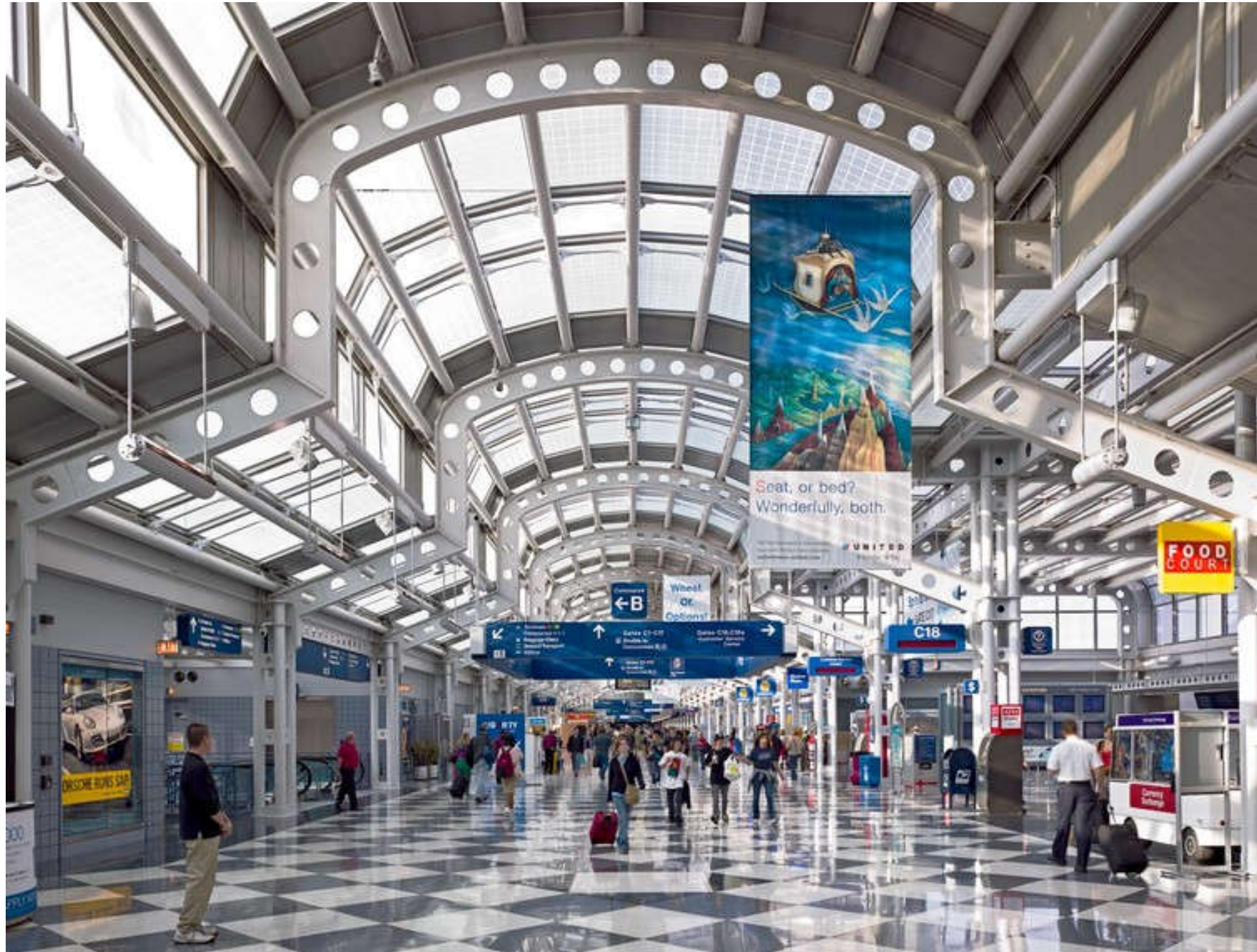

(Source: <https://planlux.net/checklist-for-designing-with-natural-light/>)

# Main window types & daylight distribution systems

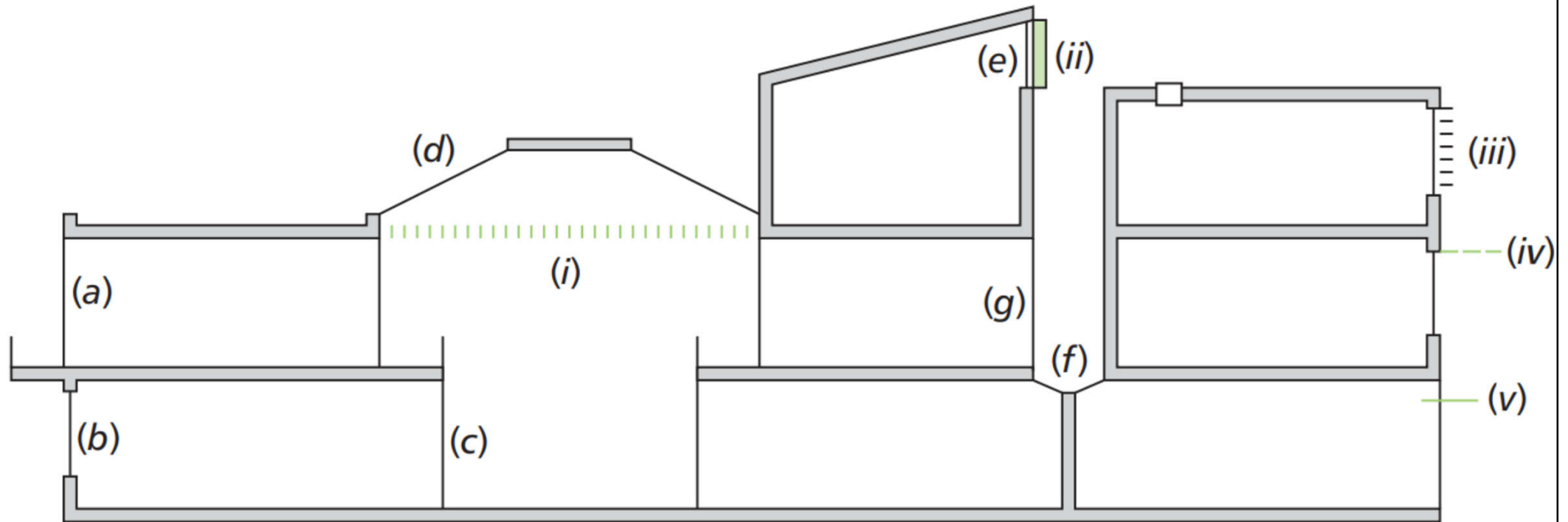

## Window glazing:

- (a) Full height glazing
- (b) Traditional glazing
- (c) Internal glazing ('borrowed light')
- (d) Rooflights
- (e) Clerestory
- (f) Lightwell rooflight
- (g) Lightwell window

## Shading systems:

- (i) Atria shading
- (ii) Vertical shading
- (iii) Vertically stacked shading
- (iv) Horizontally stacked shading
- (v) Lightshelf

The visible sky angle  $\theta$  is measured from the centre of the window, in the vertical plane perpendicular to it

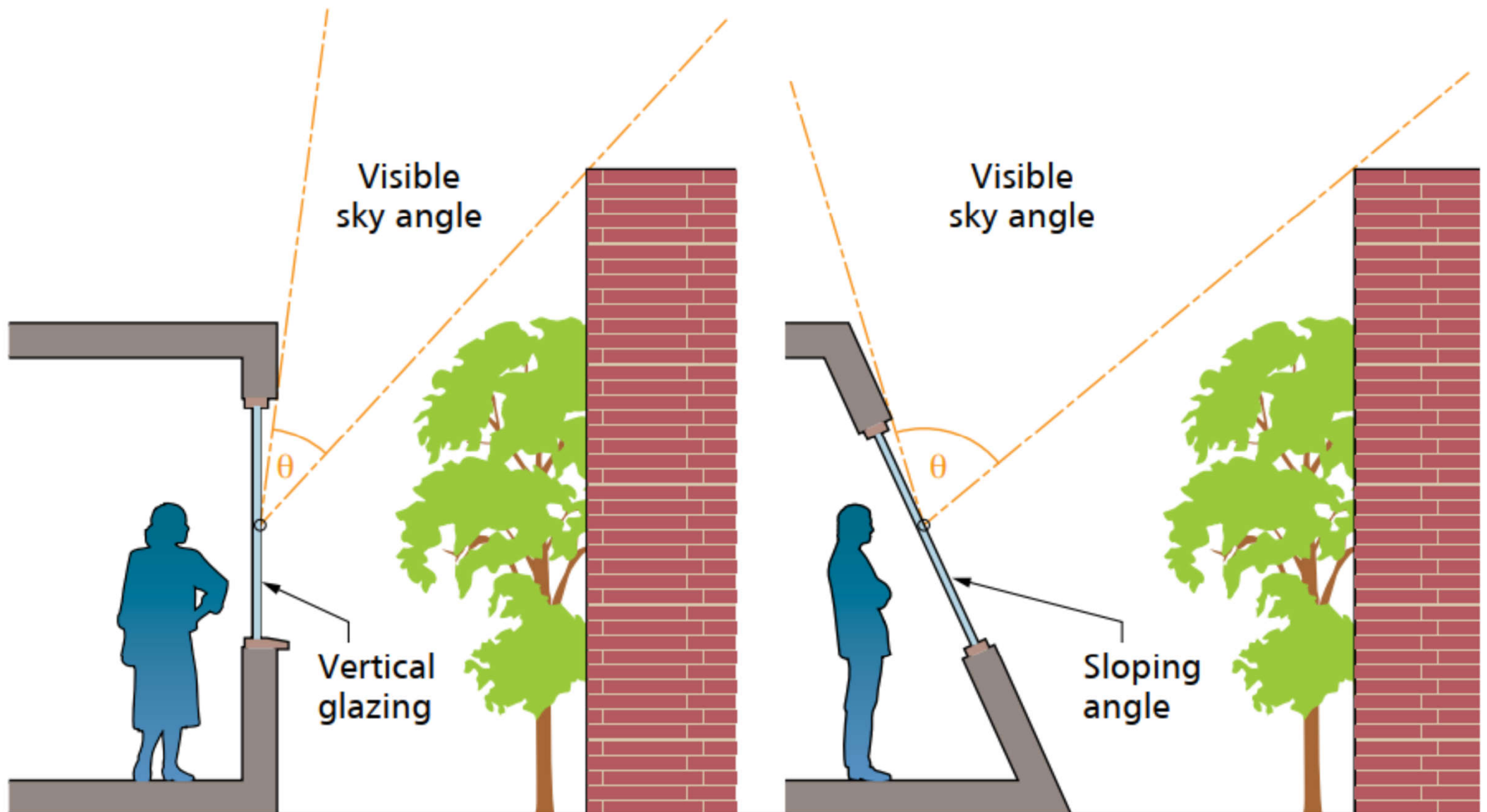

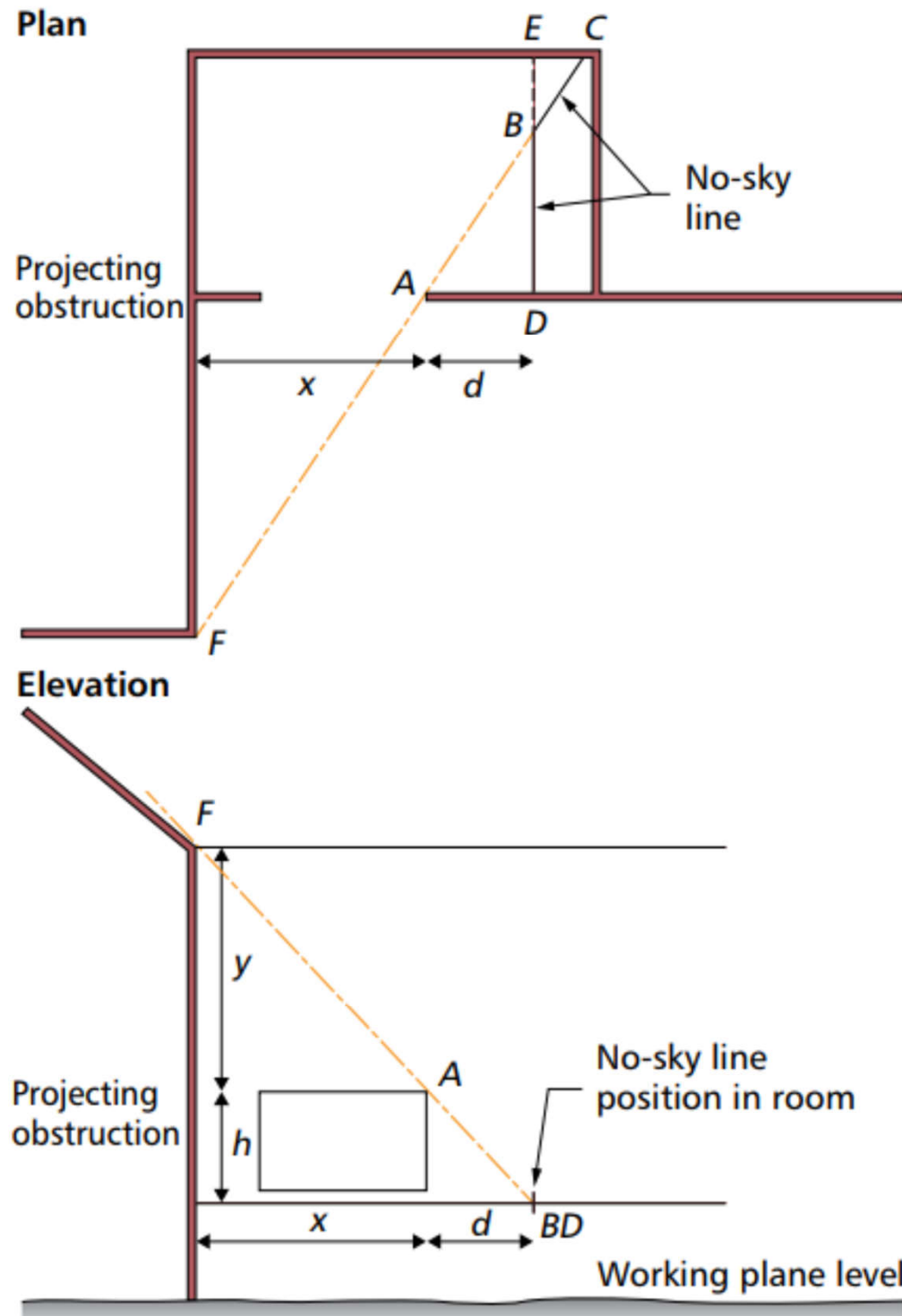
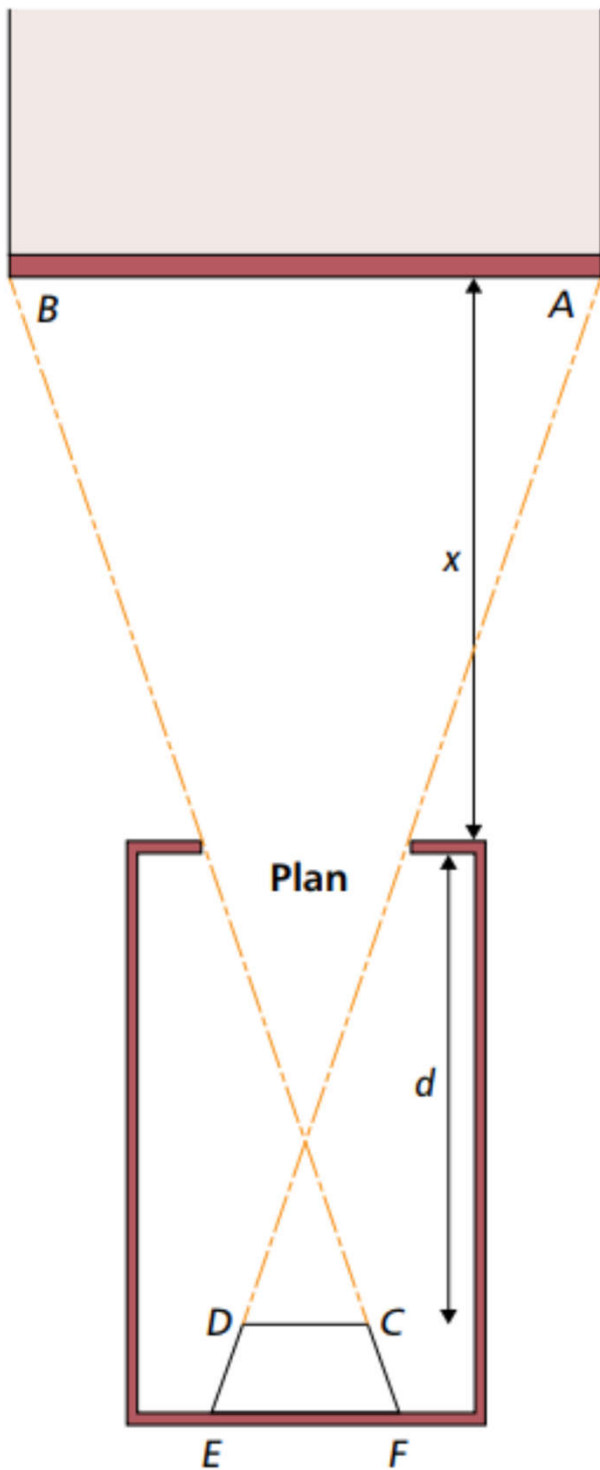

No-sky line & internal space planning



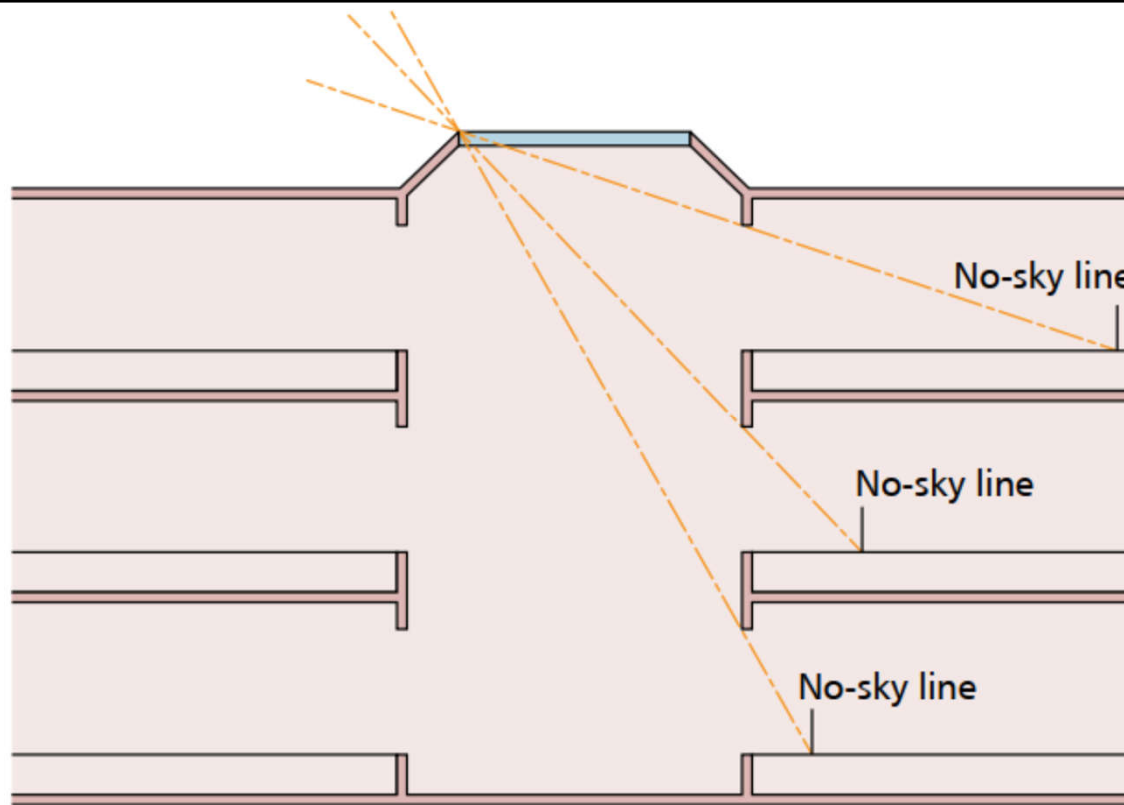

No-sky lines in an atrium building & for an obstructing building

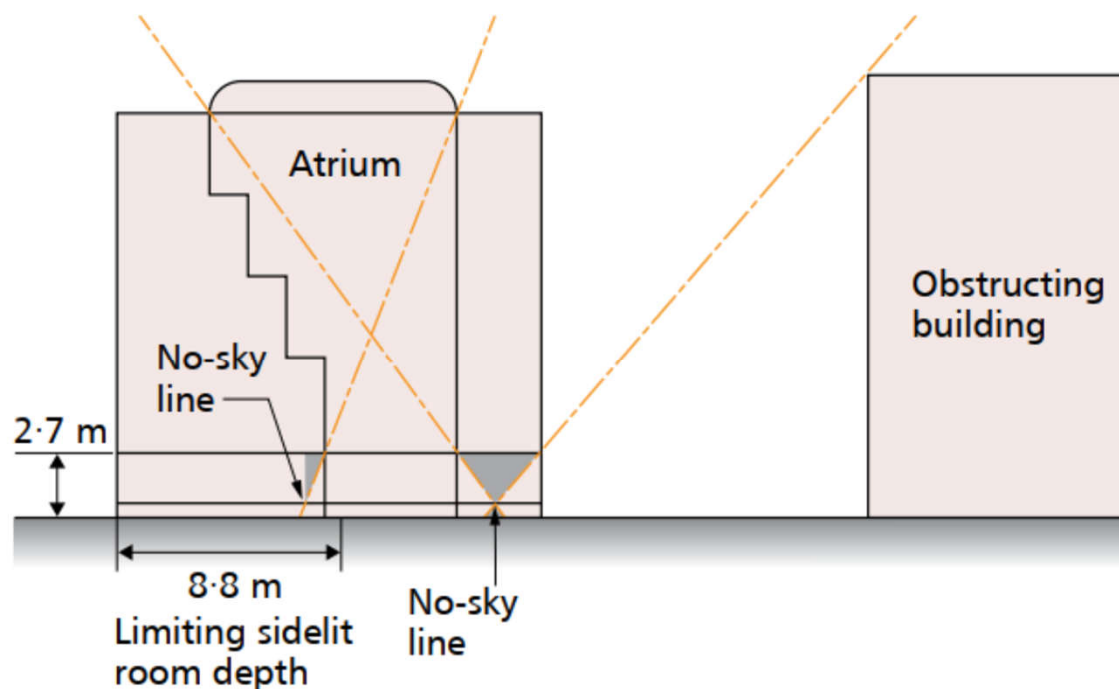

# Sunlight transport in light pipe & solar tube/tunnel

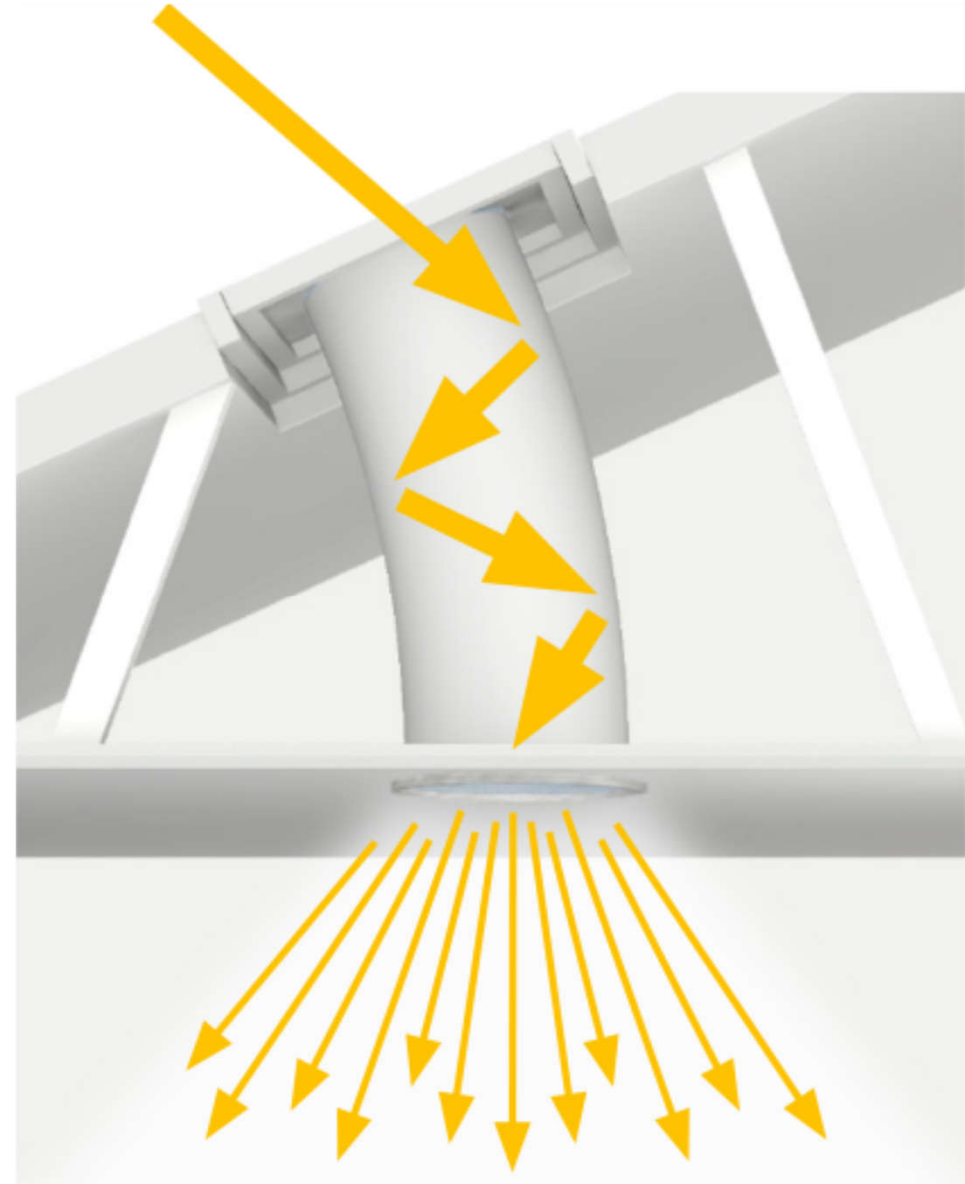
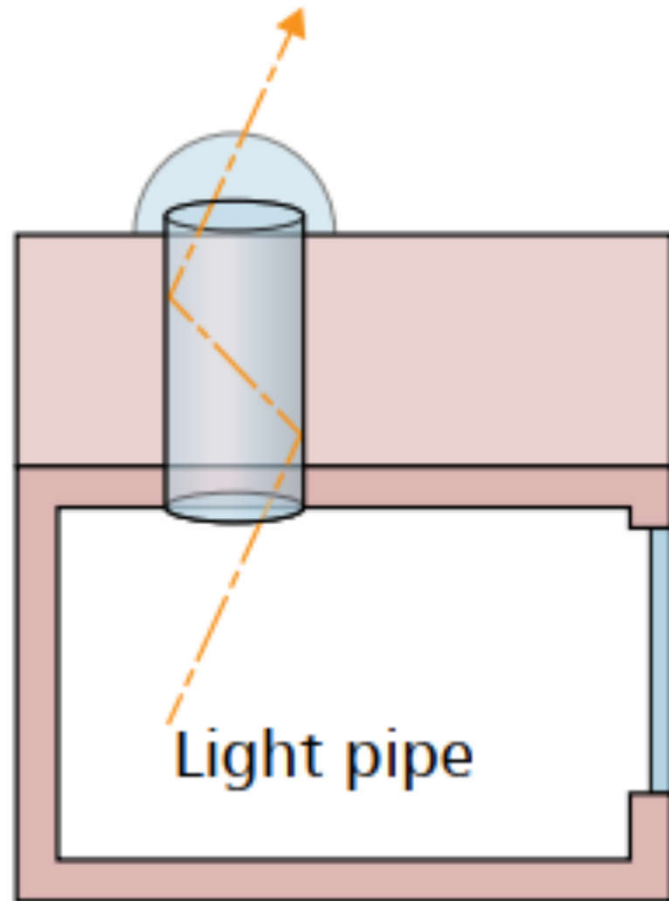

# Sun pipe, solar spot, solar tube & sunflower



SunPipe  
450

Solarspot  
D-38

Solatube  
290DS

Source: [www.solarspot.it](http://www.solarspot.it)



**Sunflower**

Source : [www.wikoda.com](http://www.wikoda.com)



# Shading and controls

- Purpose of daylighting design
  - Indirect & diffuse radiation to provide useful illumination
  - Minimise direct sunlight & glare in the spaces
  - Controlling electric lighting in accordance with daylight
  - Reduce contrast in daylight between perimeter & interior areas
- Shading devices & window glazing

# Examples of window shading methods

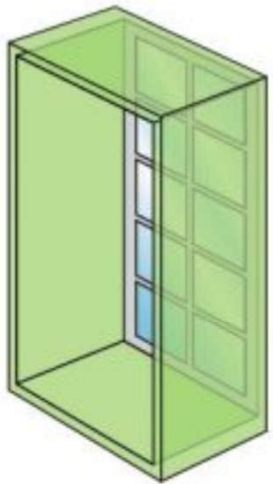

Recessed window

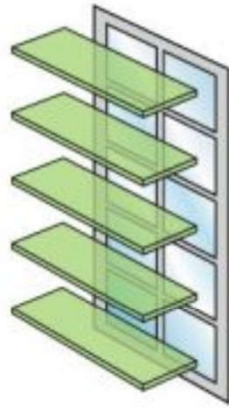

Horizontal fixed shade

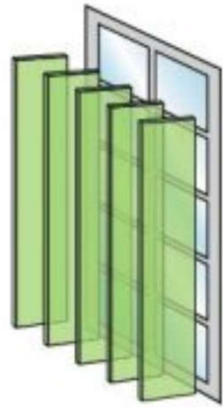

Vertical movable shade

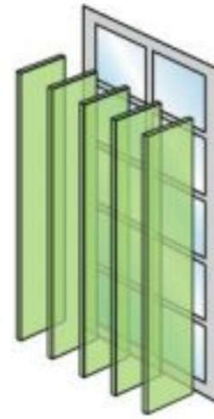

Vertical fixed shade

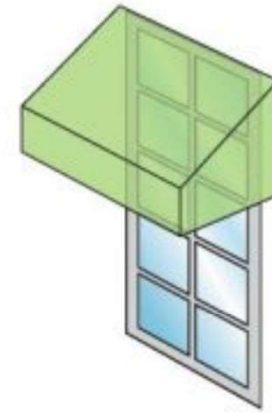

Awning

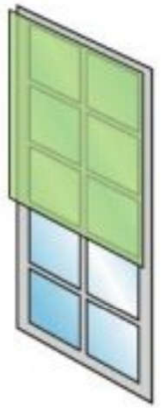

Exterior operable shade

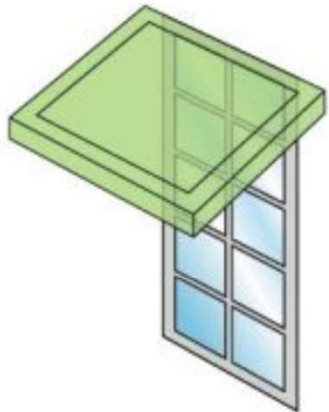

Bahama shutter

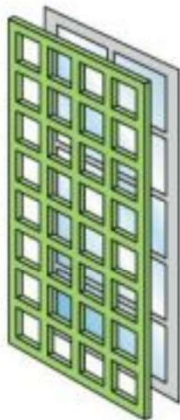

Trellis

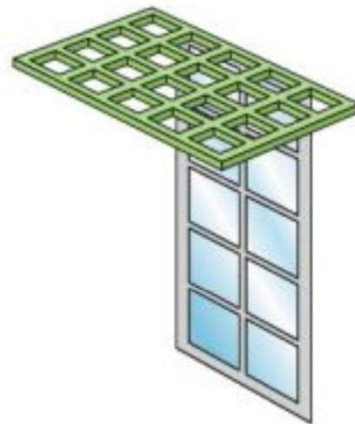

Perforated horizontal overhang

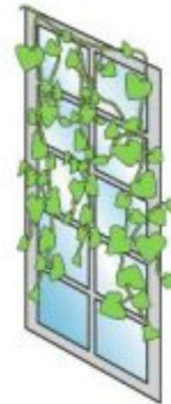

Vegetation on window

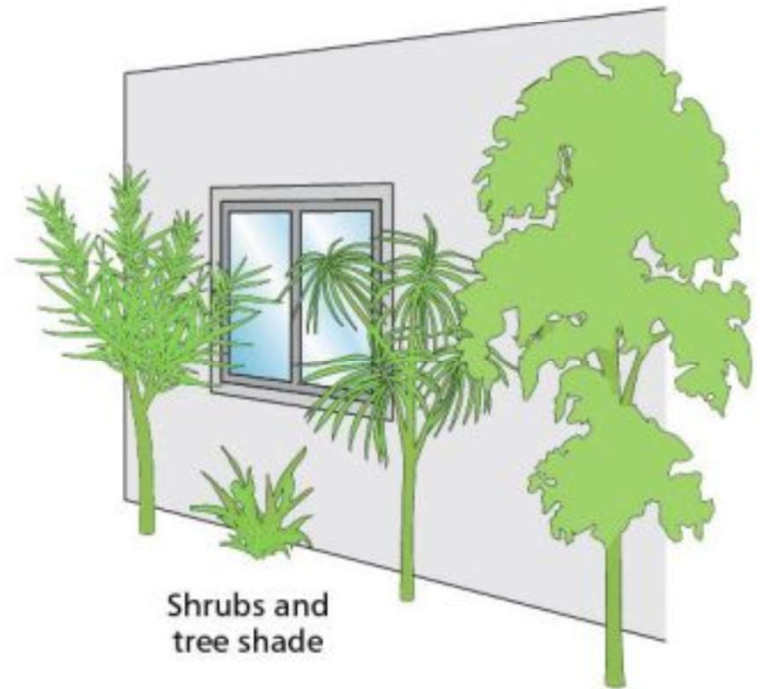

Shrubs and tree shade

# Different types of external & internal shading devices

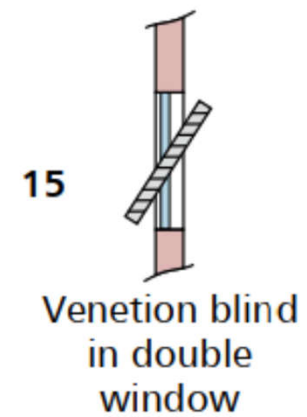
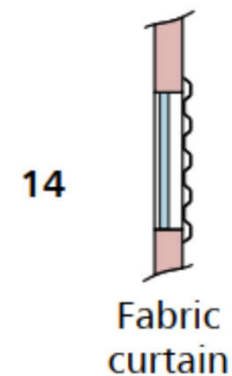
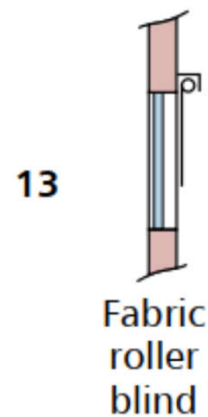
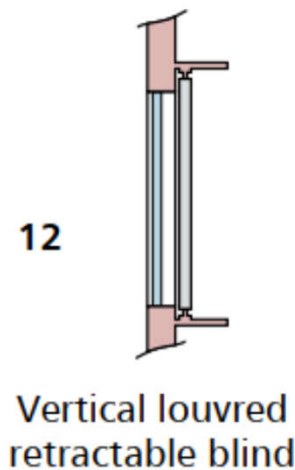
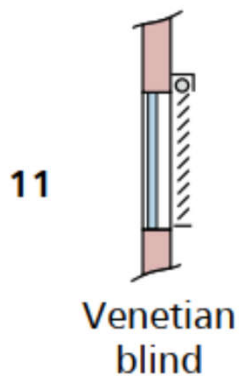
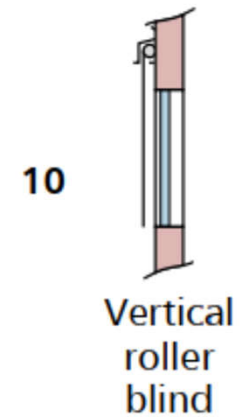
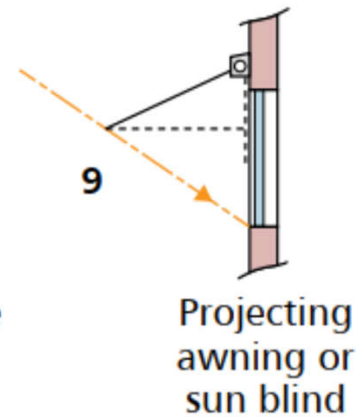
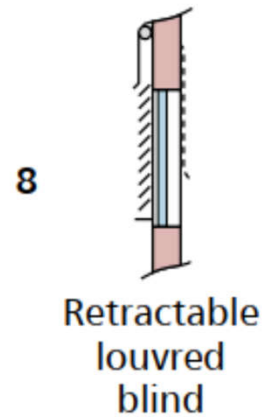
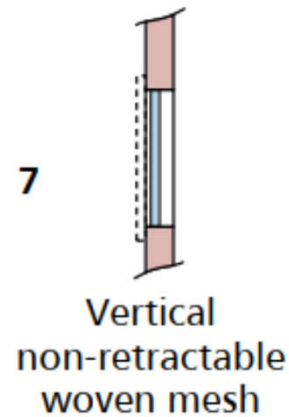
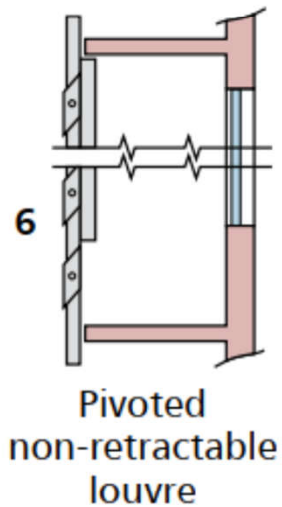
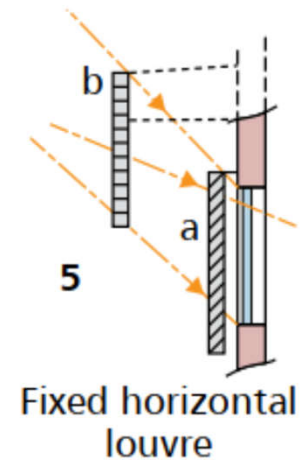
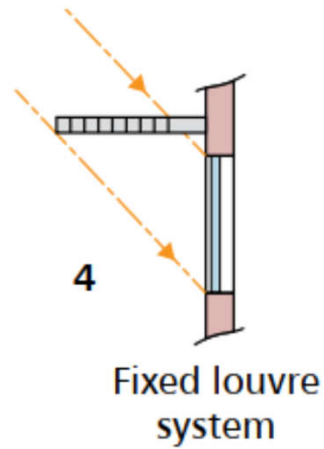
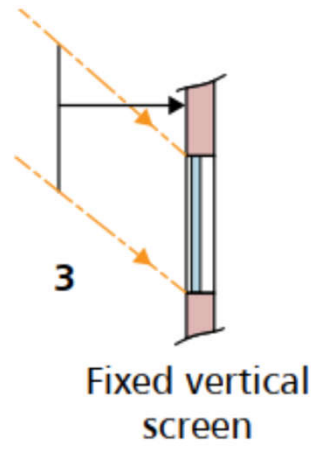
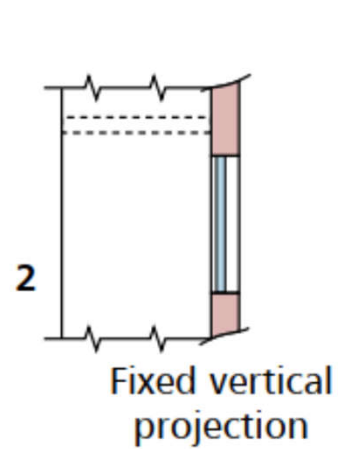
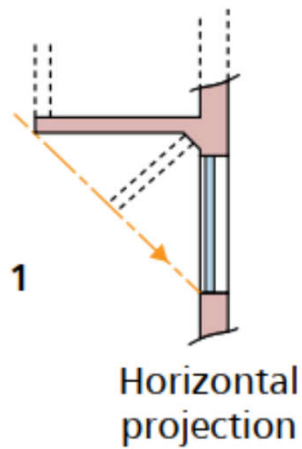

# Spectral transmittance of different glass types

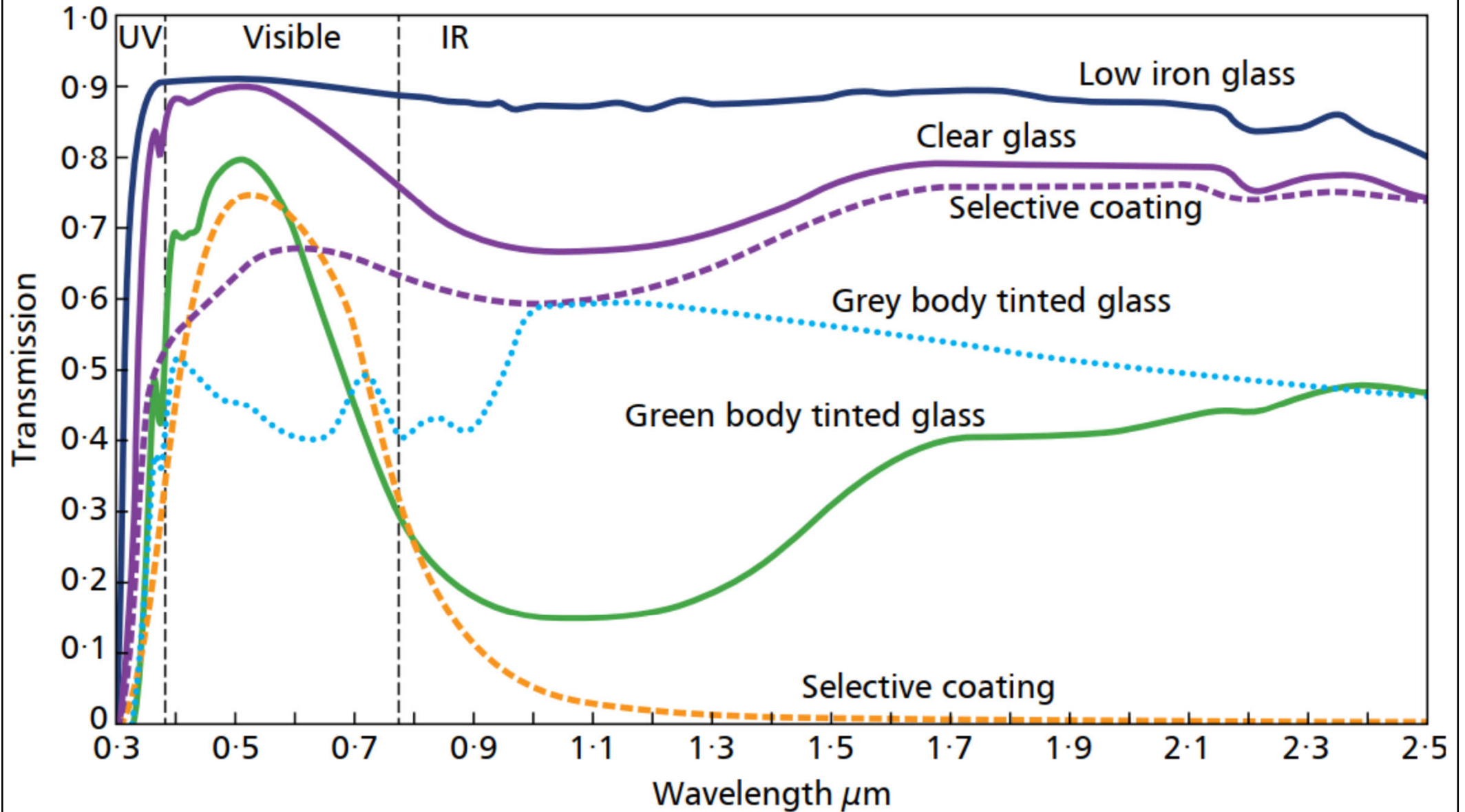

# Shading and controls



- Glare/Thermal control strategies:
  - Automated exterior shading
  - Fixed exterior architectural shading
  - Exterior fabric awnings
  - High performance glazing
  - Operable windows
  - Automated interior shading / double skin systems
  - Manual interior shading



# Different shading solutions & their effects



Interior shading, Venetian blind



Exterior shading, roller shutter



Interior shading, pleated Blind



Exterior shading, awning blind

# Horizontal & vertical shading devices

## Section views

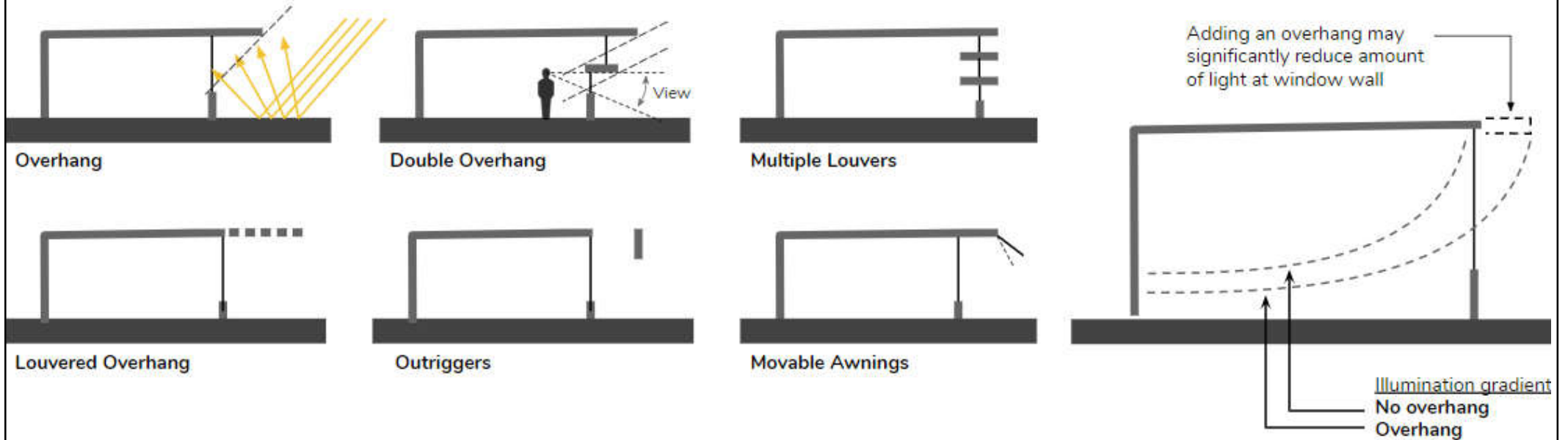

## Plan views

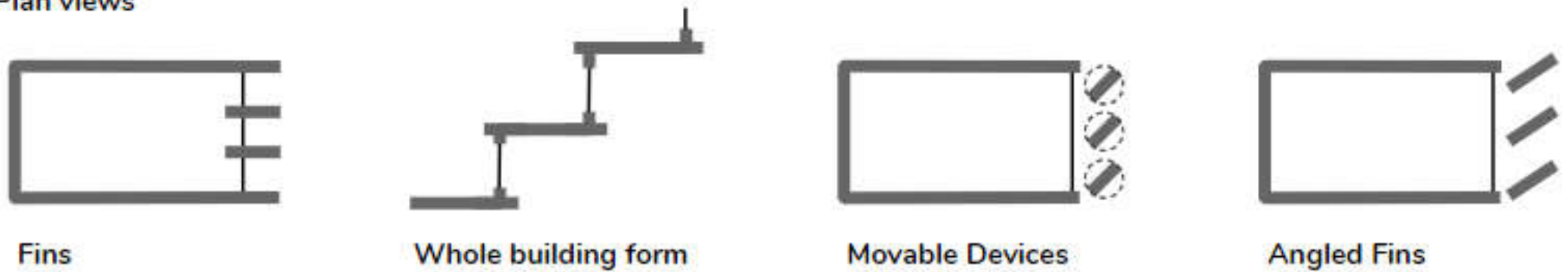

# Light shelves for horizontal shading & redirecting

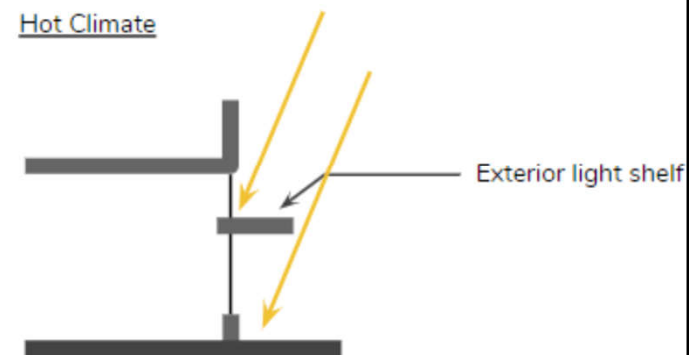
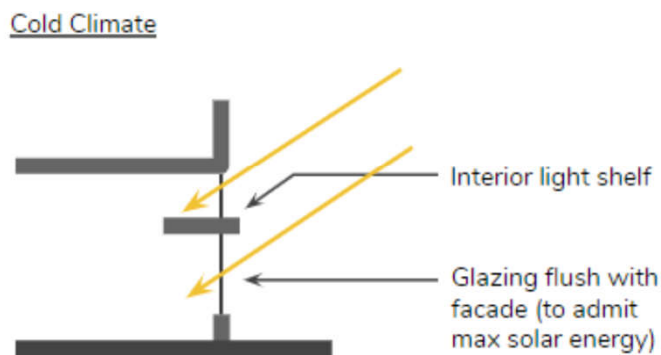
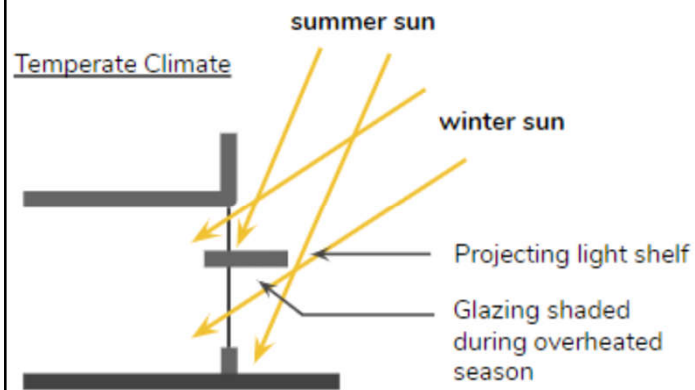
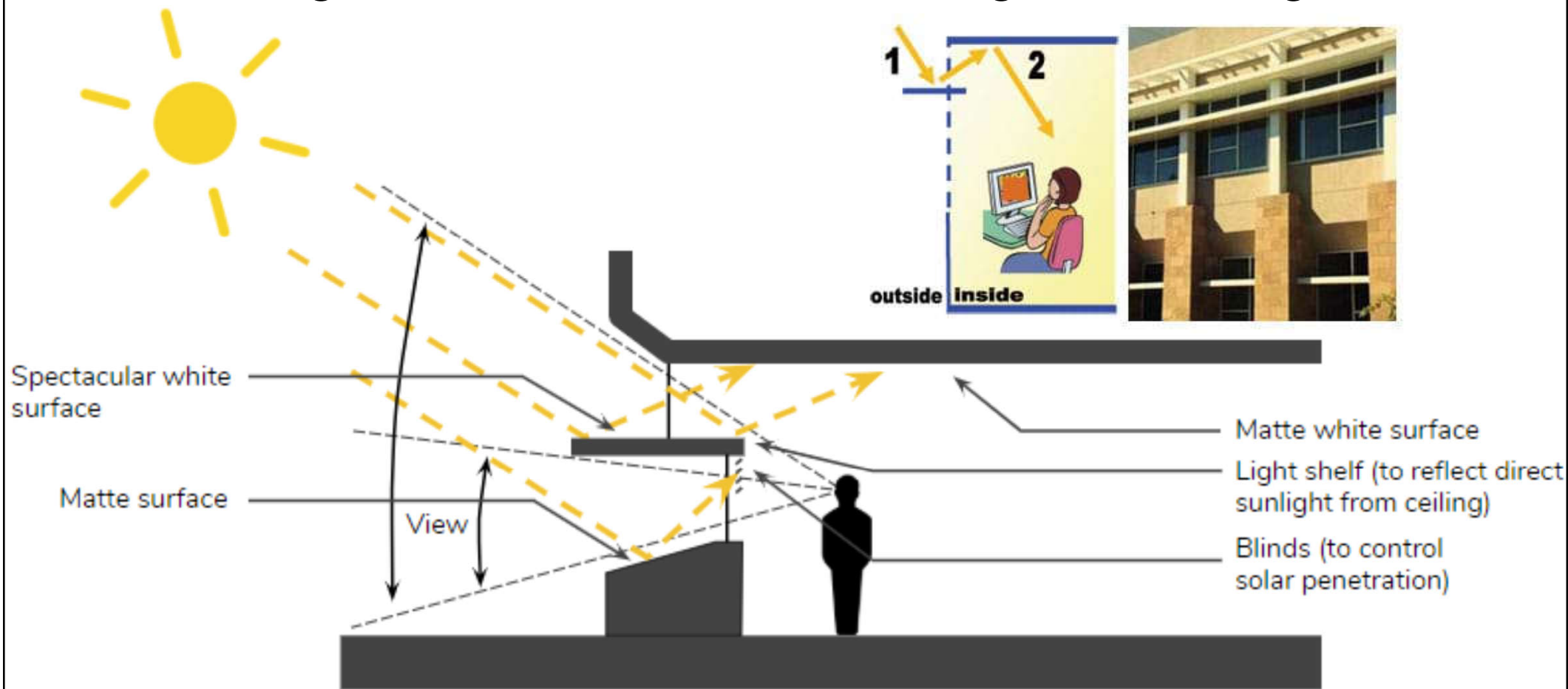

# Projecting light shelves provide additional shading for the lower window; sloping the shelves to distribute light

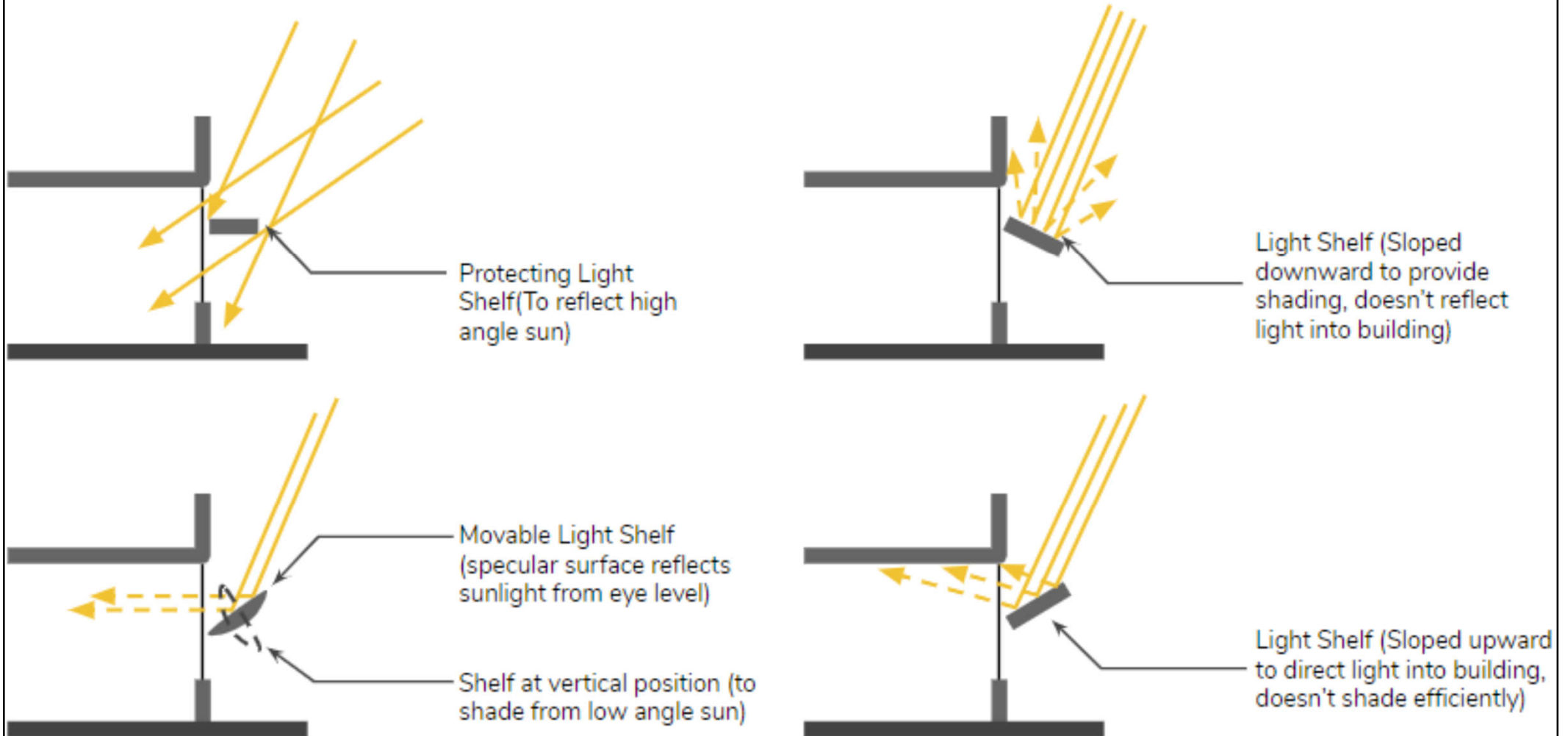

# Level light shelf with an inward sloping wedge pushing high angle sunlight more deeply into space

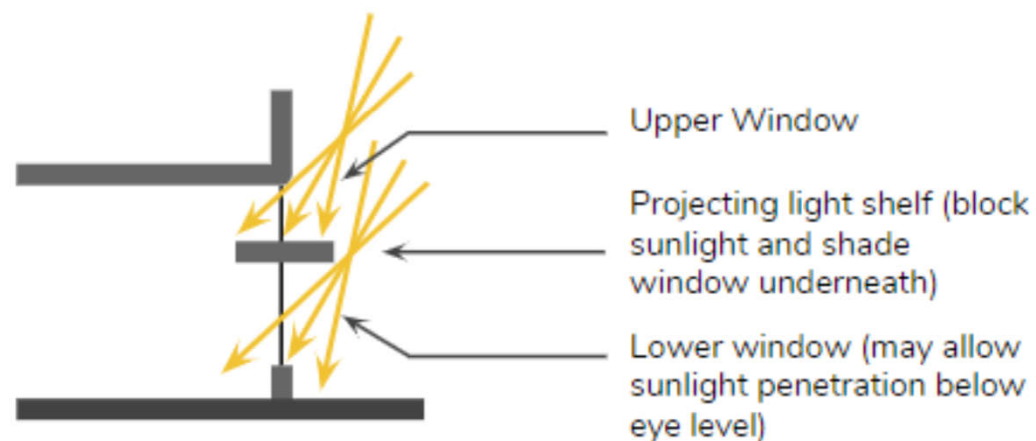
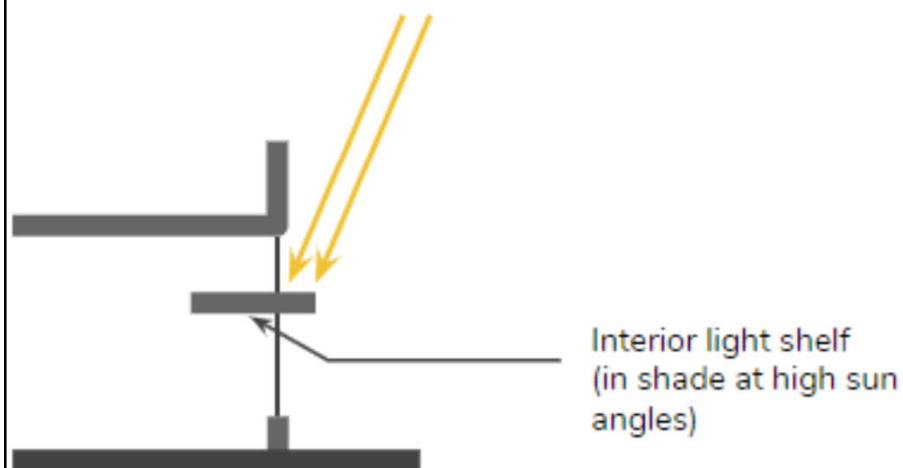
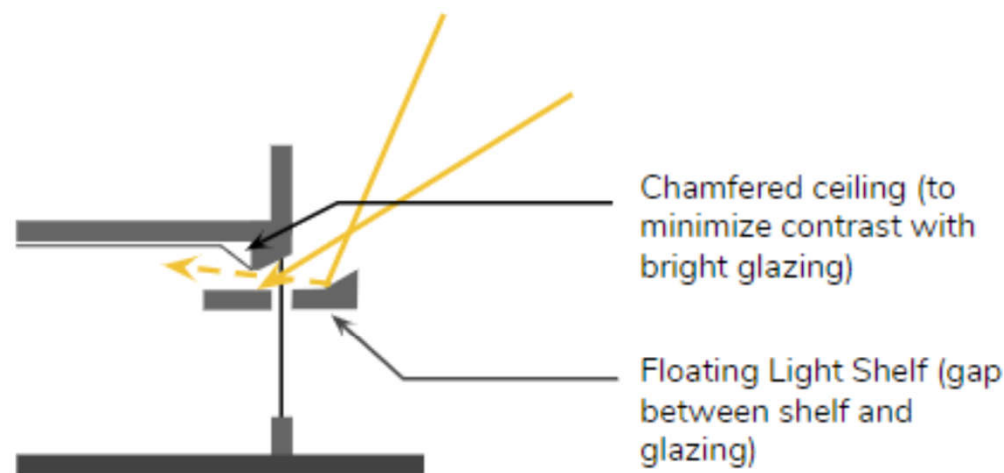
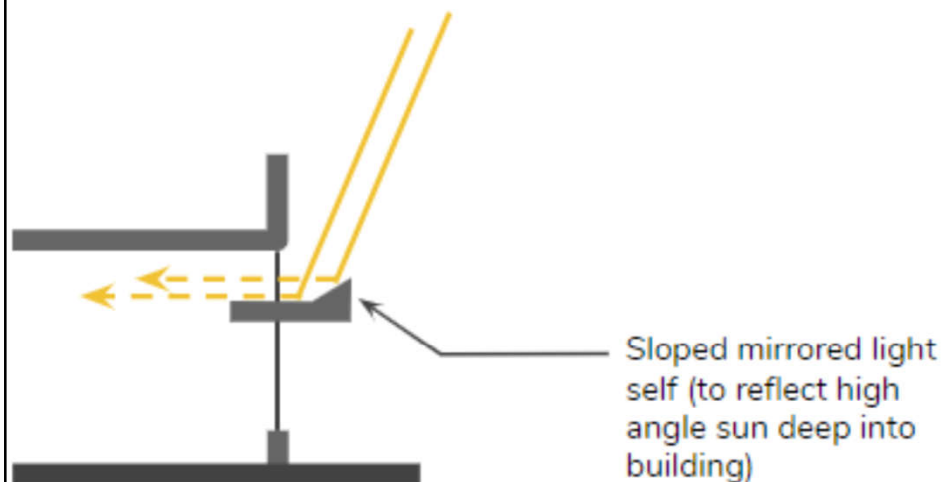

# Sunlighting strategies (should be integrated with architecture to use the sunlight indirectly)

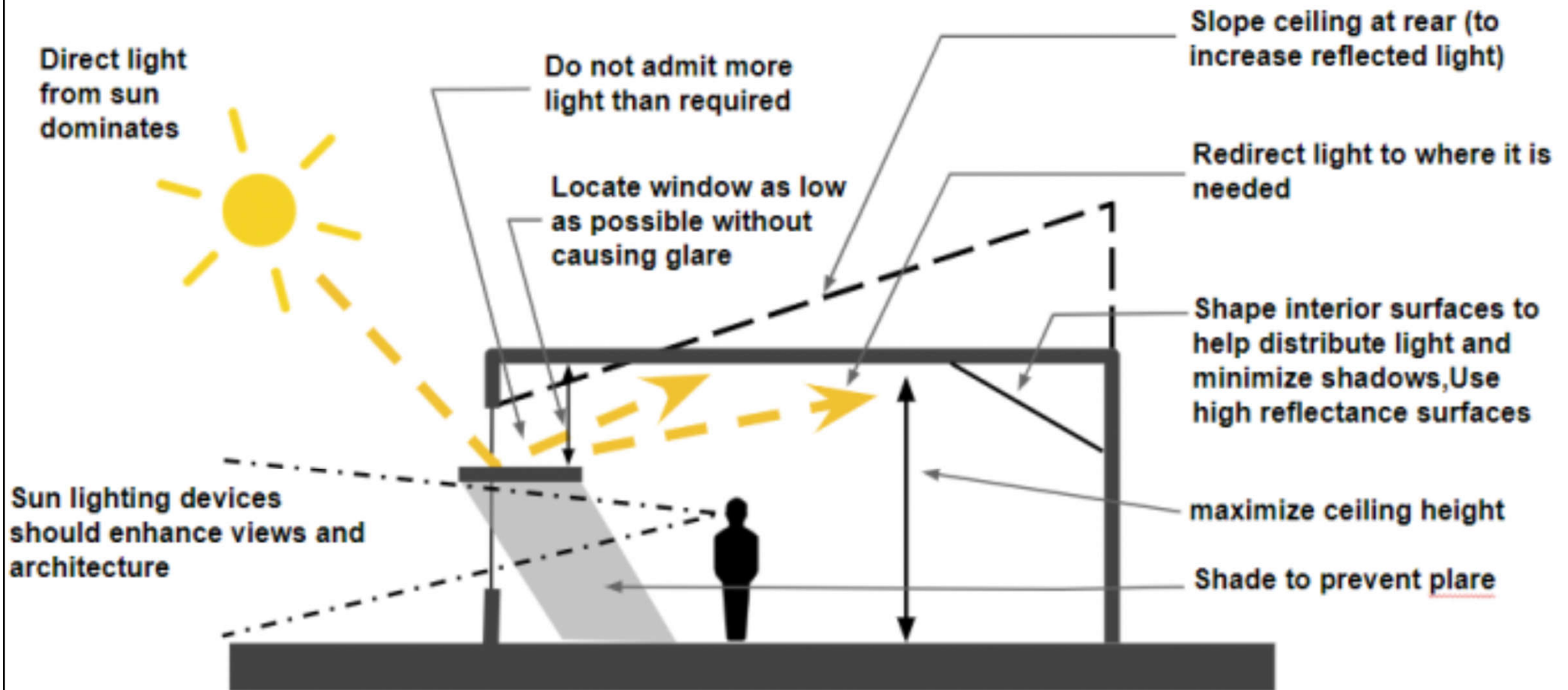

# Sidelit building with sloped ceiling at perimeter

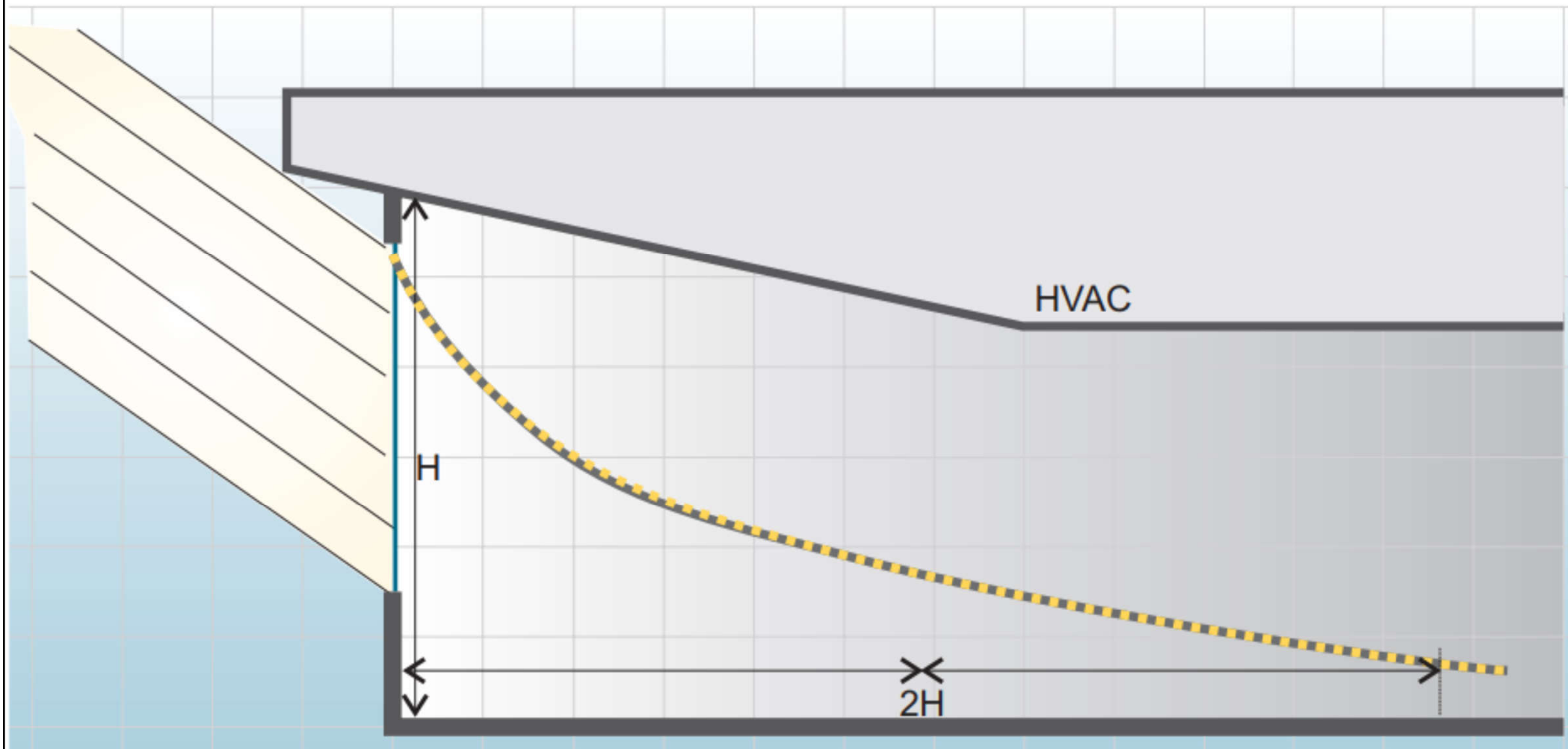

# Lighting level contours for punched windows & continuous strip windows

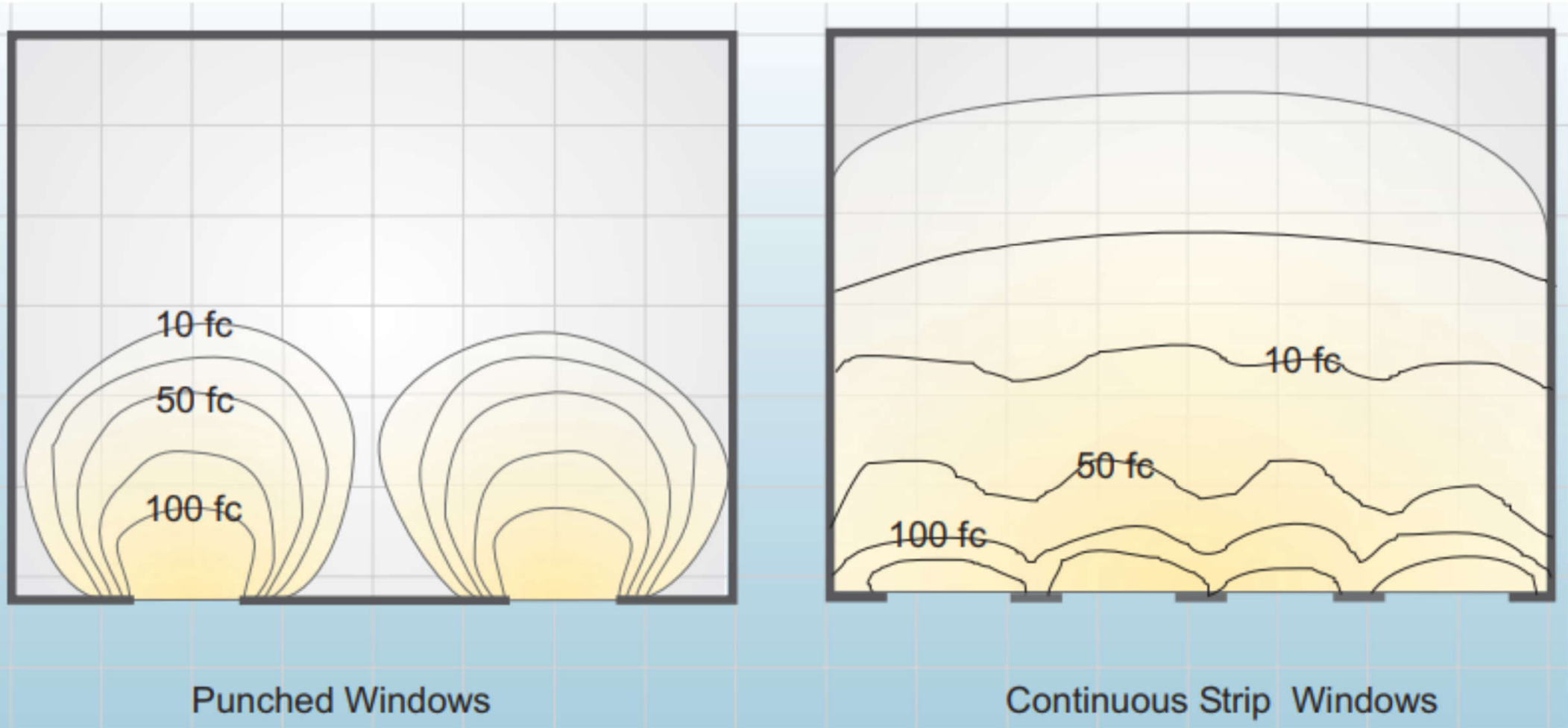



# Cut-off angles for light shelf & louvre system

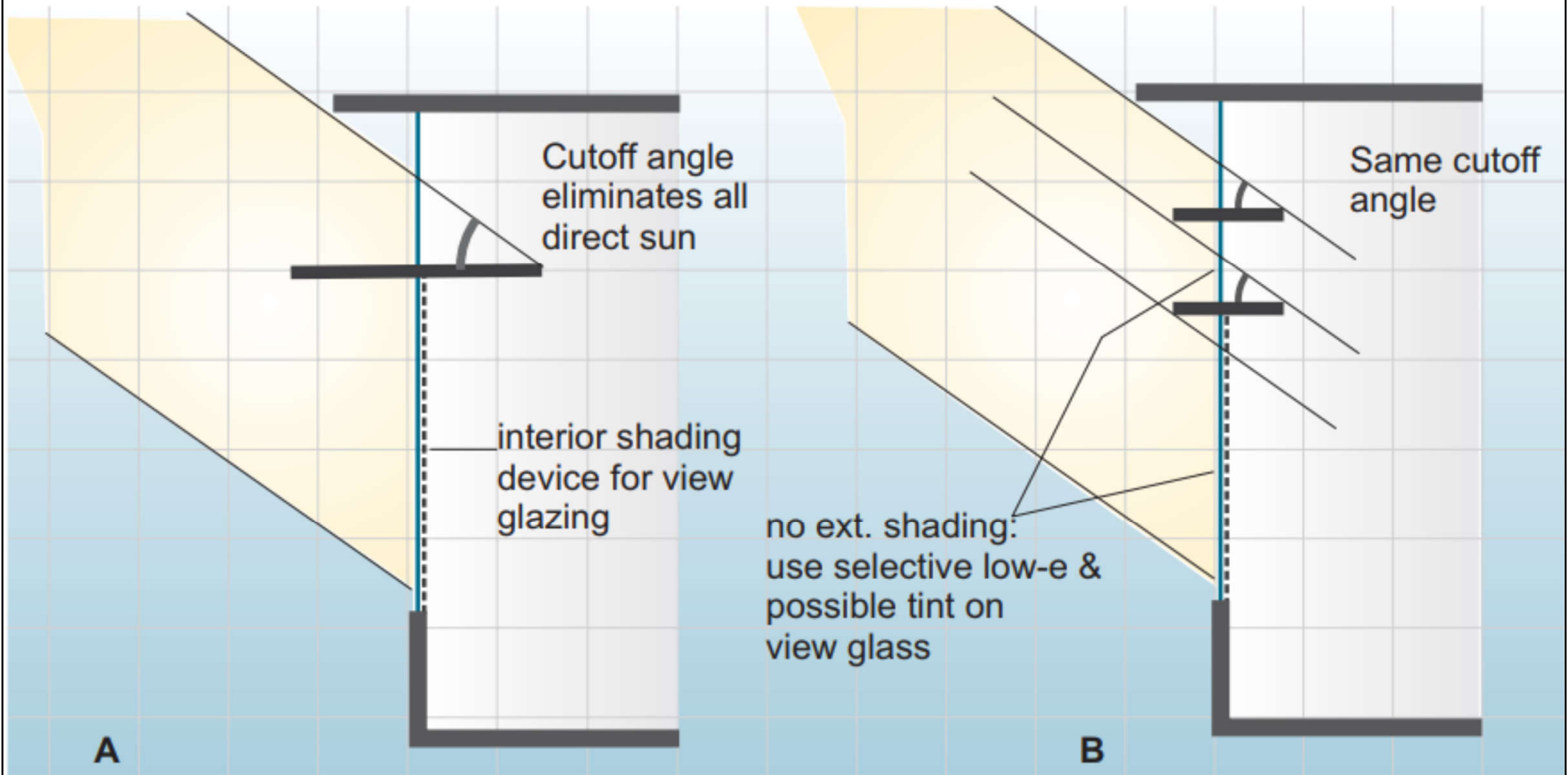



# Shading and controls

- Understand daylight distribution & lighting needs for the space
  - Daylighting controls on ambient/general lighting
  - Accent lighting on a time schedule
  - Task lighting may be manually controlled or occupancy sensed
- Electric lighting should be designed from the start with daylighting in mind
  - Align the circuits with daylight patterns

# Daylight isolux contours

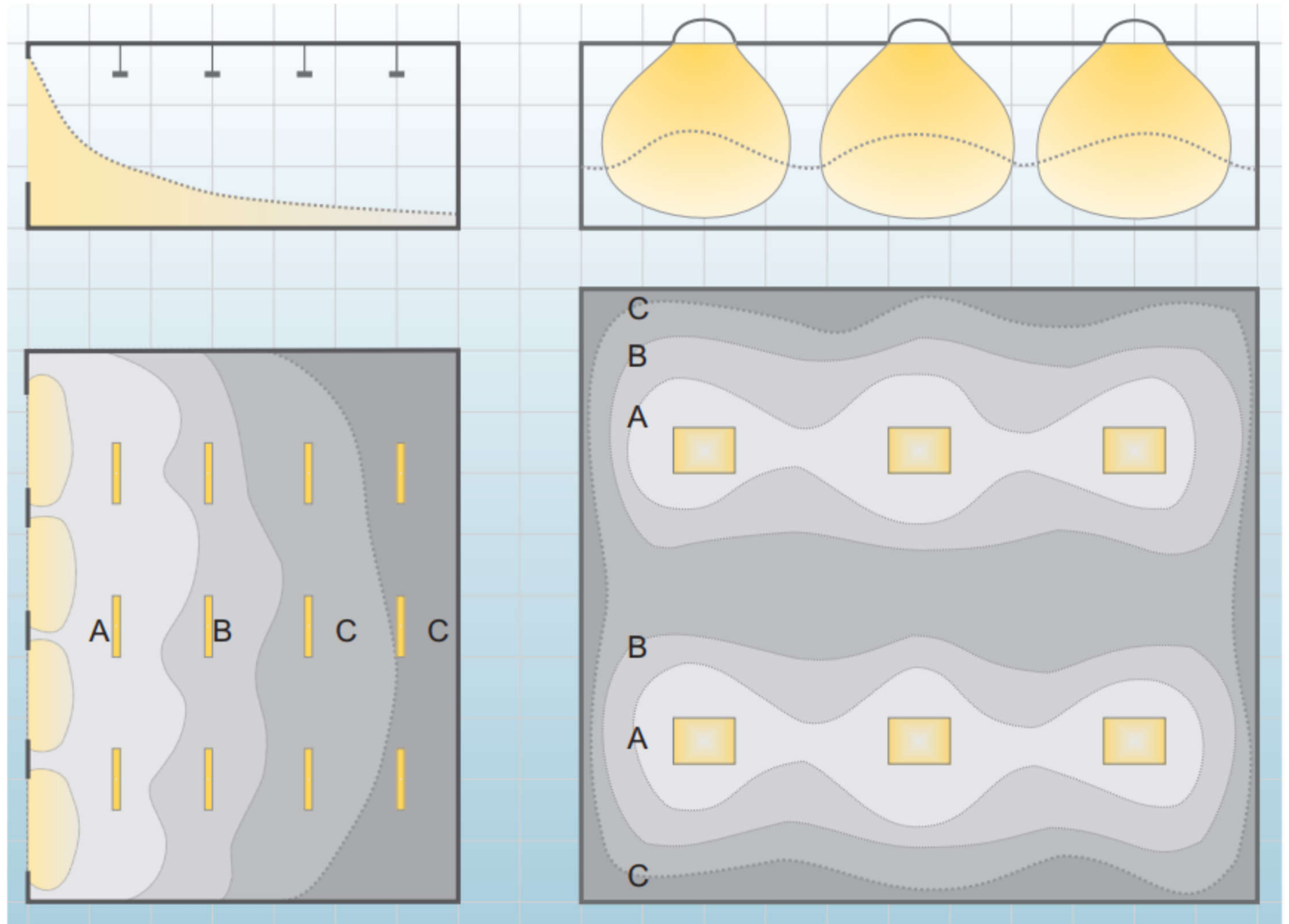

# Shading and controls



- Daylighting control components
  - Electric light sources
  - Photosensor
  - Dimming or switching units
- Placing the photosensor
  - Look directly at a task surface or an interior wall (sense the combination of daylight & electric light)
  - Located on top of a building or view directly out of skylight or window aperture (sense only the available daylight)

# Photodetector based lighting control system

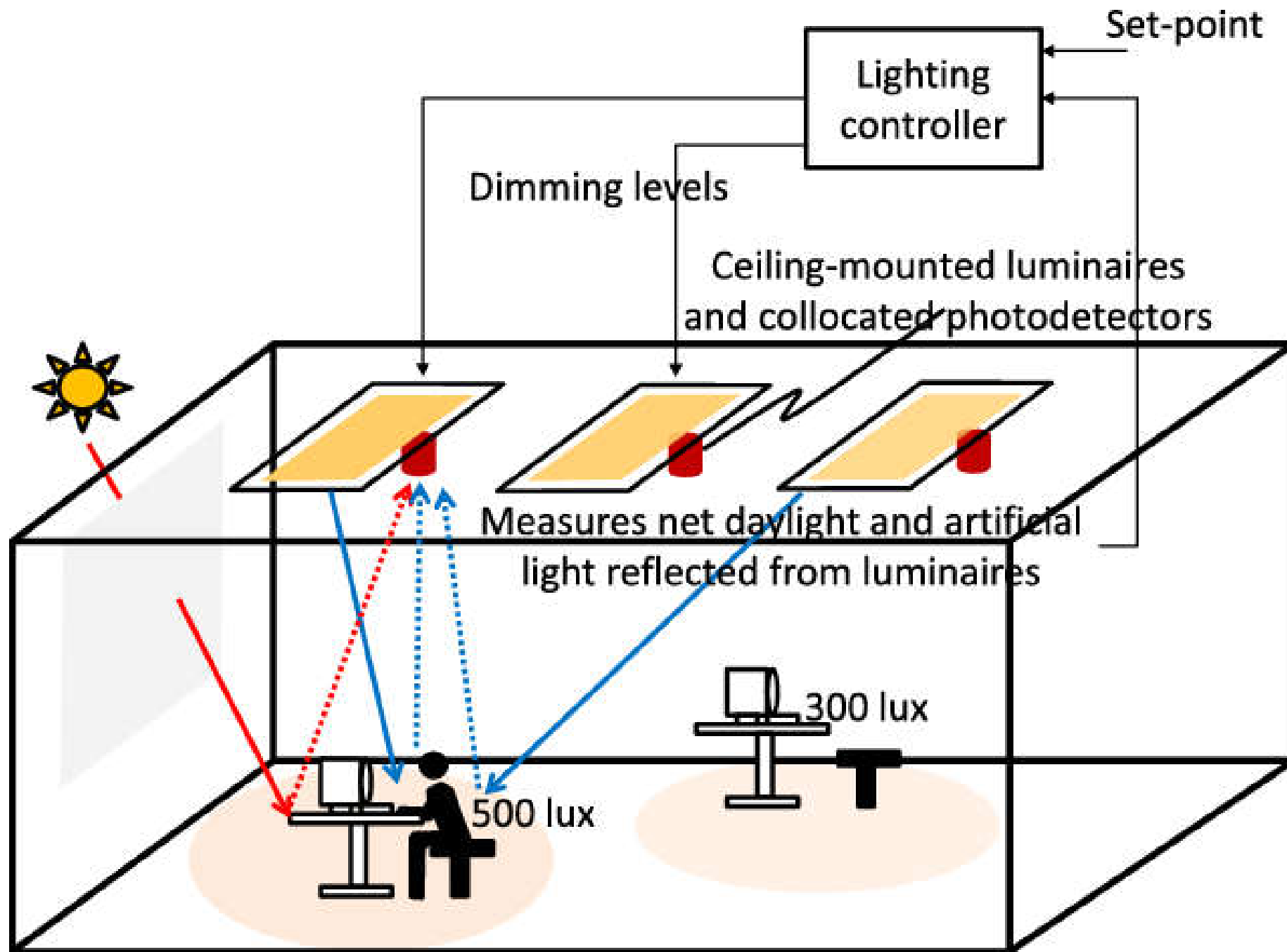

# A room with the profiles of daylight, artificial and total lighting

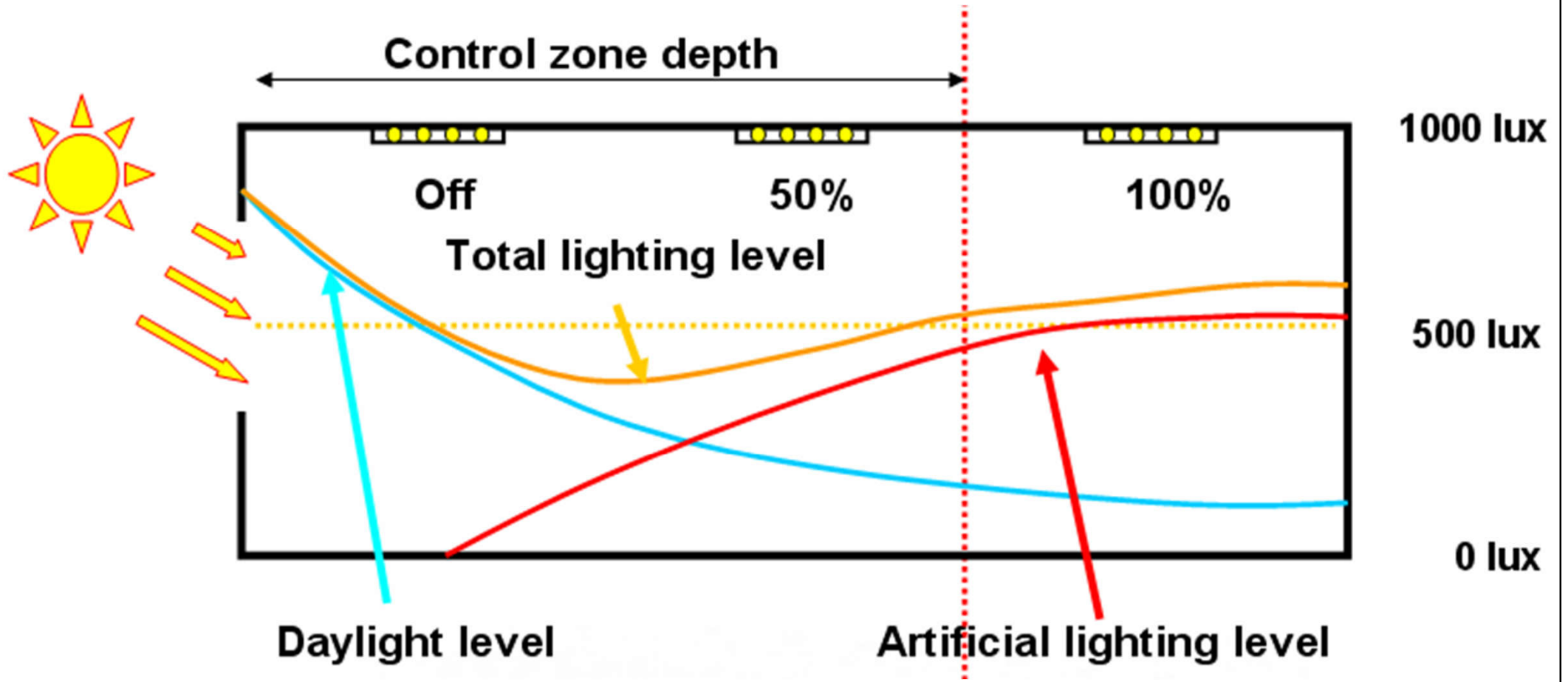

# Switching photosensor illuminance & electric light level with deadbands

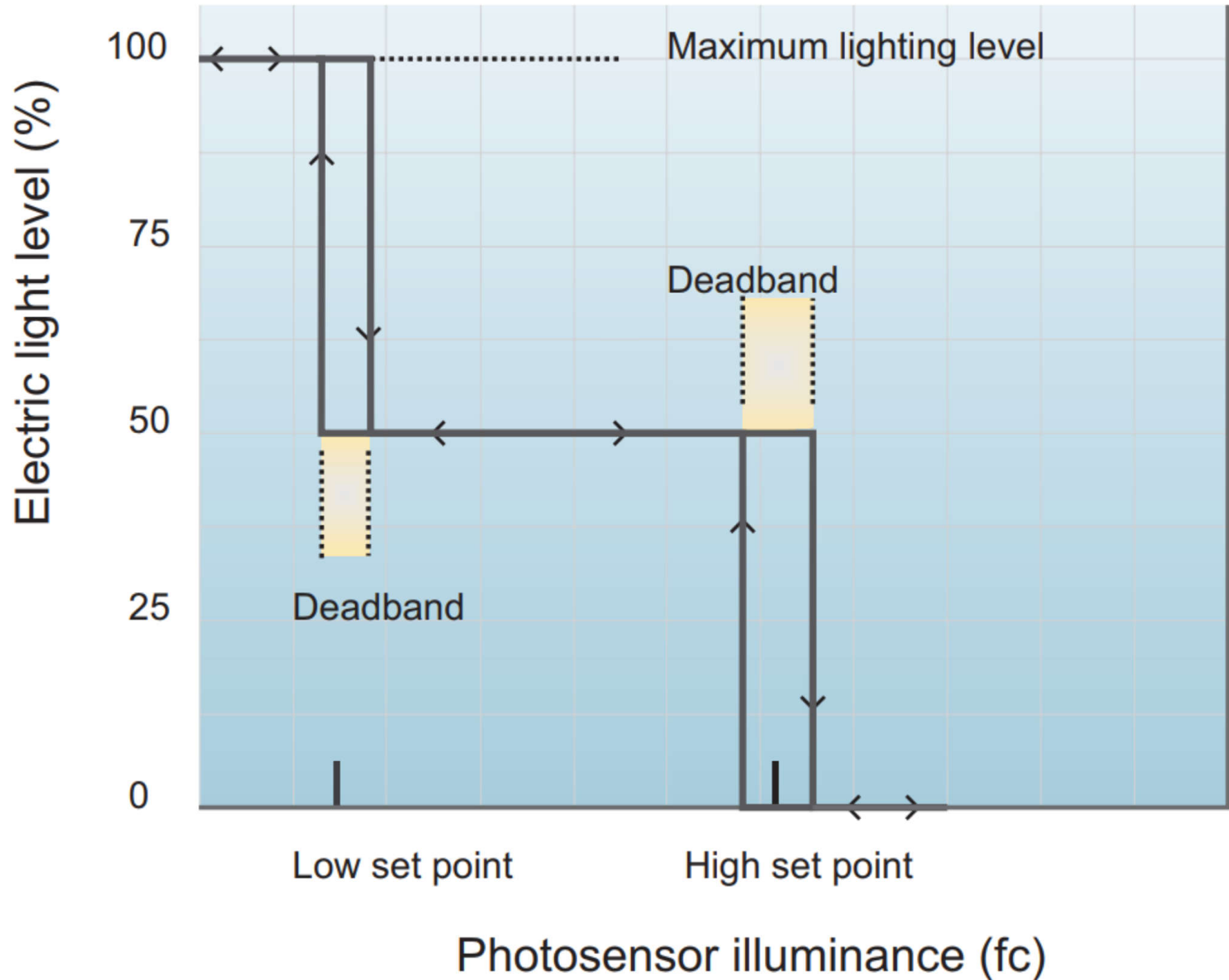

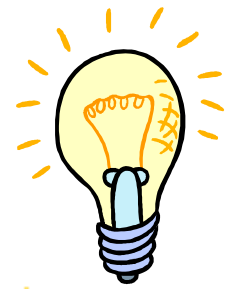

# Further Reading

- Daylight (DEIC Basic Book)  
<https://www.velux.com/what-we-do/research-and-knowledge/deic-basic-book/daylight>
- Daylight Analysis <https://www.newlearn.info/packages/clear/visual/daylight/analysis/>
  - Computer simulations
  - Hand calculations
  - Physical scale models
- Daylight Pattern Guide  
<http://patternguide.advancedbuildings.net/>