

Vertical Transportation (I)

Ir Dr. Sam C. M. Hui

E-mail: sam.cmhui@gmail.com

<http://ibse.hk/cmhui/>

Contents



- Basic Principles
- Planning & Design Factors
- System Types
- Regulations and Codes
- Lift Traffic Analysis
- Advanced Traffic Planning

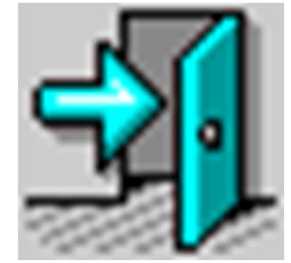

Basic Principles

- Terminology
 - Lifts [UK] = Elevators [US] 升降機/電梯/轆
 - Escalators (moving staircases) 自動扶梯/扶手電梯
 - Conveyors/travelators (moving walkways) 自動行人道

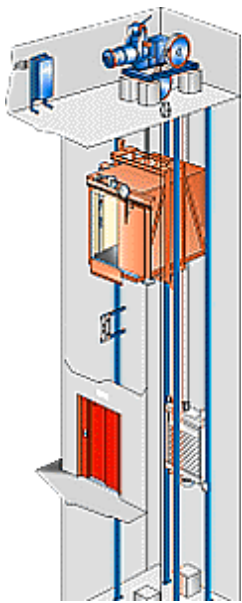

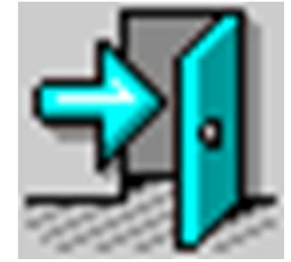

Basic Principles

- History and origins*
 - Hoists & lifting devices in Egypt (2600 BC) for pyramid construction, in China, Greece and Roman Emperor
 - Primitive elevators/lifts operated by human, animal, or water wheel power
 - Power elevators, often steam-operated, were used for conveying materials in factories, mines, and warehouses

Early hoists and turning wheels for agriculture in China

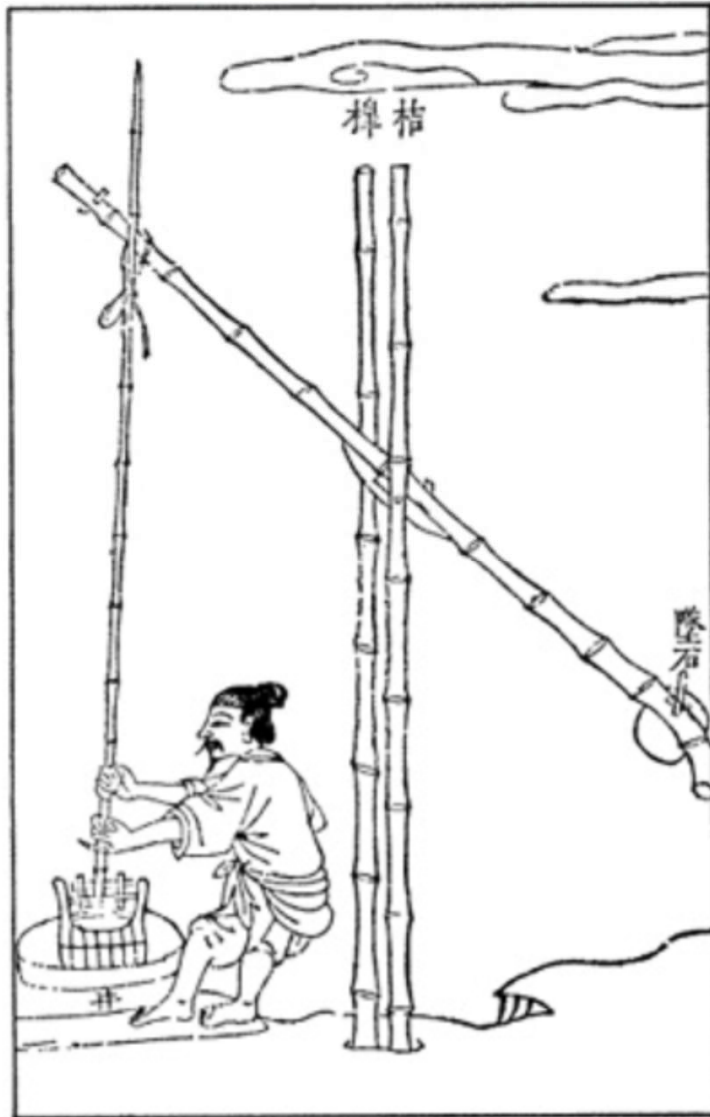

Chinese peasants dipping water from the rivers into irrigation channels using a counterweighted lever made of bamboo.

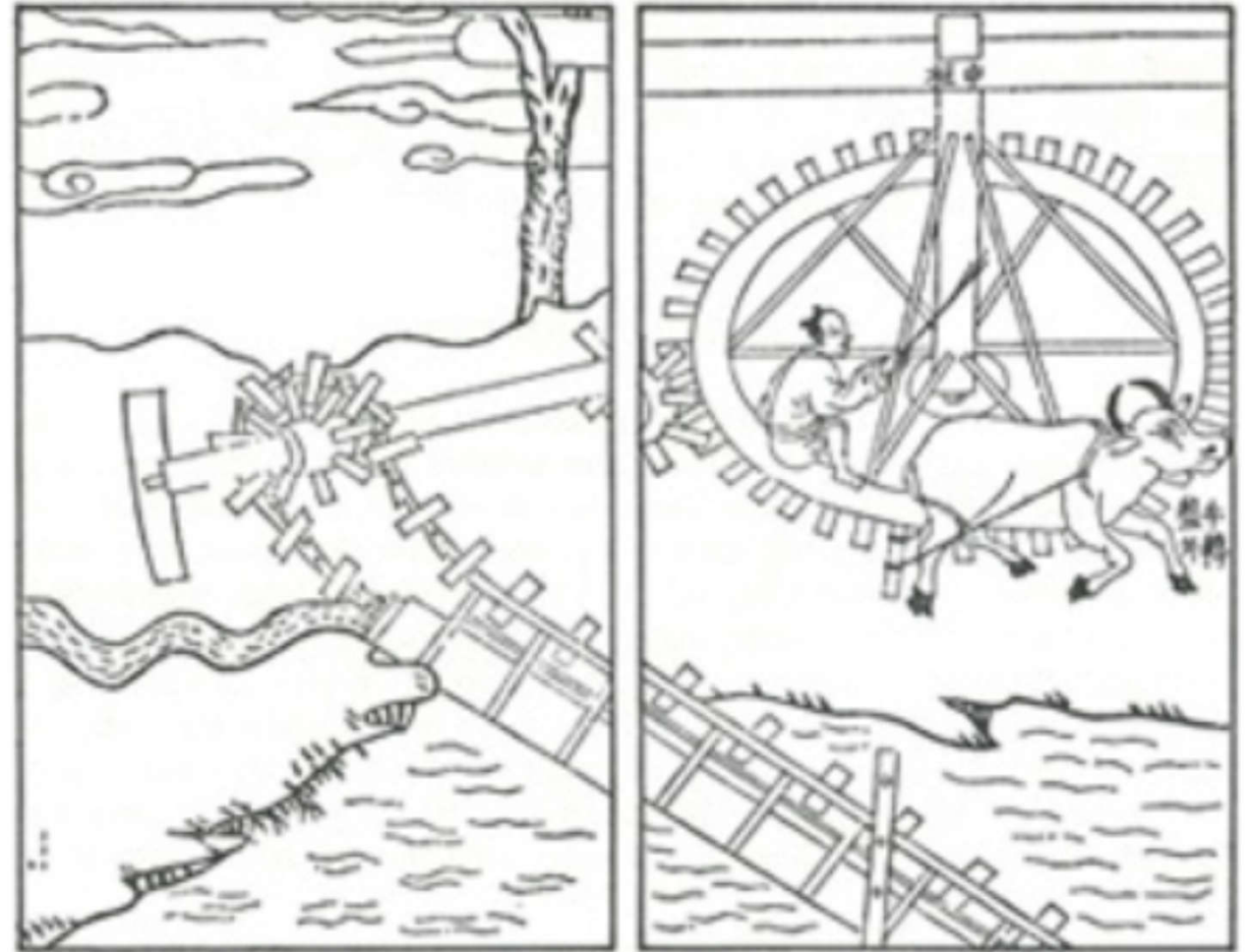

A water buffalo turns the sprocket wheel that, through gearing, brings the water through the pipe to the irrigation channel.

TRANSPORTER HOISTS



The London Dockyards comprised warehouses virtually forming a five or six-story wall along the Thames River. A centrally located steam engine usually provided power to upper-floor "transporter" hoists that raised and lowered goods on one side of a building and similarly served land transport on the reverse side. Many such hoists had the dual purpose of running loads in and out of the warehouse from window loading ledges.

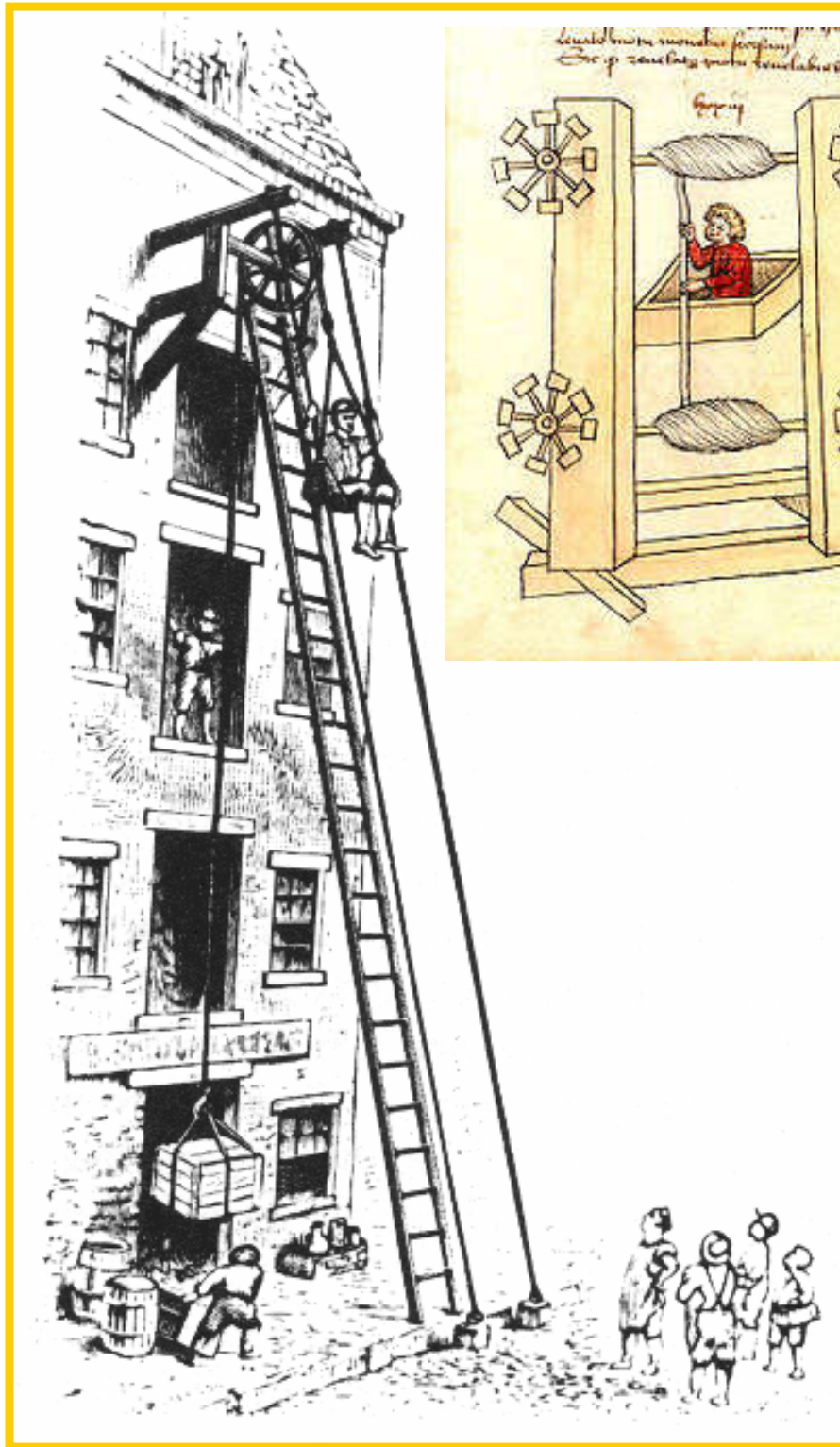

Hoists (early form of lift system)

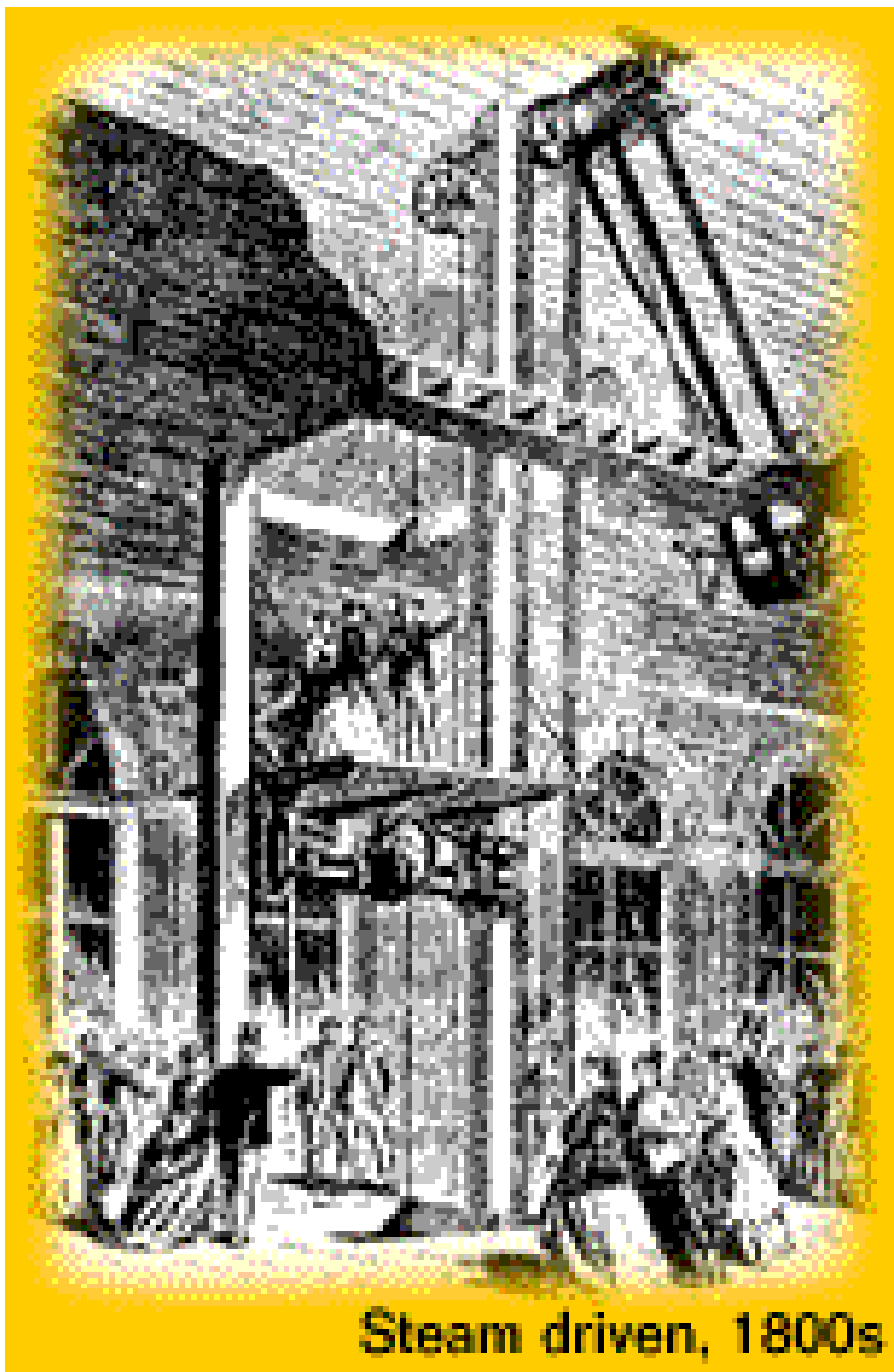

Steam driven, 1800s

Power elevator (steam)

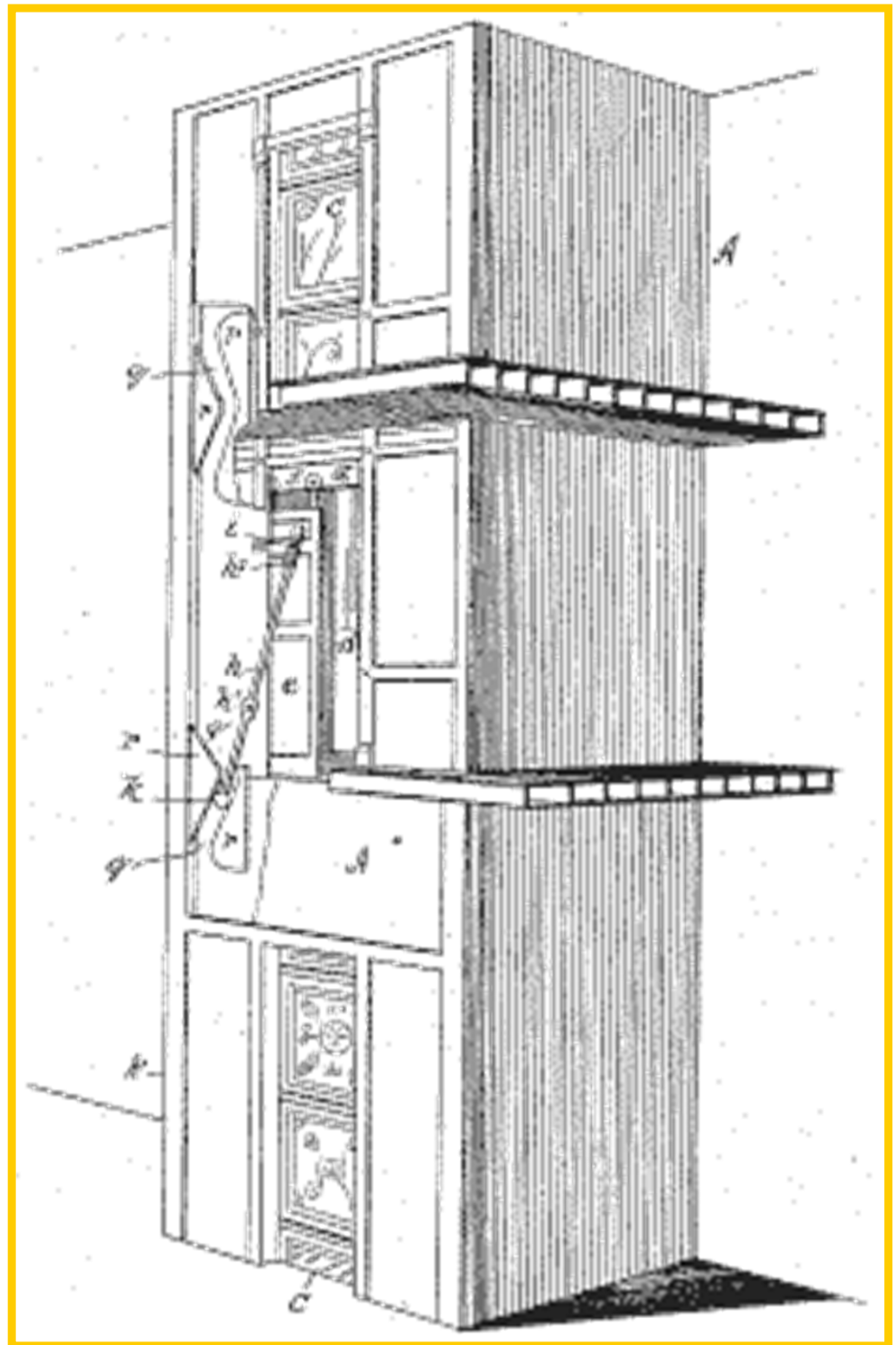

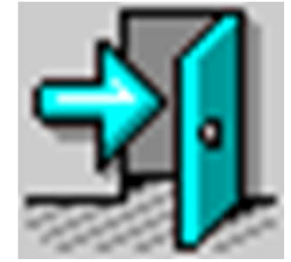

Basic Principles

- History of modern elevators/lifts*
 - In 1846, Sir William G. Armstrong introduced the hydraulic crane, and in the early 1870s, hydraulic machines began to replace the steam-powered elevator
 - In 1853, Elisha G. Otis demonstrated a freight elevator equipped with a safety device to prevent falling. He then established a company to manufacture hoists and elevators
 - In 1880, the first electric elevator was built by the German inventor Werner von Siemens

Lift introduced in 1856 (left, speed 0.2 m/s) and the one installed in Shanghai Tower (right, speed 18 m/s)



Shanghai Tower (128-story, 632-meter) (express & local lifts serve the 9 zones of the tower)

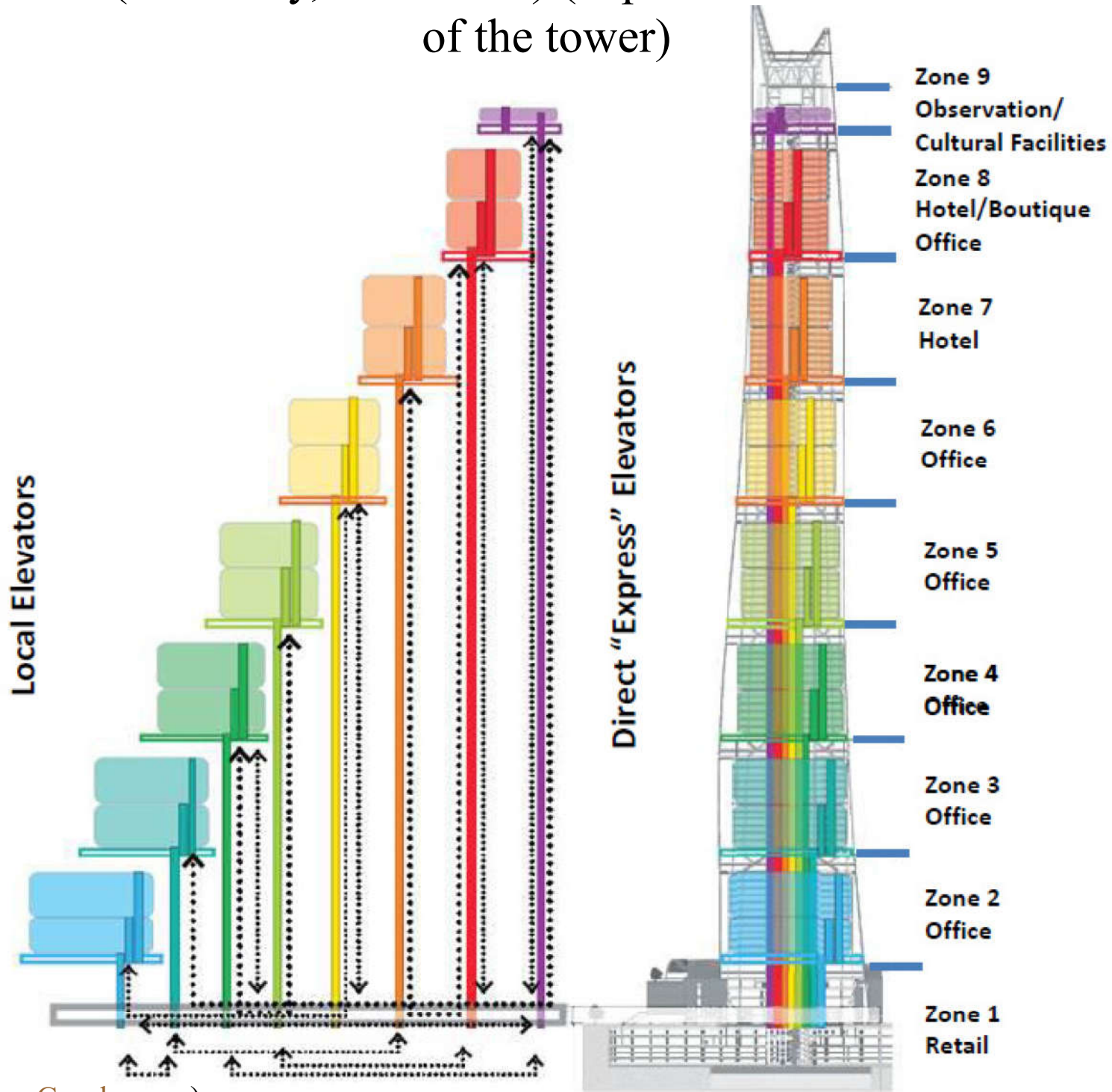

Tall buildings are not possible without lifts and escalators* (these are examples of tall buildings that I have visited)

296 m (1993)



Landmark Tower,
Yokohama, Japan
(max. lift speed
750 m/min or
12.5 m/s)

367 m (1990)



Bank of China
Building,
Hong Kong

374 m (1992)



Central Plaza,
Hong Kong

415 m (2003)



International
Finance Centre
Two (IFC-2),
Hong Kong

484 m (2010)



International
Commerce Centre
(ICC),
Hong Kong

(*See also: Lifts and Escalators -- statistics, history and design data http://ibse.hk/IBTM6010H/Lifts-Escalators_statistics_history_design_data.pdf; World and HK Records http://www.hkelev.com/oth_recond.htm; Examples of lift systems for highrise buildings in Hong Kong: [[Example1](#)][[Example2](#)][[Example3](#)])

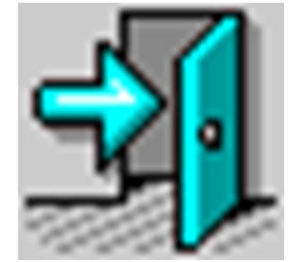

Basic Principles

- “Escalator” = “Elevator” + “Scala” (steps)
 - First escalator: designed by Jesse Reno in 1892



Ocean Park (longest outdoor escalator, total 220 m)



Central-Mid-Levels Escalator, total 790 m

(See also: <https://www.designingbuildings.co.uk/wiki/Escalator>)

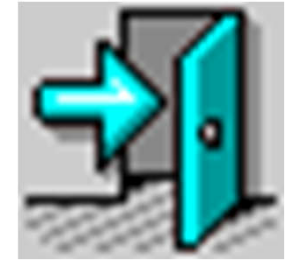

Basic Principles

- Principles of operation
 - How Elevators Work
 - <http://www.howstuffworks.com/elevator.htm>
 - How Escalators Work
 - <http://www.howstuffworks.com/escalator.htm>
- Videos for demonstration:
 - How Elevator Works (3:47) <https://youtu.be/CeOk1EyUw0I>
 - How does an Escalator work? (4:58) <https://youtu.be/1jfNIBtfWDY>



Power flow through a typical elevator

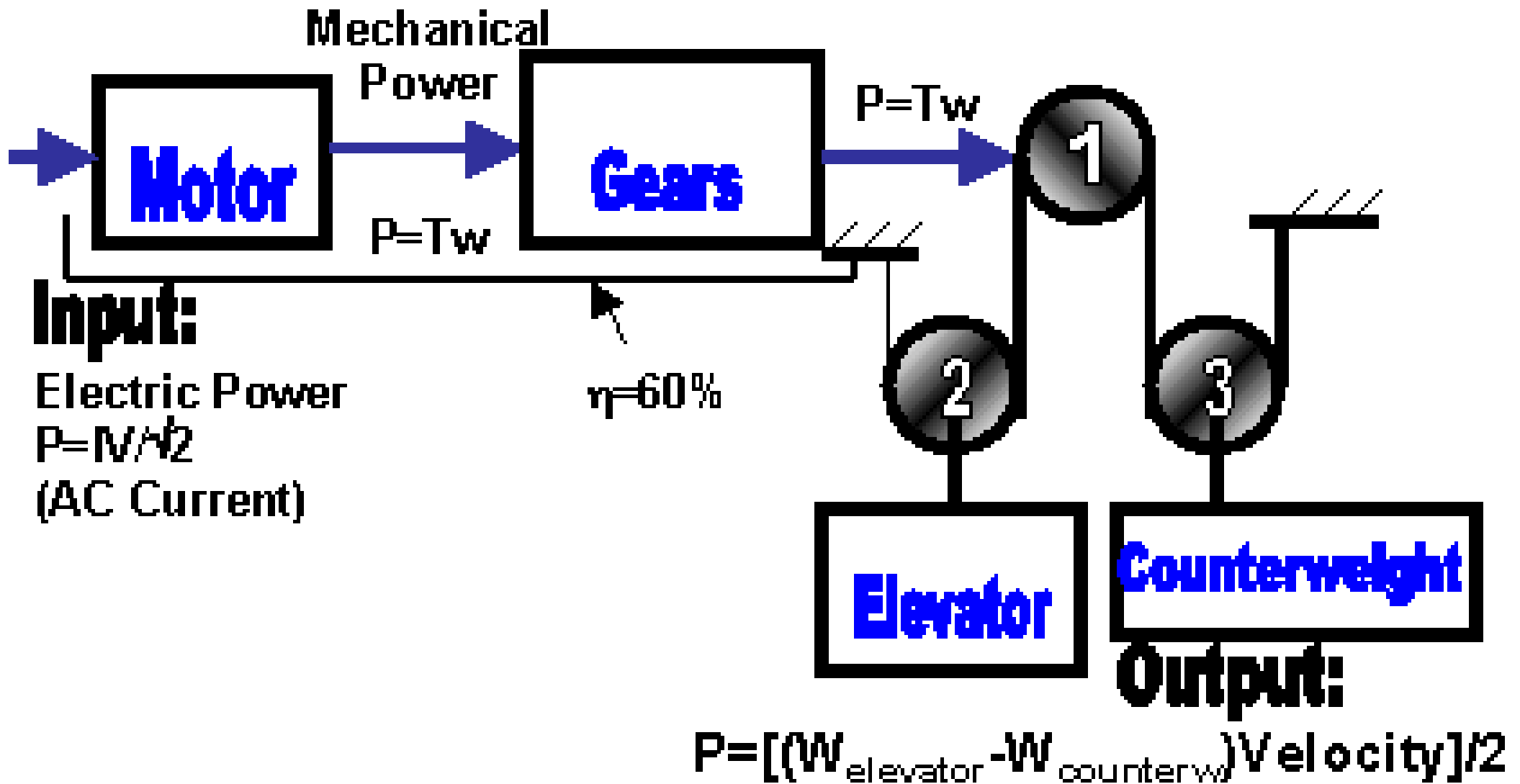

How Escalators Work

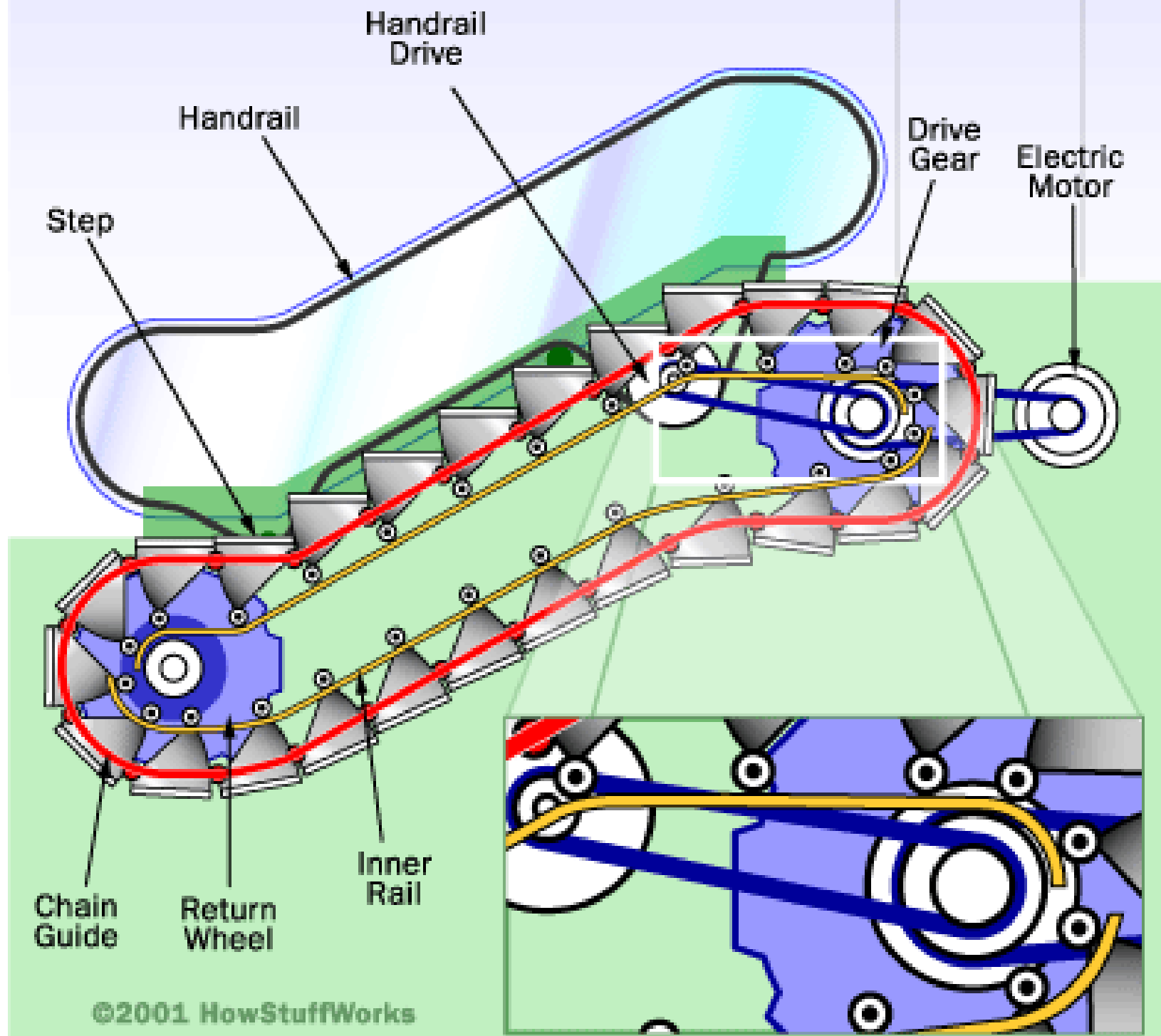

©2001 HowStuffWorks

Steps of an escalator



© 2001 HowStuffWorks

(Video: Escalator Animation (2:24) <https://youtu.be/UTcPsBqsavk>)

[Image source: <http://www.howstuffworks.com/>]

Planning & Design Factors



- Circulation/Movement of people in buildings
 - Mode (horizontal or vertical)
 - Movement type: natural (passive), attendant assisted (active) or mechanically assisted (active)
 - Human behaviour (complex, unpredictable)
- Design objectives
 - Free flow of people & goods
 - Safe operation, comfort & service
 - Occupy minimum space & require less costs
 - Aesthetics, disabled access, etc.

Planning & Design Factors



- Circulation elements in buildings include:

- Spaces & corridors
- Portals (e.g. entrance, door, gate)
- Stairways
- Ramps

Passive circulation elements (physical or architectural)

- Lifts
- Escalators
- Moving walkways

Active circulation elements (mechanical or engineering)

* Can you identify them in a building?

Typical floor plan of a commercial building

Can you find out all the circulation elements?

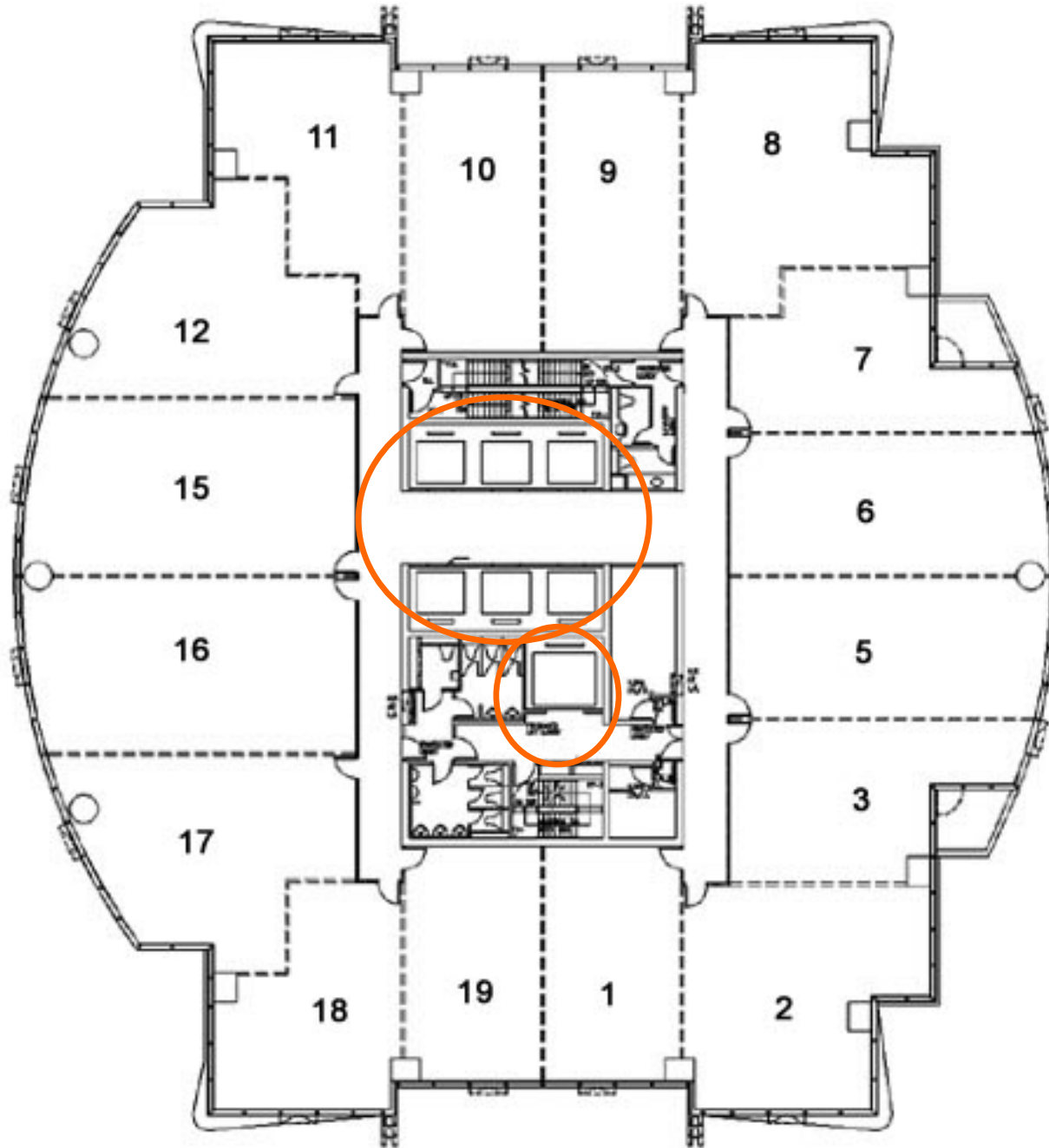

G/F plan of a commercial building

Can you find out all the circulation elements?

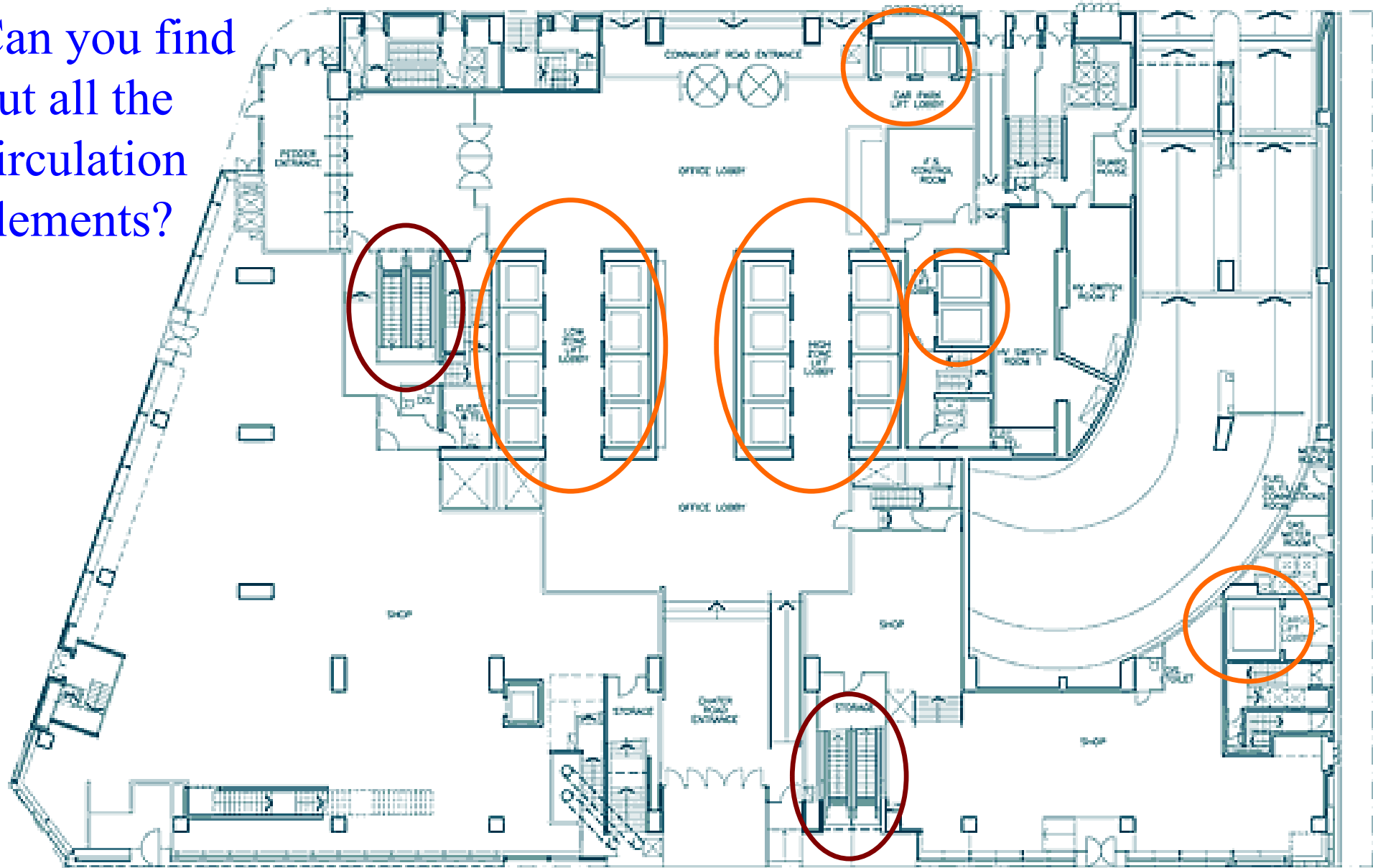

Planning & Design Factors

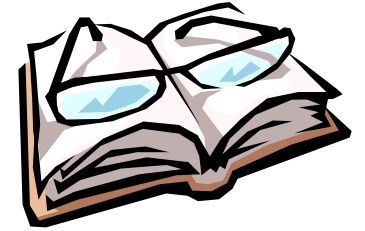

- Efficiency of interior circulation depends on
 - Relative location of rooms
 - Relationship of major spaces with entrances & people handling equipment
 - Importance of journey undertaken (e.g. hospital)
 - Separation of different traffic types (e.g. clean/dirty)
 - The need to group some spaces together
 - Conflict of vertical & horizontal circulation modes

Planning & Design Factors



- Human factors

- 1. Physical dimensions & weight
 - Occupancy ellipse (assume male subject)
 - 600 mm by 450 mm (0.21 m²)
 - Weight: 75 kg (world average = 62 kg)
- 2. Personal space (buffer zone)
 - Female: 0.5 m² (0.8 m diameter circle)
 - Male: 0.8 m² (1.0 m diameter circle)
 - Compared w/ size of an umbrella

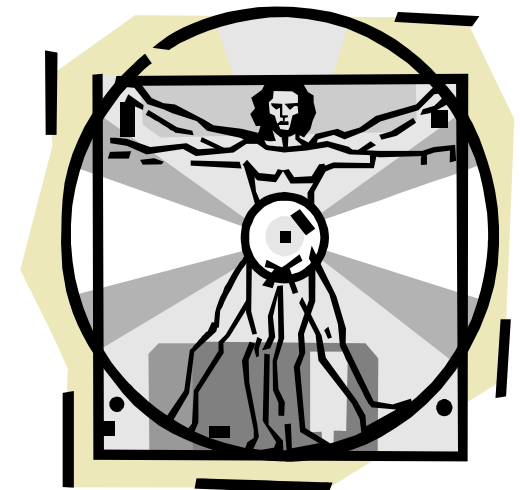

Typical occupancy ellipse (a male subject)

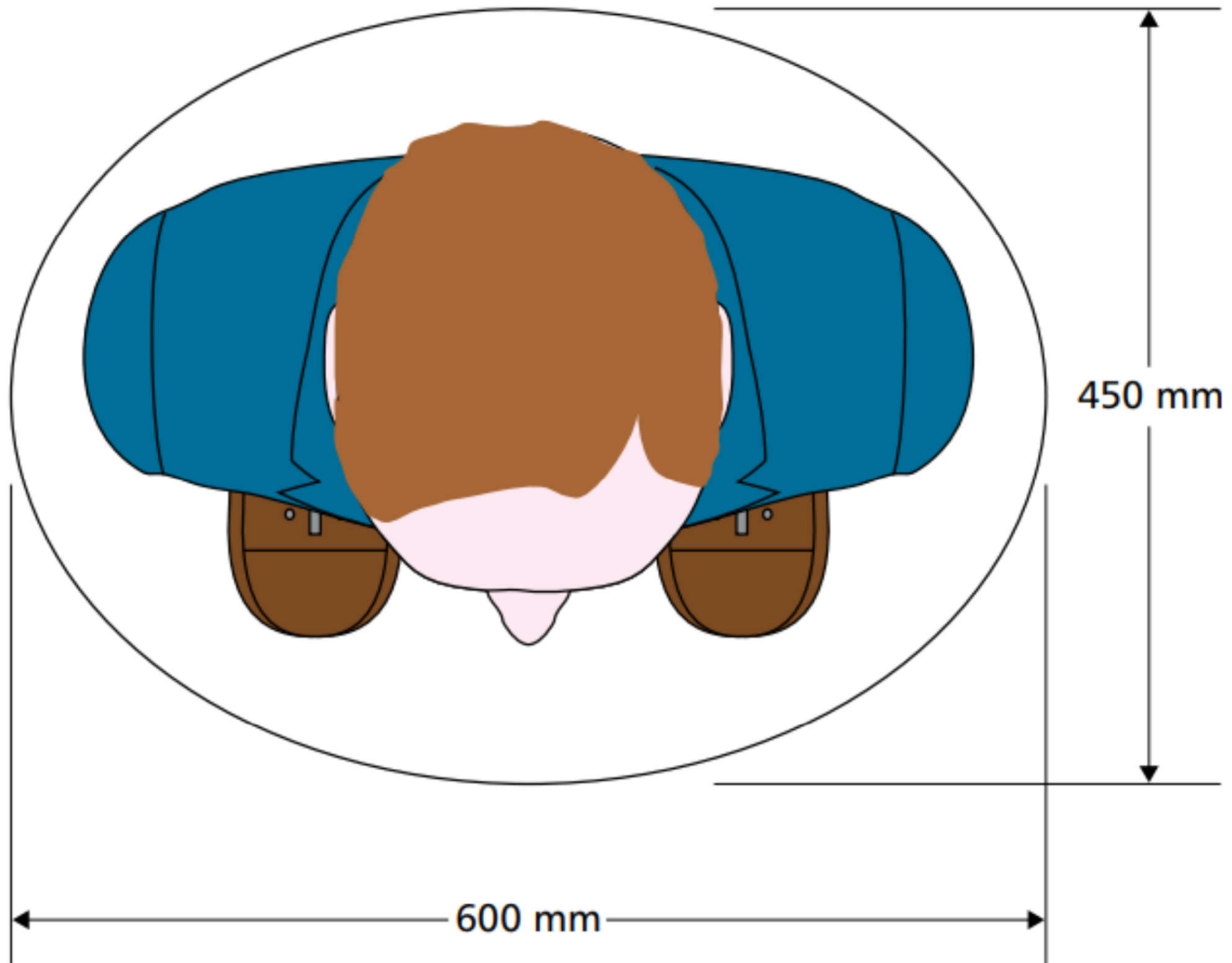

[Source: CIBSE Guide D]

Planning & Design Factors

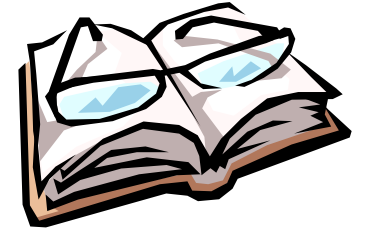

- Human factors (cont'd)
- 3. Density of occupation
 - Desirable: 0.4 person/m²
 - Comfortable: 1.0 person/m²
 - Dense: 2.0 person/m²
 - 'Crowding': 3.0 person/m²
 - Crowded: 4.0 person/m²

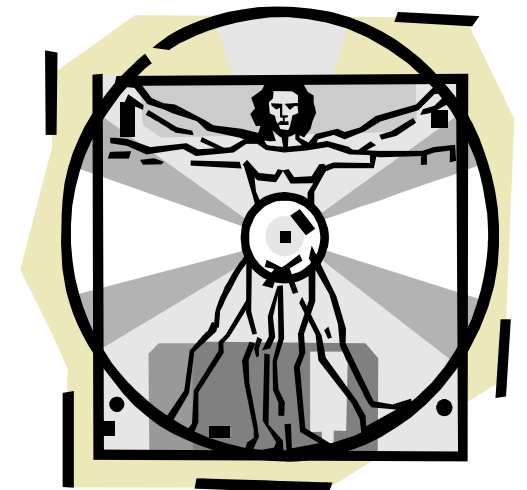

Planning & Design Factors



- Human factors (cont'd)

- 4. Interpersonal distances

- Public distance: > 7.5 m (far); 3.6-7.5 m (near)
- Social distance: 2.1-3.6 m (far); 1.2-2.1 m (near)
- Personal distance: 0.75-1.2 m (far); 0.45-0.75 m (near)
- Intimate distance: < 0.45 m

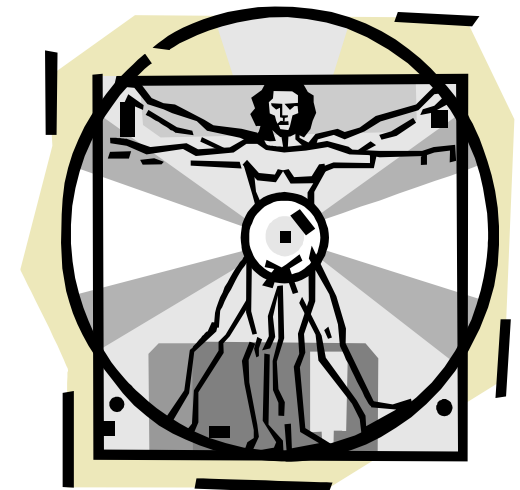

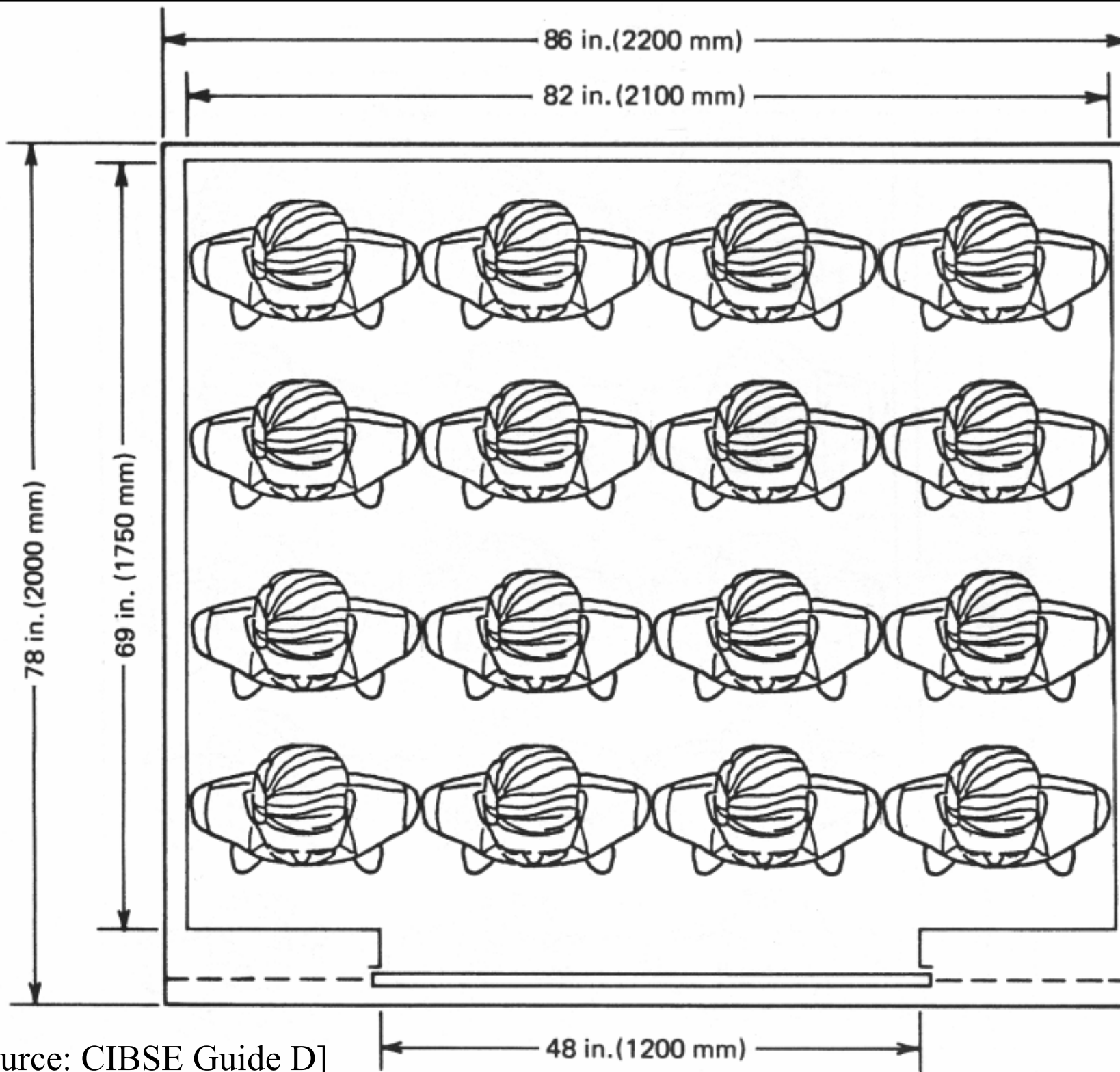

[Source: CIBSE Guide D]

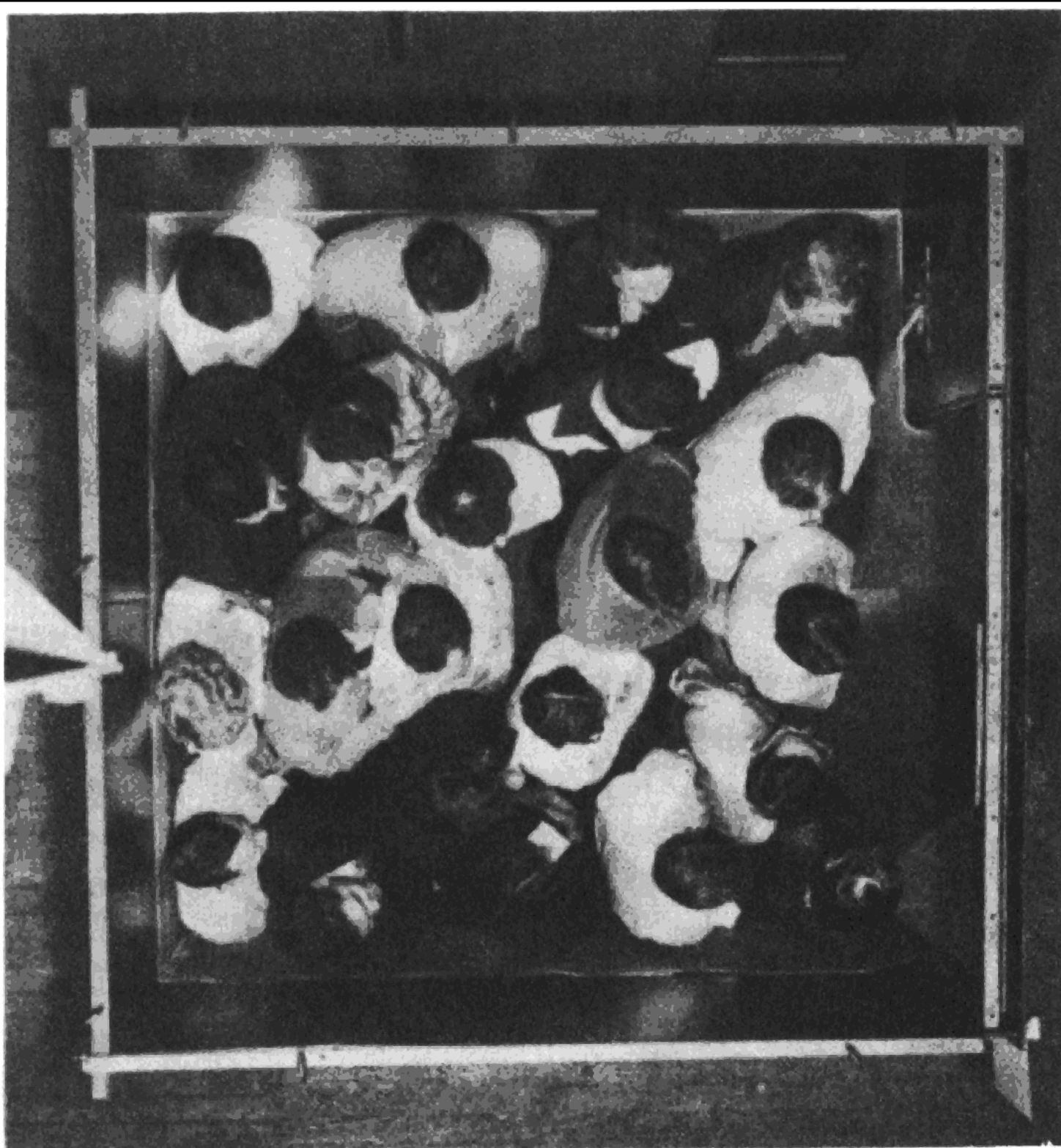

Actual
situation

[Source:
Strakosch,
G. R., 1998.
The Vertical
Transportat-
ion
Handbook]

Planning & Design Factors



- Major design concerns
 - Circulation efficiency
 - Location & arrangement (prevent bottlenecks)
 - Coordination with lobby, stairway & corridor
 - Fire & safety regulations
 - Quantity of service (e.g. handling capacity)
 - Quality of service (e.g. interval or waiting time)
- Consideration by lift functions
 - Passenger, goods, firemen, shuttle, observation

Passenger lifts within a fire fighting shaft (with a protected lift lobby)

Self-closing fire doors with smoke seal

Fire door (one hour rated)

Fire fighting lobby

Lift landing door with fire resistance without smoke seal

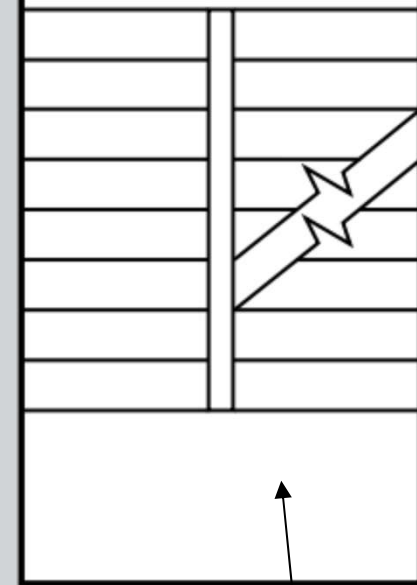
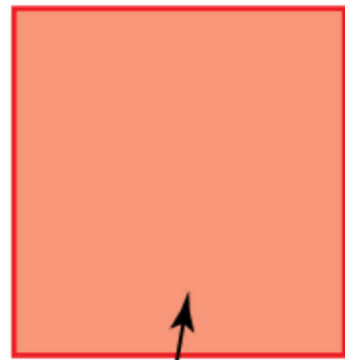
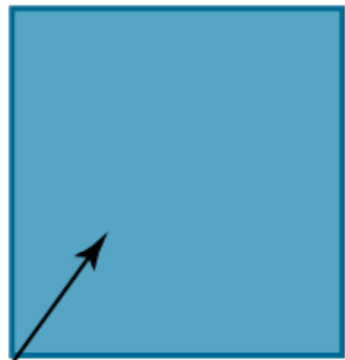

Passenger lifts

Firefighters lift

Staircase
(escape route)

Planning & Design Factors

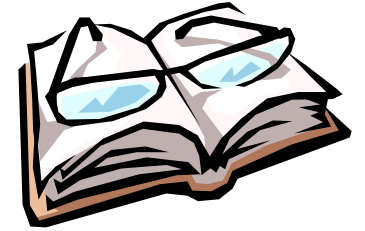

- Consideration by building function
 - Offices (various classes)
 - Airports, railway stations
 - Shopping centres, department stores, car parks
 - Sports centres, concert halls
 - Hospitals, hotels, universities (institutional)
 - Residential, dormitory
- Types of occupancy
 - Single or multiple tenants; nature of business

Planning & Design Factors

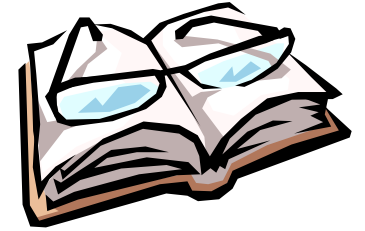

- Planning of lifts
 - Shall commence early in the project
 - Consider the positions of entrances & staircases
 - With a number of passenger lifts, they should be grouped together
 - Lift lobby must be wide enough
 - For tall buildings, express lifts may be required

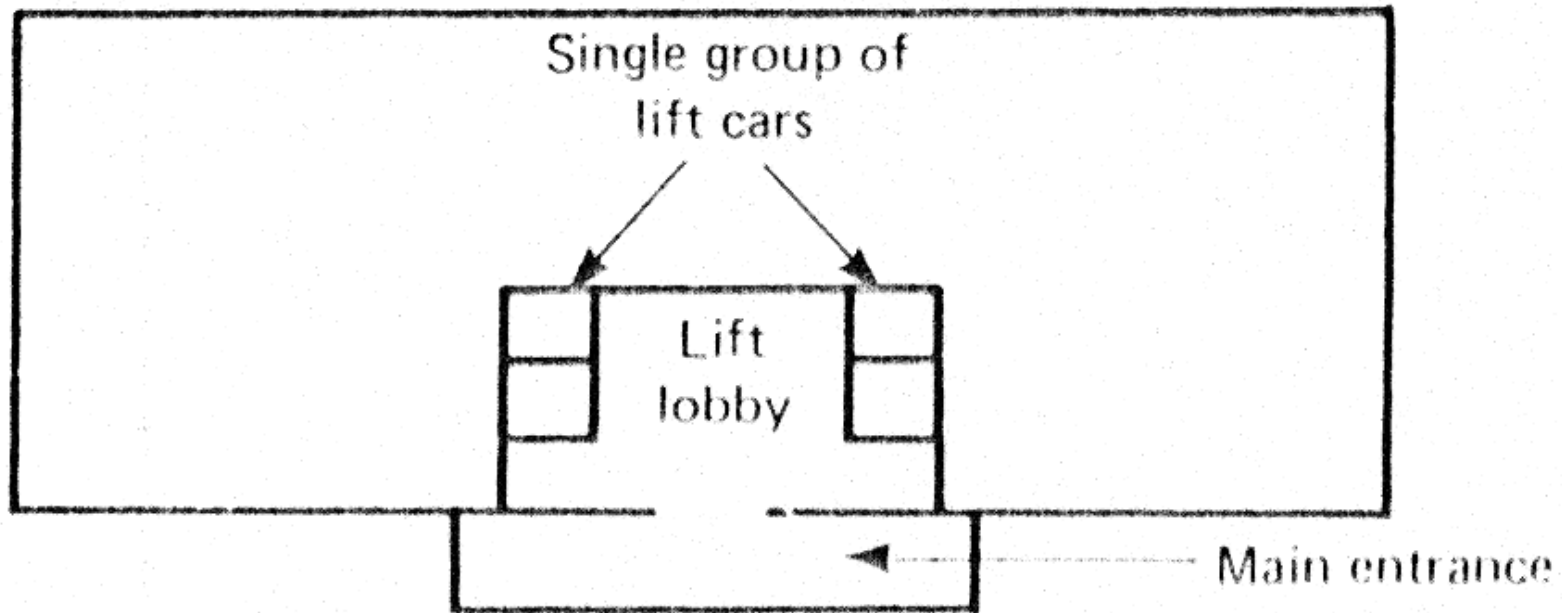

Fig 1 Building with a single group of lifts

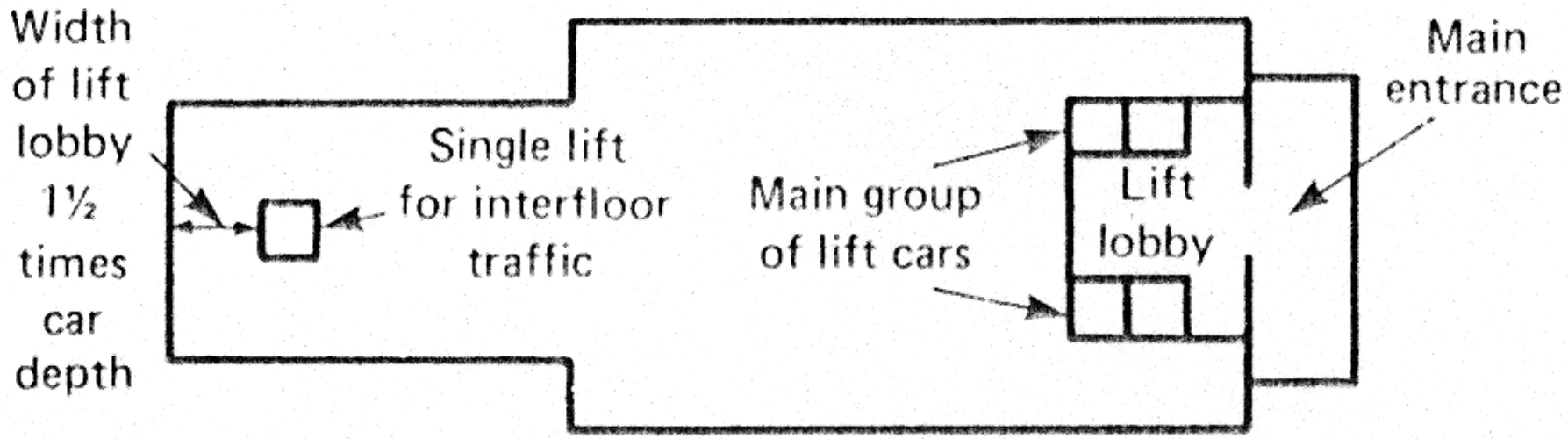
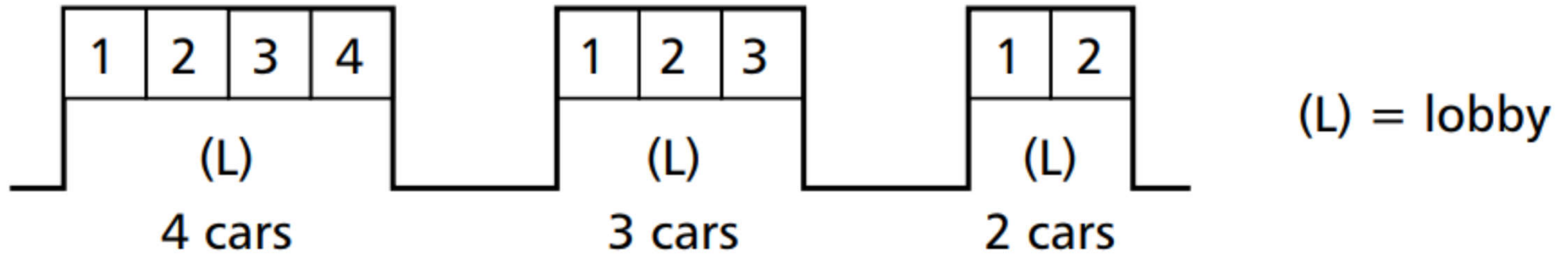

Fig 2 Building with a main group of lifts and also a single lift serving interfloor traffic

[Source: Building Services Handbook]

Preferred arrangements for lifts



(a) For 2 to 4 lifts: in line

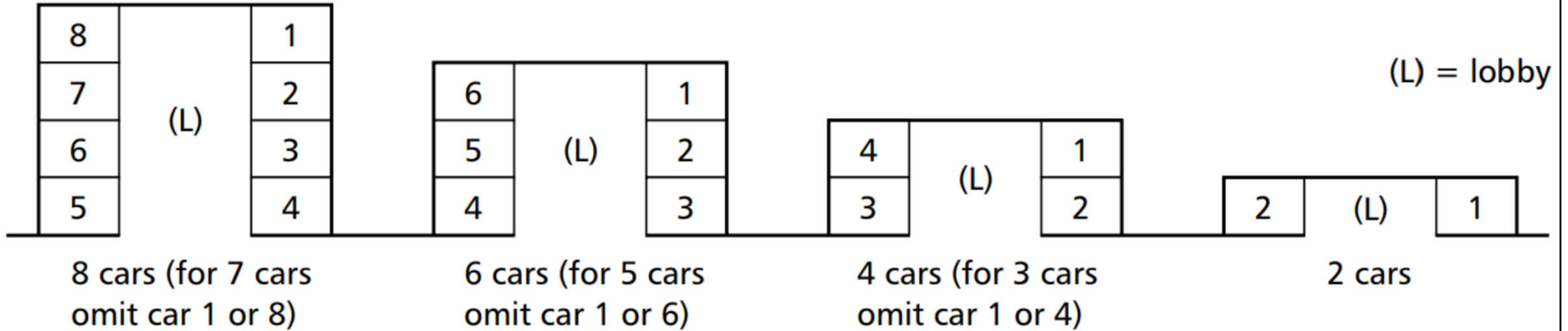

(a) For 2 to 8 lifts: facing

Lift configuration of World Trade Center (New York)

- KEY:**
- █ express to top
 - █ express to skylobbies
 - █ local service
 - █ skylobby floors
 - █ mechanical floors
 - █ escalators
 - █ floor stops

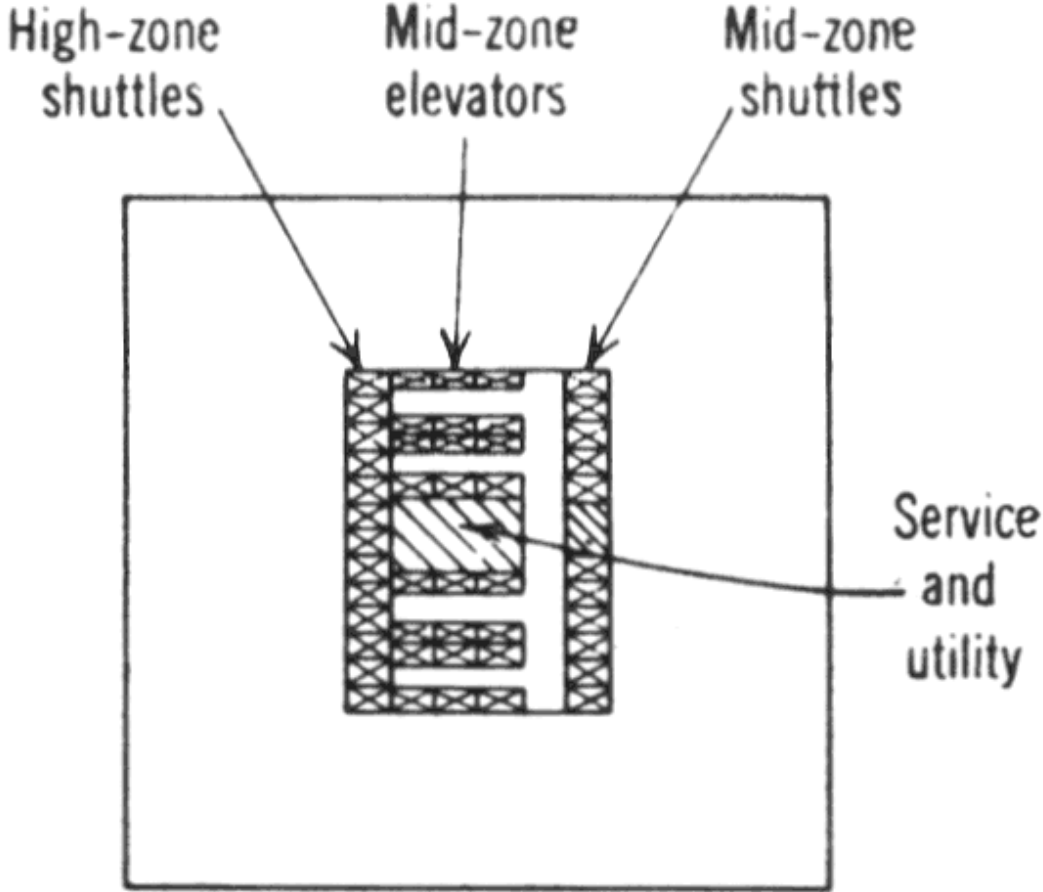
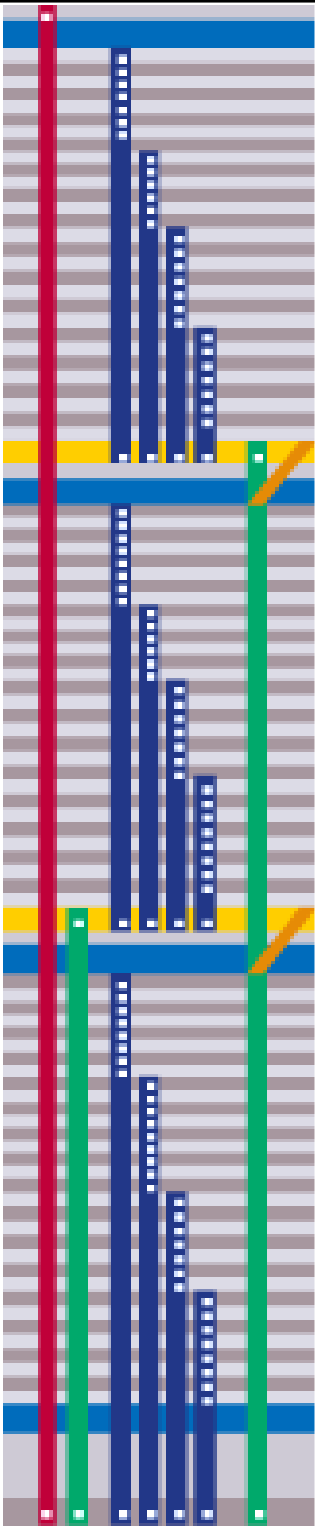

Lift system of World Trade Center (New York)

System Design Concept

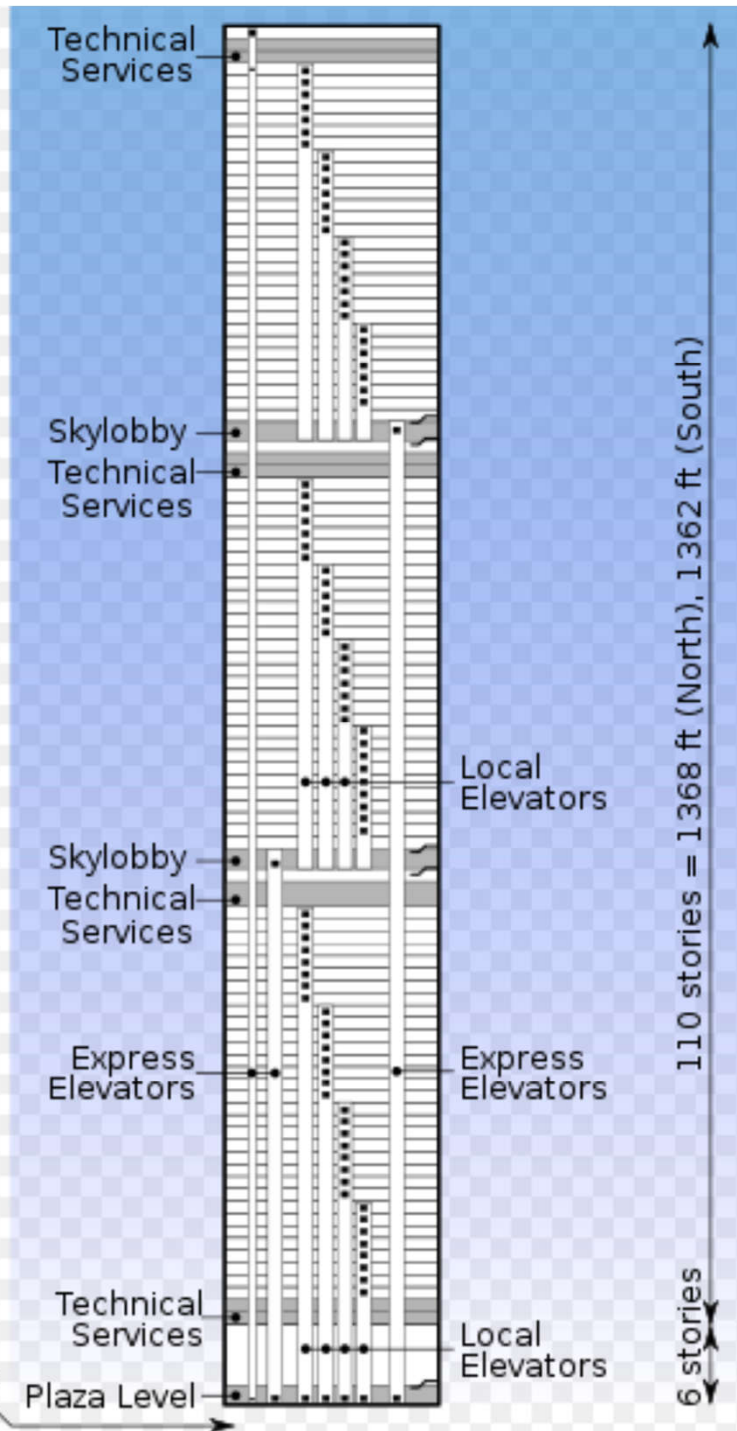
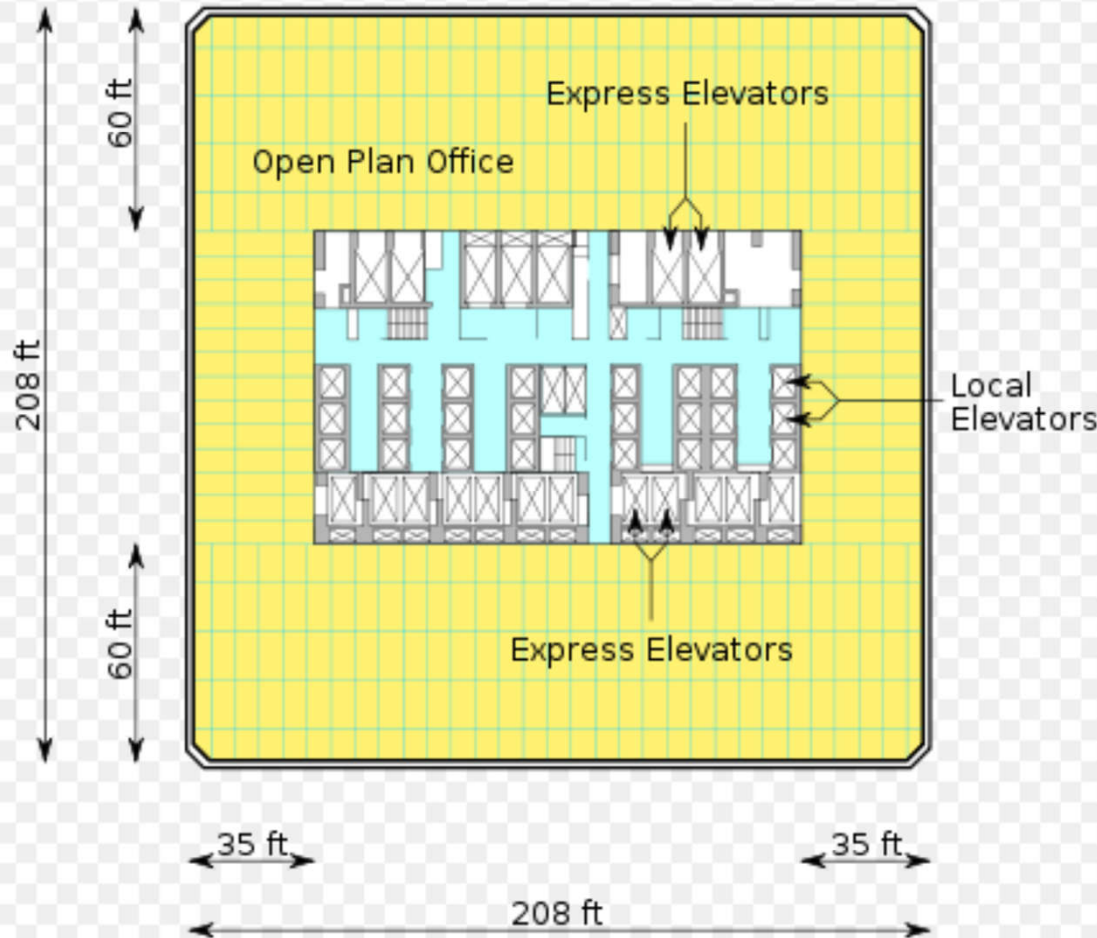

Planning & Design Factors



- Escalator – typical design
 - Speed: 0.5 and 0.65 m/s, up to 0.9-1.0 m/s on deep systems like subway
 - Step widths: 600, 800 & 1000 mm; min. step or tread length = 400 mm
 - Inclination: usually at angle 30°
 - 35° if rise < 6 m & speed < 0.5 m/s
 - Boarding and alighting areas
 - Safe boarding, 1.33 – 2.33 flat steps



Typical escalator design

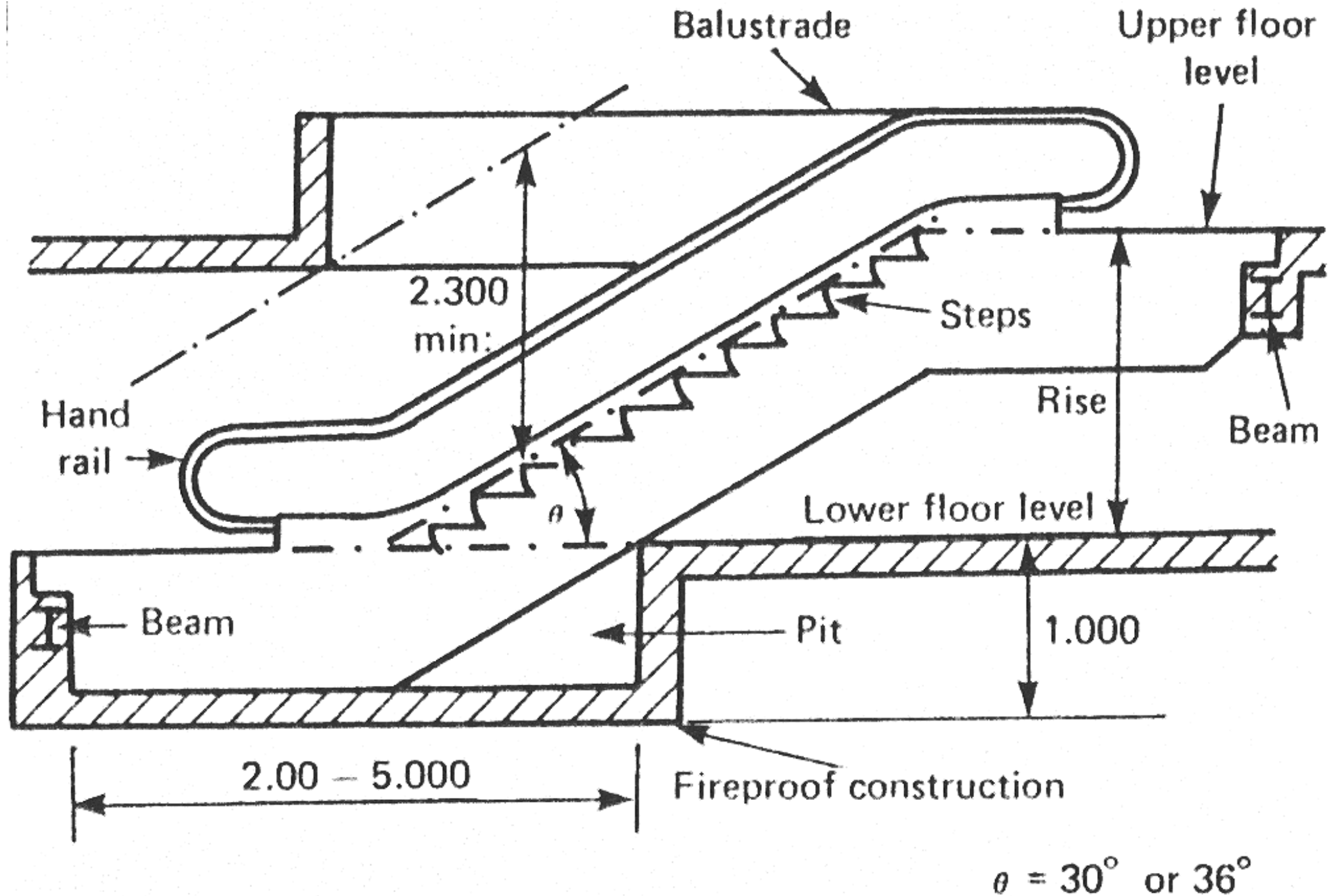

[Source: Building Services Handbook]

Planning & Design Factors



- Escalator – typical applications
 - Low- to medium-rise buildings
 - Large no. of people e.g. airports, subway stations, department stores, shopping malls
- Escalator arrangements
 - Parallel
 - Multiple parallel
 - Cross-over or criss-cross
 - Walkaround

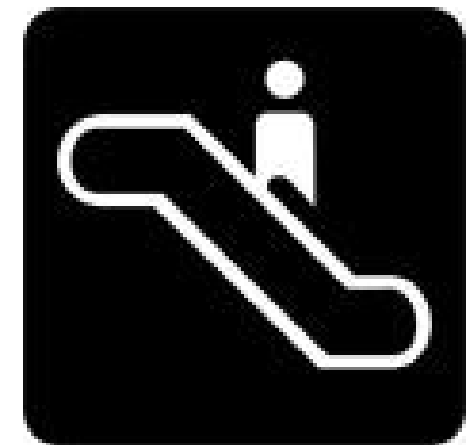

Escalator configurations

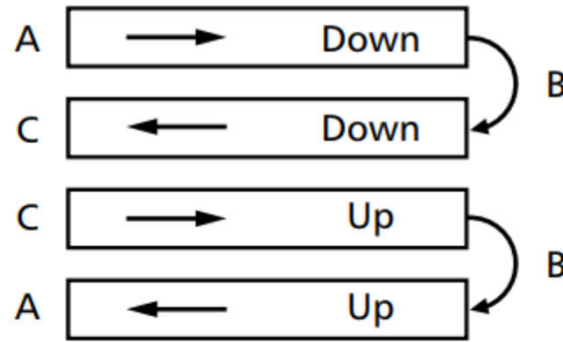
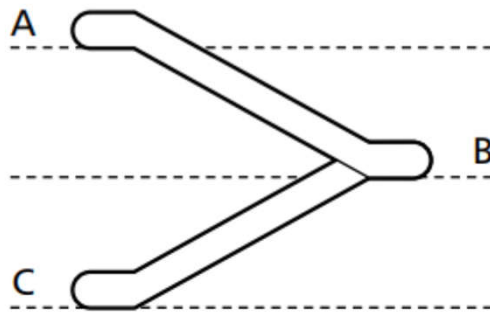

Parallel

(a)

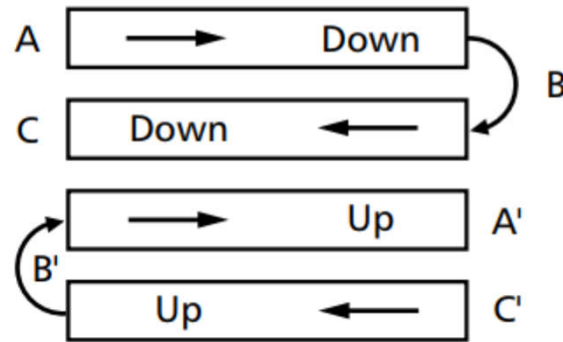
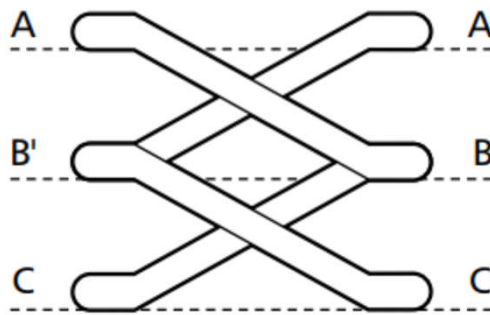

Cross over

(b)

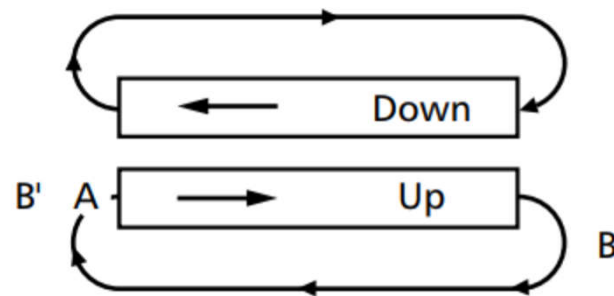
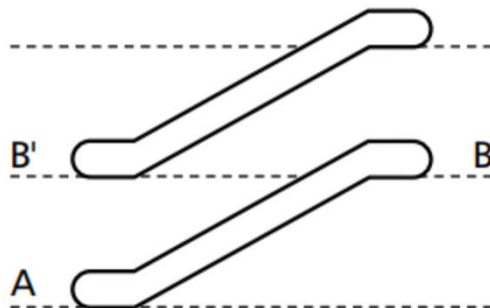

Walk round

Planning & Design Factors



- Escalator: handling capacity
 - $N = (3600 \times P \times V \times \cos \theta) / L$
 - N = no. of persons moved per hour
 - P = no. of persons per step
 - V = escalator speed (m/s)
 - L = length of step (m)
 - θ = angle of incline
 - $C_e = 60 V k s$ (persons/minutes)
 - V = speed along the incline (m/s)
 - k = average density of people (people/step)
 - s = number of escalator steps per metre



Planning & Design Factors



- Comparison of lifts and escalators
 - Lifts: for “long distance” travel over a large number of floors; most effective for tall buildings
 - Escalators (or stairs): for travel over a small number of floors (e.g. shopping centres, railway stations); most effective for handling large people flow
- A building complex could use both lifts and escalators to get the best results

Comparison of different types of lift & escalator systems

| Type of system | Typical applications | Advantages | Disadvantages |
|-------------------------------------|-----------------------------|--|--|
| Hydraulic | Low rise 2-6 floors | Low cost | Slow, high energy use, maintenance issues |
| Traction machine room-less | Low-Mid rise 2-10 floors | Easy installation, energy savings, faster then hydraulic option | Higher cost than hydraulic option |
| Traction geared | Mid rise 3-25 floors | Low cost for application | Speed, energy consumption |
| Traction gearless (direct drive) | High rise over 25 floors | High speed | High cost |

Likely division of traffic
between lifts & escalators

| Floor travelled | Escalator | Lift |
|-----------------|-----------|------|
| 1 | 90% | 10% |
| 2 | 75% | 25% |
| 3 | 50% | 50% |
| 4 | 25% | 75% |
| 5 | 10% | 90% |

[Source: CIBSE Guide D]

Typical range of rises for different lift technologies

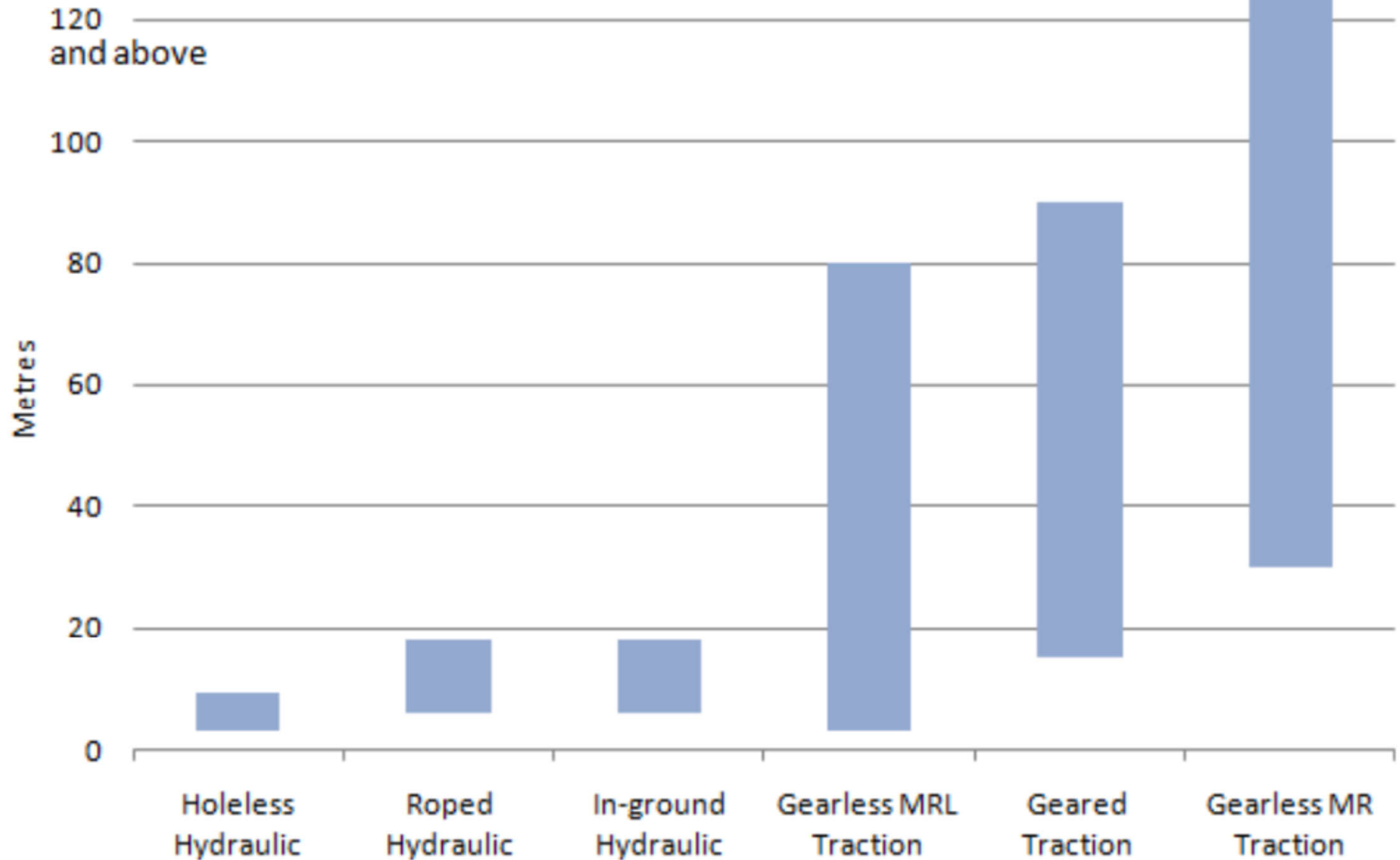

Note: MRL – Machine Roomless; MR – with Machine Room

(Source: ISR-University of Coimbra, 2010. E4 Energy-Efficient Elevators and Escalators, brochure prepared for the Intelligent Energy of European Commission, University of Coimbra, Portugal. https://ec.europa.eu/energy/intelligent/projects/sites/iee-projects/files/projects/documents/e4_publishable_report_en.pdf)

Planning & Design Factors



- Facilities for disabled persons -- “Barrier-free” access for buildings*, such as
 - Steps & stairs – colour contrast at interface
 - Ramps – max. gradient & minimum width
 - Handrails – suitable dimensions
 - Lifts – manoeuvring space
 - Lifting devices for wheelchair (e.g. at MTR)
- Using lifts for general evacuation

(*See also: BD, 2008. *Design Manual: Barrier Free Access 2008*, Buildings Department (BD), Hong Kong.

https://www.bd.gov.hk/doc/en/resources/codes-and-references/code-and-design-manuals/BFA2008_e.pdf)

Lift-assisted evacuation (for a very deep-sited MTR station in Hong Kong)

Lift shafts 70 m & 100 m deep

Lift speed = 4 to 5 m/s; lift capacity = 24-28 persons

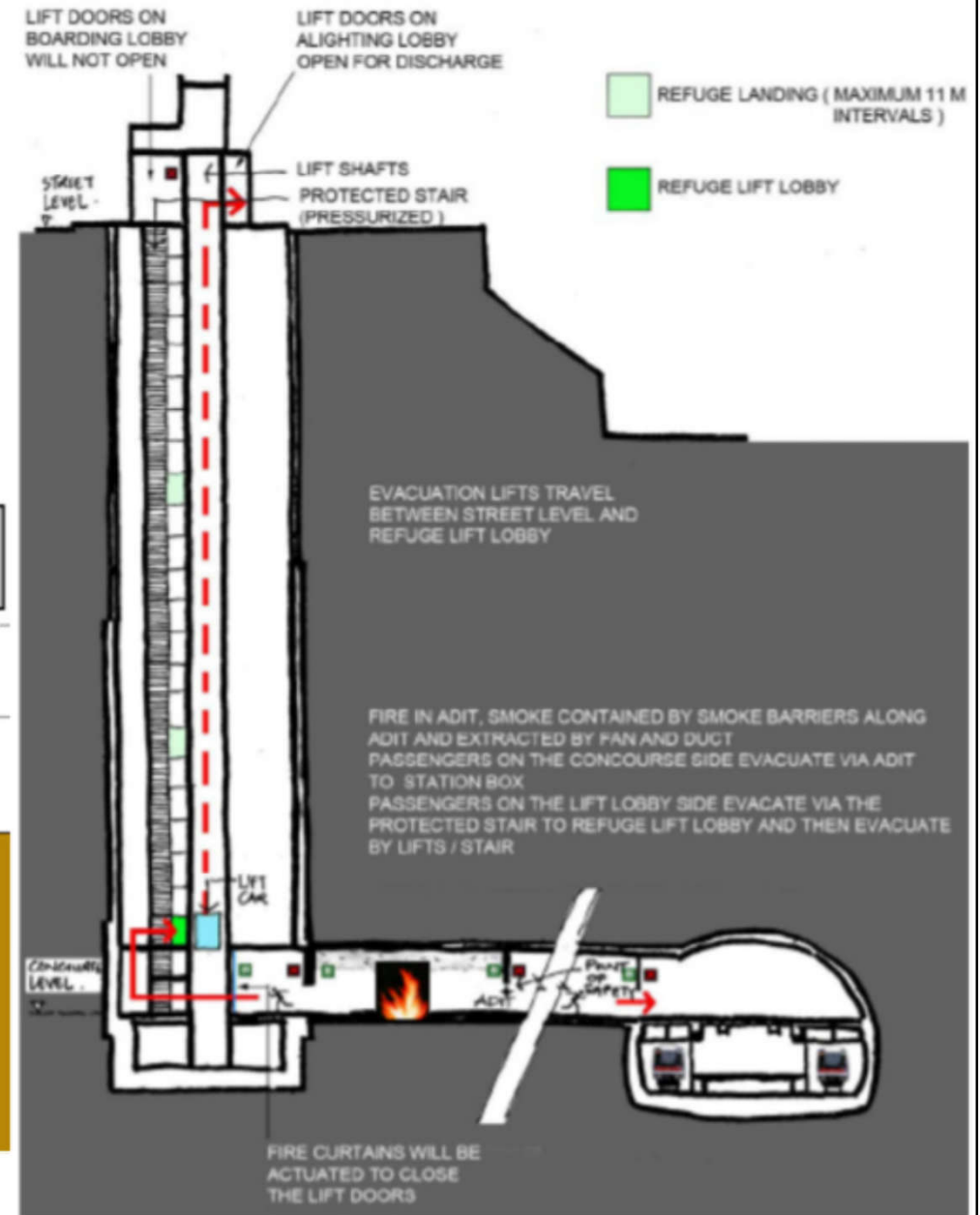
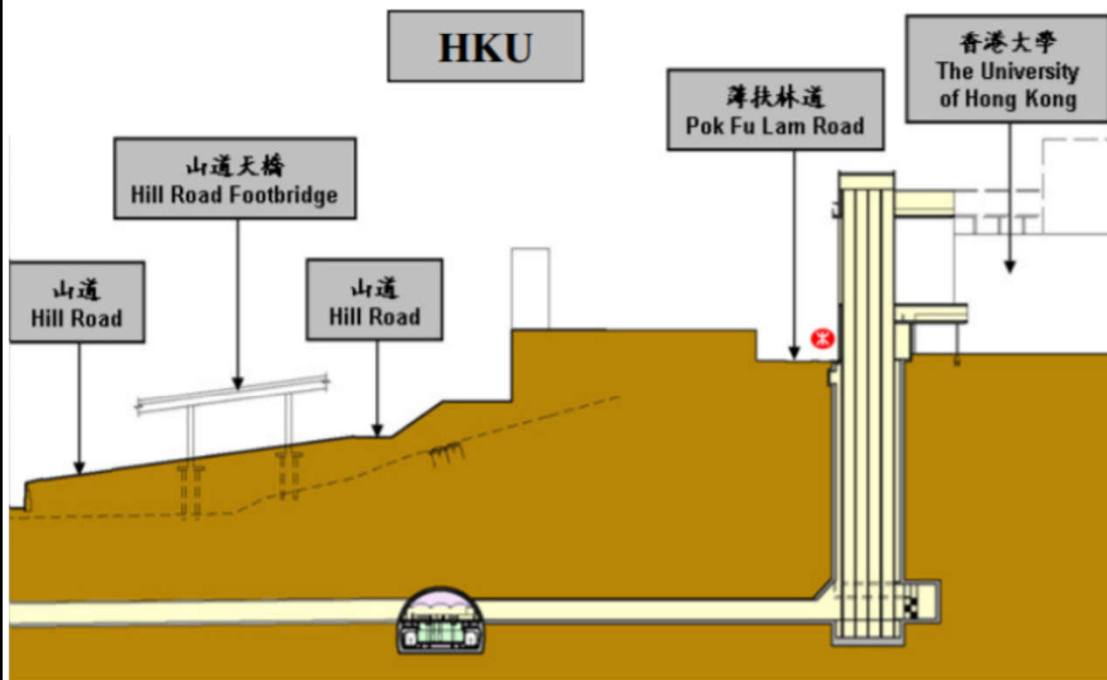
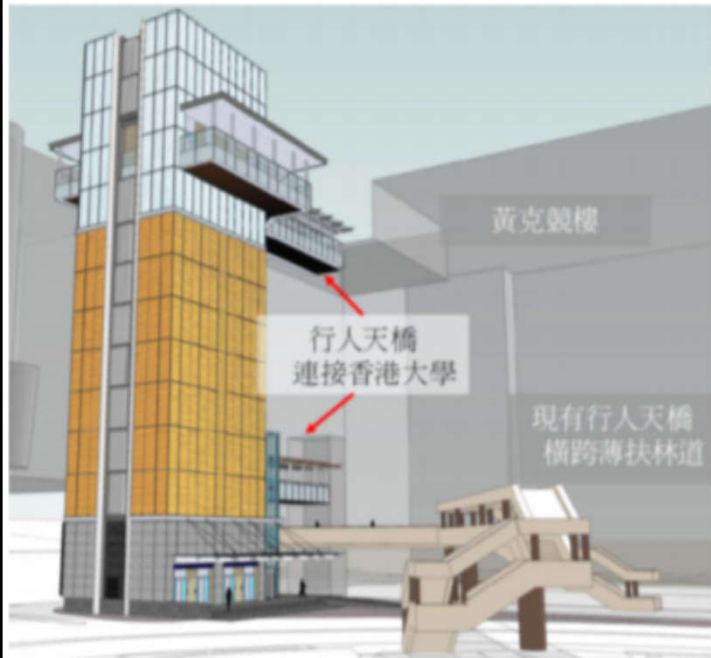

(Source: MTRC)

System Types



- Passenger lifts
 - Different requirements in various building types
 - Like commercial, hotels, hospitals, residential
 - Grouping of passenger lifts
 - Position & layout (for effective circulation & convenience)
 - Machine room/space
 - Hydraulic lifts: ideally at the lowest level
 - Electric traction lifts: directly above the lift well
 - Machine room-less lifts

Passenger lifts



System Types



- Observation lifts
 - Glazed or partially glazed lift car within a glazed or open-sided lift well
 - Also called wallclimber, scenic, glass, panoramic or bubble lifts
 - Within an atrium or external to the building
 - Design considerations
 - Visual impact (attracting sightseers)
 - Lift speed & handling capacity
 - Space requirements & maintenance



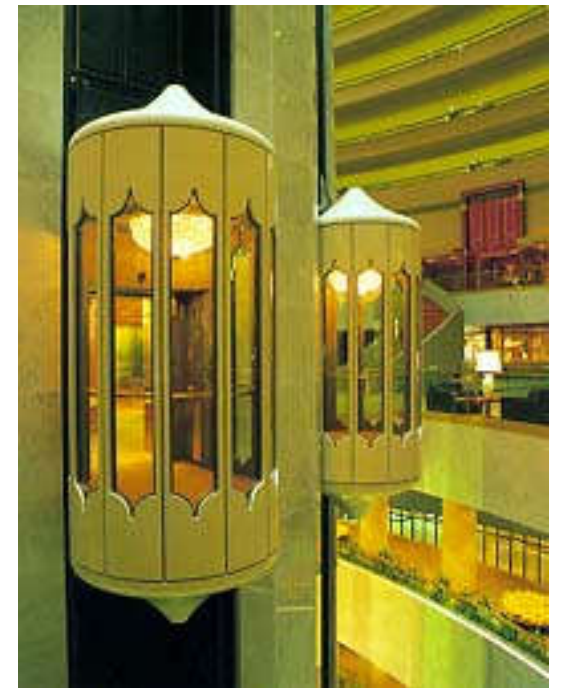
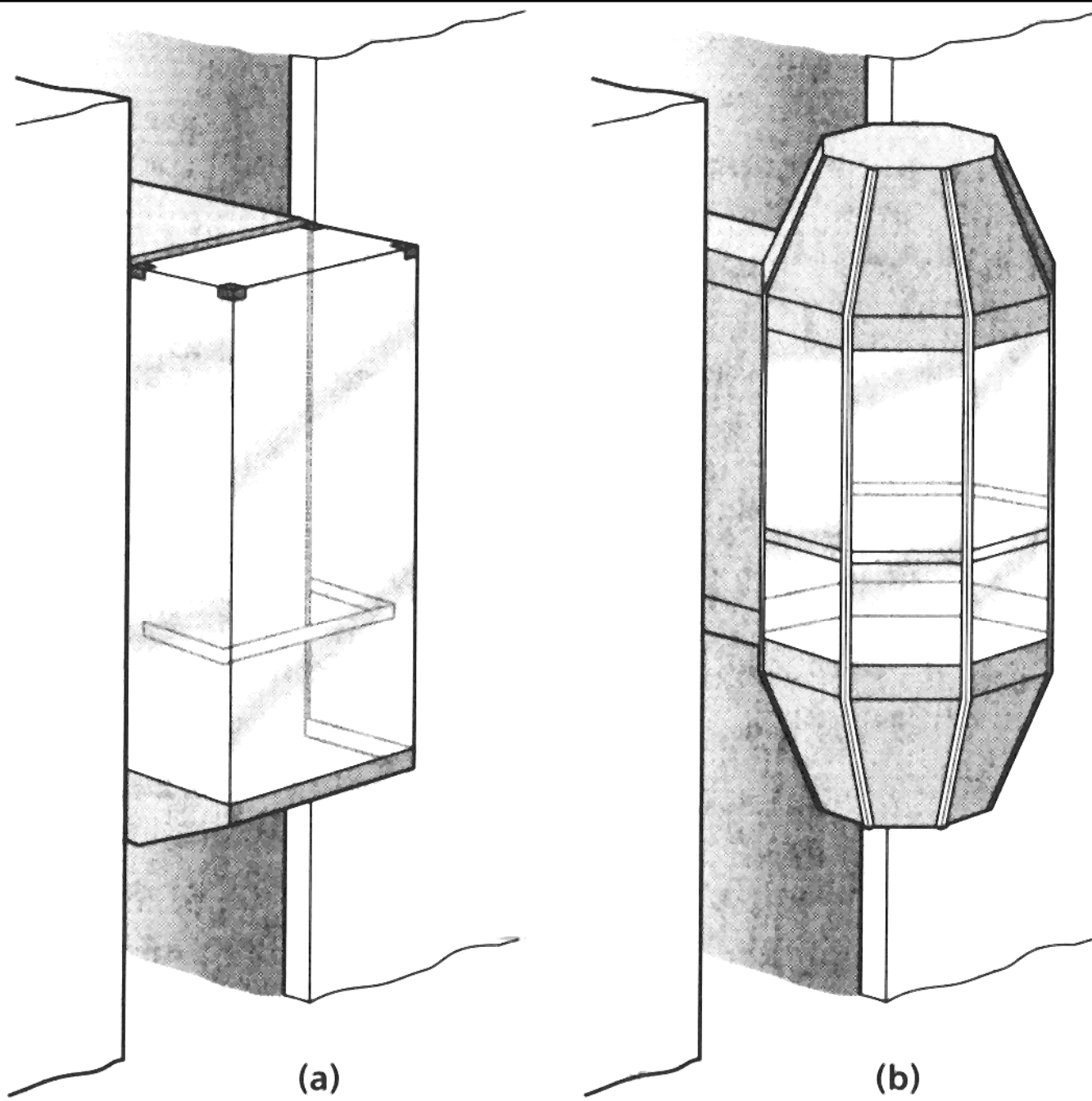

Figure 5.1 Typical observation lift cars; (a) rectangular without mullions, (b) octagonal with mullions

[Source: CIBSE Guide D]



System Types

- Lifts for the aged & disabled
 - Provision for wheelchair
- Good lifts & service lifts
 - Car sizes, payloads, well dimensions
- Dumbwaiter (e.g. in restaurants)
- Stair lifts
- Inclined lifts
- Scissor lifts



Inclined lift

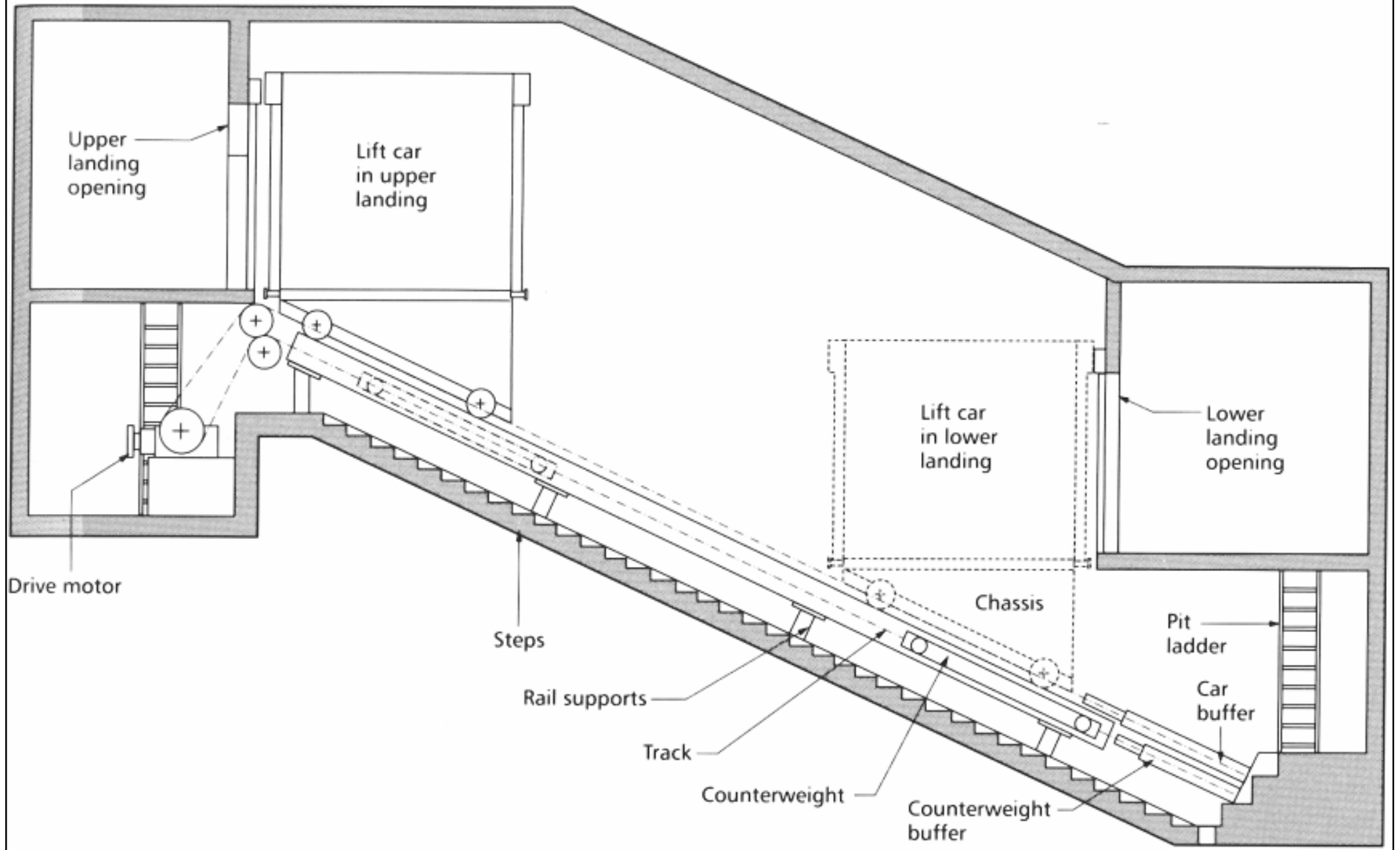

[Source: CIBSE Guide D]

Scissor lifts

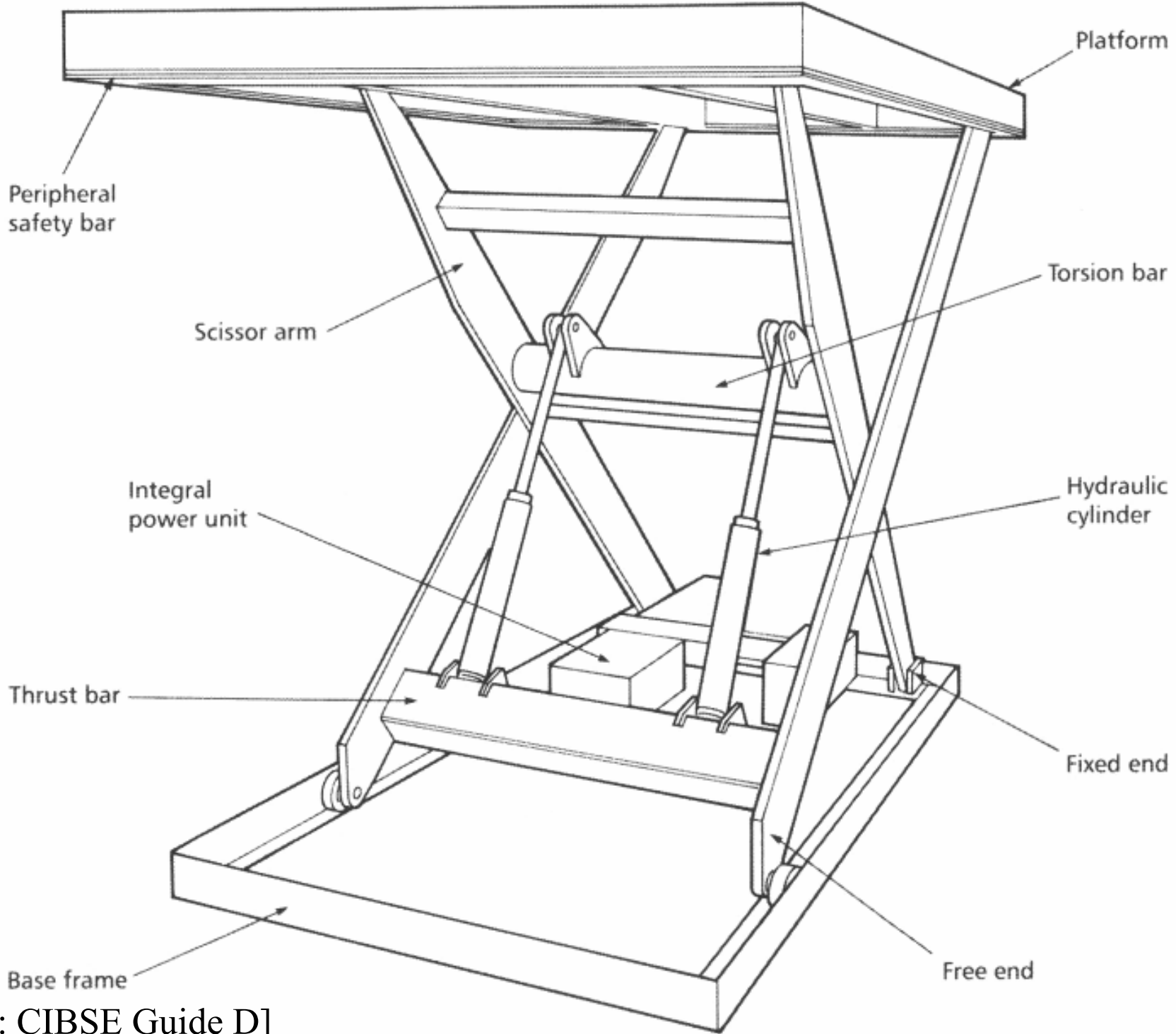

[Source: CIBSE Guide D]

Car parking lift system

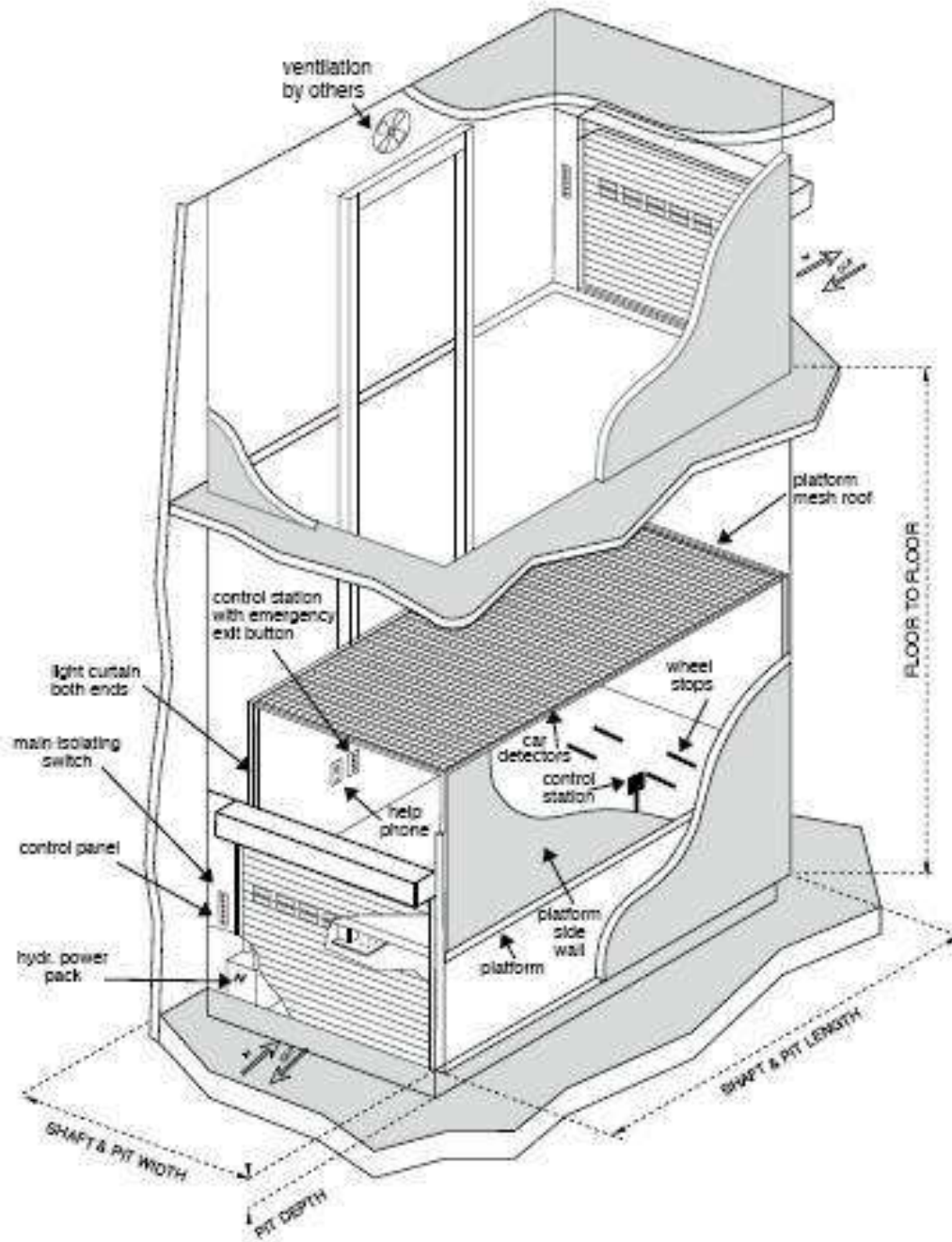

System Types



- Passenger conveyors
 - Other names: travelators, autowalks, moving walkway, moving pavement
 - Practical limit about 300 m distance
 - Useful in large airport terminals
 - Typical design factors:
 - May be inclined up to about 15°
 - Speed between 0.6 to 1.3 m/s (combined with walking, the overall pace is 2.5 m/s)
 - Materials must be flexible or elastic (e.g. reinforced rubber or interlaced steel plates)



Moving walkway

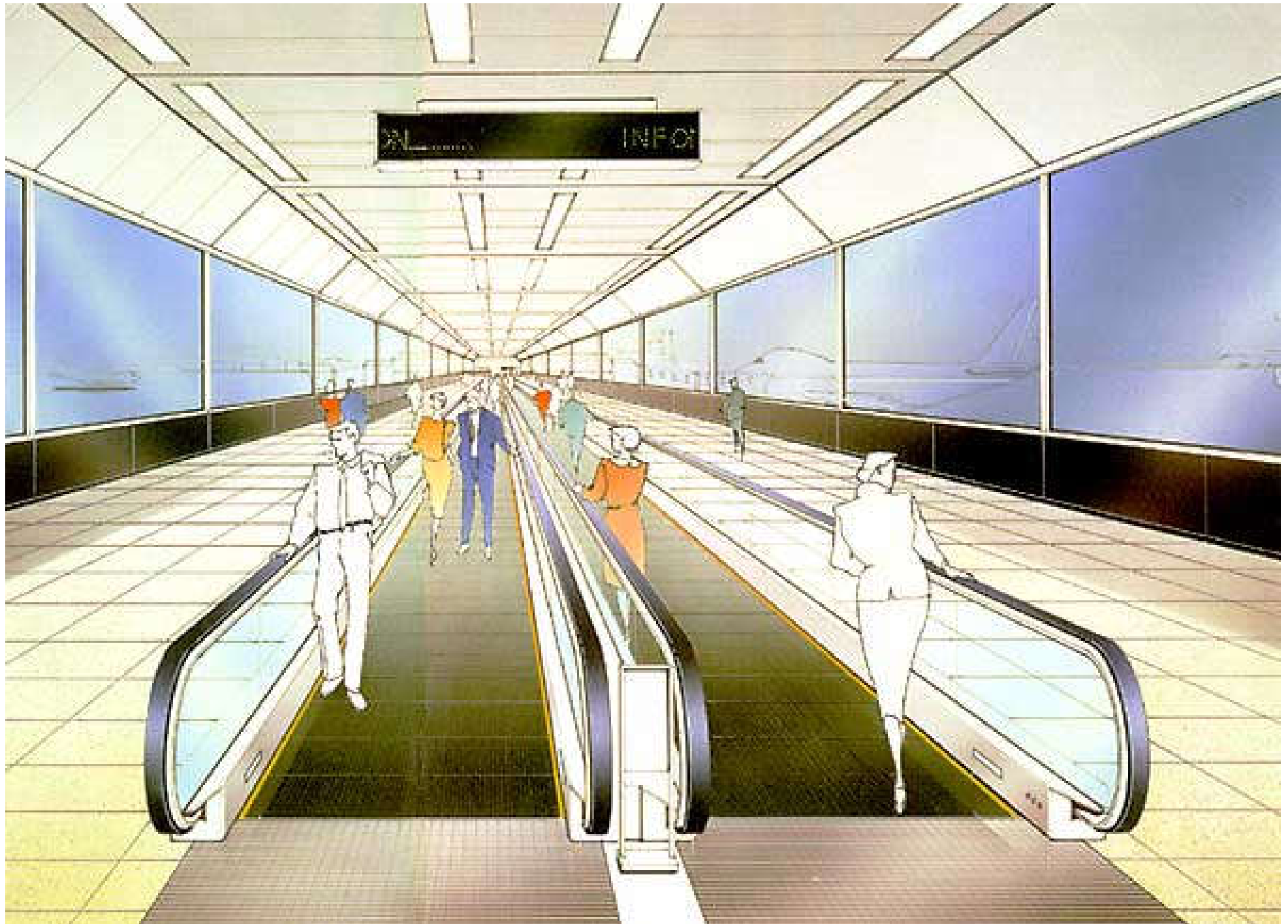

[Source: Mitsubishi Elevator and Escalator, <http://www.mitsubishi-elevator.com/>]

Inclined walkway



[Source: Mitsubishi Elevator and Escalator, <http://www.mitsubishi-elevator.com/>]

Regulations and Codes



- Relevant ordinances and regulations in HK
 - Lifts and Escalators (Safety) Ordinance (Chapter 327) (Repealed and replaced by Chapter 618)
 - **Lifts and Escalators Ordinance (Chapter 618)***
 - Lifts and Escalators (General) Regulation (Cap. 618A)
 - Lifts and Escalators (Fees) Regulation (Cap. 618B)
 - Buildings Ordinance (Chapter 123)
 - Building (Lifts) Regulations (Cap. 123E)
 - Building (Escalators) Regulations (Cap. 123D)

(*See also: https://www.emsd.gov.hk/en/lifts_and_escalators_safety/leo_intrdctn/)

Use permit for lift (left) and escalator (right)

機電工程署
EMSD

准用證(升降機)
Use Permit (Lift)

升降機及自動梯條例(第618章)
THE LIFTS AND ESCALATORS ORDINANCE (CHAPTER 618)

地點編號
Location ID. 1234567 - 001

升降機編號
Lift No. 1

地址
Address 香港安全街安全大廈
SAFETY BUILDING, SAFETY STREET, HONG KONG

屆滿日期
Date of Expiry 15 / 2 / 2014
日Day 月Month 年Year

發出日期
Date of Issue 30 / 1 / 2013
日Day 月Month 年Year

123456789



機電工程署
EMSD

准用證(自動梯)
Use Permit (Escalator)

升降機及自動梯條例(第618章)
THE LIFTS AND ESCALATORS ORDINANCE (CHAPTER 618)

地點編號
Location ID. 2345678 - 001

自動梯編號
Escalator No. 1

地址
Address 香港安全街安全商場
SAFETY SHOPPING ARCADE, SAFETY STREET,
HONG KONG

屆滿日期
Date of Expiry 15 / 2 / 2014
日Day 月Month 年Year

發出日期
Date of Issue 30 / 1 / 2013
日Day 月Month 年Year

123456789



Regulations and Codes



- Relevant ordinances and regulations (cont'd)
 - Factories and Industries Undertakings (Goods Lifts) Regulations (Chapter 59)
 - Requirements of Fireman's Lift (in Fire Services Department's Code of Practice)
 - Builders' Lifts and Tower Working Platforms (Safety) Ordinance (Chapter 470) (at construction sites)

Regulations and Codes



- Related standards and codes of practice
 - Code of Practice on the Design and Construction of Lifts and Escalators
 - Code of Practice for Lift Works and Escalator Works
 - Relevant British Standards (e.g. BS 5655(EN81) and BS5656(EN115))
 - Code of Practice for Safety at Work (Lift and Escalator)
 - Code of Practice on Building Works for Lifts & Escalators
 - Circular letters from EMSD related to lifts and escalators
 - Guidelines on safety of lift shaft works issued by Construction Industry Council

Regulations and Codes



- Relevant terms:
 - Responsible person
 - Who owns, manages or controls the lift/escalator
 - Registered persons
 - Registered escalator contractor, engineer or worker
 - Registered lift contractor, engineer or worker
 - Competent lift/escalator worker
 - Qualified person
 - Registered engineer (RE), registered worker (RW), or competent worker (CW) of the registered contractor (RC) undertaking the works

Works undertaken by an Registered Contractor (RC) and an Registered Engineer (RE)

| Party undertaking lift works or escalator works | Registered Contractor (RC) | Registered Engineer (RE) |
|---|----------------------------|--------------------------|
| Type of lift works or escalator works | Installation | |
| | Commissioning | Commissioning |
| | Examination | Examination* |
| | Maintenance | |
| | Repair | |
| | Alteration | |
| | Demolition | |

* REs are authorized under the Ordinance to issue a certificate following thorough examination of a lift or an escalator to certify that the lift or the escalator is in safe working order or to report that the installation is **not** in safe working order.

Regulations and Codes



- Registration system
 - Registered Lift/Escalator Contractor (RLC/REC)
 - Registered Lift/Escalator Engineer (RLE/REE)
 - Registered Lift/Escalator Worker (RLW/REW) (*new*)
- Requirements of RLE and REE
 - Relevant qualifications, training & experience
 - Written examination + interview (conducted by EMSD)
 - Renew their registration every 5 years
- Further info:
https://www.emsd.gov.hk/en/lifts_and_escalators_safety/registrations/

Lift Traffic Analysis

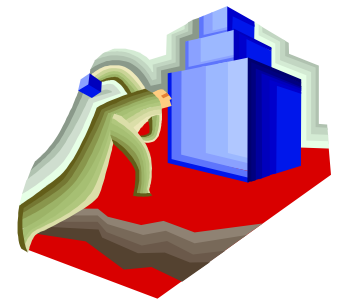

- Assessment of demand
 - Lift traffic patterns (e.g. in an office building)
 - Morning UP peak
 - Evening DOWN peak
 - Mid-day two-way traffic (lunch periods)
 - Interfloor traffic
 - Other considerations, e.g. ‘Flexitime’ attendance
 - Estimation of population (occupant density)
 - Estimation of arrival rate

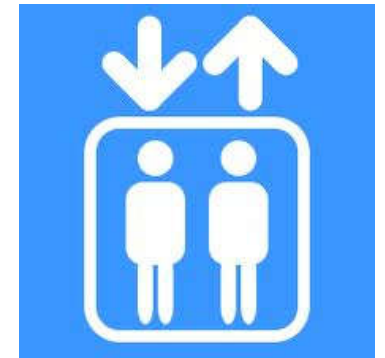

Four distinct (classical) traffic patterns in an office building

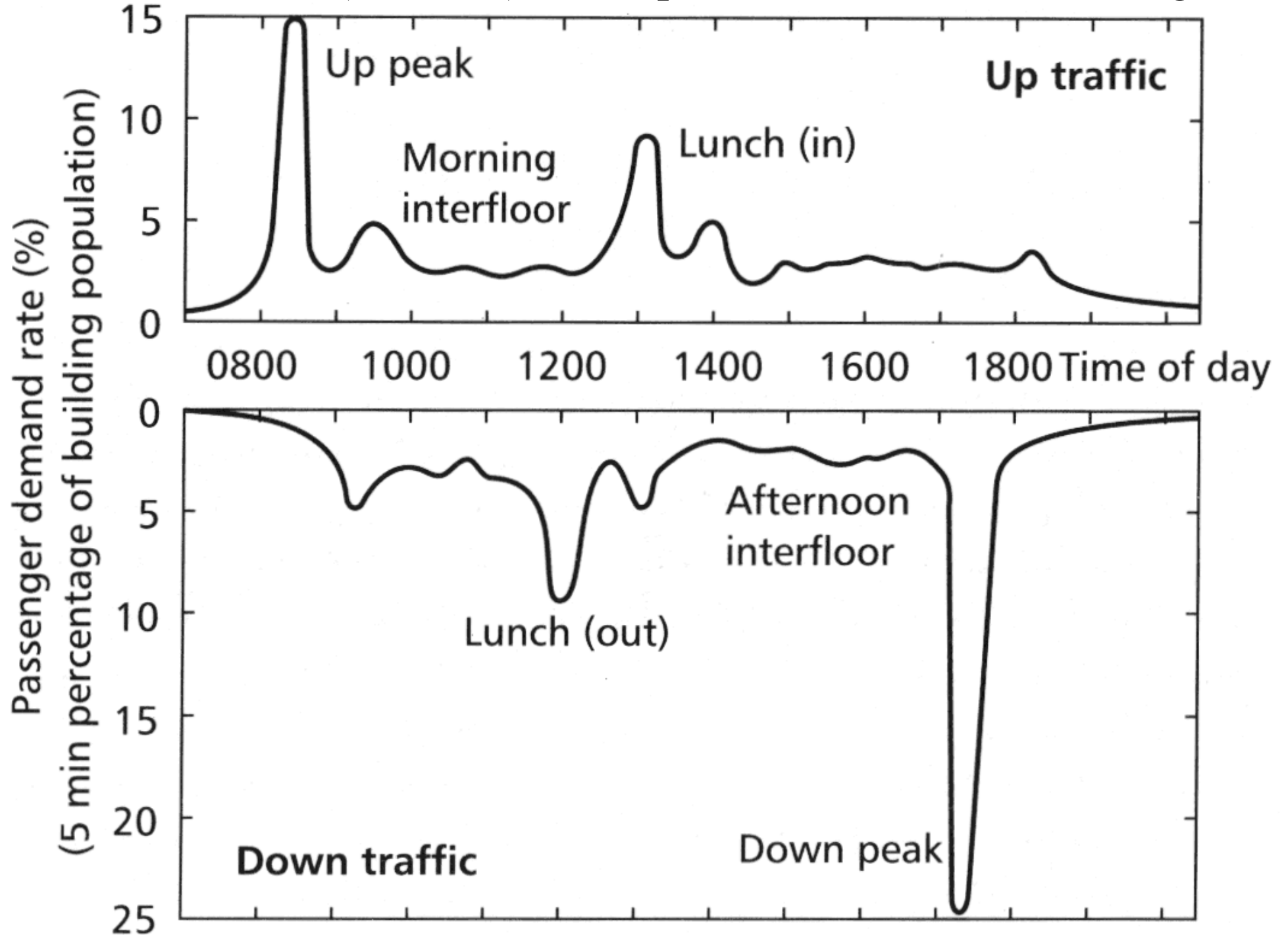

Up peak traffic profile

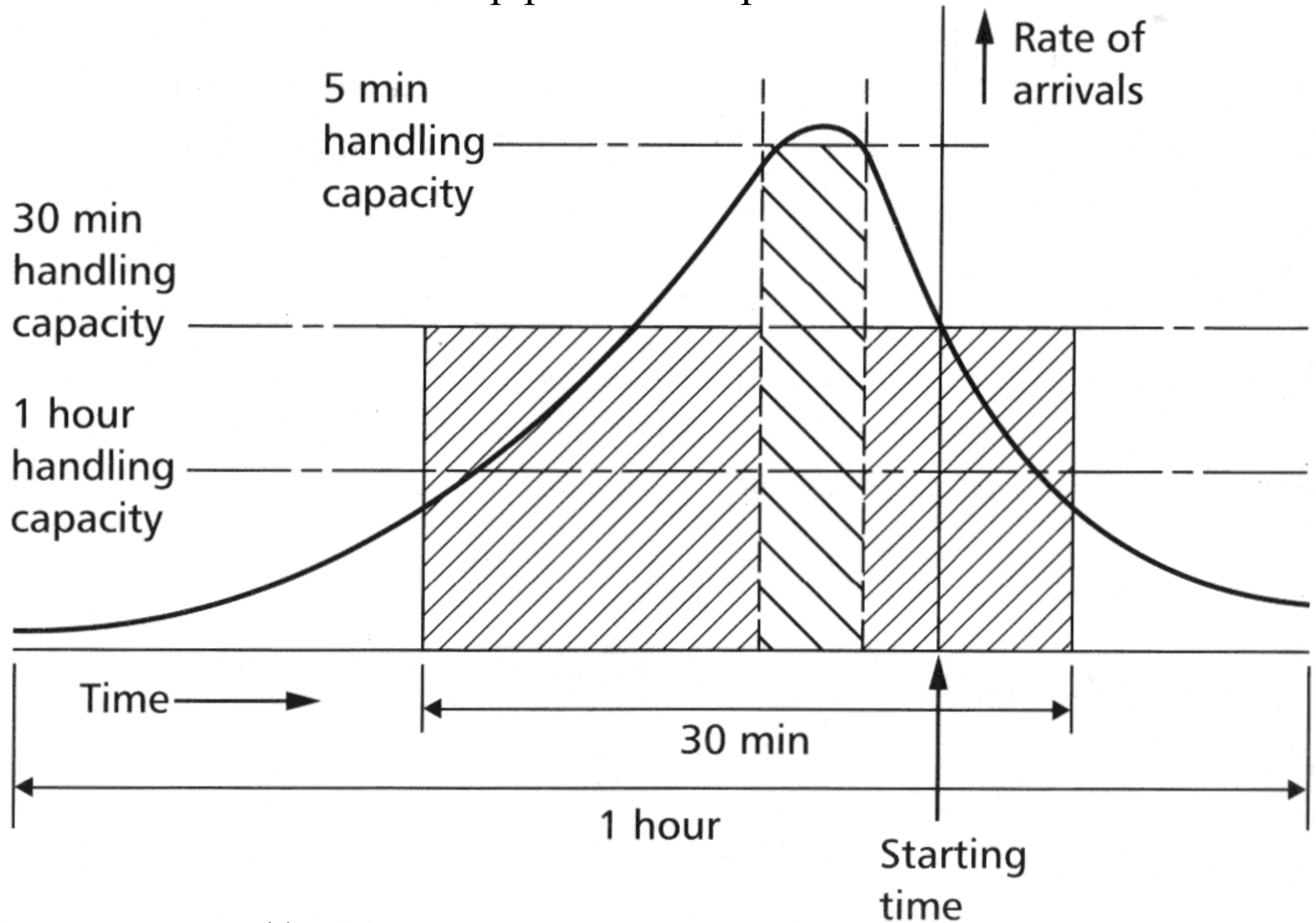

Down peak traffic profile

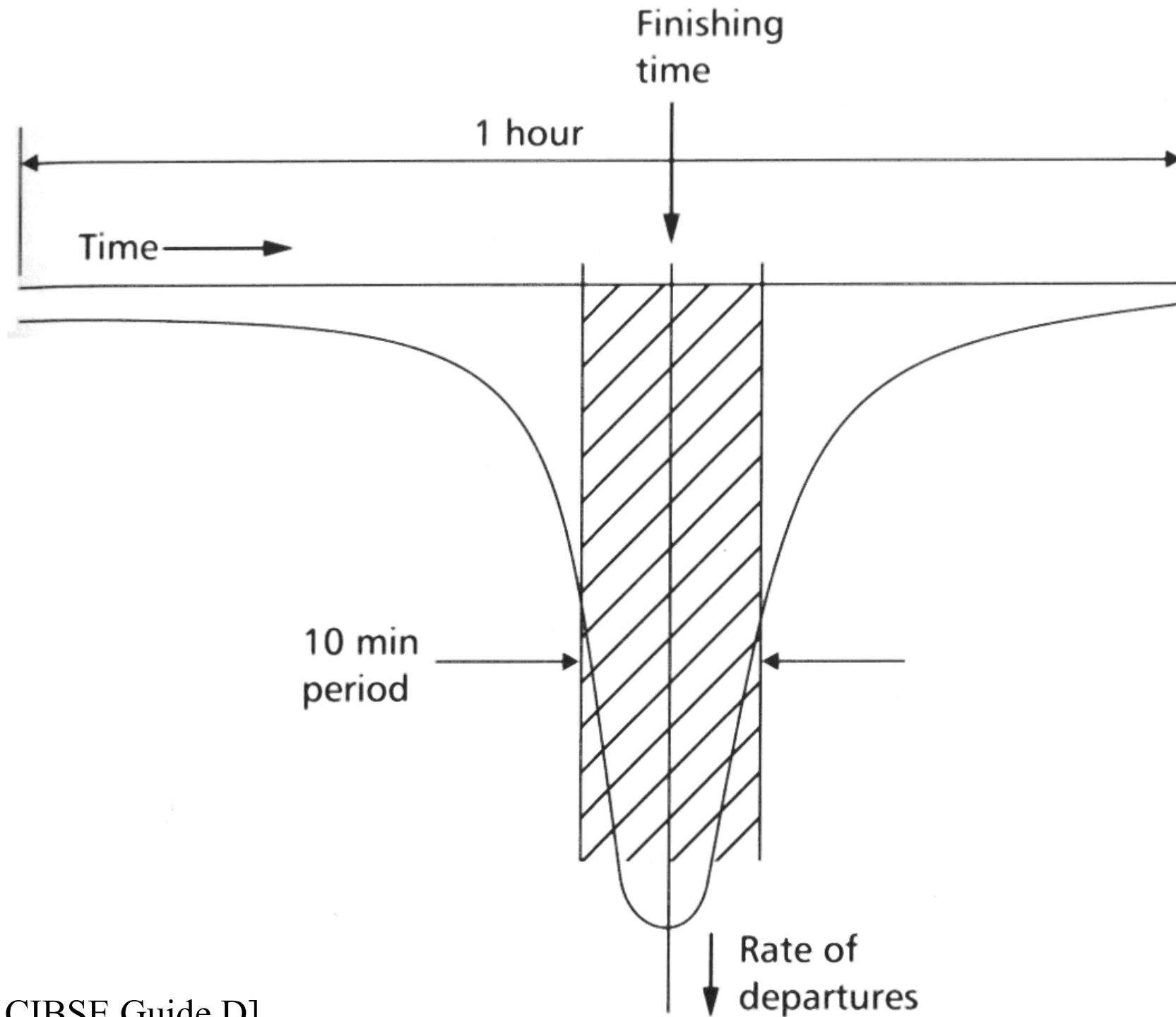

Lift Traffic Analysis

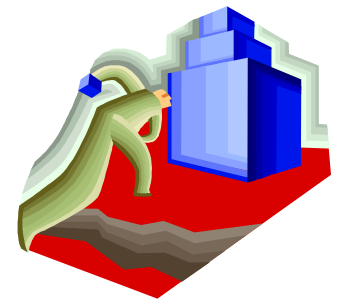

- Factors to be considered:
 - Population or no. of people who require lift service (based on building type)
 - Handling capacity or maximum flow rate required by the people (total no. of passengers handled during the peak period of the day)
 - Interval or quality of service required (passenger waiting time of the various floors)

Estimation of population

| Building type | Estimated population** |
|----------------------------|---------------------------------------|
| Hotel | 1.5-1.9 persons/room |
| Flats | 1.5-1.9 persons/bedroom |
| Hospital | 3.0 persons/bedspace* |
| School | 0.8-1.2 m ² net area/pupil |
| Office (multiple tenancy): | |
| - Regular | 10-12 m ² net area/person |
| - Prestige | 15-18 m ² net area/person |
| Office (single tenancy): | |
| - Regular | 8-10 m ² net area/person |
| - Prestige | 12-20 m ² net area/person |

* excluding patient

** Buildings in Hong Kong often have higher population density.
May need to increase the number of people by 10-20%.

Percentage arrival rates and up-peak intervals

| Building type | Arrival rate (%) | Interval (sec) |
|----------------------------|-------------------------|-----------------------|
| Hotel | 10-15 | 30-50 |
| Flats | 5-7 | 40-90 |
| Hospital | 8-10 | 30-50 |
| School | 15-25 | 30-50 |
| Office (multiple tenancy): | | |
| - Regular | 11-15 | 25-30 |
| - Prestige | 15-17 | 20-25 |
| Office (single tenancy): | | |
| - Regular | 15 | 25-30 |
| - Prestige | 15-17 | 20-25 |

Lift Traffic Analysis



- Estimation of quality of service
 - Actual average passenger waiting time (AWT)
 - Time between the instant of passenger arrival until the instant of the actual arrival of the lift
 - Shorter the waiting time, better the service
 - But cannot be measured easily
 - Interval of car arrivals at the main terminal
 - Often taken to estimate the probable quality of service
 - A part of the evaluation of handling capacity
 - $AWT \approx 85\%$ of the interval (assumed 80% car loading)

Probable quality of service in office buildings

| Interval (sec) | Quality of service |
|-----------------------|---------------------------|
| ≤ 20 | Excellent |
| 25 | Very good |
| 30 | Good |
| 40 | Poor |
| ≥ 50 | Unsatisfactory |

Lift Traffic Analysis

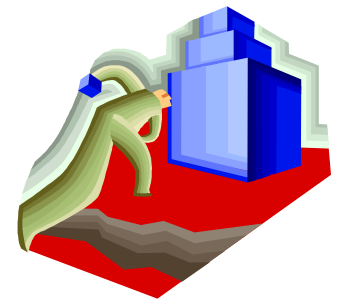

- Two methods of lift traffic analysis:
 - (1) Based on **classical formulae** & results
 - The worst 5-min period during morning up peak only
 - (2) Based on a **discrete digital simulation** of the building, its lifts and the passenger dynamics
 - Such as for down peak, two-way & interfloor traffic
- Need to work at early design stage with architect or planner, and the client to establish the lift system & its design criteria

Lift Traffic Analysis



- Calculate up peak performance
 - Determine round trip time (RTT)
 - Time for a single lift to make a round trip
 - Select number of lifts (L)
 - Determine up peak interval (UPPINT)
 - Such as, ≤ 30 sec (good)
 - Determine up peak handling capacity (UPPHC)
 - During the worst 5-min (300 sec) of up peak

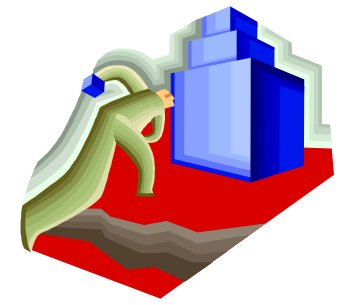

Lift Traffic Analysis

- $RTT = 2 H t_v + (S + 1) t_s + 2 P t_p$
 - H = average highest call reversal floor
 - t_v = single floor transit time (s)
 - S = average no. of stops
 - t_s = time consumed when stopping (s)
 - P = average no. of passengers carried
 - t_p = passenger transfer time (s)
- $UPPINT = RTT / L$
- $UPPHC = (300 \times L \times P) / RTT$

The elements of a round trip

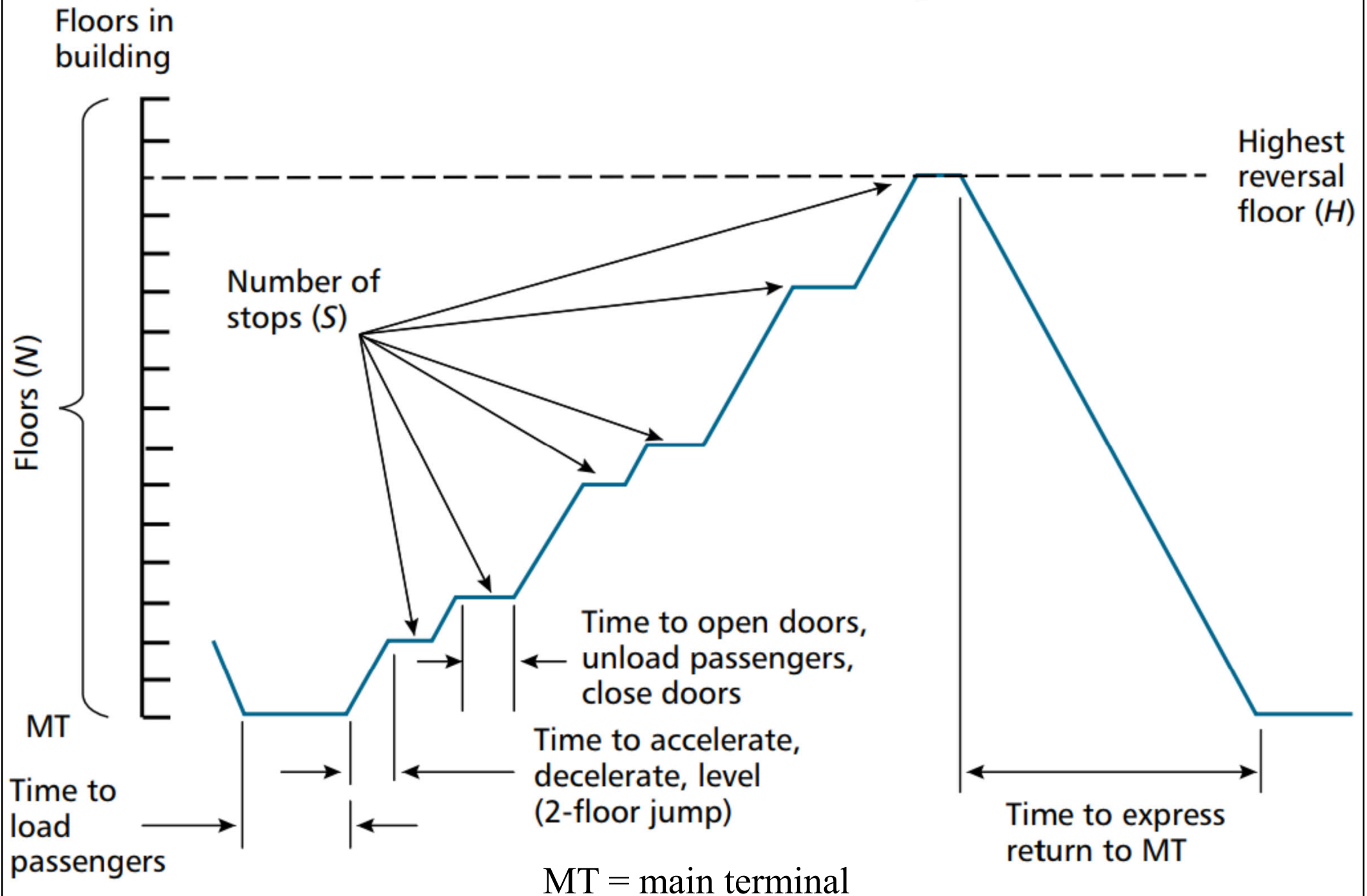

[Source: CIBSE Guide D]

Lift Traffic Analysis



- Parameters in RTT equation
 - Average no. of passengers (P)
 - $P = 0.8 \times$ rate capacity of lift car
 - Average highest call reversal floor (H)

$$H = N - \sum_{i=1}^{N-1} \left(\frac{i}{N} \right)^P$$

- Average no. of stops (S)

$$S = N \times \left(1 - \left(1 - \frac{1}{N} \right)^P \right)$$

Lift Traffic Analysis

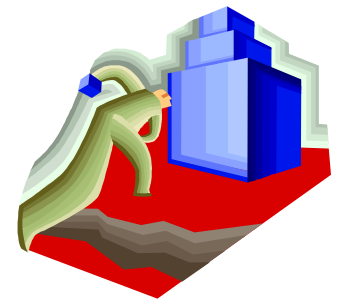

- Parameters in RTT equation (cont'd)

- Single floor transit time, $t_v = d_f / v$

- d_f = average interfloor distance (m)

- v = contract (rated) speed (m/s)

- For a lift serving an upper zone, an extra time to make the jump to/from the express zone to the main terminal must be added:

$$\text{RTT} = 2 H t_v + (S + 1) t_s + 2 P t_p + [2 H_e t_v]$$

- H_e = number of average height floors passed through to reach the first served floor of the express zone

Lift Traffic Analysis



- Parameters in RTT equation (cont'd)

- Time consumed when stopping

$$t_s = T - t_v = t_f(1) + t_c + t_o - t_v$$

- T = floor-to-floor cycle time (s)
- $t_f(1)$ = single floor flight time (s)
- t_c = door closing time (s)
- t_o = door opening time (s)
- Floor cycle time (T) has the most effect on RTT
 - Can be used to judge the quality of service
 - For a good system, $T = 9$ to 10 sec

Lift Traffic Analysis

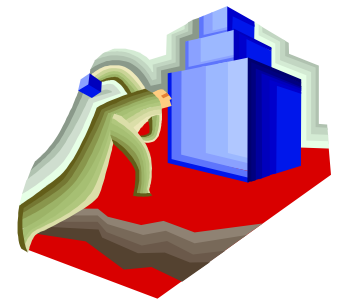

- Parameters in RTT equation (cont'd)
 - Passenger transfer time (t_p), vague to define. It depends on:
 - Shape of lift car
 - Size and type of car entrance
 - Environment (commercial, institutional, residential)
 - Type of passenger (age, gender, purpose, etc)

Lift Traffic Analysis

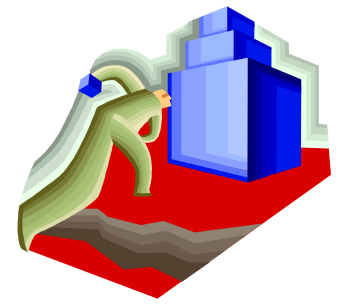

- Basic assumptions of RTT equation
 - Average no. of passengers
 - Passengers arrive uniformly in time
 - All floors equally populated
 - All cars load to 80%
 - Rated speed reached in a single floor jump and interfloor height are equal
 - Other operating time (like dwell time) ignored
 - Traffic controller is 'ideal'

Lift Traffic Analysis



- Average passenger waiting time (AWT)
 - Average time an individual passenger waits at a floor before being able to board a lift
 - Not dependent solely on UPPINT
 - Also affected by the average car load and the arrival probability distribution function
 - Some design criteria for different traffic patterns have been derived empirically based on the simulation method (see *CIBSE Guide D*)

Lift cycle time definitions

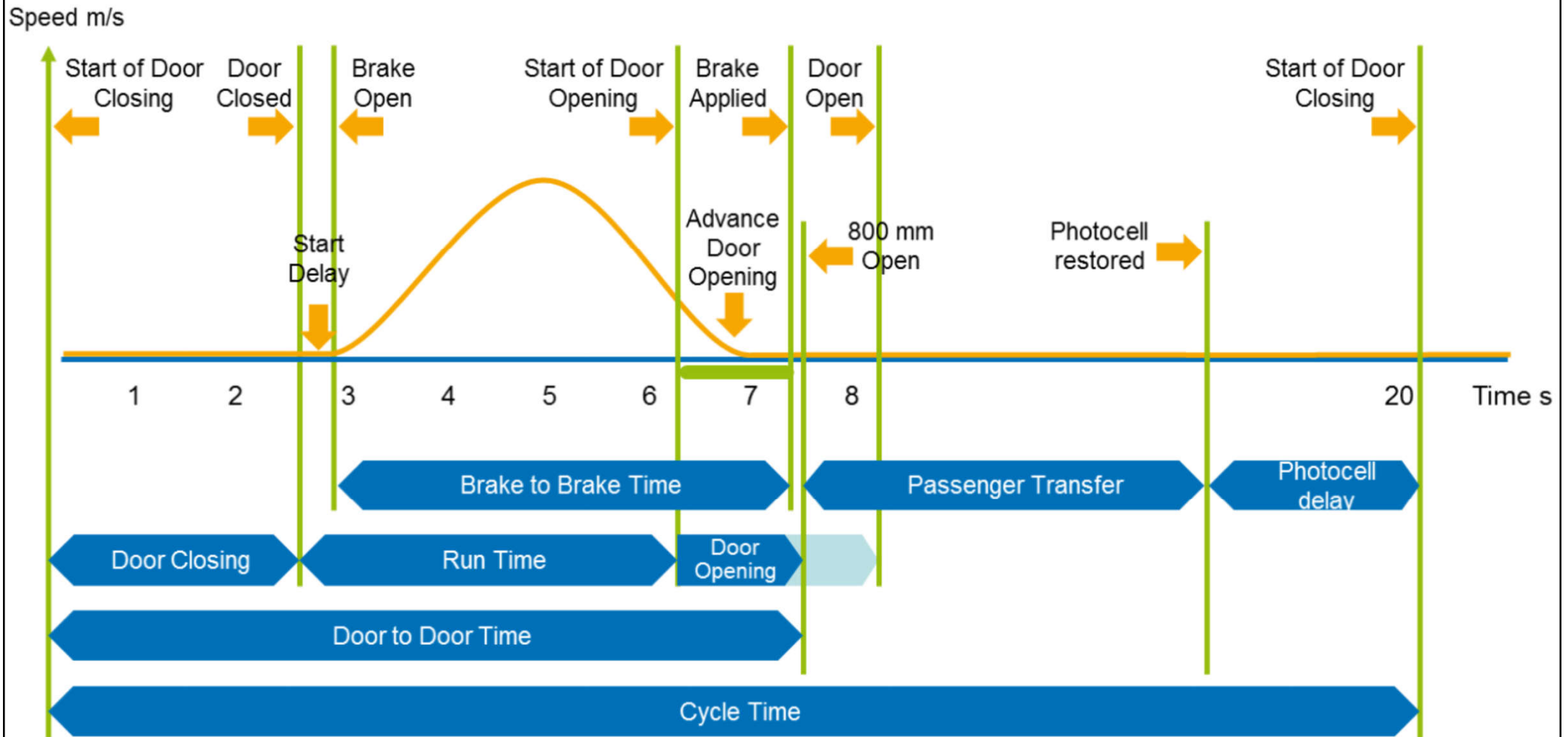

Lift Traffic Analysis



- Computer software (lift traffic analysis)
 - Lift traffic design spreadsheet (by Gina Barney)
<http://tandfmedia.s3.amazonaws.com/products/9781138852327/GinaBarneyLiftTools-ETH2.xlsx>
 - [SIMPLE](#) (suite of iterative balance method and other programs for lift and elevator design)
 - <http://ibse.hk/IBTM6010H/barney.zip>
 - Download, unzip & run the software by "gosimple.bat"
 - [ELEVATE](#) (elevator traffic analysis and simulation software) <http://www.elevate.peters-research.com/>
 - ELEVATE 7.0 demo version <http://www.elevate.peters-research.com/pricelist.htm>

SIMPLE software

Welcome to Dr Gina Barney's lift programs.

All enquiries to PO Box 7, Sedbergh, Cumbria, LA10 5GE, UK.

Tel: +44(0)15396 20790 Fax: +44(0)15396 20578

Email: none WEB: www.liftconsulting.org

Copyright Gina Barney: 1991-2002

caveat emptor

- 1 Iterative balance method
- 2 Lift traffic design
- 3 Lift traffic design with basements
- 4 Double deck design
- 5 Down peak estimate
- 6 Lift dynamics
- 0 Exit

Your choice ?

ELEVATE software

The screenshot displays the ELEVATE software interface. At the top, there is a menu bar with options: File, Edit, Analysis, Tools, View, Window, and Help. Below the menu is a toolbar with various icons for file operations, simulation control (play, pause, stop), and zooming. The main area contains a data table with the following structure:

| Time (hrs:min:sec) | 11:17:49 | Direction | Λ | Λ | Λ | V |
|--------------------|----------------|---------------|-------|-------|-------|-------|
| AWT (s) | 9.3 | Position (m) | 13.84 | 0.97 | 15.20 | 1.90 |
| ATT (s) | 30.0 | Speed (m/s) | 1.45 | 1.24 | 0.00 | 1.74 |
| | | Load (kg) | 600 | 225 | 150 | 225 |
| Floor Name | People Waiting | Landing Calls | Car 1 | Car 2 | Car 3 | Car 4 |
| Level 8 | 0 | | ■ | ■ | | |
| Level 7 | 0 | | ■ | | ■ | |
| Level 6 | 1 | ▲ | ■ | ■ | ■ | |
| Level 5 | 1 | ▼ | ■ | ■ | ■ | |
| Level 4 | 0 | | | | | |
| Level 3 | 0 | | | | | |
| Level 2 | 0 | | | ■ | | ■ |
| Level 1 | 0 | | | ■ | | ■ |

The table uses blue squares to represent elevator cars and red and green triangles to represent landing calls. A 'NUM' button is visible in the bottom right corner of the interface.

Advanced Traffic Planning

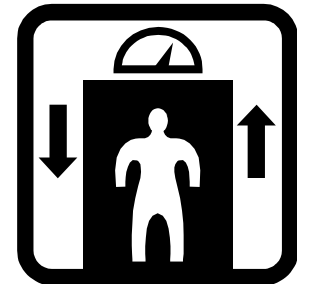

- Basic issues
 - The “[art](#)” of lift traffic planning
 - Efficient planning is based on the characteristics & population distribution of a building
 - Good traffic planning results in:
 - Correct number & type of transportation devices
 - Right size & speed for transportation devices
 - Control systems & other features that optimize & synchronize traffic flow
 - Optimum layout including positioning in the building & in relation to one another
 - Easy access to buildings and a smooth flow of people & goods

Advanced Traffic Planning

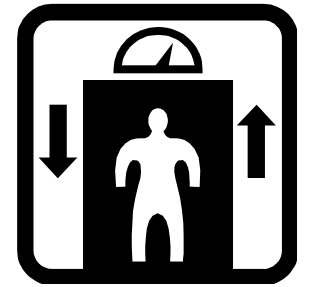

- Key considerations
 - Lifts and escalators should provide
 - Sufficient handling capacity for the building's traffic
 - Short waiting and journey times throughout the day
 - Optimum use of core building space
 - The main parameters are
 - Handling Capacity (HC) – the number of people the elevators can carry to upper floors within five minutes during the morning "up-peak"
 - Interval (I) – the average departure time for elevators from the main entrance during morning up peak

Advanced Traffic Planning

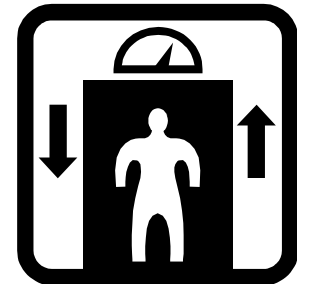

- Building categorization
 - The need for traffic planning varies according to the type & usage of the building
 - Typical categories:
 - Residential
 - Public service (e.g. subways, shopping centers, airports)
 - Hospital and multi-purpose buildings
 - Commercial mid-, high- and mega high rise -buildings (e.g. offices, hotels, cruise liners)

Advanced Traffic Planning

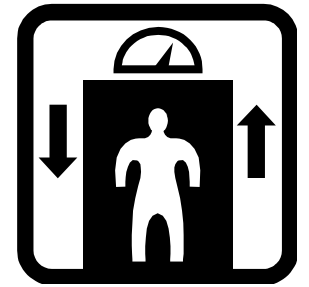

- Residential buildings
 - Traffic intensity is rather low
 - Waiting times even twice as long as those in commercial buildings may be acceptable
 - Can normally be selected by using local, international or comparable standards
- Public service (airports/subways, shopping centres)
 - Travelling height is typically no more than a few floors
 - Escalators can handle many times the traffic of lifts
 - Autowalks speed the people flow across long walking distances
 - Lifts are usually provided for handicapped access and the transport of goods or equipment

Performance criteria for passenger elevators

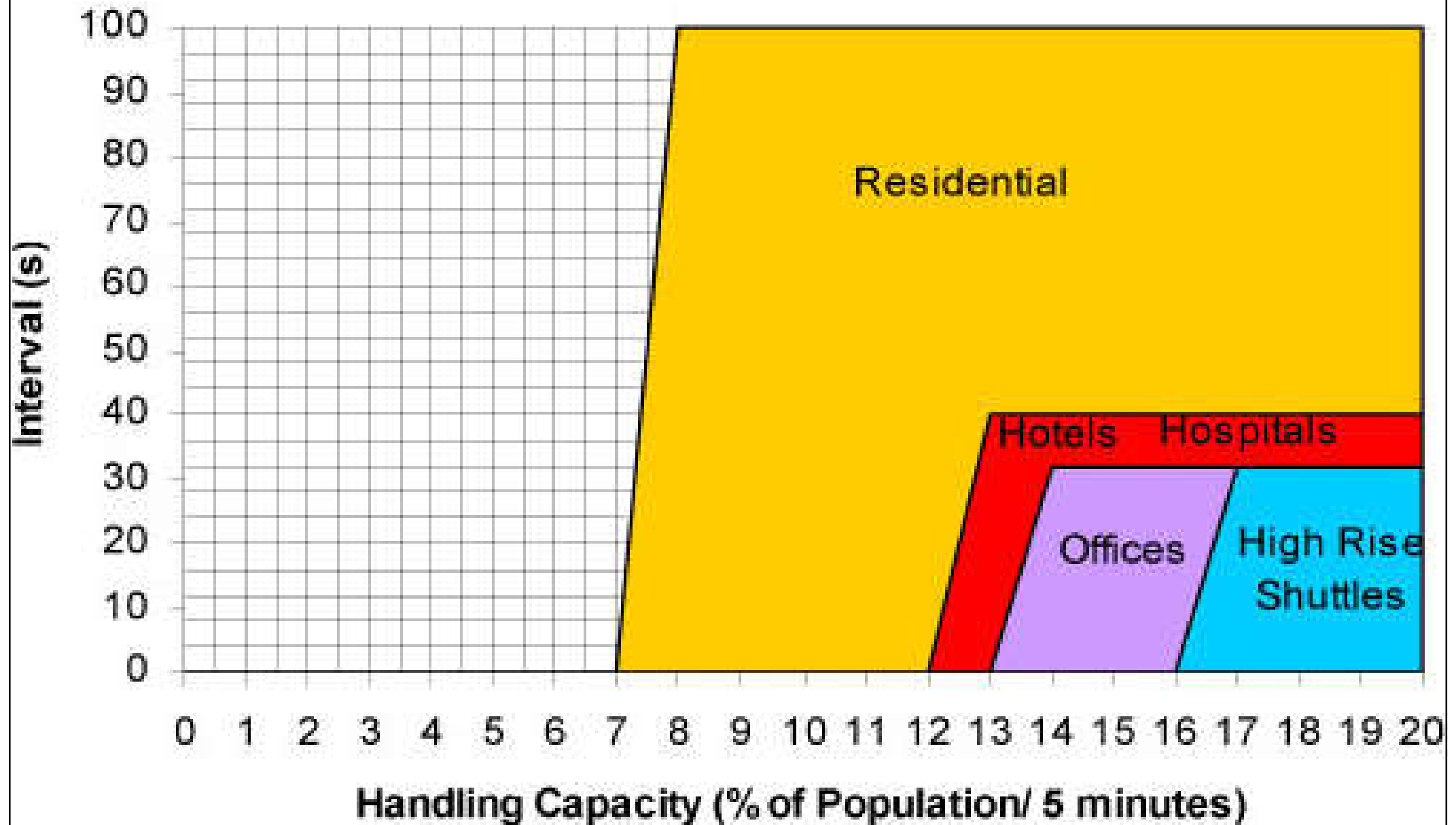

Residential buildings – passenger traffic flow

Double Triplex

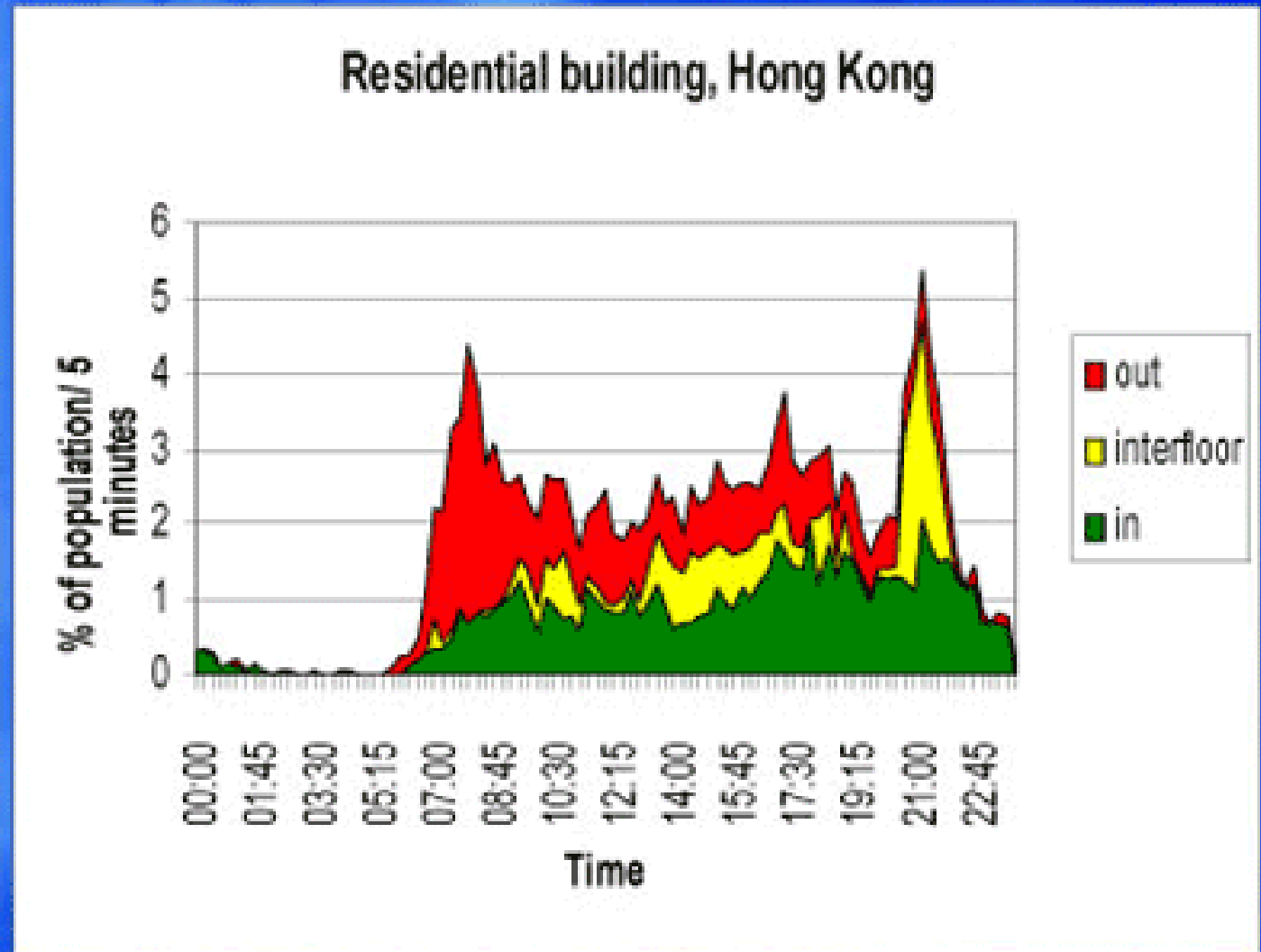
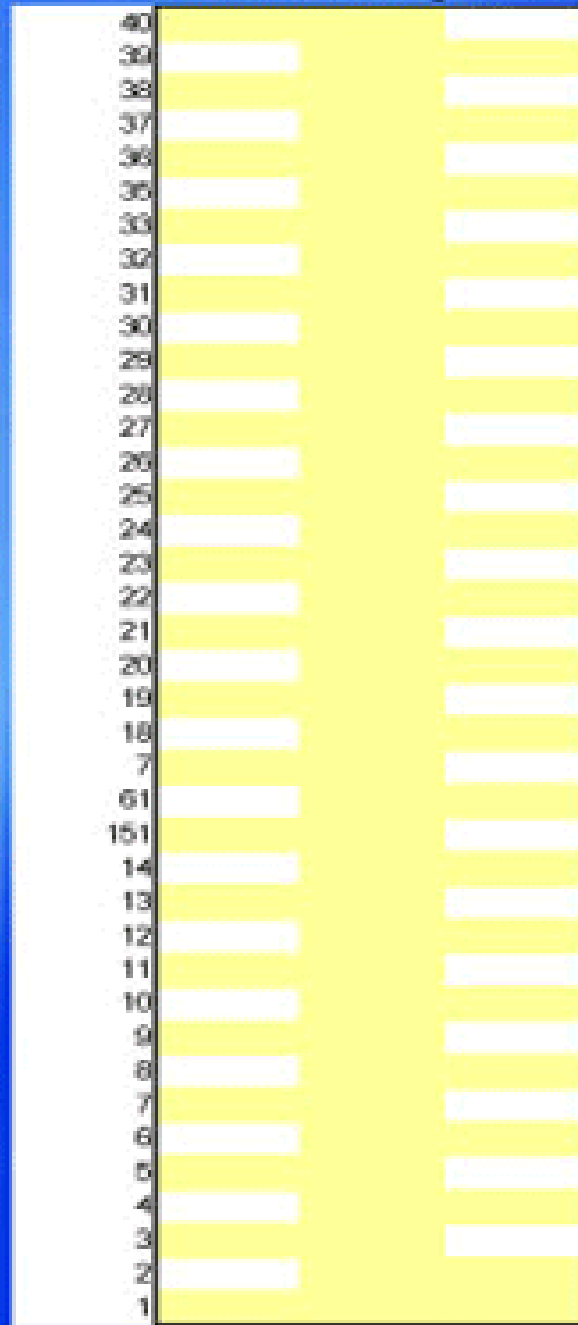

Advanced Traffic Planning

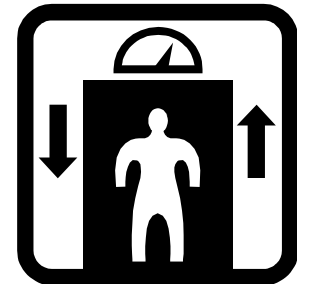

- Hospitals

- Need detailed planning to cover emergency, service, bed, patient, visitor and staff transportation
- Architecture and special needs e.g. the location of the operating theatre affect transportation arrangements

- Multi-purpose buildings

- Separate elevators for different purposes
- If the same lifts are to serve office and residential areas, they should be selected according to the highest estimated peak traffic demands

Advanced Traffic Planning

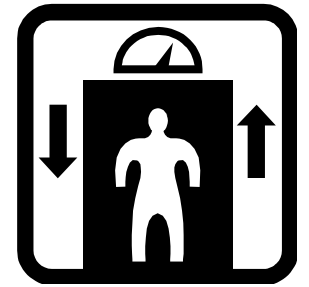

- Mid-rise commercial buildings
 - Hotels: the selection largely depends on the number of rooms and beds. Additional lifts are required for service purposes
 - Office buildings: three peak traffic hours generally occur: morning up peak, lunchtime mixed traffic and evening down peak
 - Up peak is normally used in lift planning
 - Lunch hour traffic is often heavier than the morning up peak

Passenger demand for office building with a restaurant at an upper level

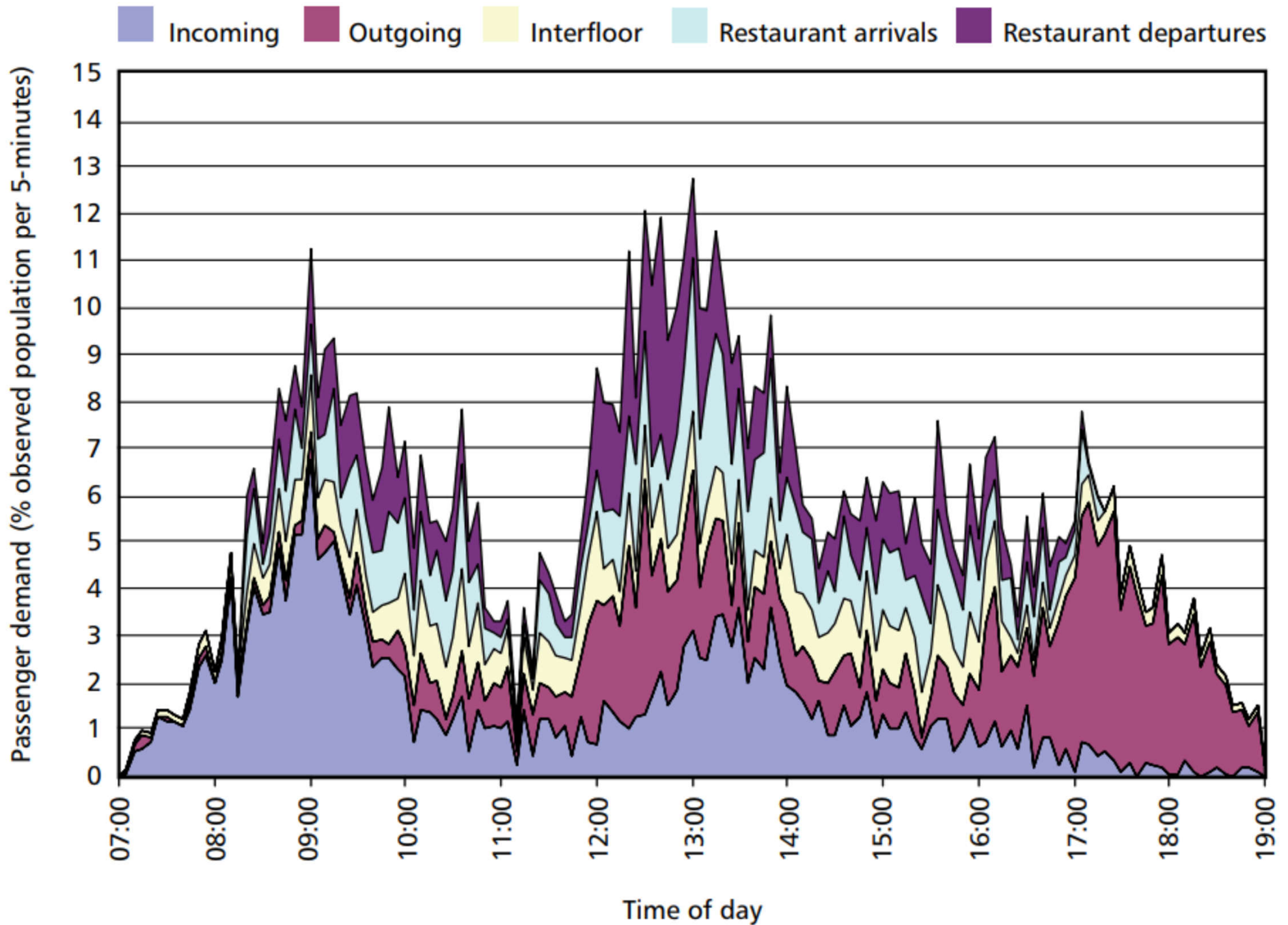

[Source: CIBSE Guide D]

Advanced Traffic Planning

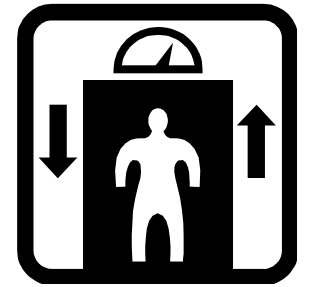

- High-rise commercial buildings

- One lift group alone cannot meet all needs. They are often divided into zones, served by separate lifts groups
- In mega-high-rise buildings (> 50-60 floors), either double-deck lifts are used or lift groups are stacked on top of one another in sky lobby arrangements
 - Shuttle groups serve traffic between the main entrance floor and the sky lobby
 - Local elevator groups start from both the main floor and from the sky lobby
 - Shuttle group criteria: $HC > 16 \% / 5 \text{ min.}; \text{Interval} < 32 \text{ sec}$

Typical lift arrangements in Mega high rise buildings

Traditional groups

Double - Deck arrangements

- Single-Deck local group
- Double-Deck shuttle group
- Double-Deck local group
- Express zone
- Lobby

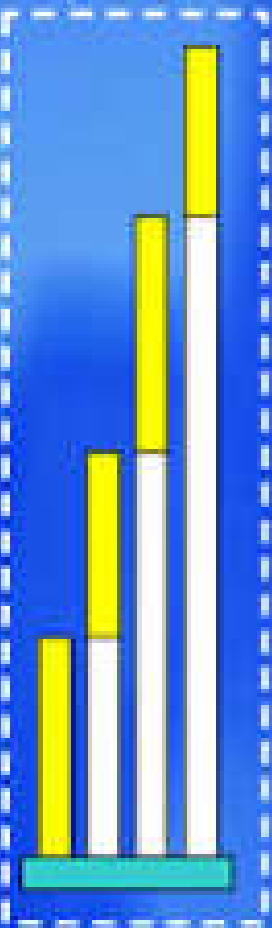

Up to 60 floors

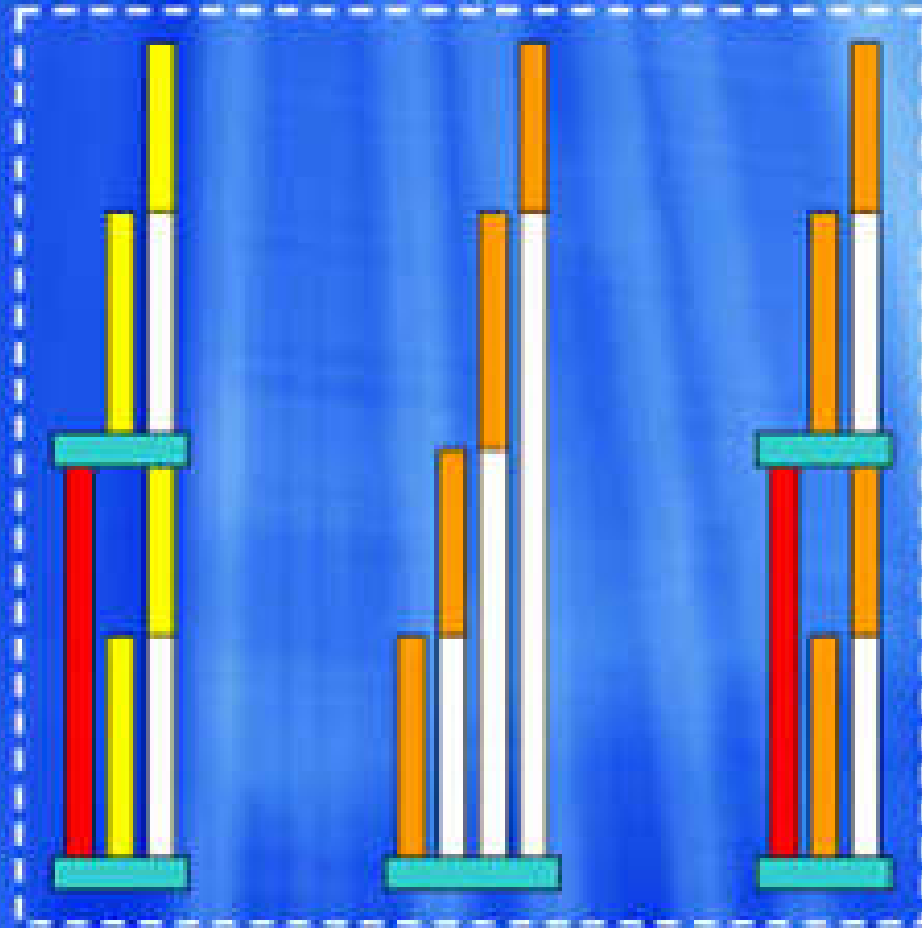

50 - 80 floors

30 - 90 floors

70 - 140 floors

Typical double-deck lifts

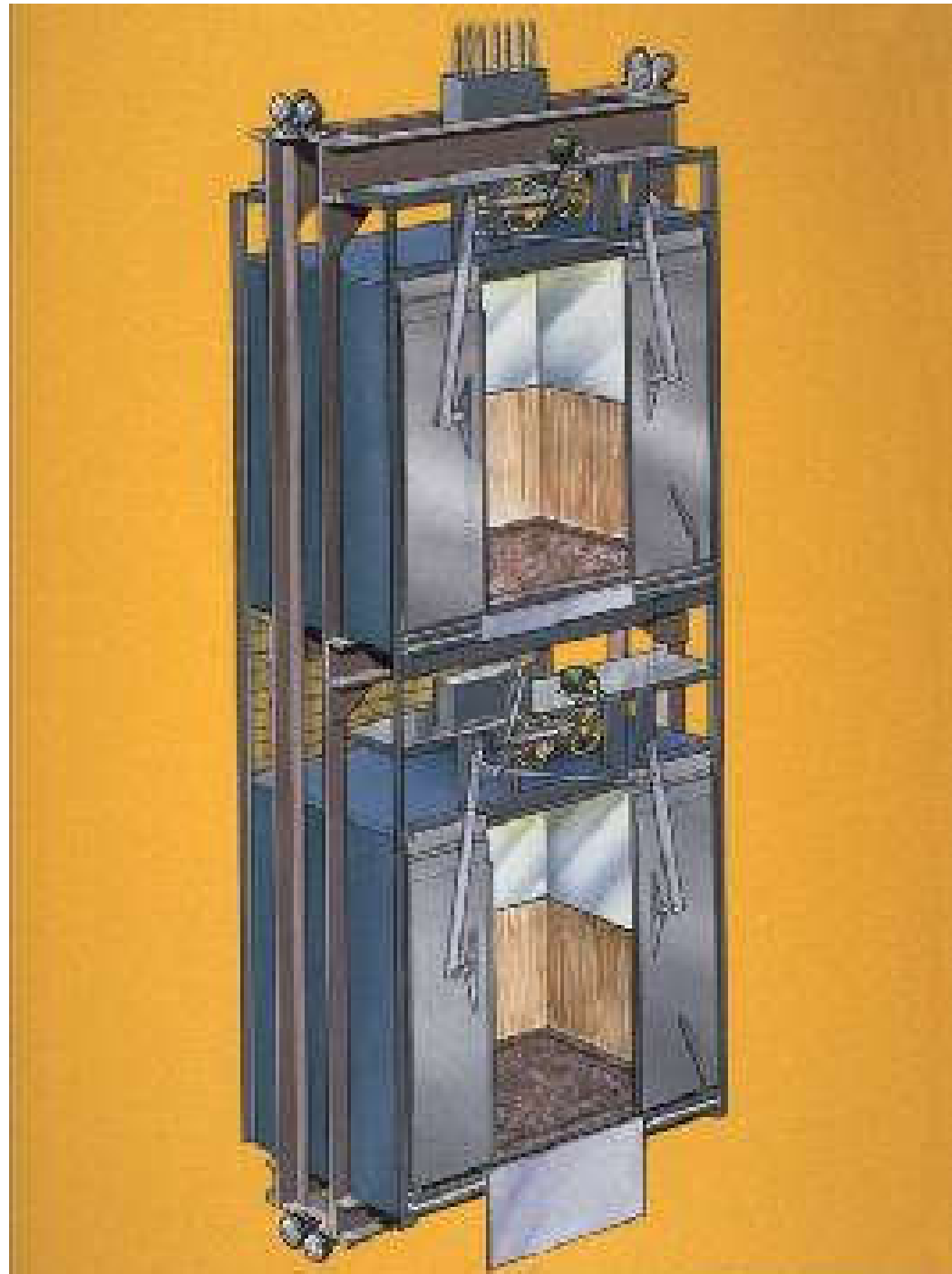

[Source: <http://www.elevator-world.com>]

Twin lift (two independent cars running in one shaft)

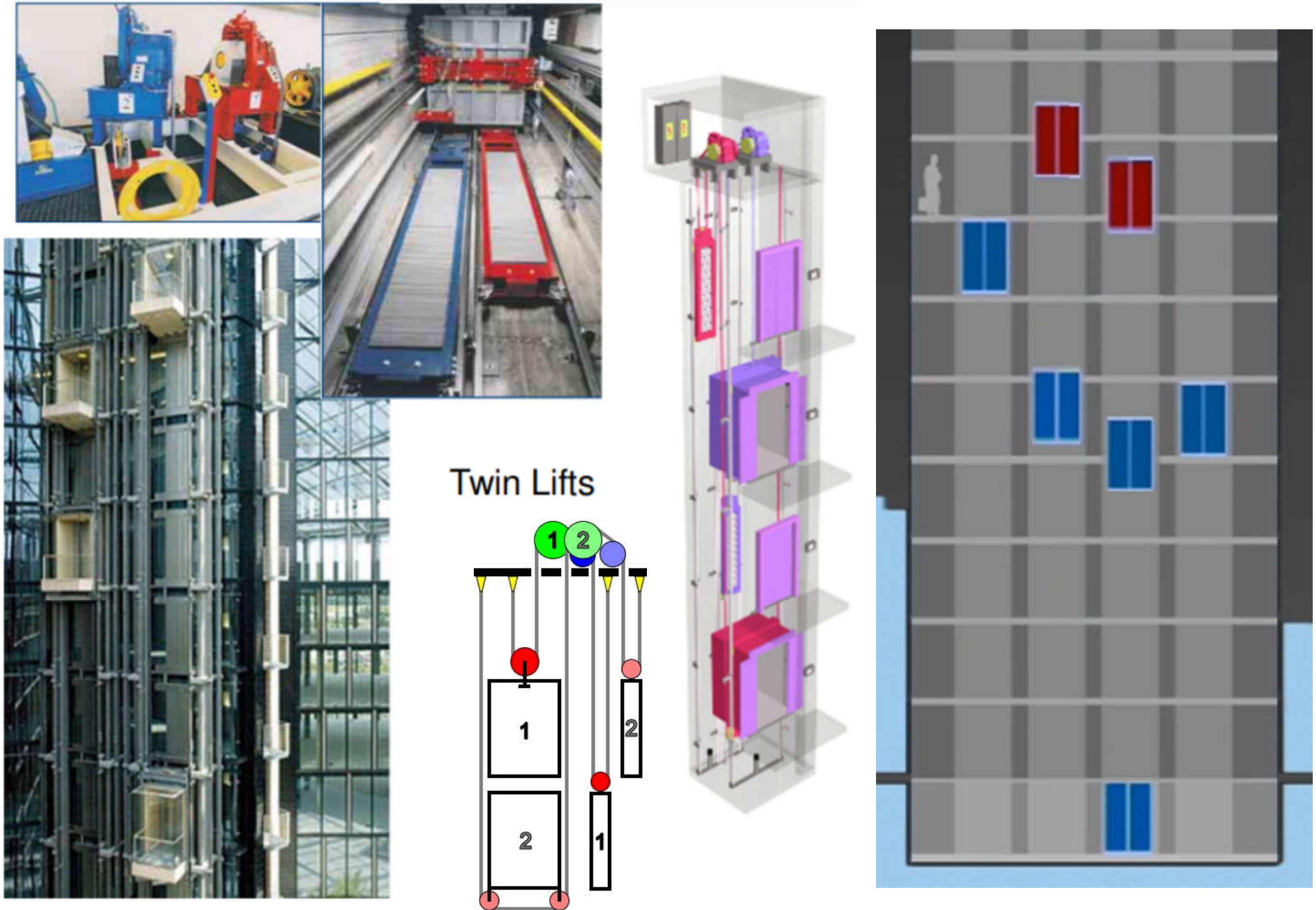

(Source: <https://www.thyssenkruppelevator.com/elevator-products/twin>)

Example user groups and their typical routes in a building

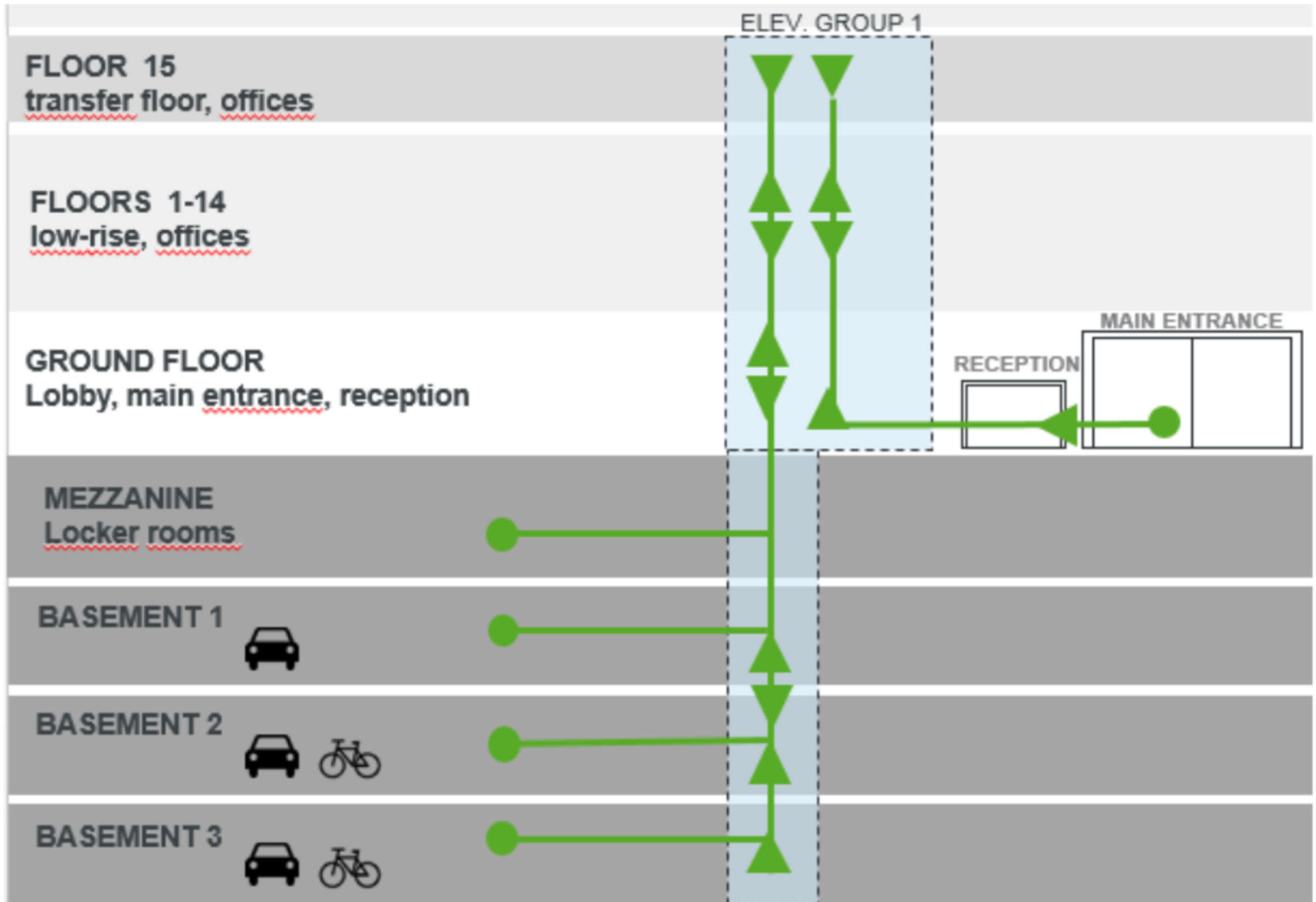

(Source: KONE Corporation, Finland)



Further Reading

- General Planning Guidance for Elevators and Escalators http://ibse.hk/IBTM6010H/planning-elevators_escalators.pdf
- Typical traffic calculation method and examples of traffic calculations (extracted from BS 5655-6:2011) http://ibse.hk/IBTM6010H/BS5655-6-2011_p63-67.pdf
- Lift Information Net 電梯資料網 <http://www.hkelev.com>
 - Elevators 升降機 http://www.hkelev.com/ind_elev.htm
 - Escalators 自動梯 http://www.hkelev.com/ind_esc.htm

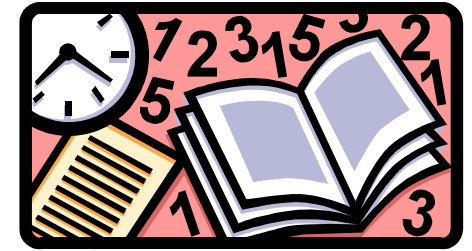

References

- Barney G. C. & Al-Sharif L., 2016. *Elevator Traffic Handbook: Theory and Practice*, Routledge, Abingdon, Oxon.
- CIBSE, 2020. *Transportation Systems in Buildings*, CIBSE Guide D, 6th ed., Chps. 2, 3 & 5, Chartered Institution of Building Services Engineers (CIBSE), London.
- EMSD, 2018. *Code of Practice for Lift Works and Escalator Works*, 2018 Edition, Electrical and Mechanical Services Dept. (EMSD), Hong Kong.
[https://www.emsd.gov.hk/filemanager/en/content_791/CoP%20on%20Lift%20Works%20and%20Escalator%20Works%202018%20Edition%20\(Eng\).pdf](https://www.emsd.gov.hk/filemanager/en/content_791/CoP%20on%20Lift%20Works%20and%20Escalator%20Works%202018%20Edition%20(Eng).pdf)
- Hall F. & Greeno R., 2017. *Building Services Handbook*, 9th ed., Chapter 10, Routledge, Oxon & New York.
- Strakosch, G. R. and Caporale, R. S. (eds.), 2010. *The Vertical Transportation Handbook*, 4th ed., John Wiley & Sons, Hoboken, N.J.