

Basic Concepts of Lighting

Ir Dr. Sam C. M. Hui

E-mail: sam.cmhui@gmail.com

<http://ibse.hk/cmhui/>

Contents



- What is light?
- How the human eye works?
- Functions of the human eye
- What lighting can do?
- Lighting quality

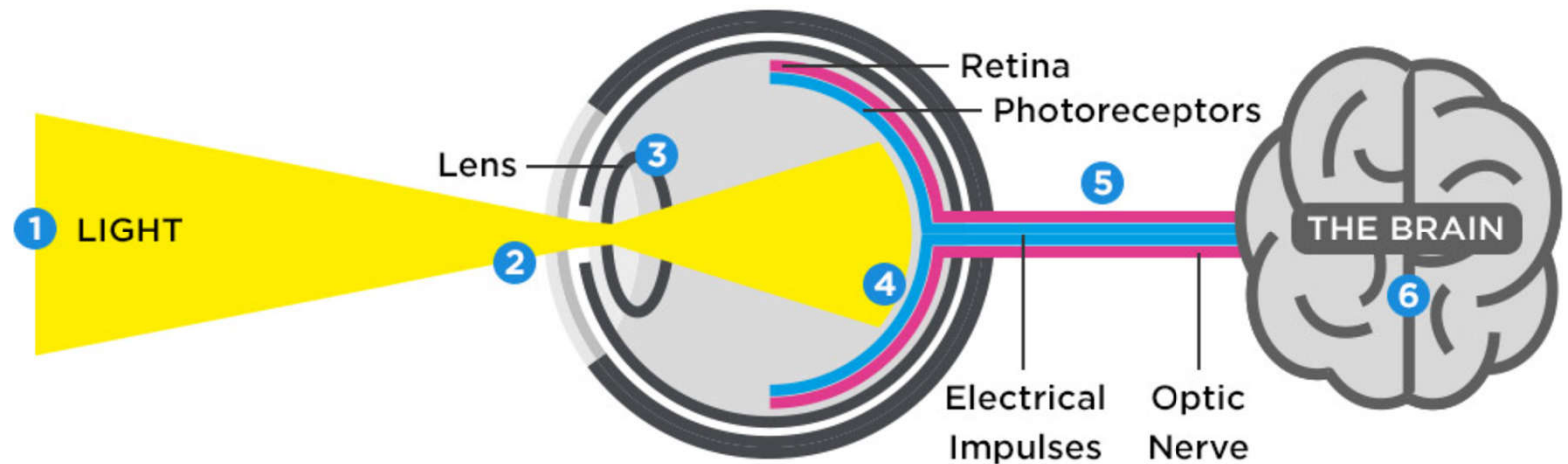

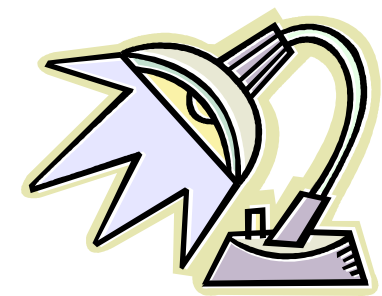

What is light?

- The large majority of our impressions of the world come through our **eyes**, and **light** is necessary to **vision**
- Light is therefore the medium through which a majority of people perceive the world



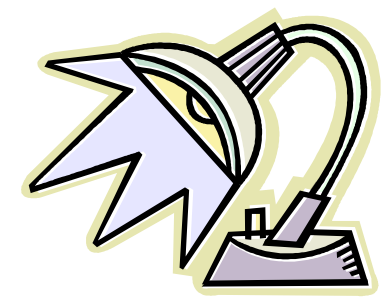

What is light?

- What is *Light*?
 - Light is a form of electromagnetic radiation with an electric field & a magnetic field oriented at right angles and varies in magnitude in a direction perpendicular to the propagation direction

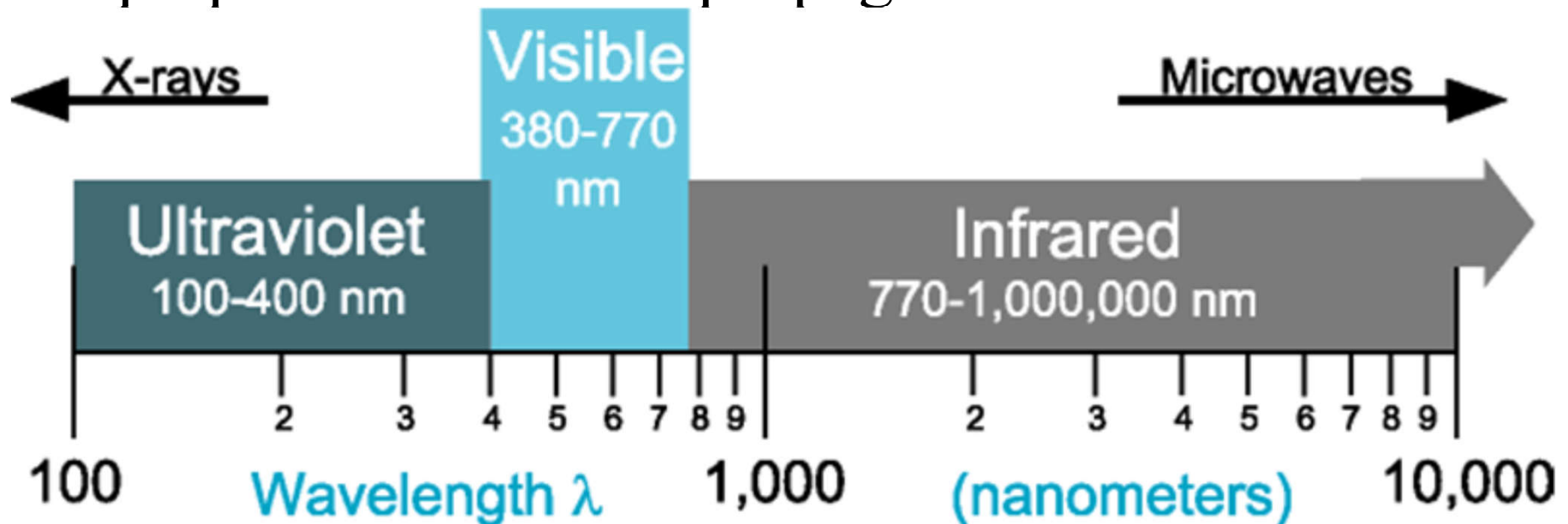

Basic properties of electromagnetic wave

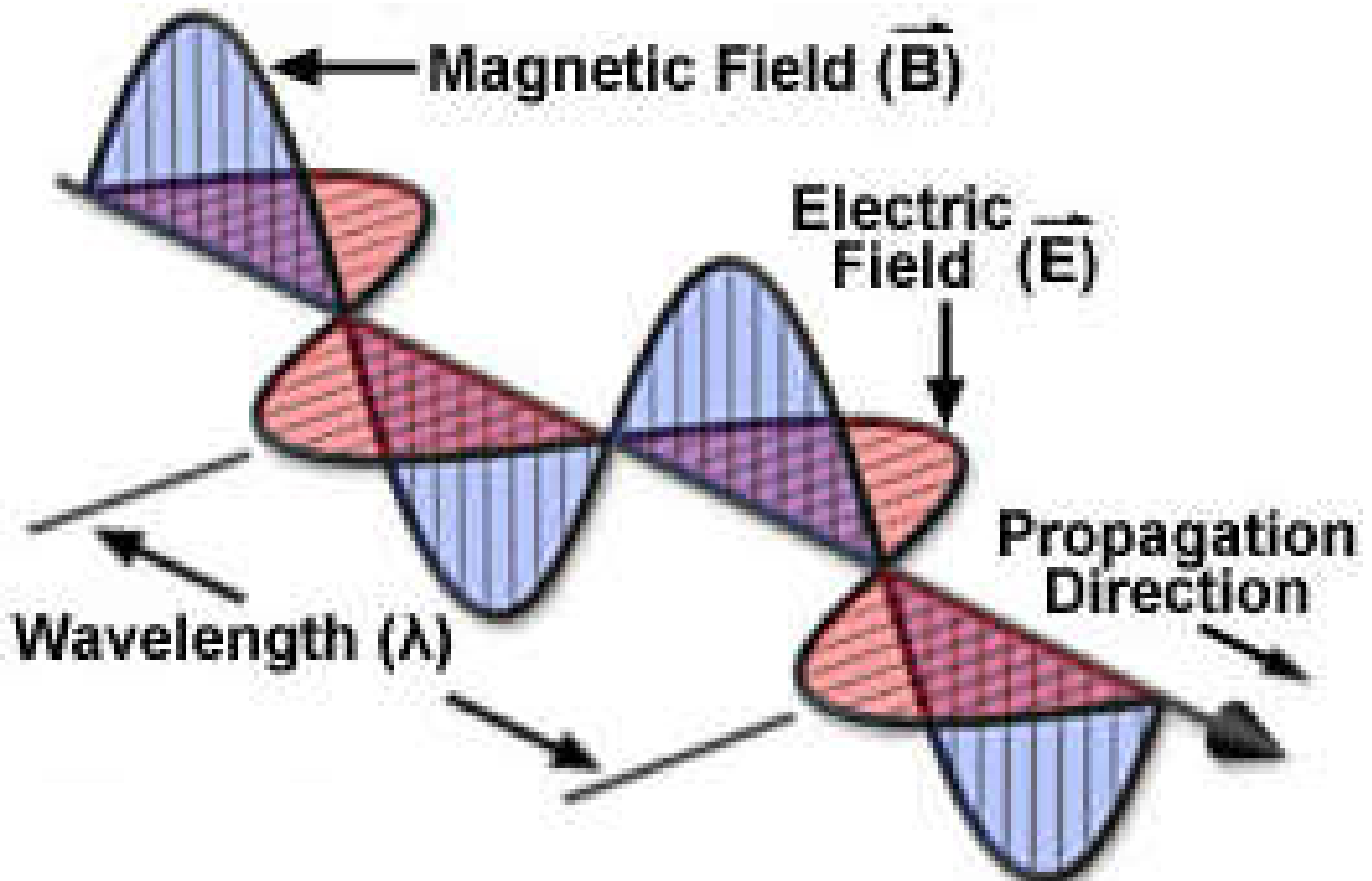

Electromagnetic Radiation Spectrum

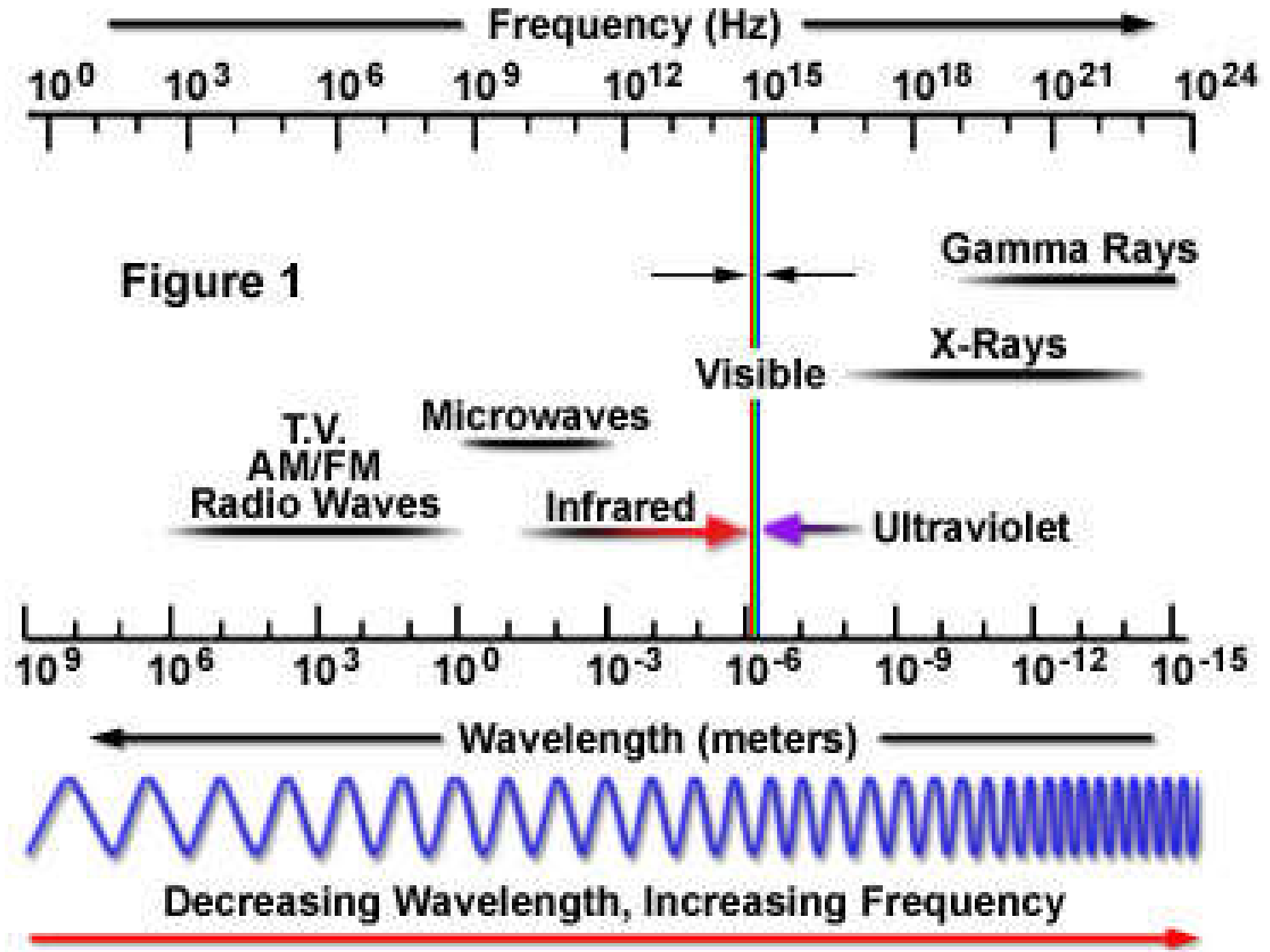

Visible spectrum of light

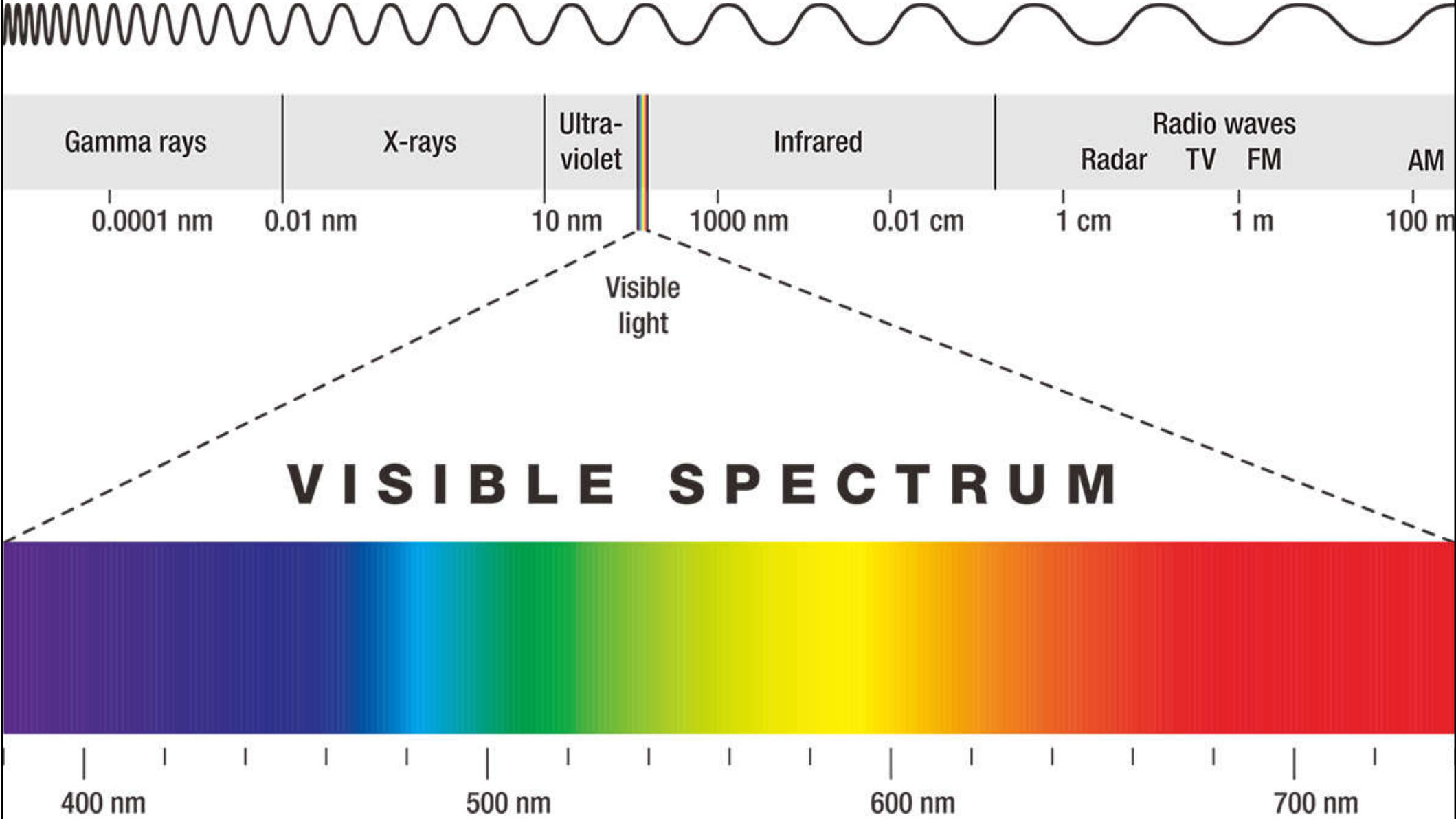

(Source: <https://www.manufacturer.lighting/info/245/>)

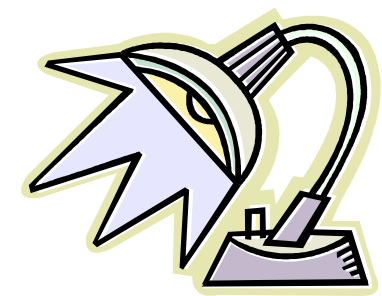

What is light?

- Electromagnetic spectrum

- Visible light (380 to 760 nm)

- Mr. ROY G. BIV (Red, Orange, Yellow, Green, Blue, Indigo, Violet)

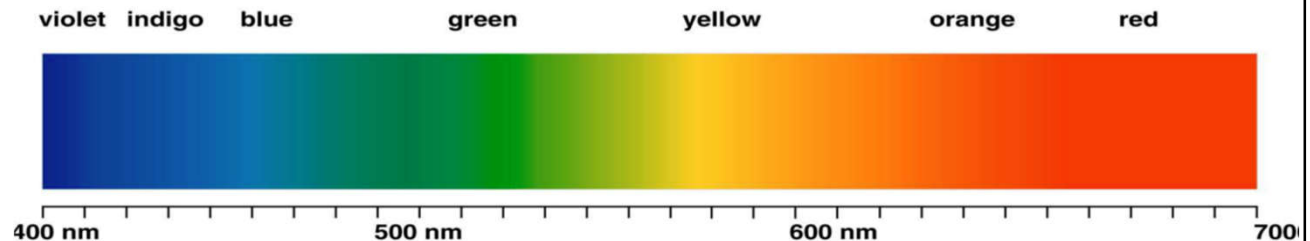

- Ultraviolet (100 to 380 nm)

- Infrared (760 to 1,000,000 nm)

- Speed of light (in air) = 299 702 547 m/s

- = (wavelength, metres) x (frequency, Hertz)

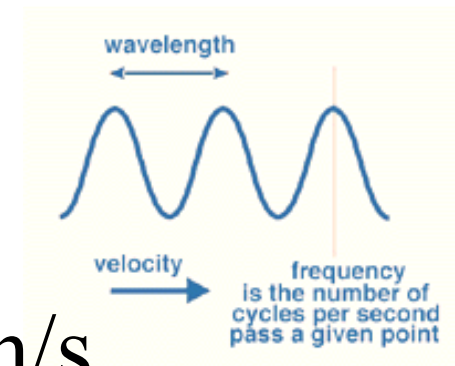

Planck's equation showing photon energy vs. wavelength

Q = photo energy (J), h = Planck's constant (6.623×10^{-34} J s),
 c = speed of light (2.998×10^8 m s⁻¹), λ = wavelength of radiation (m)

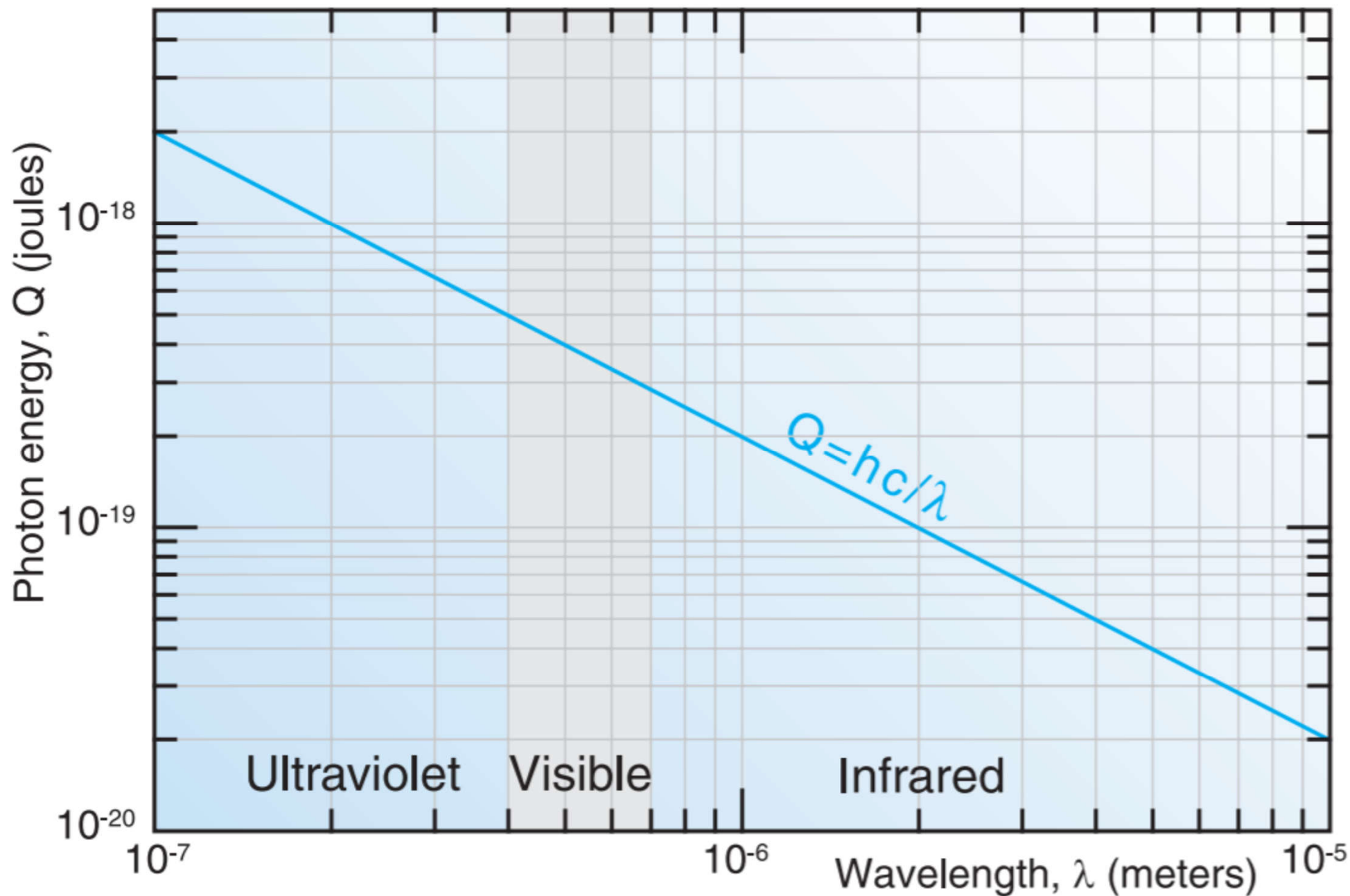

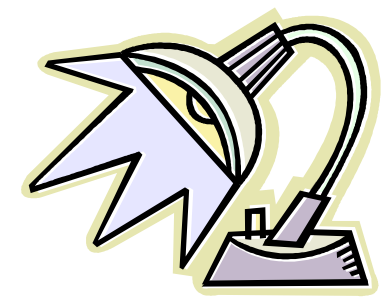

What is light?

- The behaviour of light
 - Inverse square law $E = I / d^2$
 - Cosine law - the irradiance falling on any surface varies with the cosine of the incident angle
 - $E_{\theta} = E \cos \theta = (I / d^2) \cos \theta$
 - Optical properties
 - Reflection (specular, diffuse, spread, mixed, scattered)
 - Transmission and absorption
 - Refraction
 - Diffraction
 - Scattering and polarization

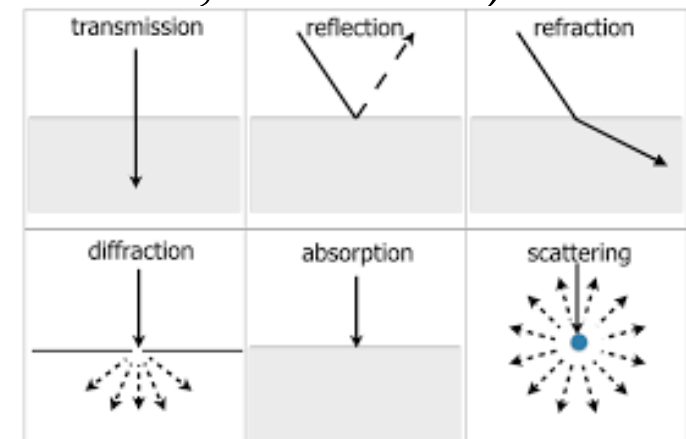

Inverse square law

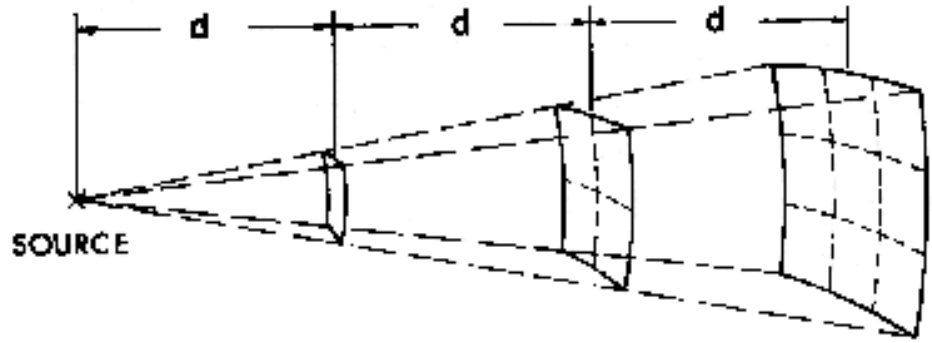

Cosine law

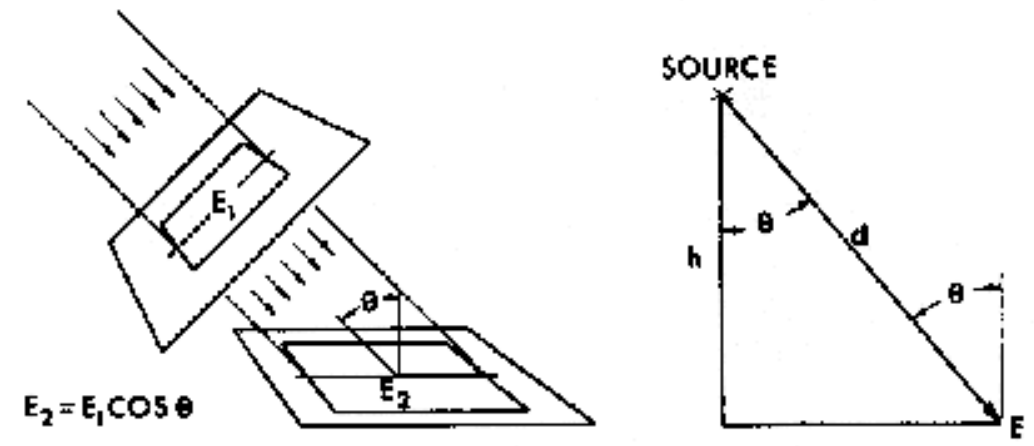

TYPES OF LIGHT MODIFICATION

TRANSMISSION
(Diffuser)
Opal Glass
or Plastic

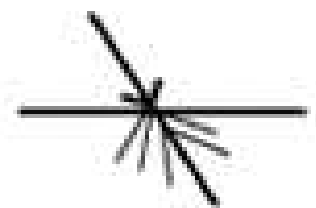

ABSORPTION
Matte Black
Paint

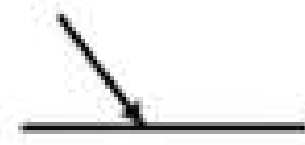

REFRACTION
Clear Glass

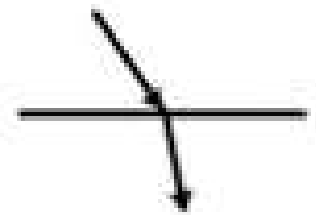

POLARIZATION

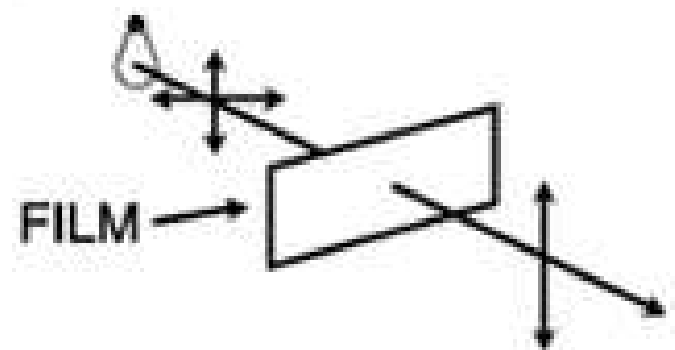

REFLECTION
Polished
Metal



Measurement of light

Luminous flux Φ

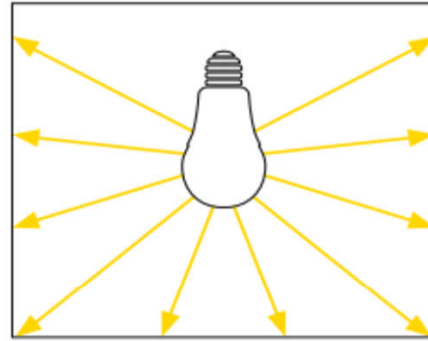

Lumen [lm]

$$I = \frac{\Phi}{\Omega}$$

$$E = \frac{\Phi}{A}$$

Luminous flux –
Luminous intensity –
Illuminance –
Luminance

Luminous intensity I

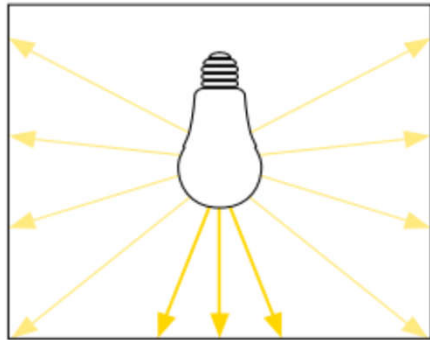

Candela [lm/sr]=[cd]

Illuminance E

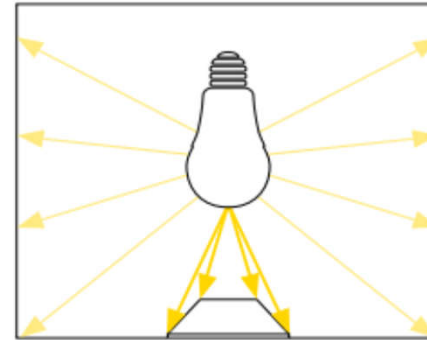

Lux [lm/m²]=[lx]

Ω = solid angle into which luminous flux is emitted

A = area hit by luminous flux

$A_L \cdot \cos \epsilon$ = visible areas of light source

ρ = reflectance of area

π = 3.14

* = for diffuse surface areas

Luminance L

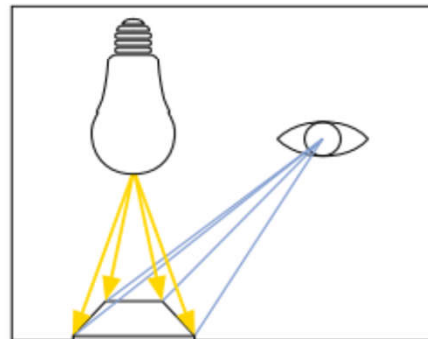

[lm/sr*m²]=[cd/m²]

$$L = \frac{I}{A_L \cdot \cos \epsilon}$$

$$L = \frac{E \cdot \rho^*}{\pi}$$

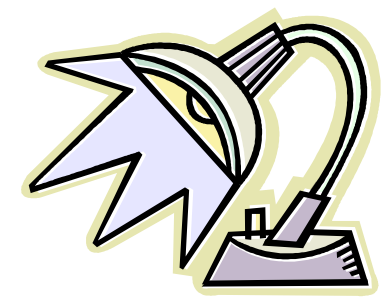

What is light?

- Tools to measure light:

- 1. Photometer (measures light intensity)

- (a) Luminance meters - determine visible energy output of a light source
 - (b) Illuminance meters - measure visible energy falling on an object's surface

- 2. Integrating sphere (measure luminous flux)

- 3. Spectrometer (assess spectral components)

- 4. Light/Lux meter (measure light levels)



Light measurement tools



Luminance meter



Illuminance meters



Integrating sphere



Spectrometer



Light/Lux meter

Essential elements of light and human vision

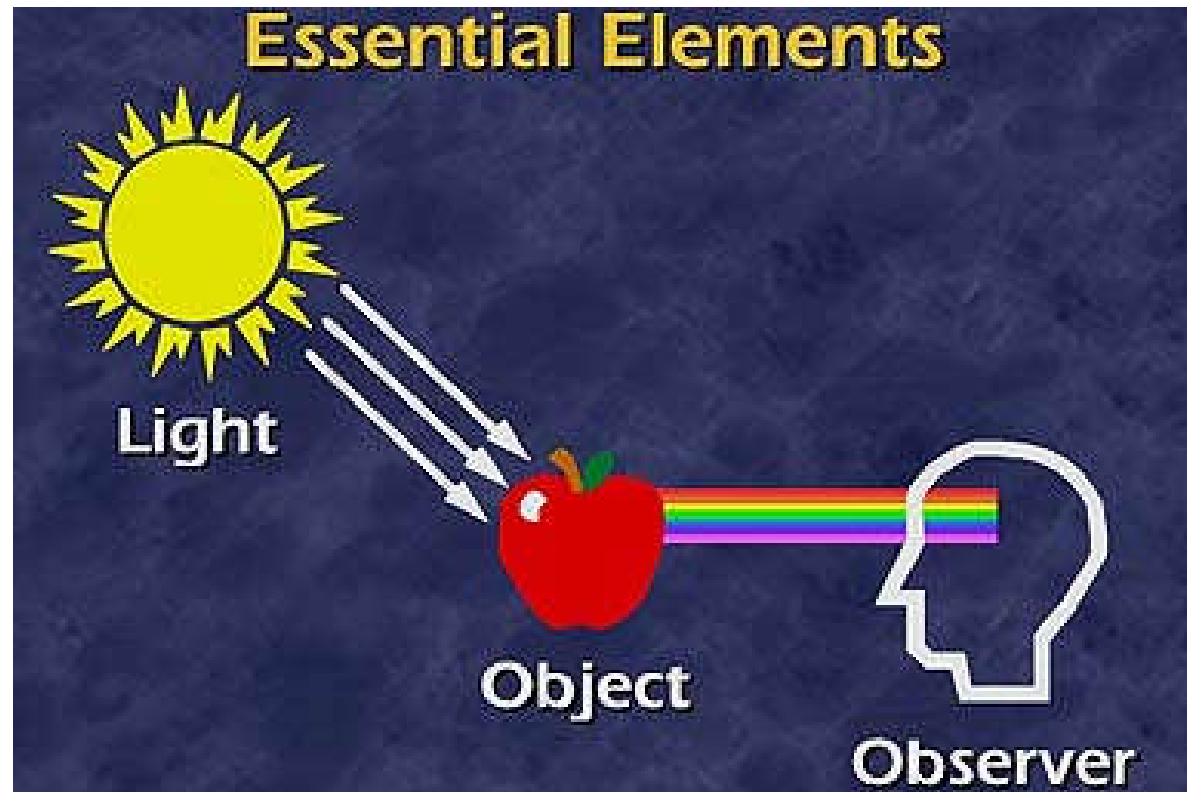
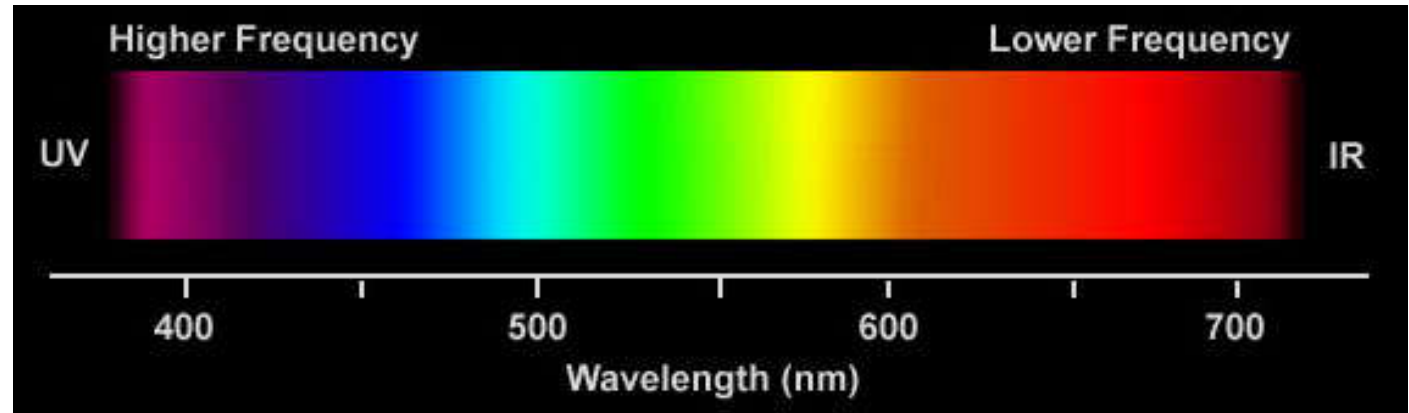
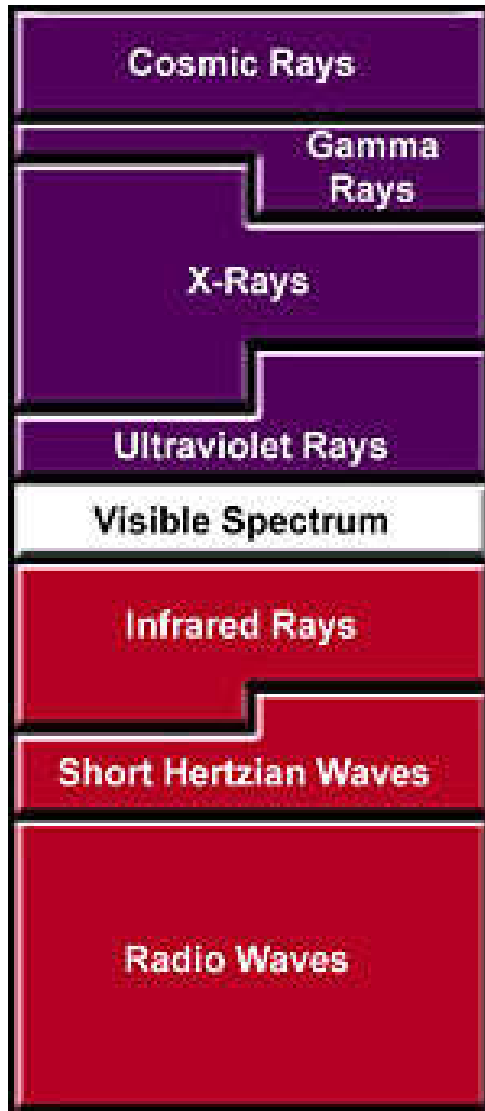

Sight and brain pathway in human body

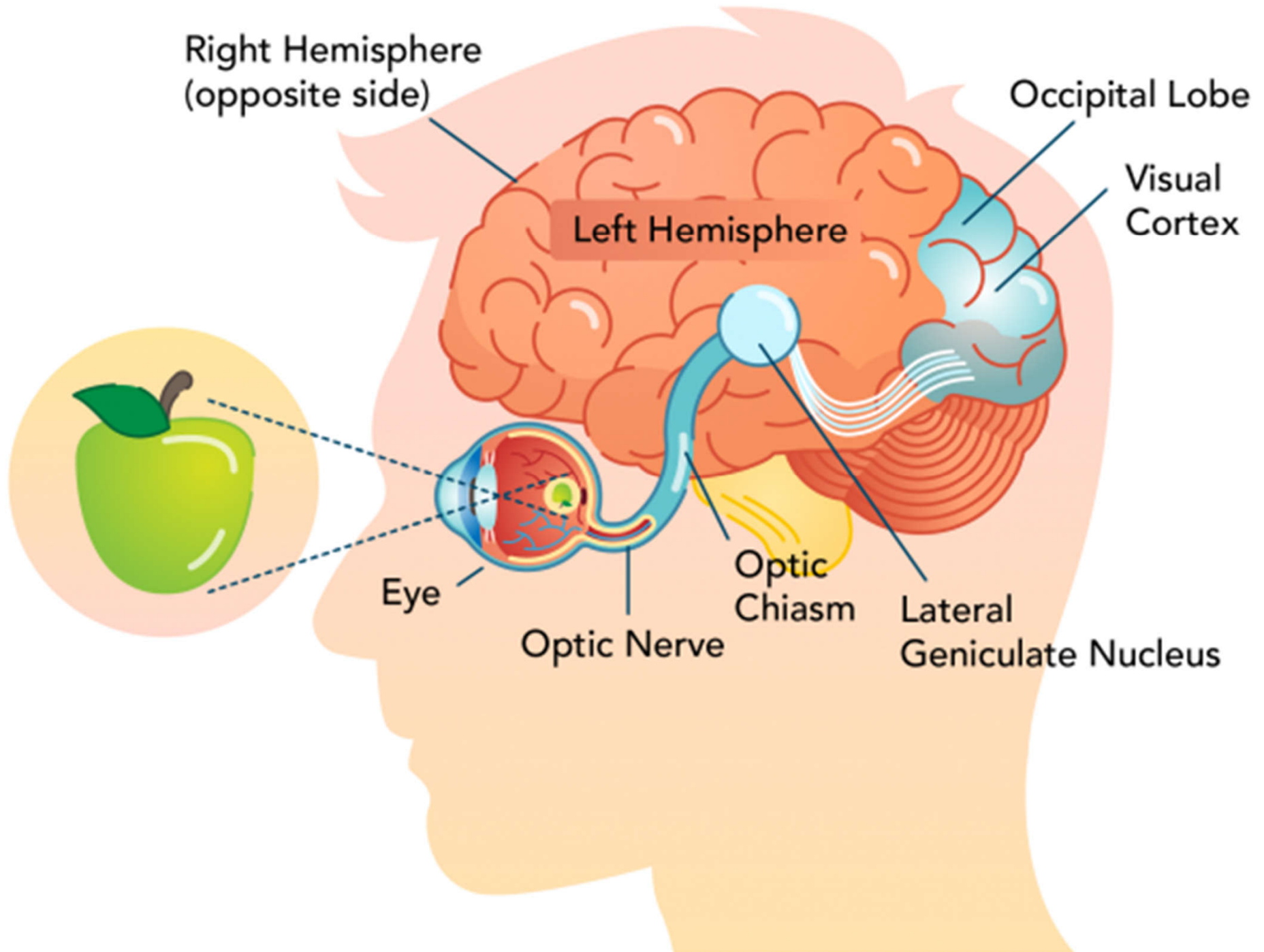

How the human eye works?

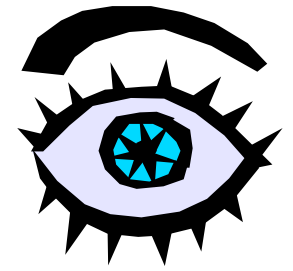

- The camera and the eye
 - Similar principles
- Structure of human eye
 - 1. Optical elements
 - 2. The retina
 - 3. Photoreceptors

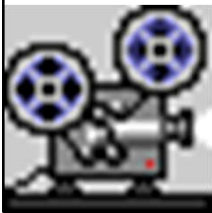
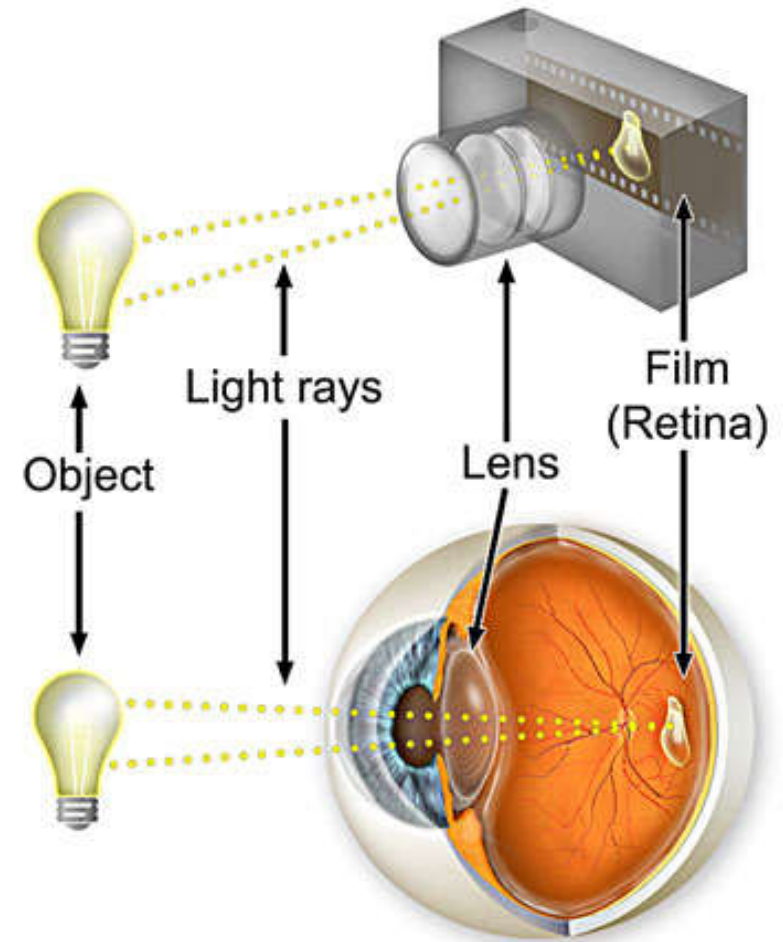

Video: A Journey Through the Human Eye: How We See (2:39) <https://youtu.be/gvozcv8pS3c>

Structure of the human eye

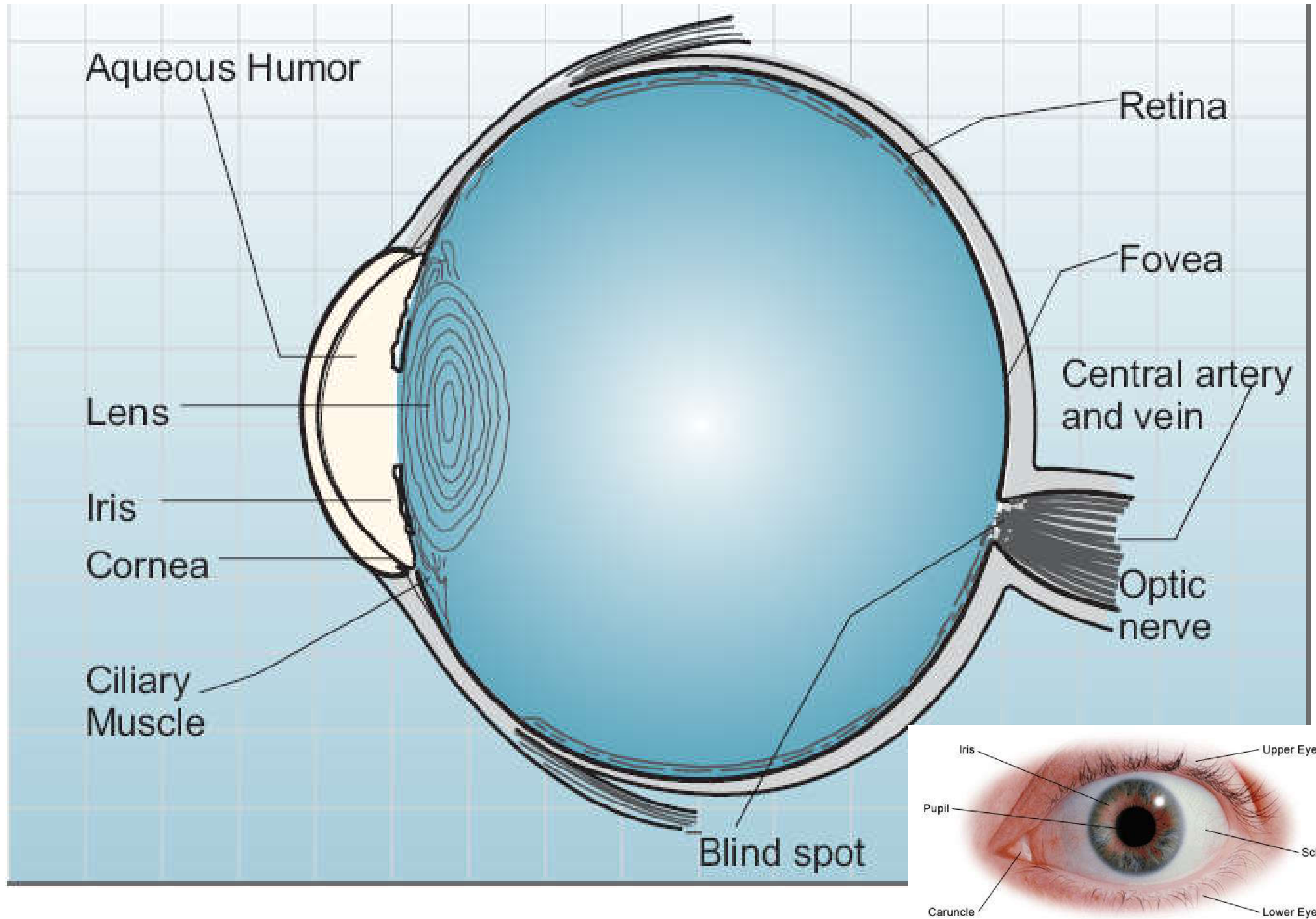

(Source: Source: Advanced Lighting Guidelines 2001, adapted from IESNA Lighting Handbook, 9th ed.)

How the human eye works?

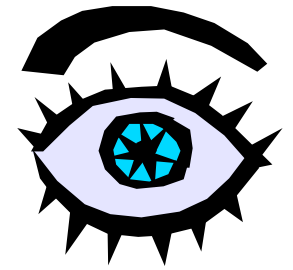

• 1. Optical elements

- Cornea 角膜 – first “lens”, 70% of optical power
- Sclera 鞏膜 – whites of the eye
- Aqueous humour – liquid between cornea & iris
- Iris 虹膜 – coloured muscular ring around pupil
- Pupil 瞳孔 – hole into which light enters eye
- Crystalline lens – 2nd lens, 30% of optical power
- Vitreous humour – fluid filling the eye

(* See also <http://hyperphysics.phy-astr.gsu.edu/hbase/vision/eye.html>
and http://en.wikipedia.org/wiki/Human_eye)

How the human eye works?

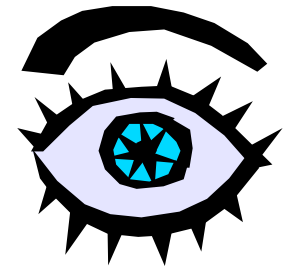

- 2. The retina 視網膜
 - Photoreceptors
 - Fovea – highly concentrated 2 degree field allowing colour and fine detail vision
 - Optic disk – “blind spot” pathway to end of the optic nerve (deficient in receptors)
- 3. Photoreceptors
 - Rods – 120 millions per eye
 - Cones – 8 millions per eye

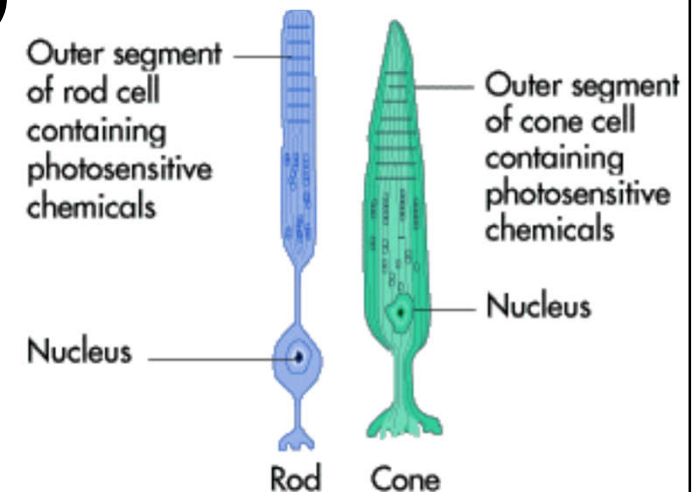

Human eye and photoreceptors in the retina

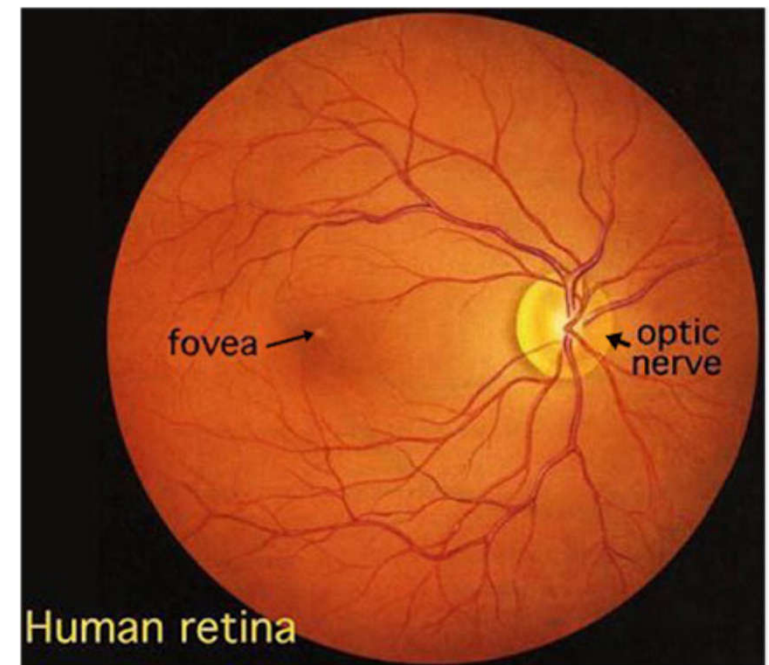
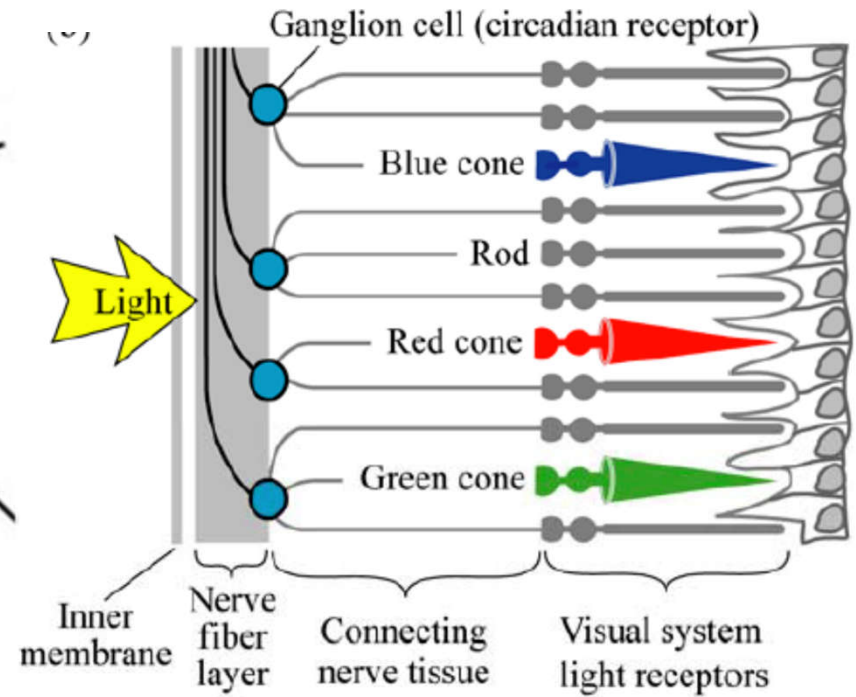
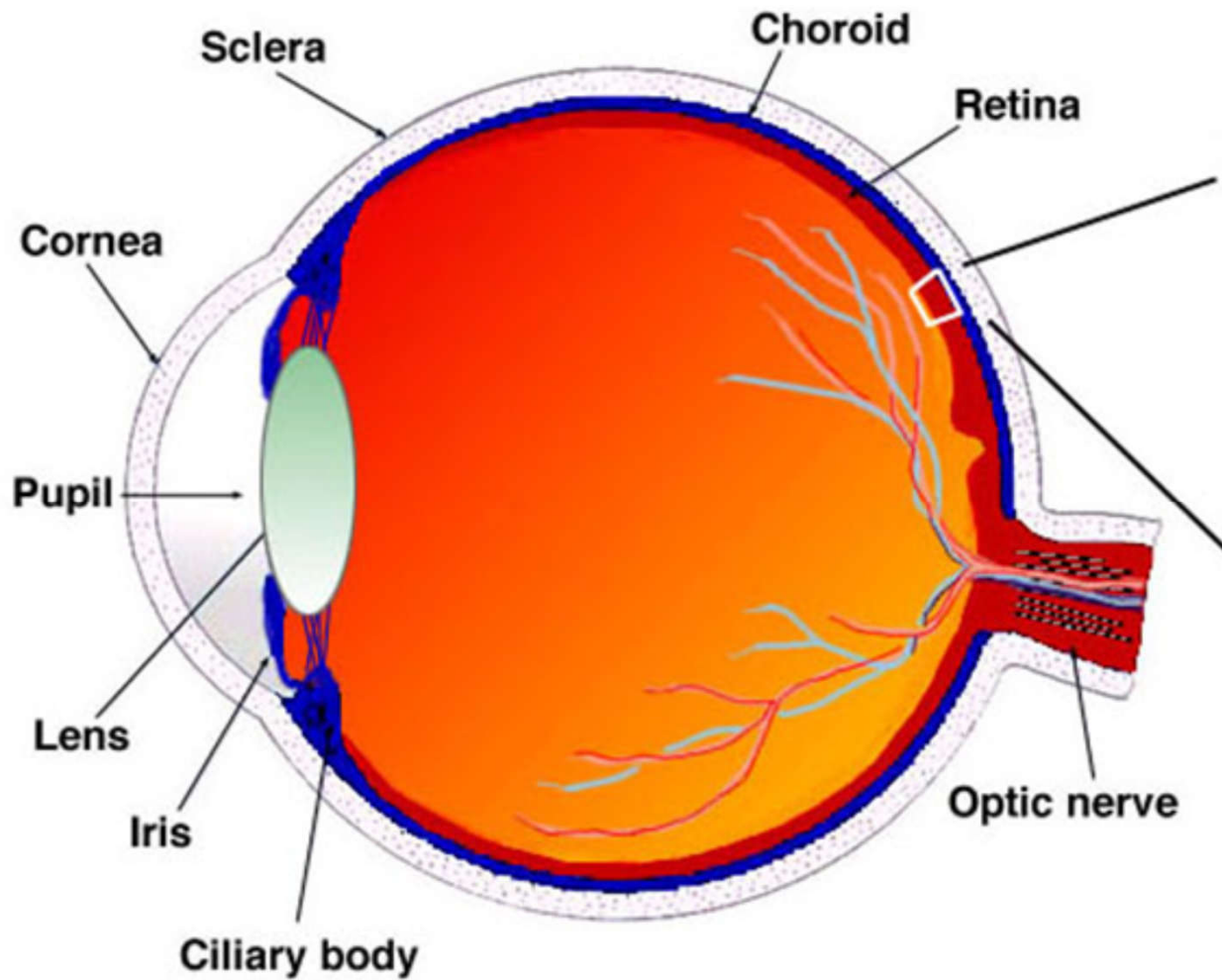

Microscopic anatomy of the retina

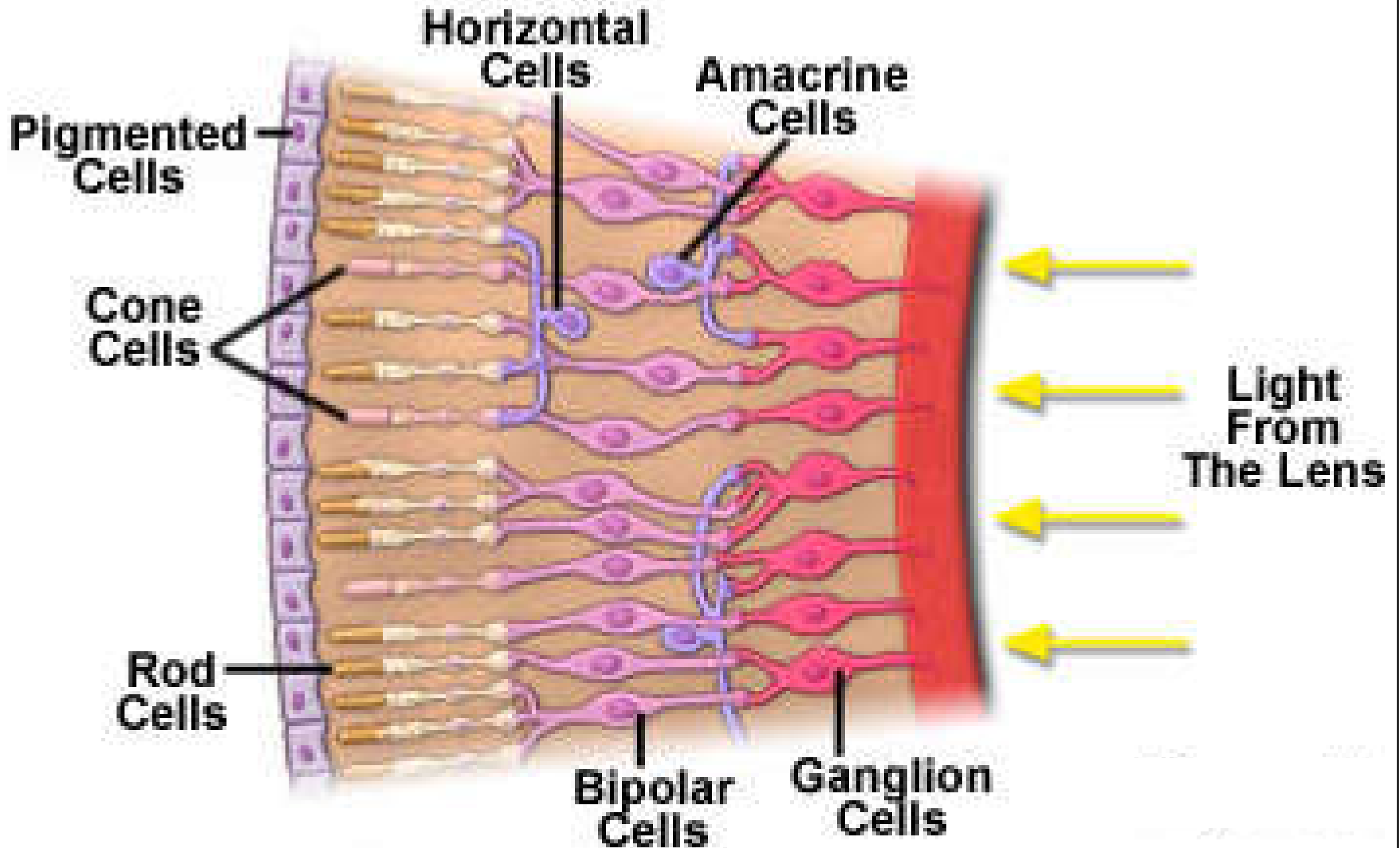

Distribution of rods and cones in the retina

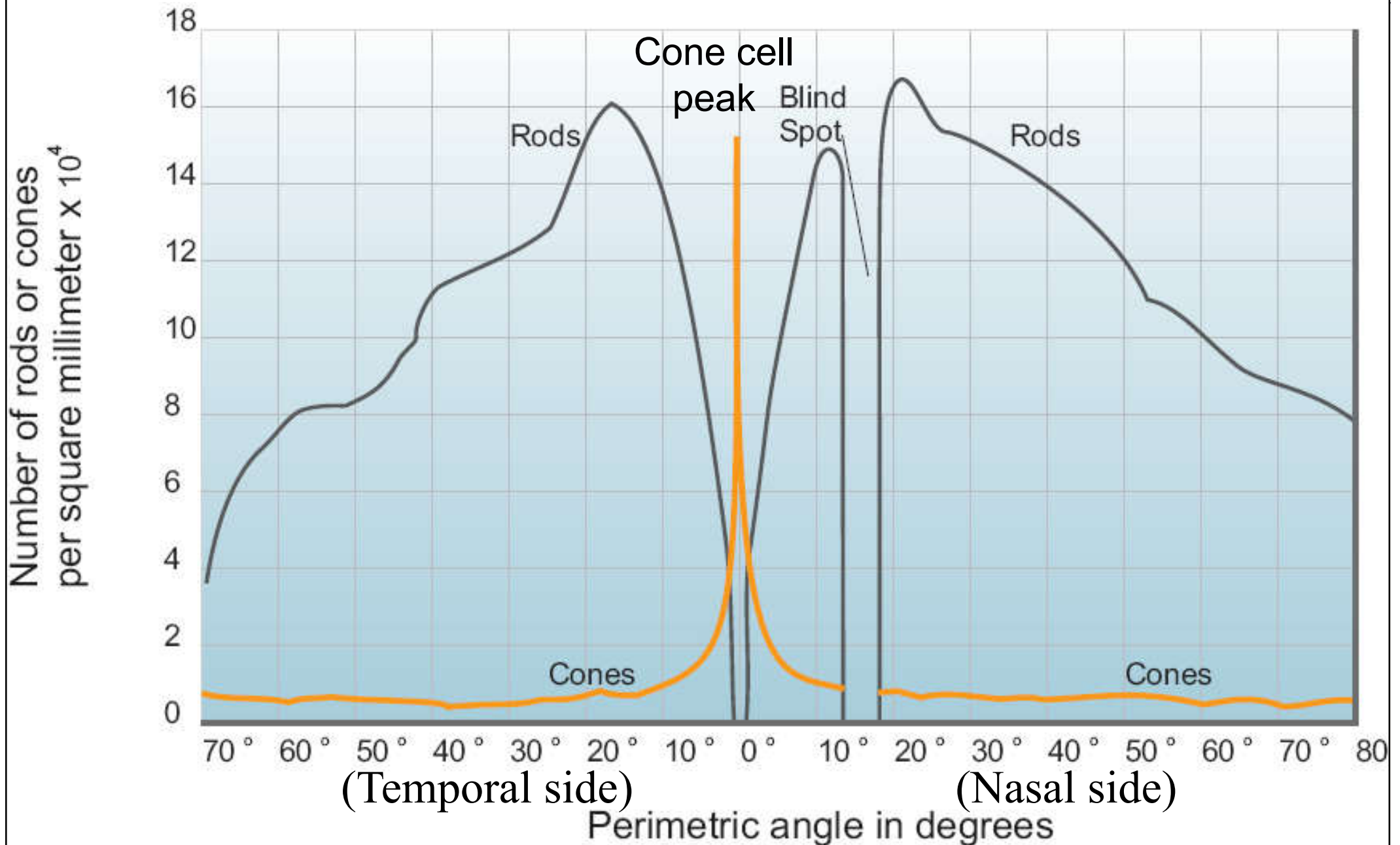

Absorption spectra of the four human visual pigments

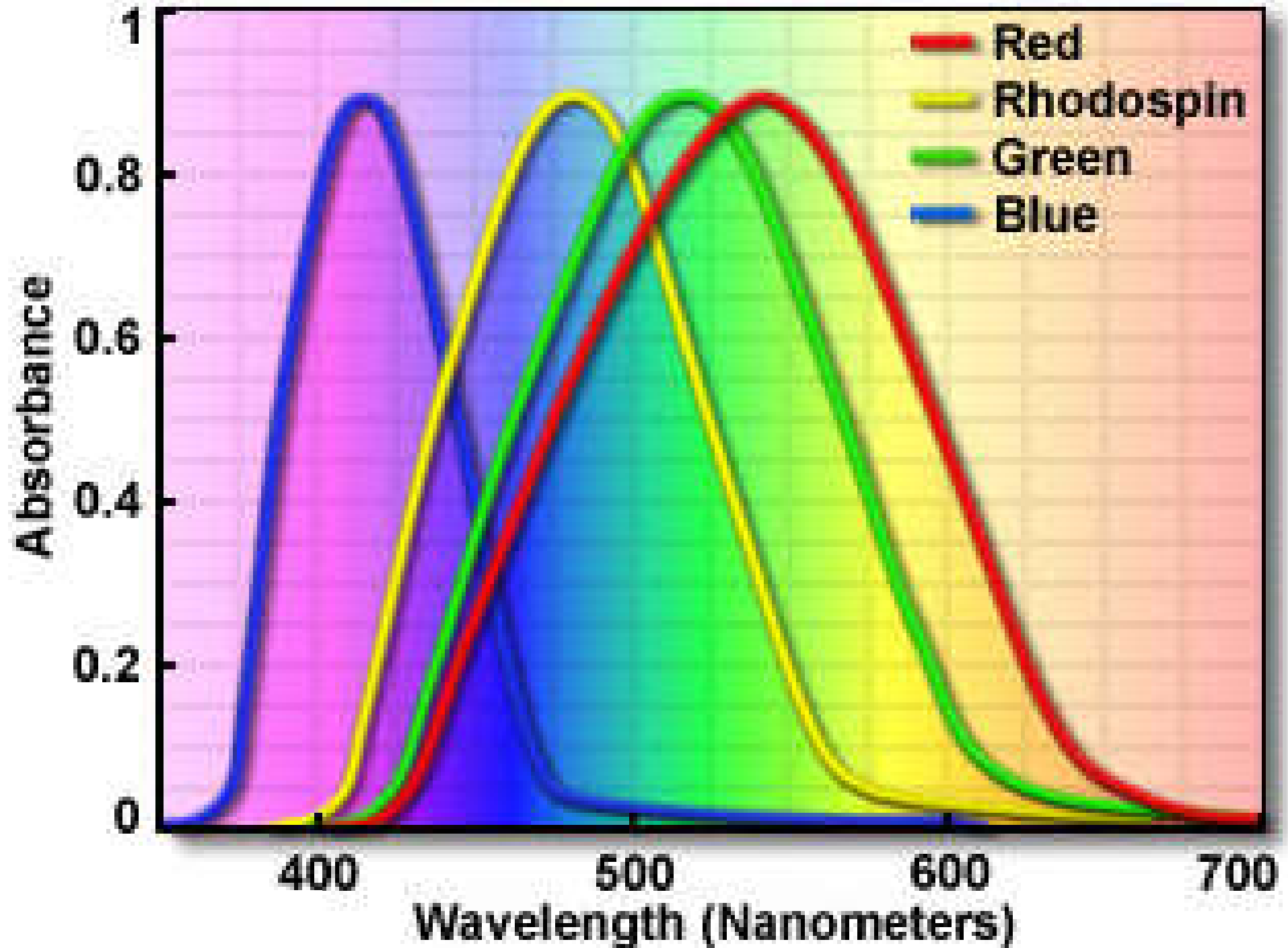

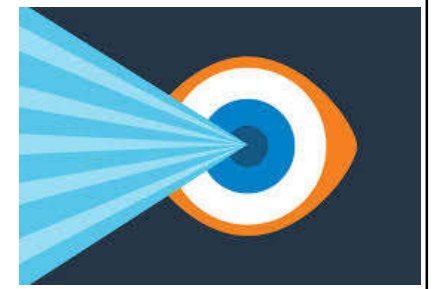

Functions of the human eye

- Functions performed by the eye
 - 1. Adaptation
 - 2. Accommodation
 - 3. Eye movements

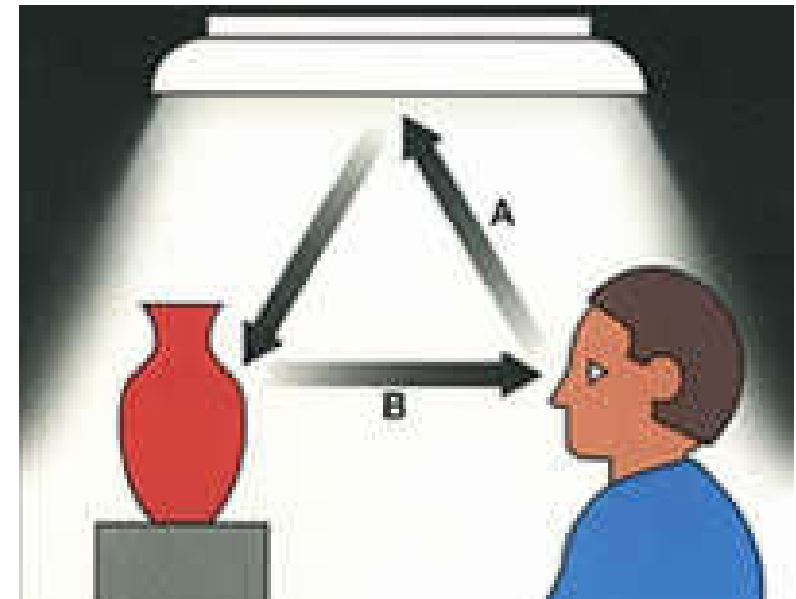
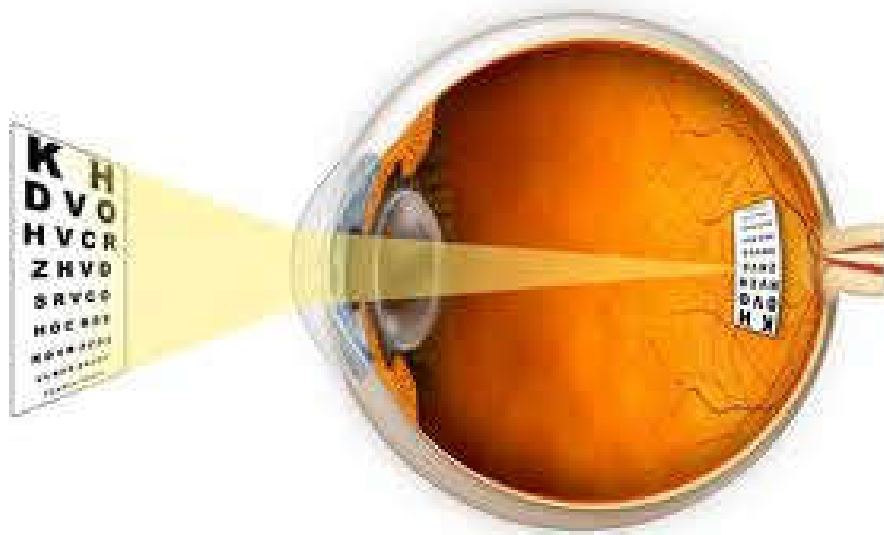

Functions of the human eye

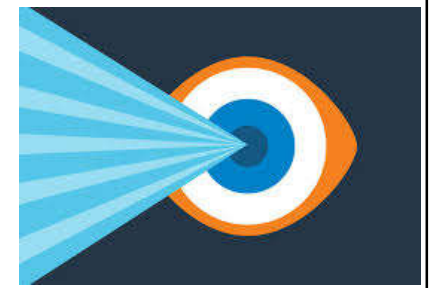

- 1. Adaptation

- The process through which the eye changes its sensitivity to respond to different levels of light stimulation
 - Such as from dim “moonlight” to clear sky “daylight”
 - May take > 60 minutes for complete dark adaptation
- Pupil size – 64 distinct magnitudes of control
 - Accounts for quantity of light entering eye and depth of field
- Photochemical adaptation – over 1,000 levels

Adaptation time from light to dark

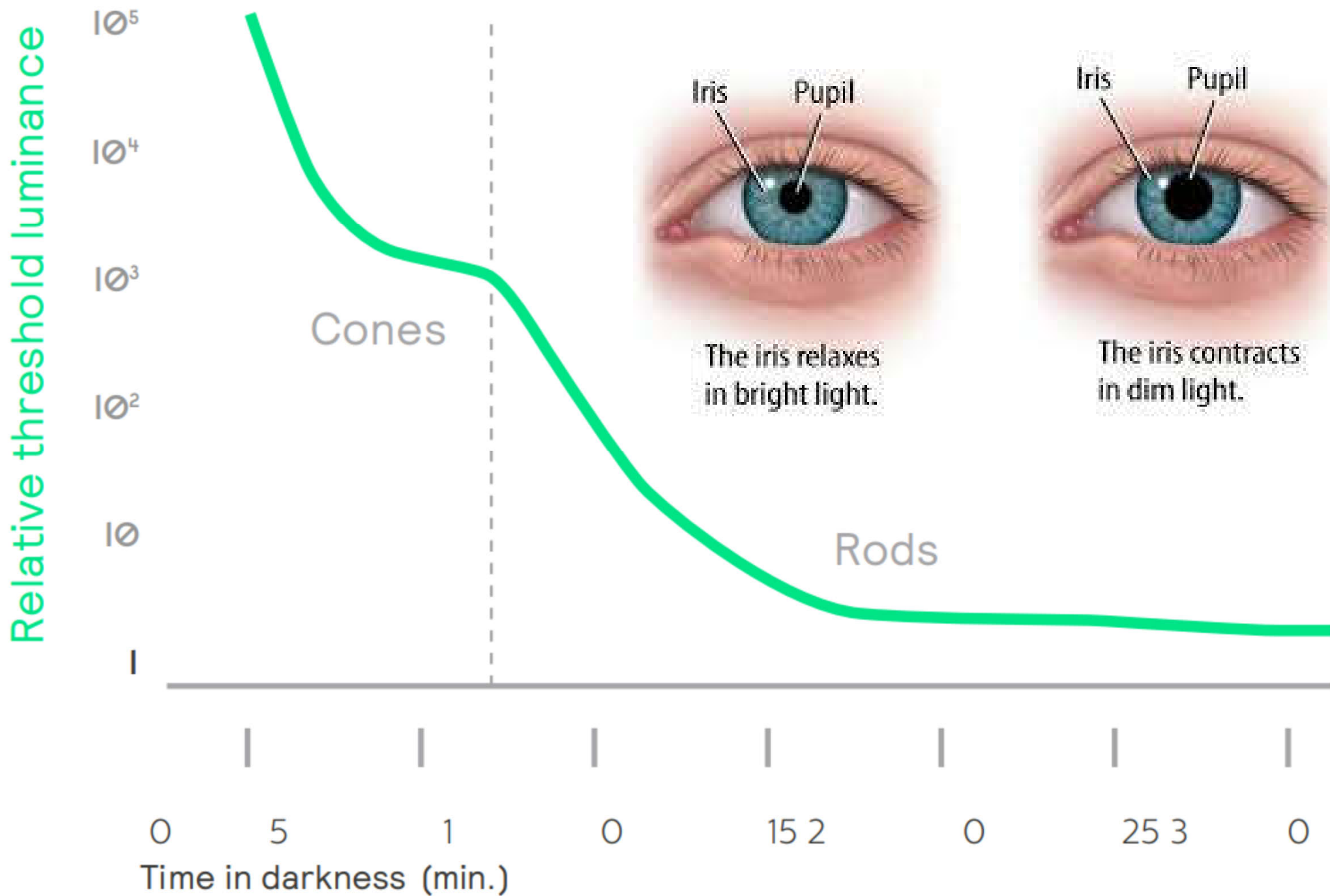

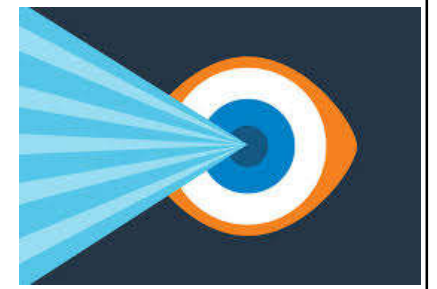

Functions of the human eye

• 2. Accommodation

- A process to focus images onto the retina by adjusting the curvature of the lens (by tightening the ciliary muscles)

- *Near point* - closest distance at which objects can be focused (about 100-750 mm)

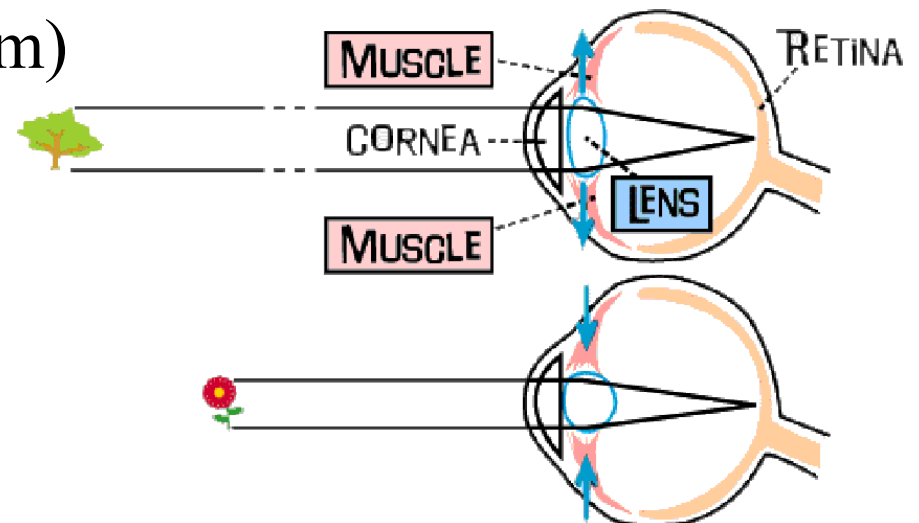

(* See also <http://hyperphysics.phy-astr.gsu.edu/hbase/vision/accom.html>)

Human eye accommodation range

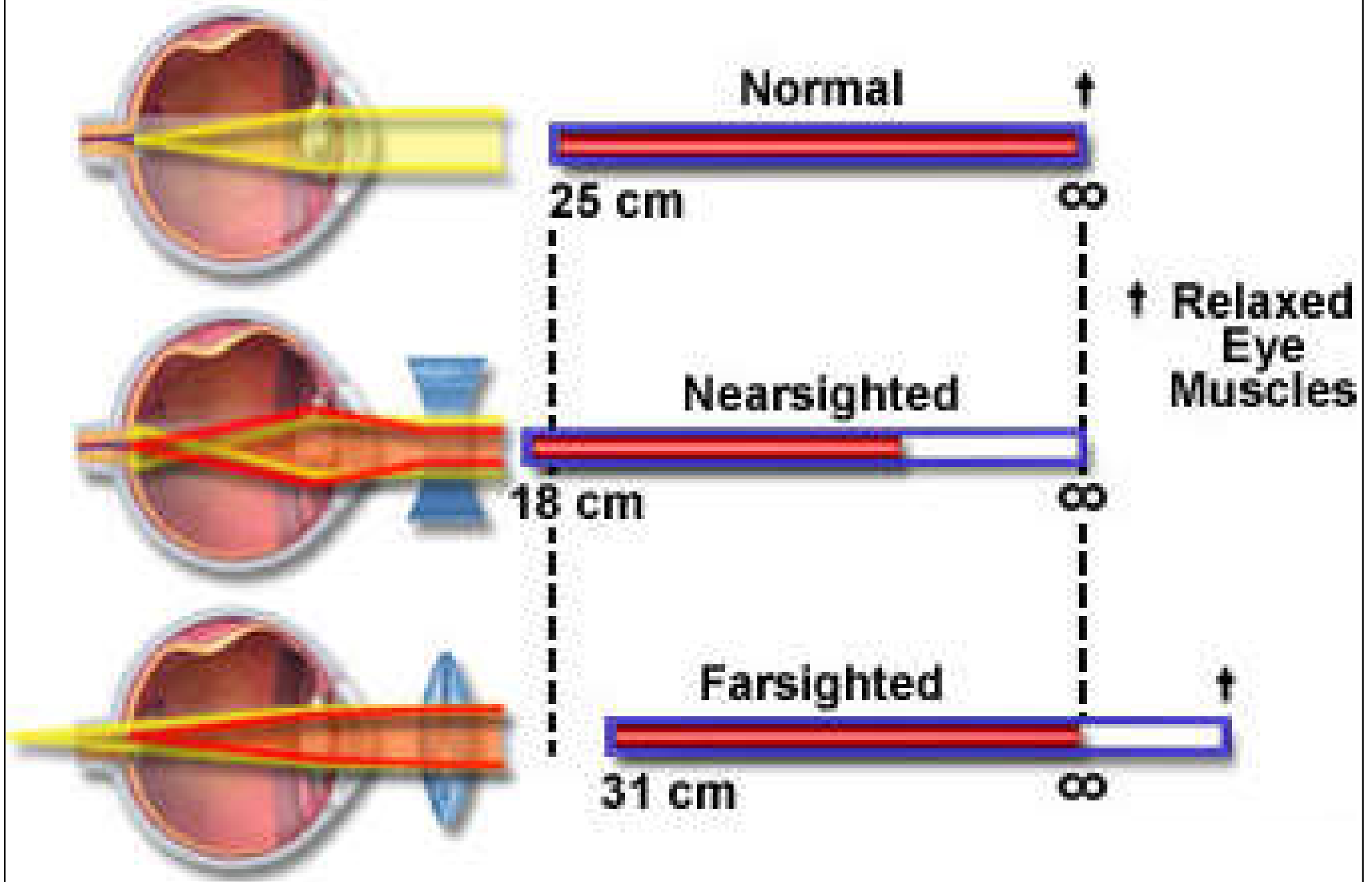

Functions of the human eye

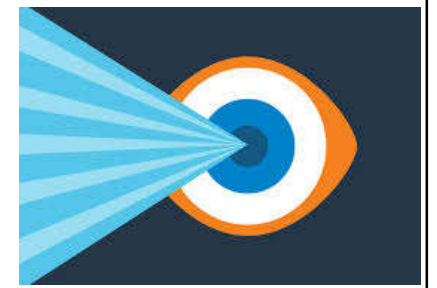

- 3. Eye movements

- Each eye has six muscles to control the movement of the eye
- Smooth pursuit movement – binocular
- Saccadic movement – “jumping” focus when scanning areas
- Disjunctive eye movements – opposing eye movements for different distances

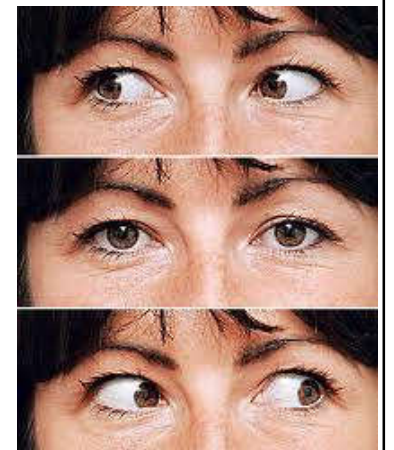

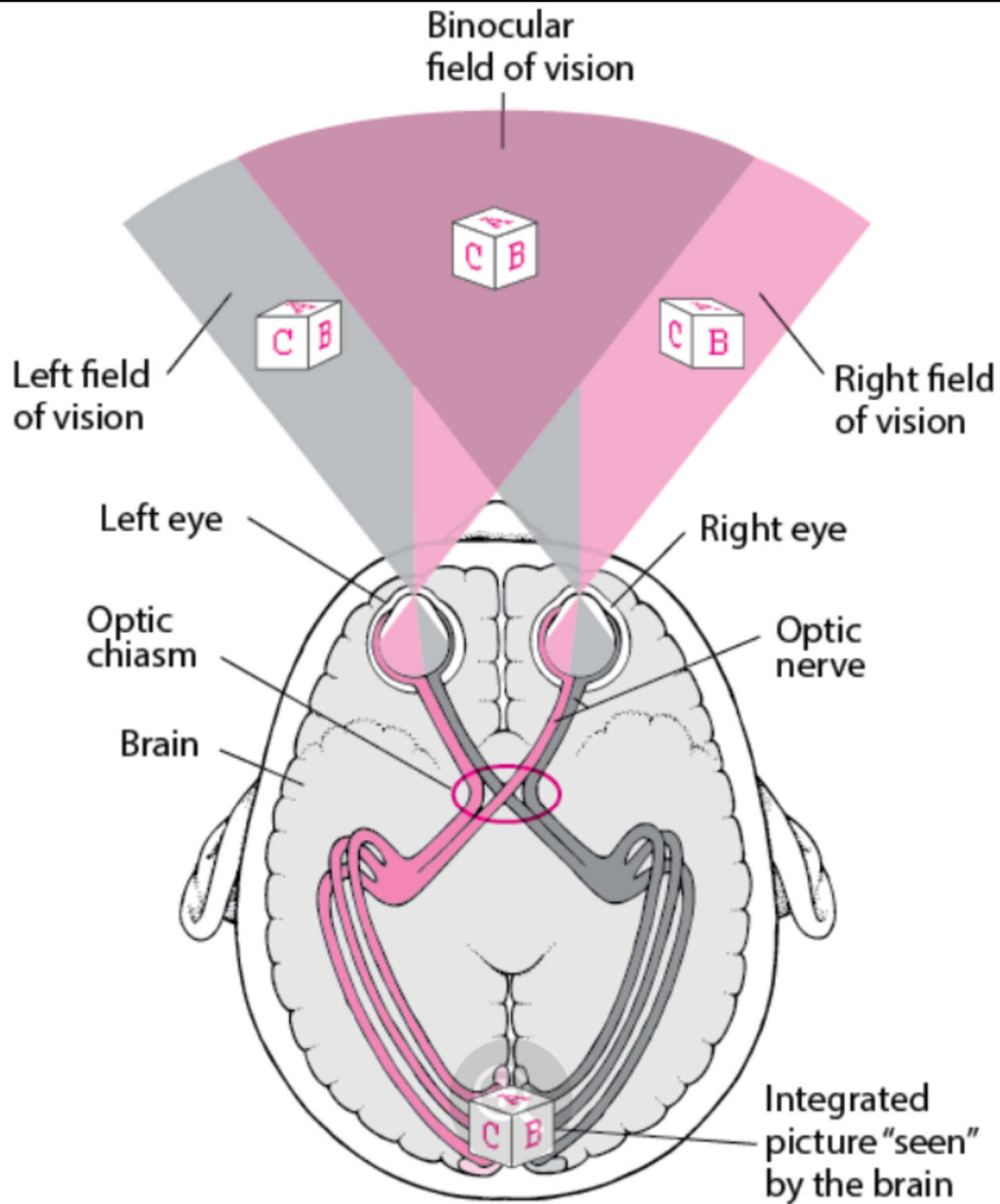

Binocular vision
with two eyeballs

Functions of the human eye

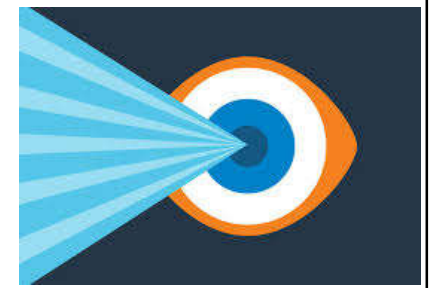

- **Field of view:**

- The angular extent of what can be seen, either with the eye or with an optical instrument
- The field of view of an individual human eye is 95° away from the nose, 75° downward, 60° toward the nose, and 60° upward, allowing humans to have an almost 180-degree forward-facing horizontal field of view

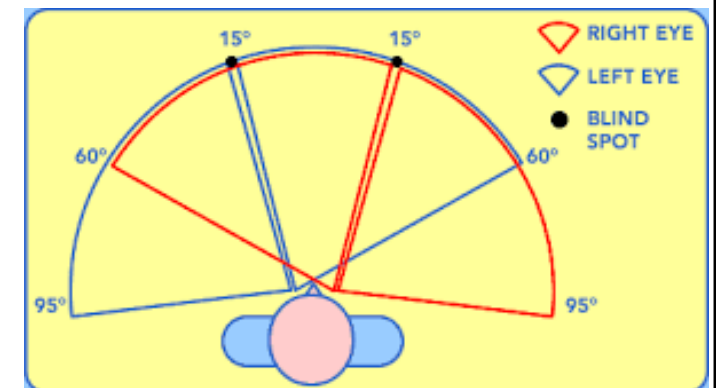
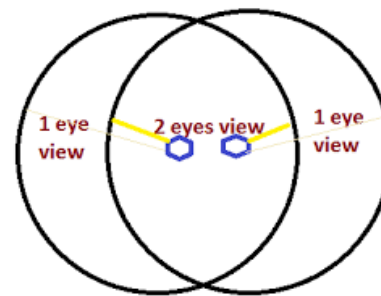

With both eyes, different angles of convergence for objects at different distances help us to see depth

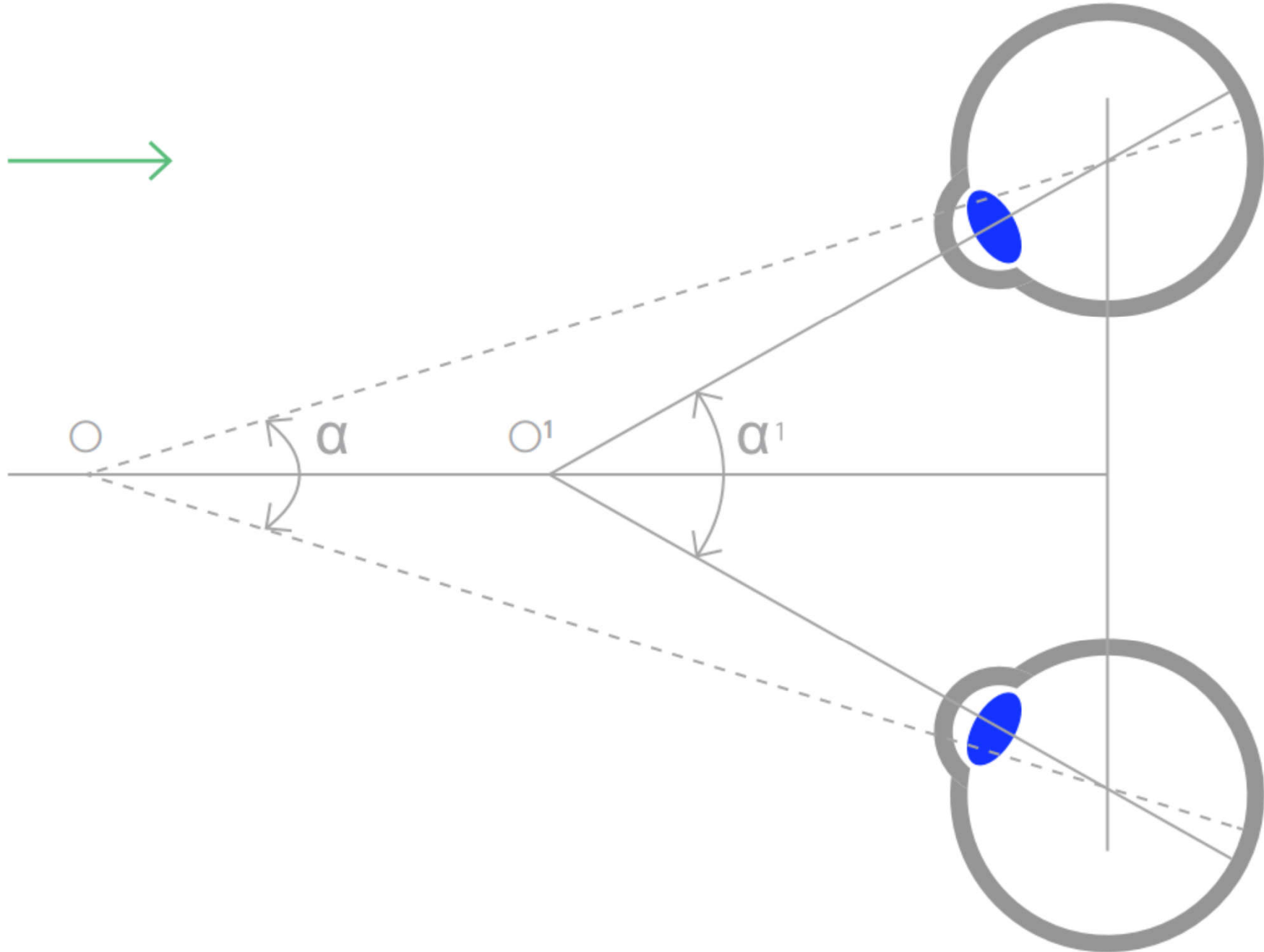

Functions of the human eye

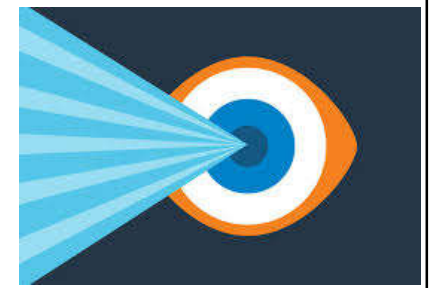

- Common refractive errors in accommodation:
 - Myopia (near-sightedness) 近視 – cannot focus on far objects [Image forms in front of the retina]
 - Hyperopia (far-sightedness) 遠視 – cannot focus on near objects [Image forms behind the retina]
 - Astigmatism 散光 – a difference in horizontal vs. vertical focus due to asymmetric cornea shape [Multiple foci are formed]
 - Presbyopia 老花 – cannot focus on near objects due to loss of lens elasticity in the elderly [Near objects focus behind the retina]

(* See also <http://hyperphysics.phy-astr.gsu.edu/hbase/vision/eyedef.html>)

Cataracts (白内障) in the human visual system

Cataract

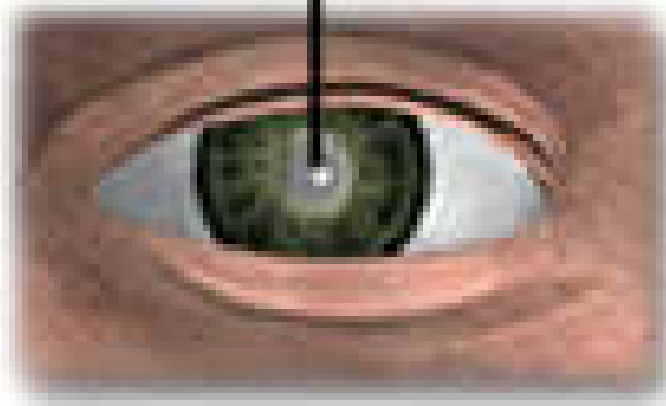

**Lens with
Cataract**

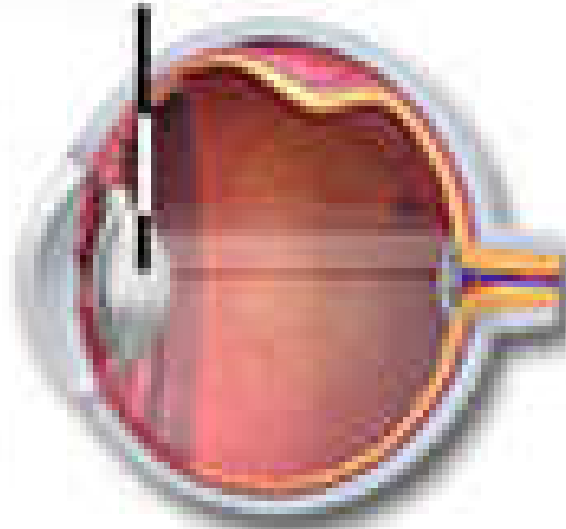

**Image Seen
Through Cataract**

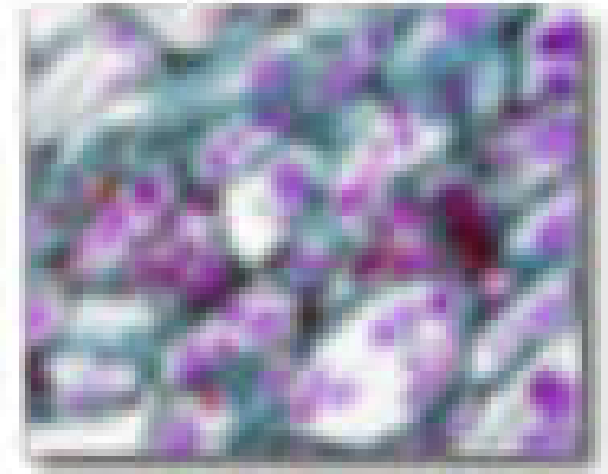

**Eye without
Cataract**

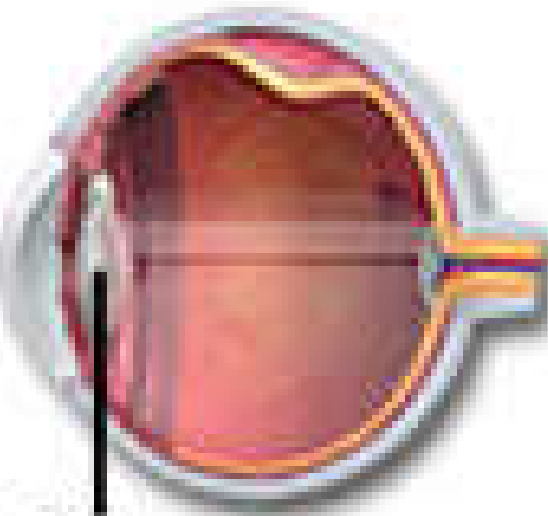

**Clear
Lens**

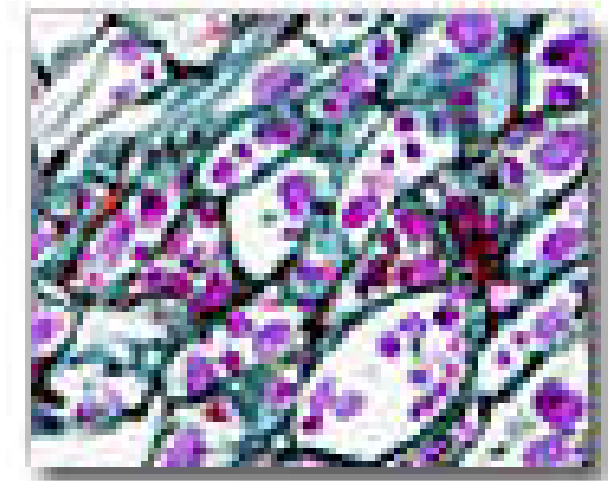

Clear Image

Examples of optical illusions

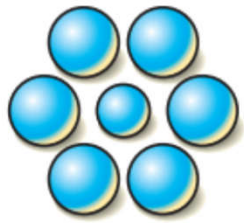

A

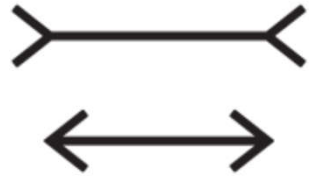

B

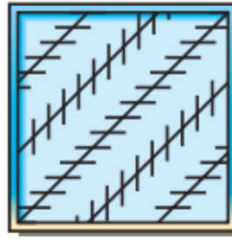

C

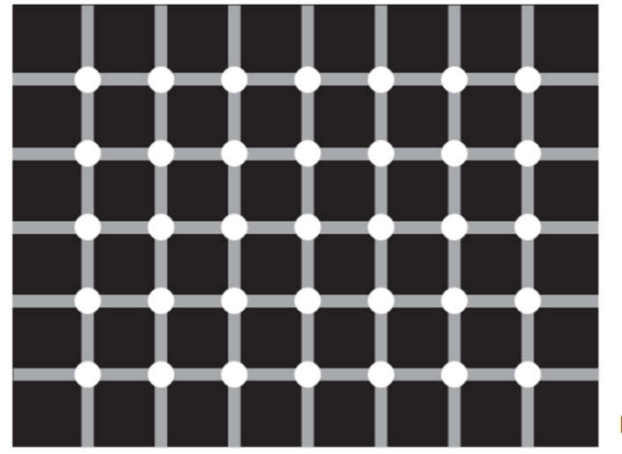

I

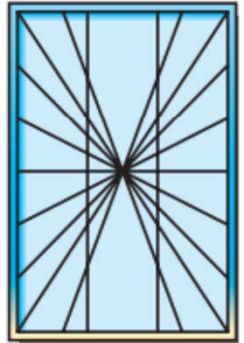

D

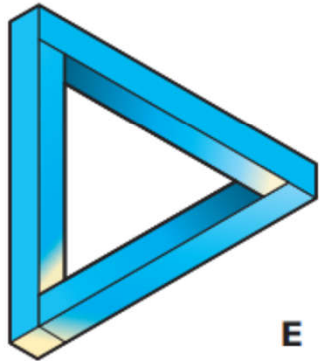

E

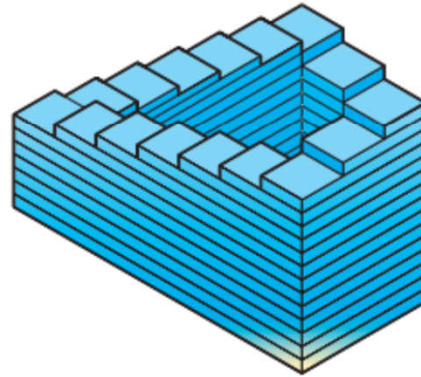

F

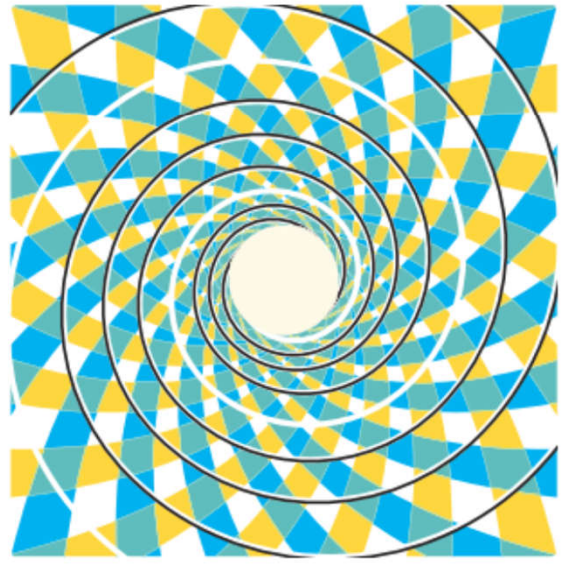
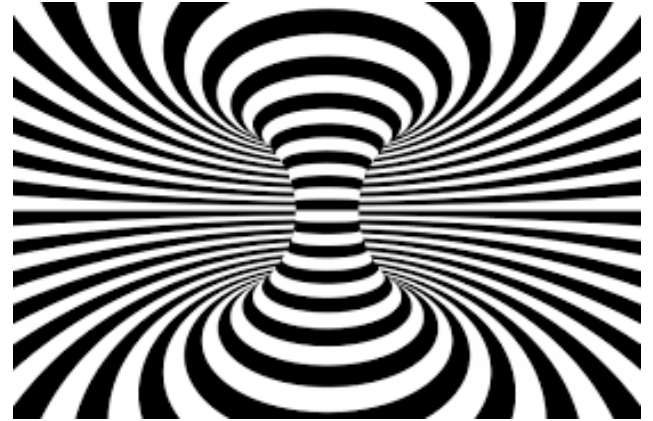

G

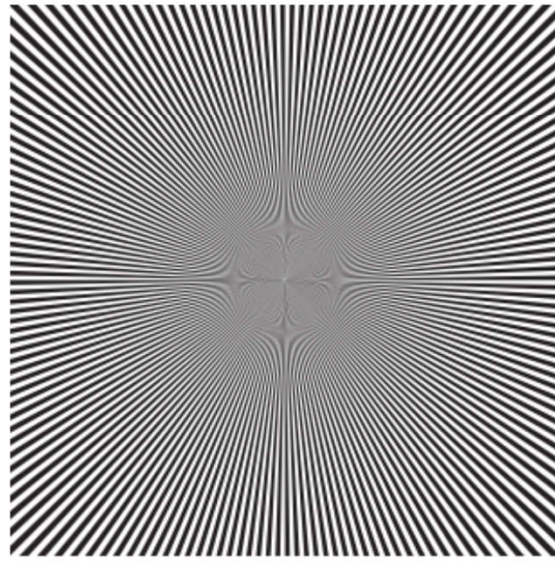

H

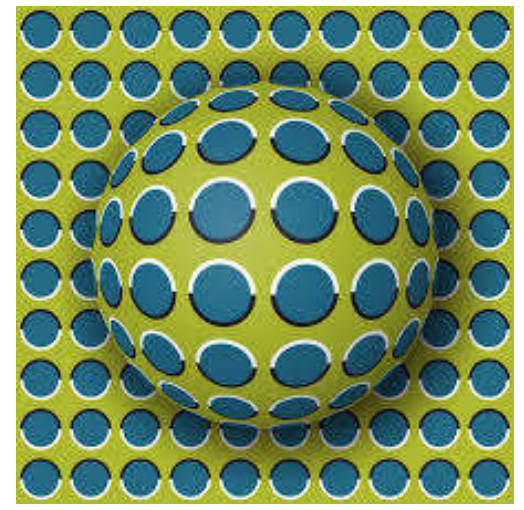

What lighting can do?



- “**Lighting**” is the application of light to **spaces**
 - Have a major impact not only on vision and visual comfort, but perception
 - Can impact satisfaction, visibility, task performance, safety, security, sales, mood and atmosphere, aesthetic judgment and social interaction
 - Also tells a story about the space, such as whether a restaurant is selling fast food or a fine dining experience

Examples of restaurant lighting design (fast food & fine dining)



(Source: <https://www.luminancesys.com/pages/restaurant-lighting-design>)

What lighting can do?



- Lighting design is the process of delivering lighting to spaces
 - It begins with a conversation with the owner about organizational & user needs
 - Who will be using the space?
 - What are their lighting needs?
 - What are the space characteristics?
 - What business goals should the lighting support?
 - What does the owner want the space to communicate?
 - How important is energy efficiency & maintenance?

What lighting can do?



- Major visual effects of lighting
 - 1. Colour perception: For an object to be perceived a certain colour, that colour must be present both in the object & the content of the light striking it
 - 2. Focus: The human eye is naturally attracted to the brightest area in the field of view
 - 3. Space perception: The pattern of light in a space can stimulate a psychological response
 - 4. Modelling: The contrast of light & shadow can reveal texture & add depth to objects & surfaces

Lighting effect and psychological impact

Psychological impact	Lighting effect	Light distribution
TENSE	Intense direct light from above	Non-uniform
RELAXED	Lower overhead lighting with some lighting at room perimeter, warm color tones	Non-uniform
WORK/VISUAL CLARITY	Bright light on workplane with less light at the perimeter, wall lighting, cooler color tones	Uniform
SPACIOUSNESS	Bright light with lighting on walls and possibly ceiling	Uniform
PRIVACY/INTIMACY	Low light level at activity space with a little perimeter lighting and dark areas in rest of space	Non-uniform

Modelling to reveal texture & add depth to faces, objects & surface



What lighting can do?



- Visual performance
 - Major aspect: Provide adequate lighting for people to carry out their visual tasks
 - Visibility is defined by our ability to detect objects or signs of given dimensions, at given distances & with given contrasts with the background
 - Visual performance is defined by the speed & accuracy of performing a visual task
 - Visual performance & consumption of electricity for lighting should be in balance in order to increase energy efficiency

Relative visual performance as a function of background luminance and target contrast

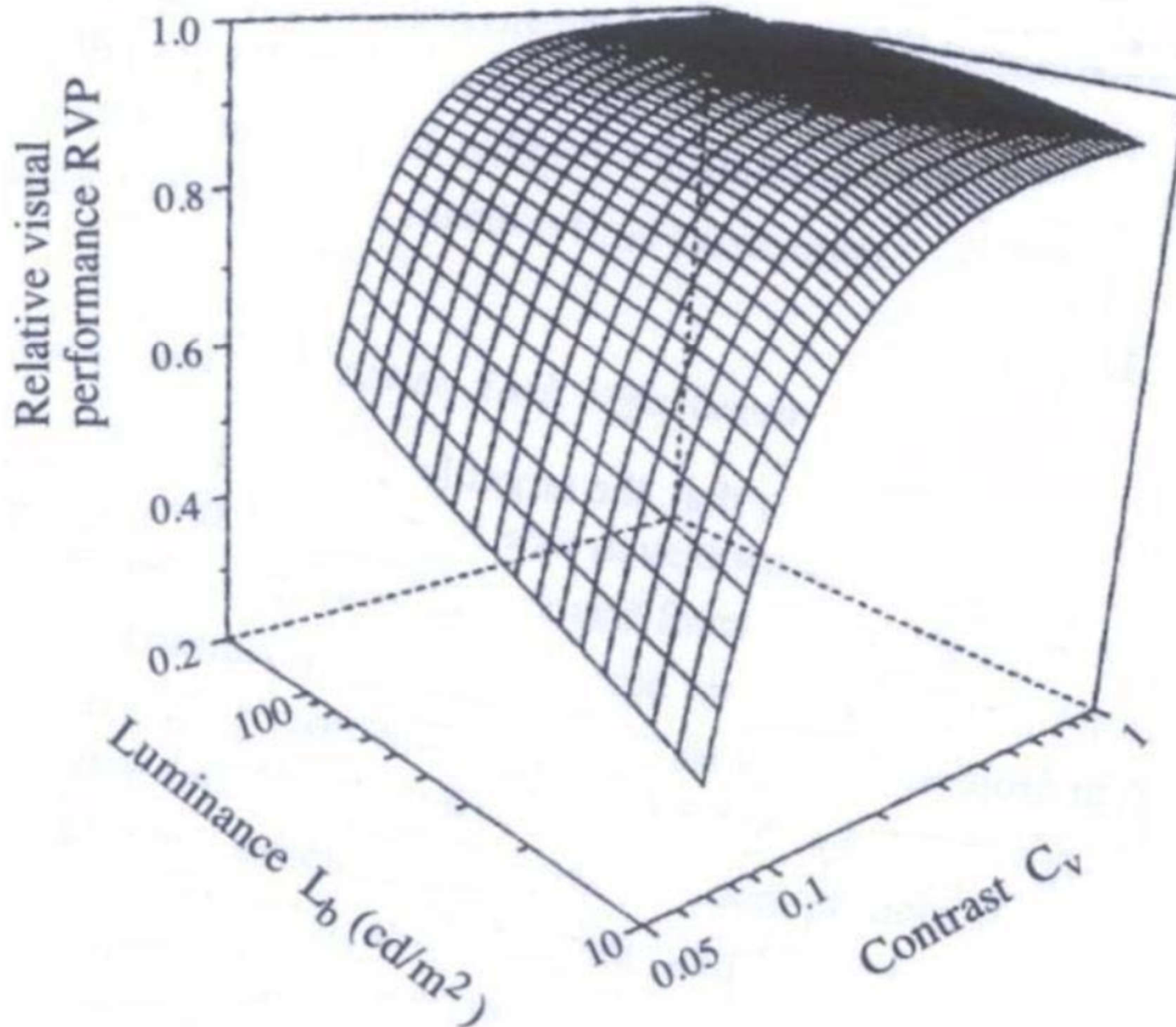

(Source: Halonen L., 1993. *Effects of Lighting and Task Parameters on Visual Acuity and Performance*, Thesis for the degree of Doctor of Technology, Helsinki University of Technology, Espoo.)

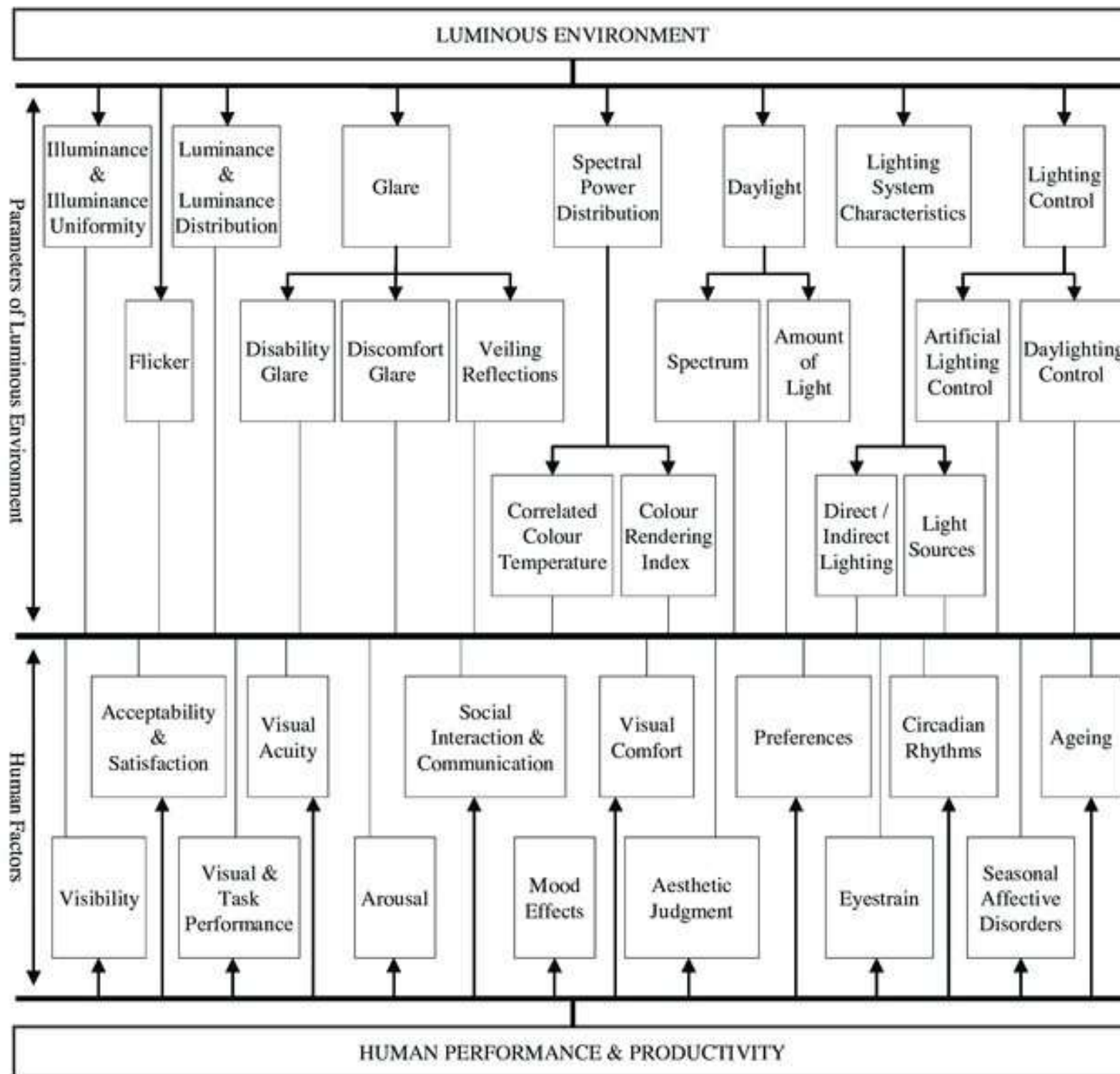

Luminous environment and human performance

What lighting can do?



- Visual comfort

- It is highly dependent on the application



- Lighting that is considered comfortable in an entertainment setting may be disliked and regarded as uncomfortable in a working space

- Pleasantness of the visual environment and its adaptation to the type of room & activity

- Many physical & physiological factors can influence the perception of lighting quality

- Also long term effects of light on our health

Considerations for visual comfort

To be able to fully describe light, one needs to discuss its many aspects:

its source,

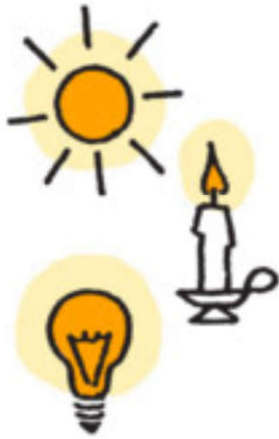

its distribution,



its tone and color,

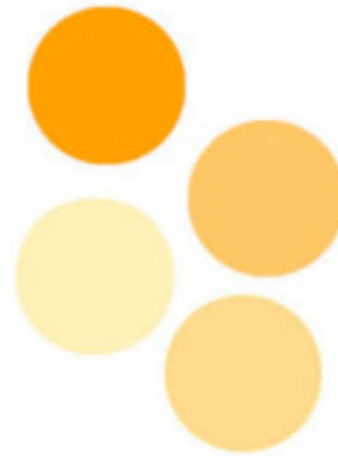

its intensity...



Being able to control light levels is also key to visual comfort: both too little and too much light can be a source of discomfort.



Sharp contrast or major changes in light levels can cause stress and fatigue, as the human eye is permanently adapting to light levels.



The socio-psychological aspects of visual comfort

The **SOCIO PSYCHOLOGICAL** aspect of visual comfort



Light has a profound effect on the way we feel and experience time and space, both consciously and unconsciously.



Our personal history and culture also shapes the way we appreciate light and visual environments.



Extreme variations in preferred range of illuminances exist depending on age and culture.



But whatever the nationality, age or social category, light directly influences the mood and health of all humans.

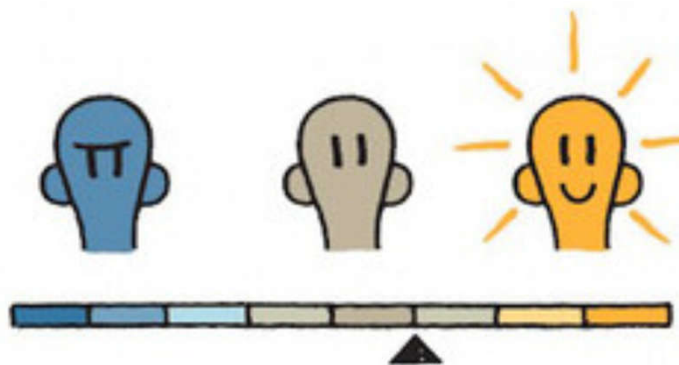

Non-visual effects of light play an important role in this respect. Their discovery is fairly recent and they remain the subject of active scientific research.



What lighting can do?



- Factors affecting visual comfort
 - Illuminance level
 - Uniformity & light distribution in a space
 - Glare & veiling reflections
 - Formation of shadows in the space
 - Flicker (fluctuation of light emitted by light source)
 - Light colour characteristics
- Psychological aspects of light
 - Light scenes judged w/ references & expectations

Colour mood chart for psychology emotion



Lighting quality



- 1. Lighting level
 - To support visual performance for the tasks
- 2. Luminance contrast
 - Luminance distribution within the field of view
- 3. Glare restriction
 - Brightness levels within the visual field
- 4. Spatial distribution of the light
 - Determines the pattern of illuminances that will be created
- 5. Colour and colour rendering
 - Colour composition of the lighting & appearance

The quality of the lighting depends on a number of factors

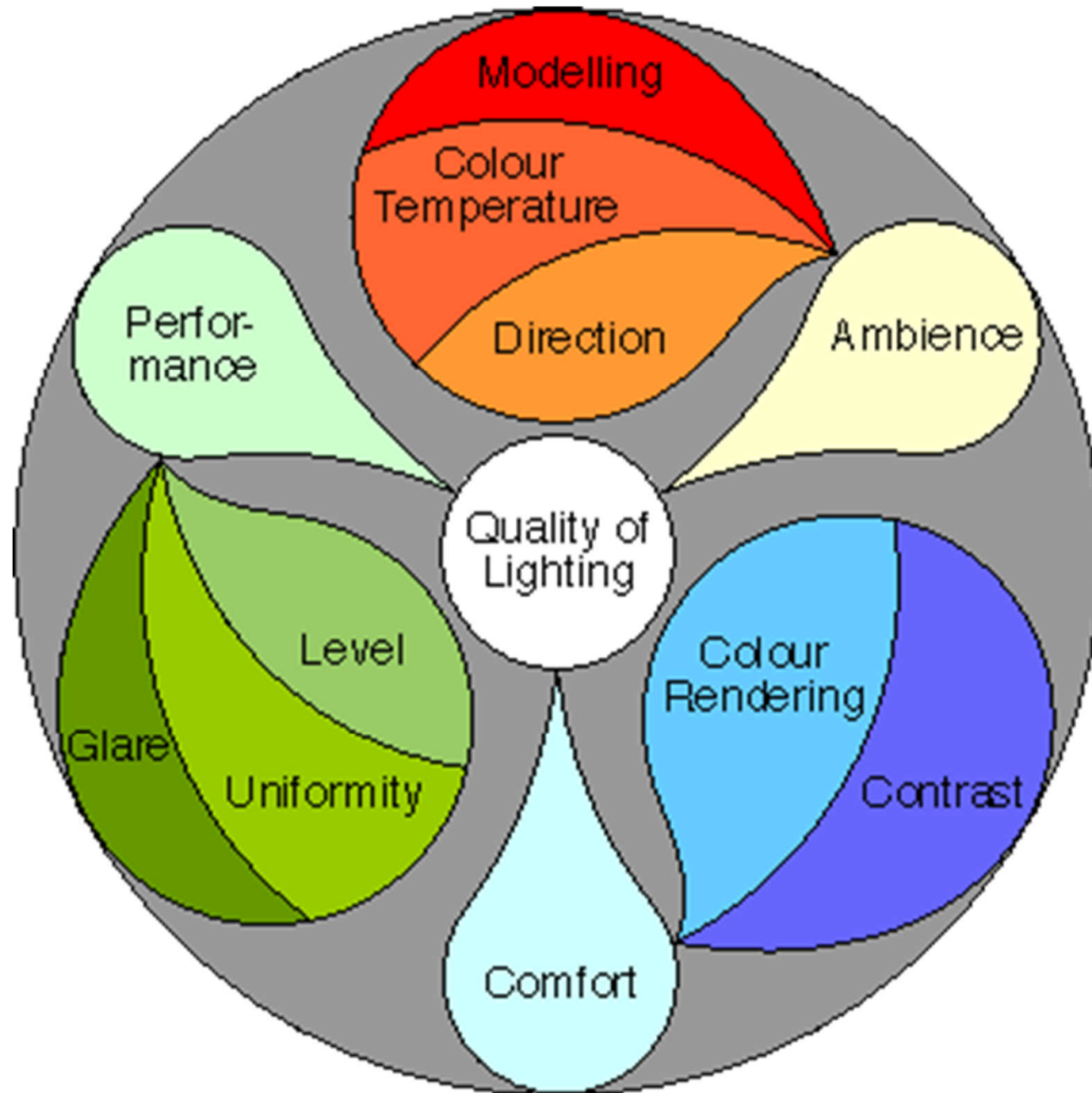

Visual and non-visual effects of light

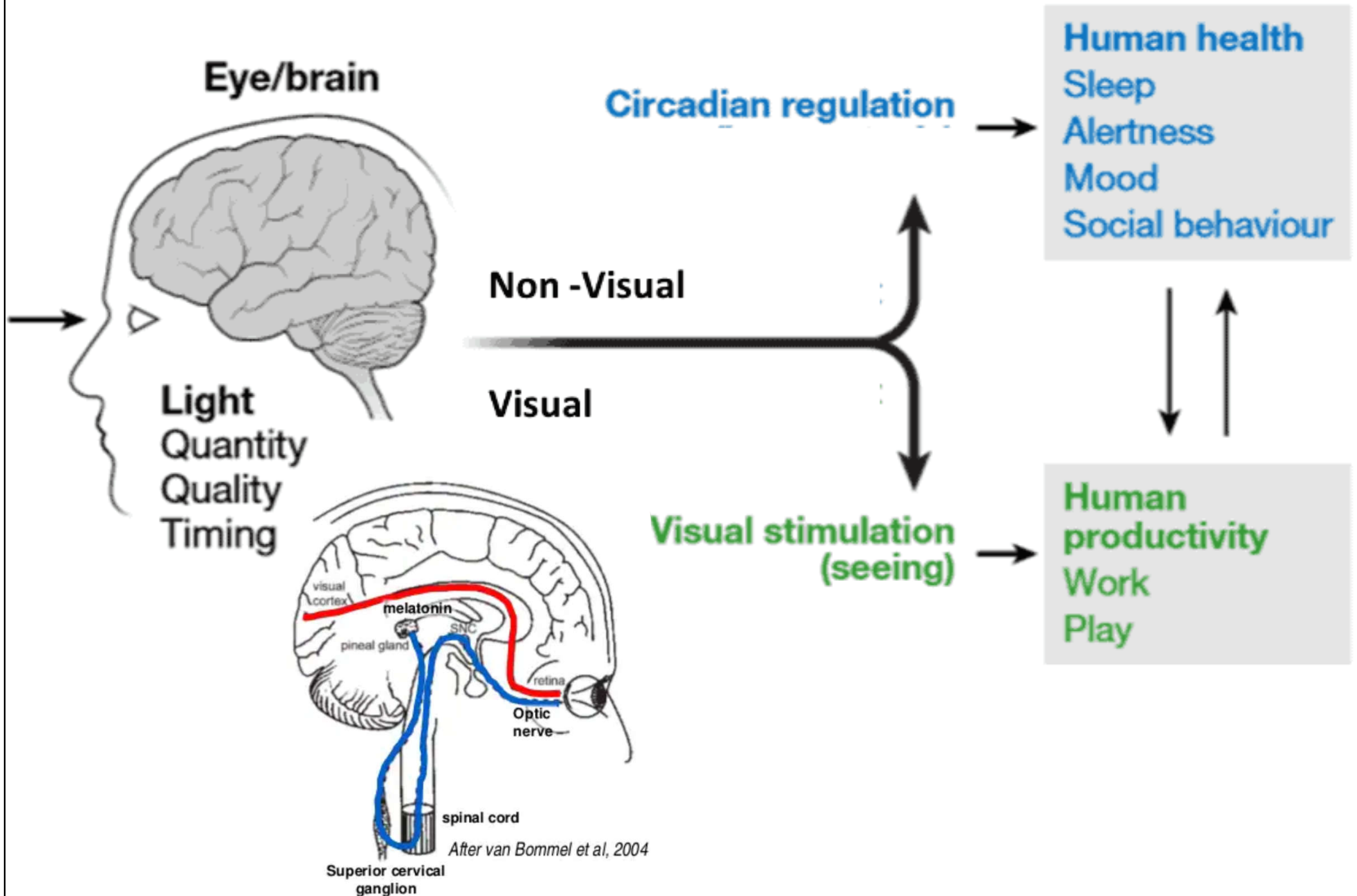

Lighting quality



- Non-visual effect of light
 - Impact of lighting on human health, well-being & visual performance
 - Physiological mechanisms of the visual & non-visual effects of light on humans
 - Biological bases of photoreception & non-image-forming vision at the cellular level
- Circadian lighting & human centric lighting
 - Visual, emotional & biological effects

Light has both visual and non-visual responses acting through the different retinal photoreceptors and tracts in the nervous system

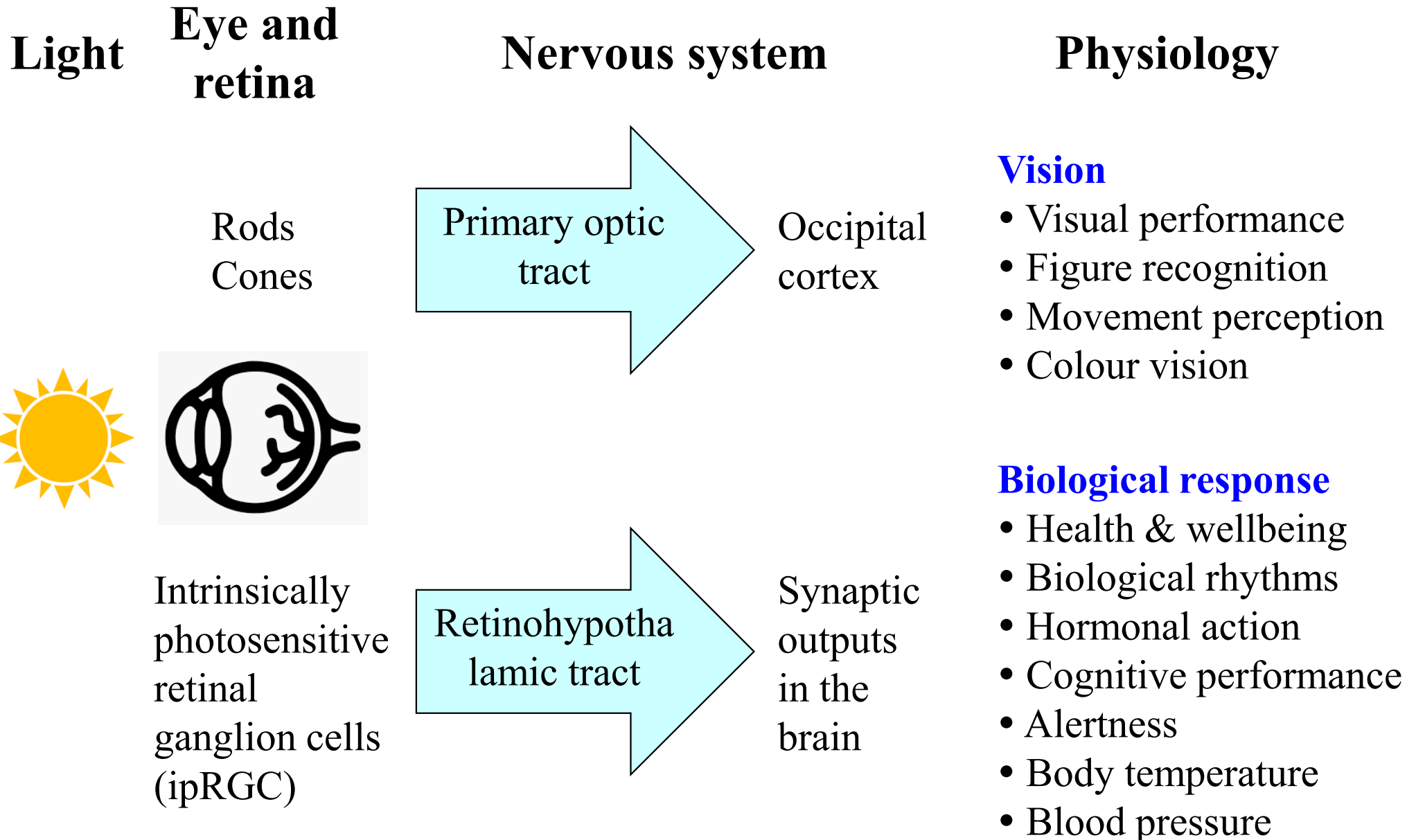

Three aspects of non-visual effects of light*

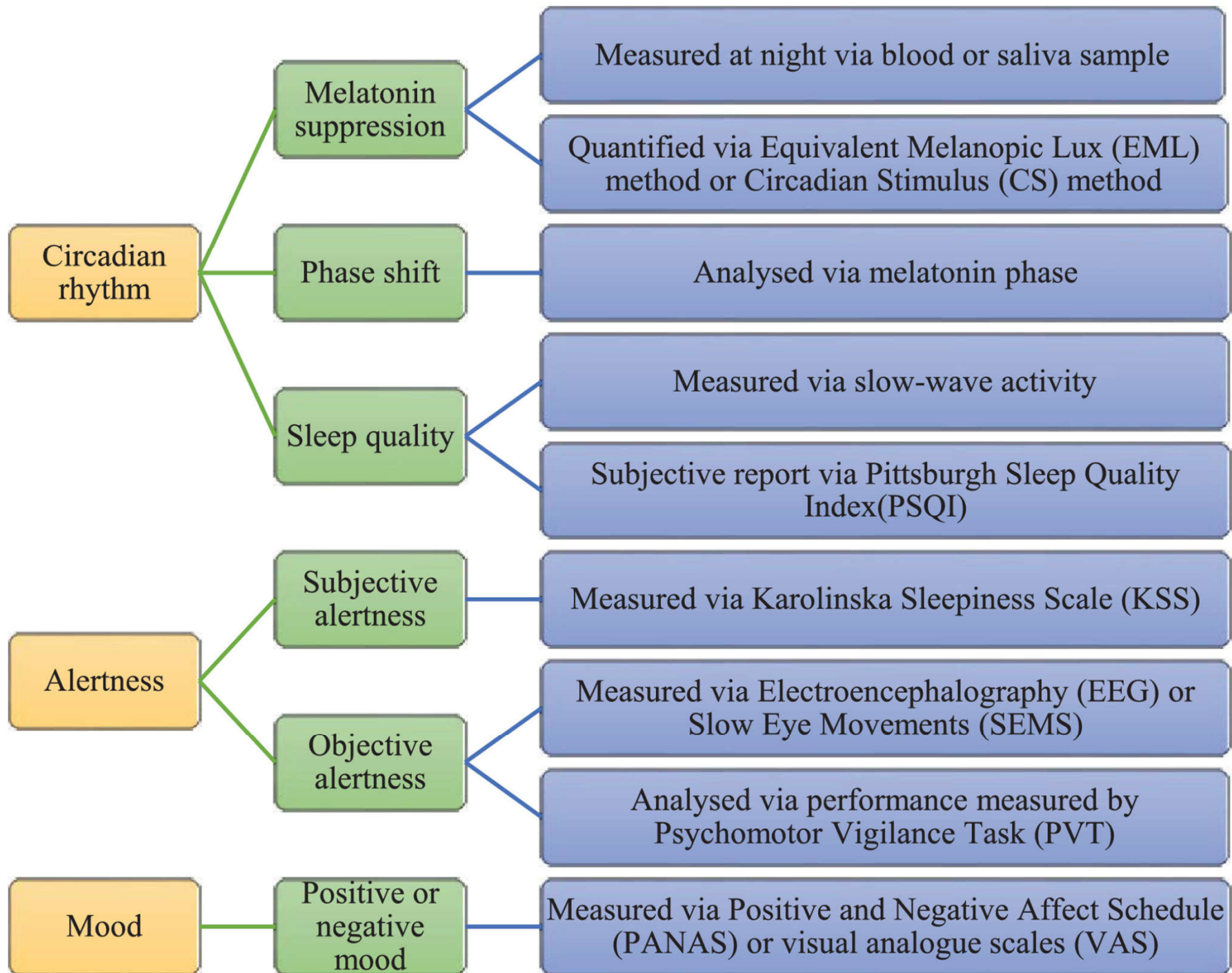

(*Xiao X., Cai H. & Li X., 2021. Non-visual effects of indoor light environment on humans: A review, *Physiology & Behavior*, 228: 113195.)

Human Centric Lighting (HCL) based on the biological effects of light

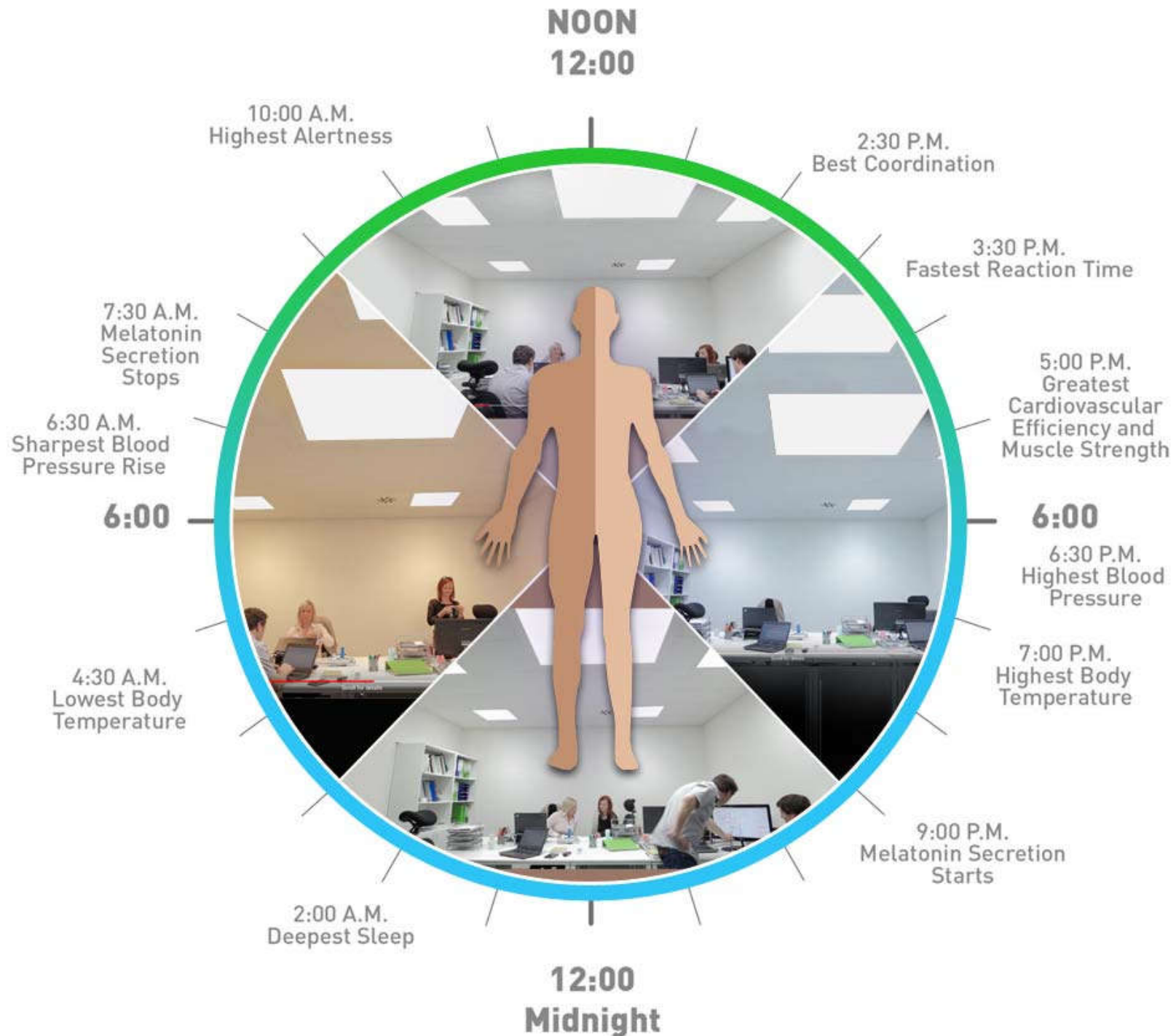

Design of different types of human centric lighting (HCL)



Circadian Lighting

The light is not static but changes throughout the day in terms of its colour and intensity. An installation of this type promotes the necessary sleep-wake rhythm.



Energising Lighting

Light with a high blue component (or cold white) and which energises the body, increasing performance as well as the ability to concentrate.



Relaxing Lighting

Light with a warm white tonality (with a high red component) has a relaxing effect on our body.



Emotive Lighting

Light that adapts to the chromatic intensity and tonality, depending on the emotional needs of the individual.

Entertainment lighting to synchronise with movies, music & games



(Source: <https://www.philips-hue.com/en-hk/explore-hue/philips-hue-benefits>)



Further Reading

- Lighting theory essentials (Philips Lighting/Signify)
<https://www.signify.com/global/lighting-academy/browser/course/lighting-theory-essentials>
 - Visual process of the eye (3:57)
<https://youtu.be/Wx1bgW3eFEk>
 - Lighting vision (4:02) https://youtu.be/880FaL_9QJY
 - Light and health (4:56) <https://youtu.be/GbHGRRMv7rDE>
- Light@Work, by OSRAM [PDF]
 - http://ibse.hk/IBTM6010J/Light_At_Work.pdf