

MEBS6006 Environmental Services I

<http://www.hku.hk/bse/MEBS6006/>

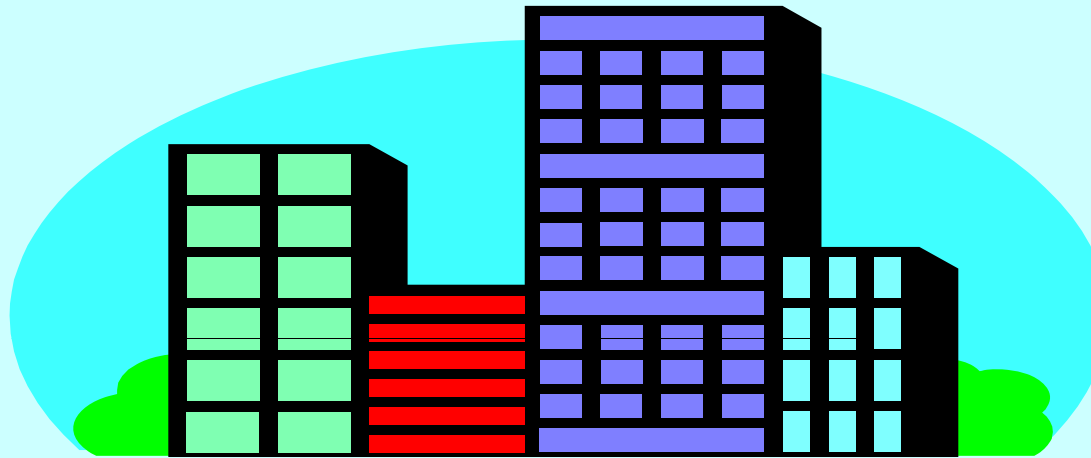

Introduction



Dr. Sam C M Hui

Department of Mechanical Engineering

The University of Hong Kong

E-mail: cmhui@hku.hk

Sep 2009

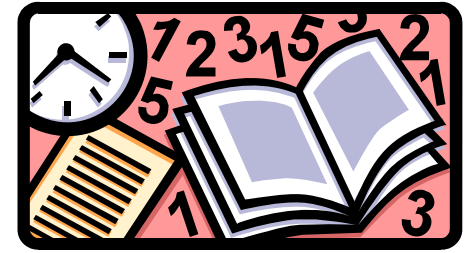

Background

- MEBS6006 Environmental Services I
 - Educational Objectives
 - To enable students to understand the basic principles of design and operation of heating, ventilating, air-conditioning and refrigerating (HVAC&R) systems for environmental control of buildings
 - To enable students to design and select proper HVAC&R systems to serve the desired purpose

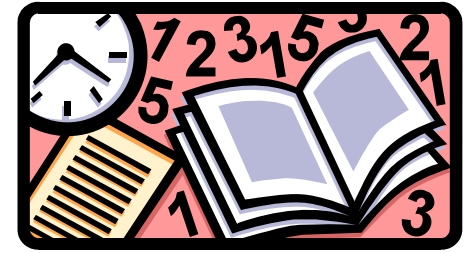

Background

- MEBS6006 Environmental Services I
 - Learning Outcomes:
 - To explain the fundamental principles of HVAC&R systems for environmental control of buildings.
 - To develop skills for design and selection of HVAC&R systems.
 - Assessment: 100% by examination

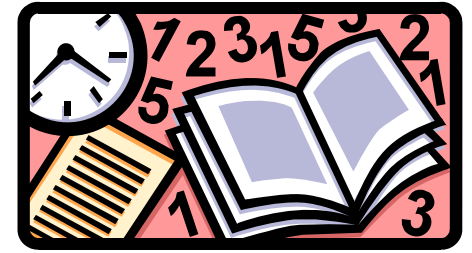

Background

- These two courses are related
 - MEBS6006 Environmental services I
 - Basic principles of HVACR
 - Practical design skills
 - MEBS6008 Environmental services II
 - System characteristics and operation
 - Analysis and design strategies
- If possible, should study both

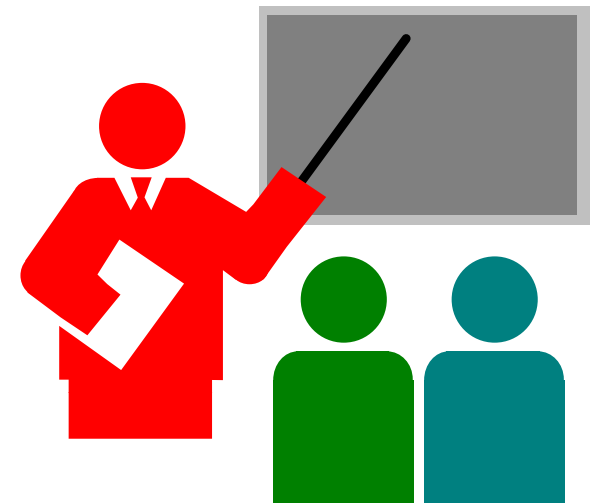

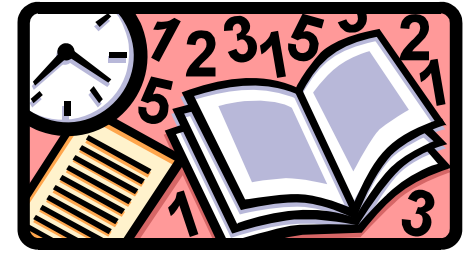

Background

- Study topics of MEBS6006:
 - Introduction
 - Advanced psychrometry
 - Thermal comfort
 - Load estimation
 - Energy calculations
 - Cooling system
 - Heating and ventilation system
 - Air side system
 - Water side system
 - Refrigeration

Dr. Sam C M Hui

Dr. Benjamin P L Ho

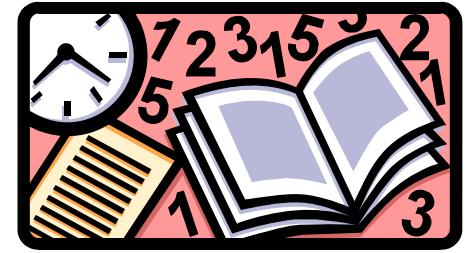

Background

- Assumptions
 - You have basic knowledge of thermodynamics and fluid mechanics
 - You are interested in developing your knowledge and skills in HVAC
- Focus of this course
 - From basic principles to intermittent level of HVAC design skills
 - Main focus on cooling design and air conditioning

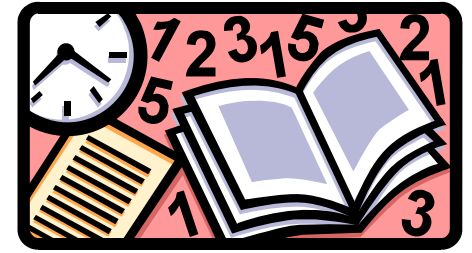

Background

- Your experience and expectation
 - Raise your hand if you have:
 - Very little knowledge of HVAC
 - Some knowledge of HVAC (e.g. attend courses before)
 - Certain design experience of HVAC (1-3 years)
 - Good design experience of HVAC (4-8 years)
 - Excellent knowledge & experience (> 10 years)
 - What do you expect from this course?
 - Knowledge? Practical design skills?

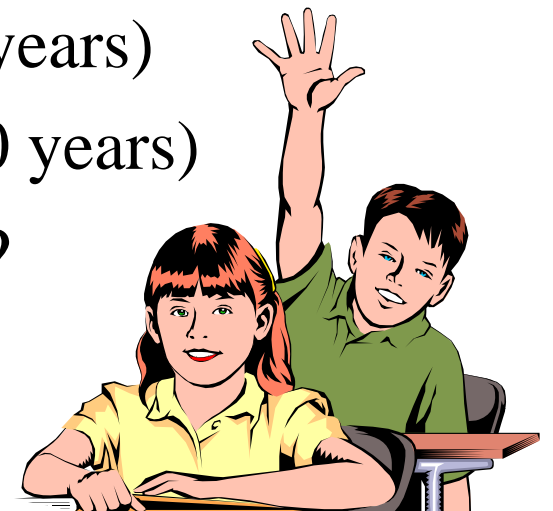

What is Environmental Services?



Environmental Services

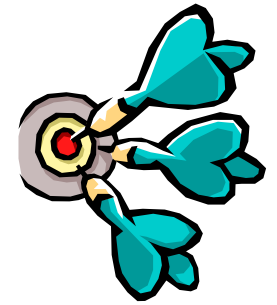

- They are the engineering systems that help to control and maintain the conditions of indoor built environment
- They are also known as
 - Environmental control systems (ECS)
 - Heating, ventilating, air-conditioning and refrigerating (HVAC&R) systems
 - Heating, ventilating and air-conditioning (HVAC)
 - Mechanical ventilating and air-conditioning (MVAC)
 - Air conditioning and refrigeration (AC&R)

Environmental Services

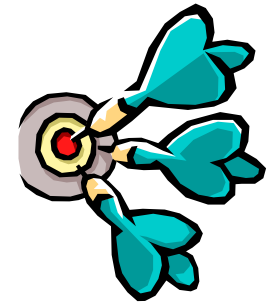

- Importance of HVAC for environmental control in buildings
 - Affect occupant satisfaction, productivity, health and safety
 - Contribute to effective building performance
 - Often form a major part of building construction costs and running costs
 - Affect energy consumption & environmental performance of a building

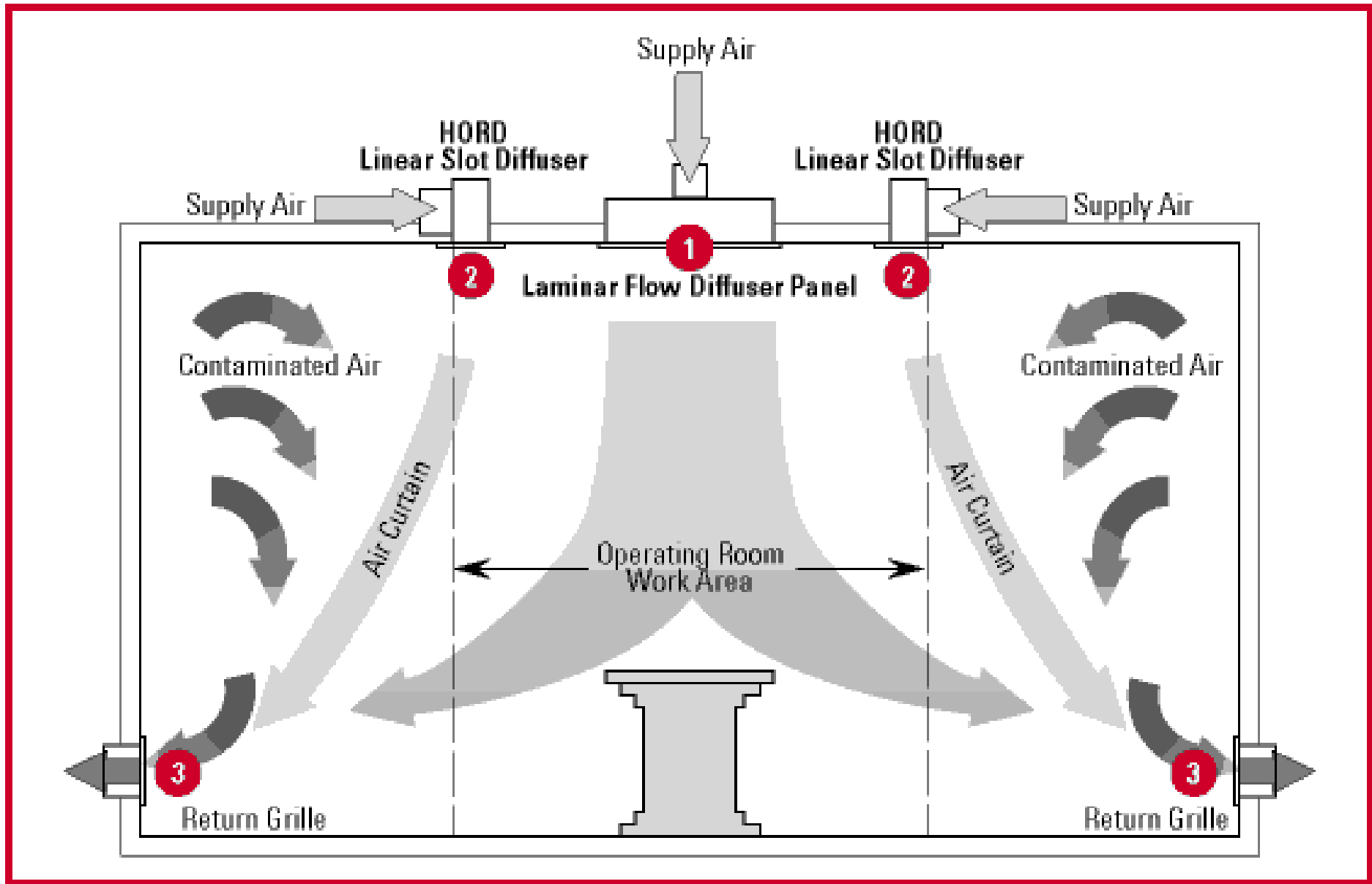

Hospital operating theatre (laminar flow with air curtains)

(Source: <http://www.price-hvac.com>)

Environmental Services

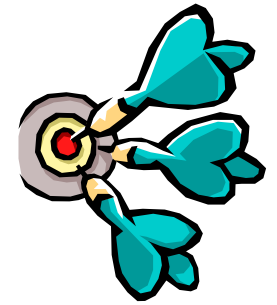

- Practical design strategy: integrated approach
 - AIM to meet the requirements of the people & processes without being excessive & wasteful
 - Energy efficiency, technically & economically sound
 - LINK with the design of building fabric (architecture) to maximise passive design potential
 - BASED on clear understanding of the building, client and end-user needs
 - FOLLOWED by effective commissioning, handover and building management

Environmental Services

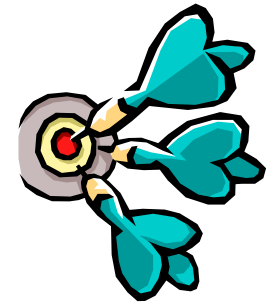

- Establish key performance requirements, e.g.
 - Demands of building occupants & activities
 - Reliability, adaptability & flexibility
 - Maintenance requirements
 - Control quality & complexity
 - Aesthetics, time constraints & security
 - Investment criteria & whole life cycle costs
 - Energy/environmental targets
 - Indoor environmental standards

Environmental Services

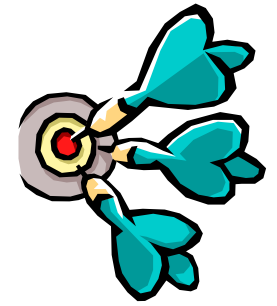

- Interactions
 - Building fabric (architectural design)
 - Site orientation & conditions
 - Built form, shading, window performance, thermal mass
 - Thermal insulation, reducing infiltration/air leakage
 - Building services elements, e.g.
 - Lighting system & daylighting
 - Small power or equipment loads
 - Occupants' behaviour (human factors)
 - How users behave and react

Sources of Cooling Load

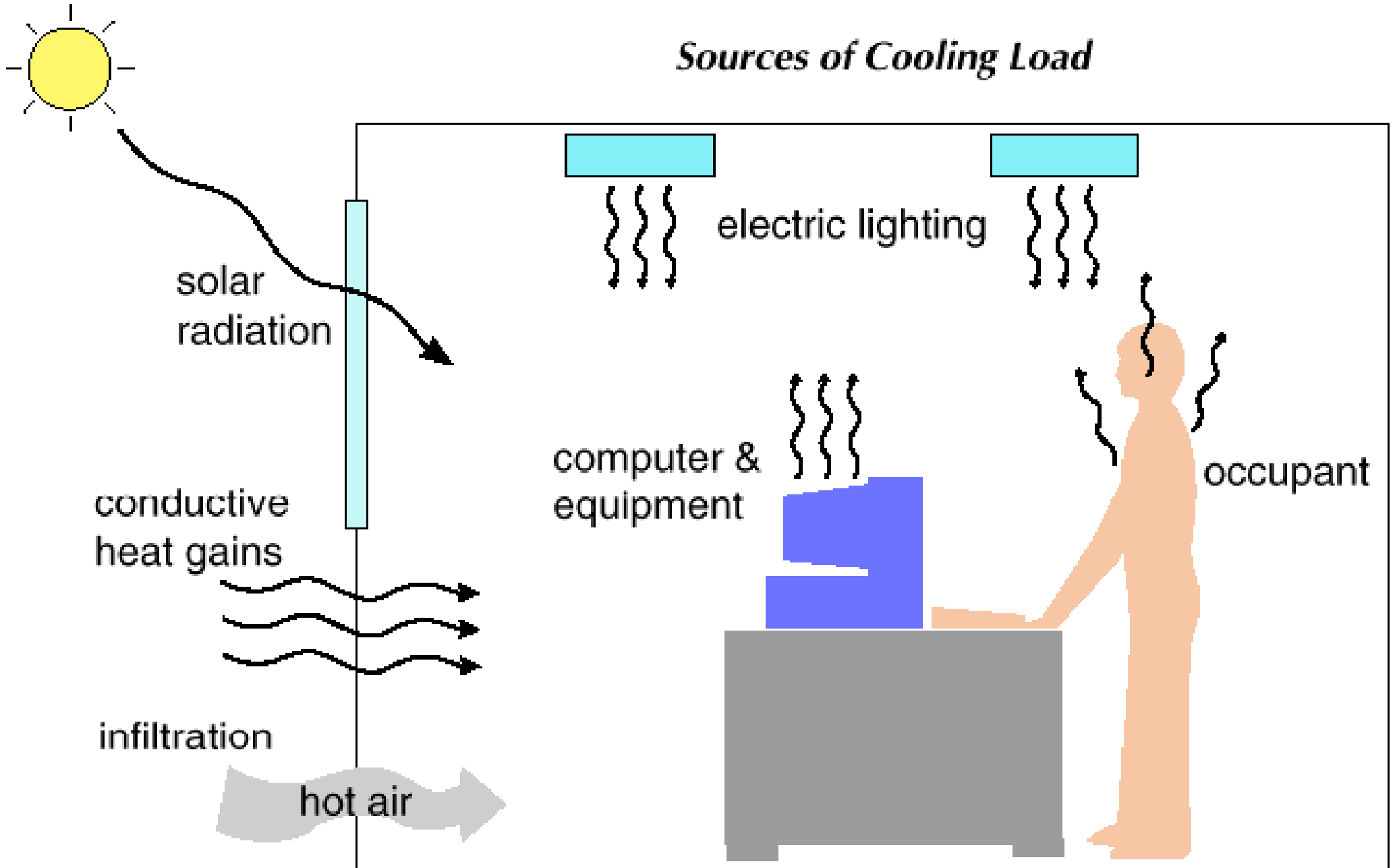

Environmental Services

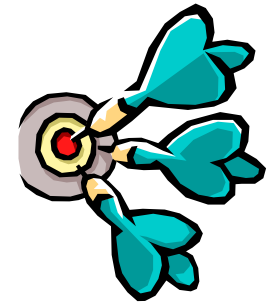

- Understand the purpose of the design
 - To provide adequate indoor air quality by removing and/or diluting indoor pollutants
 - To provide adequate ventilation for processes
 - To remove heat & maintain thermal comfort
 - To control humidity & prevent condensation
- Understand the climate
 - Summer: cooling design & dehumidification
 - Winter: heating design

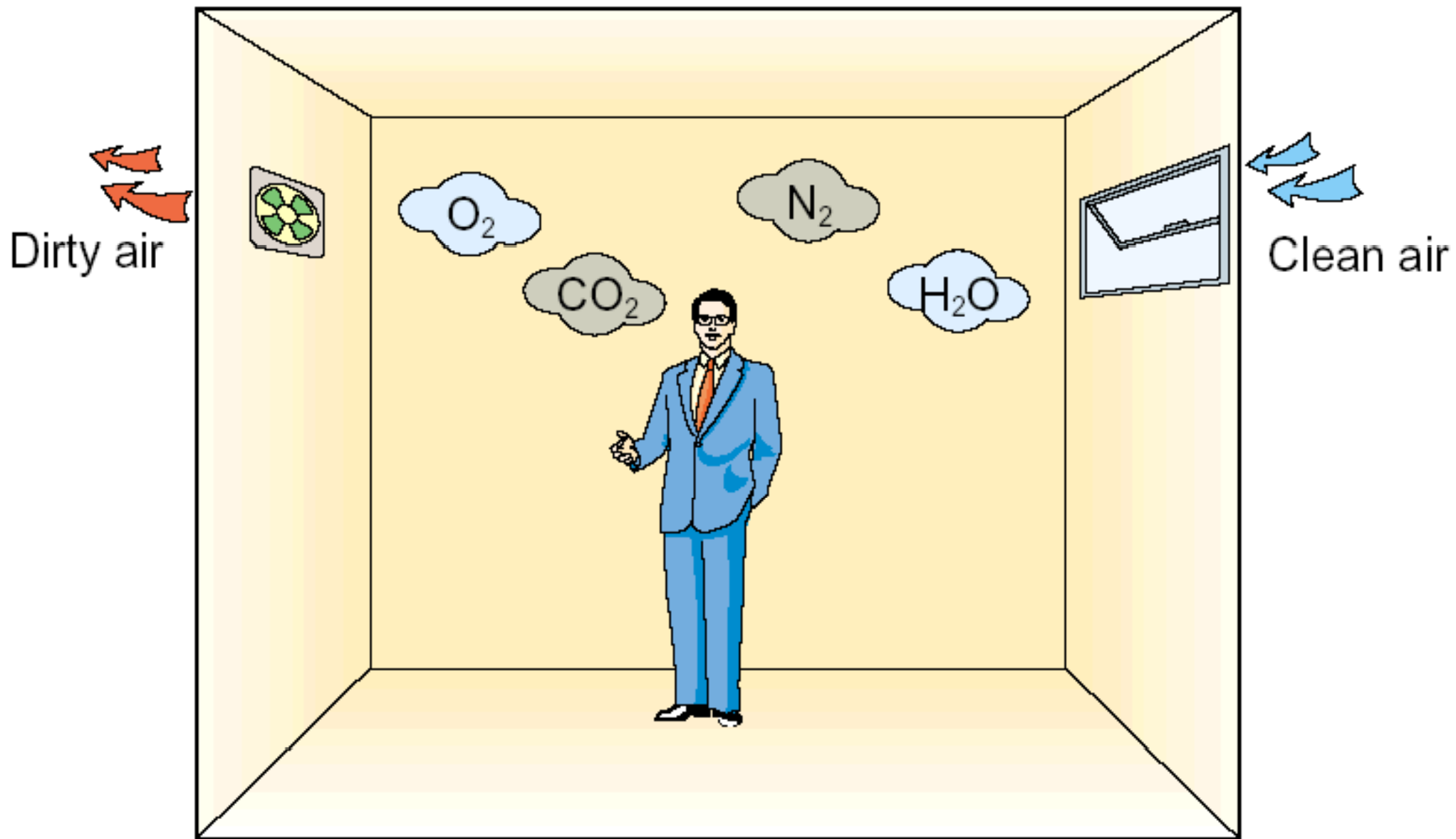

(Source: www.iaq.hk)

Environmental Services

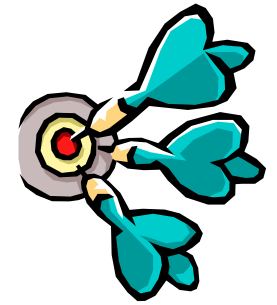

- Common ventilation strategies
 - Natural ventilation
 - Mechanical ventilation
 - Comfort cooling
 - Air conditioning (full control of temp./humidity)
 - Mixed mode or hybrid systems
- Further information:
 - *CIBSE Guide B2: Ventilation and Air Conditioning, Chapter 2*

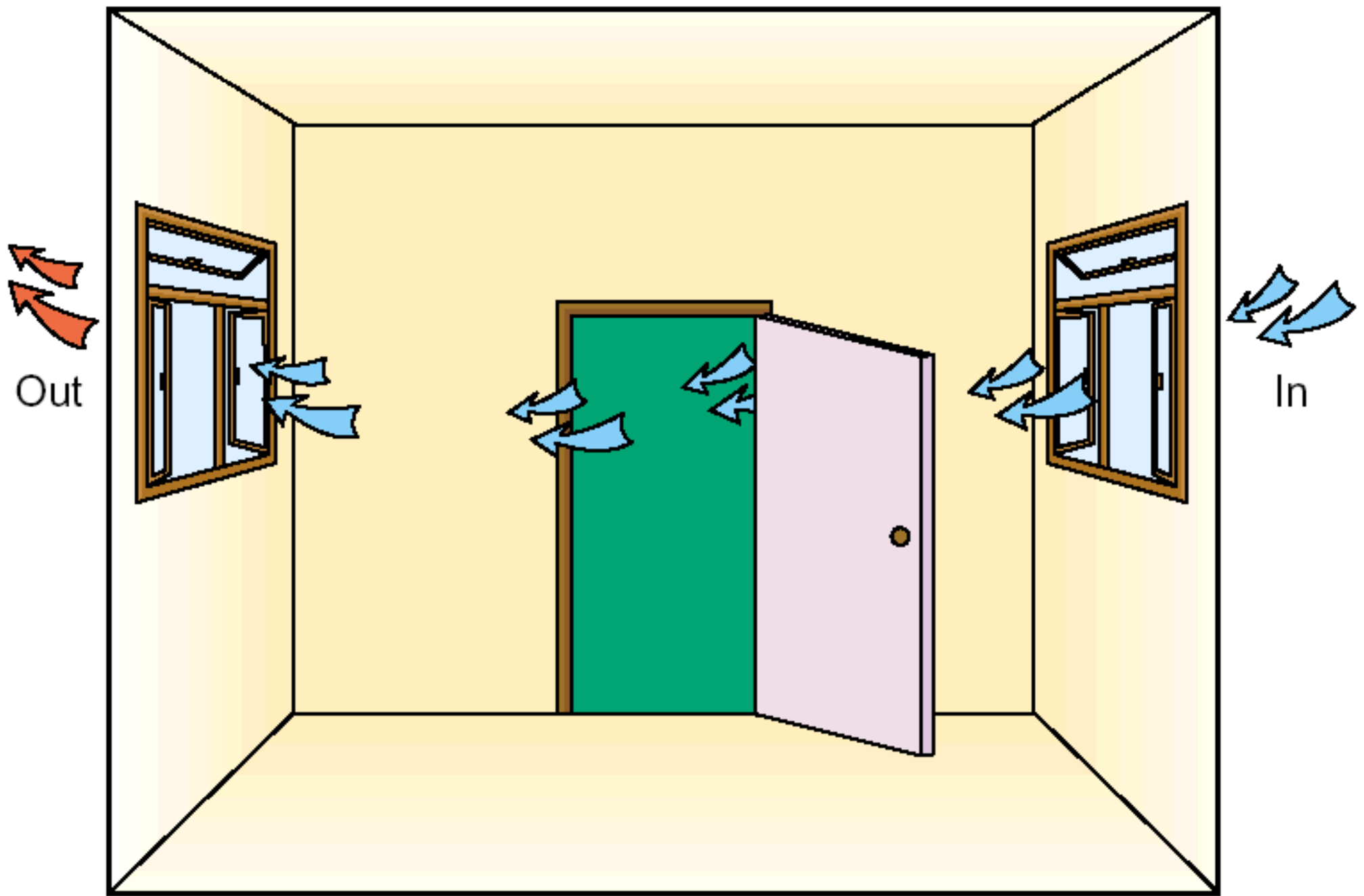

Cross ventilation

(Source: www.iaq.hk)



(Source: www.iaq.hk)

典型空調系統

Typical Air-conditioning Process

What is this A/C system called?

冷卻盤管具冷卻及抽濕功效
Cooling Coil for Cooling & Dehumidification

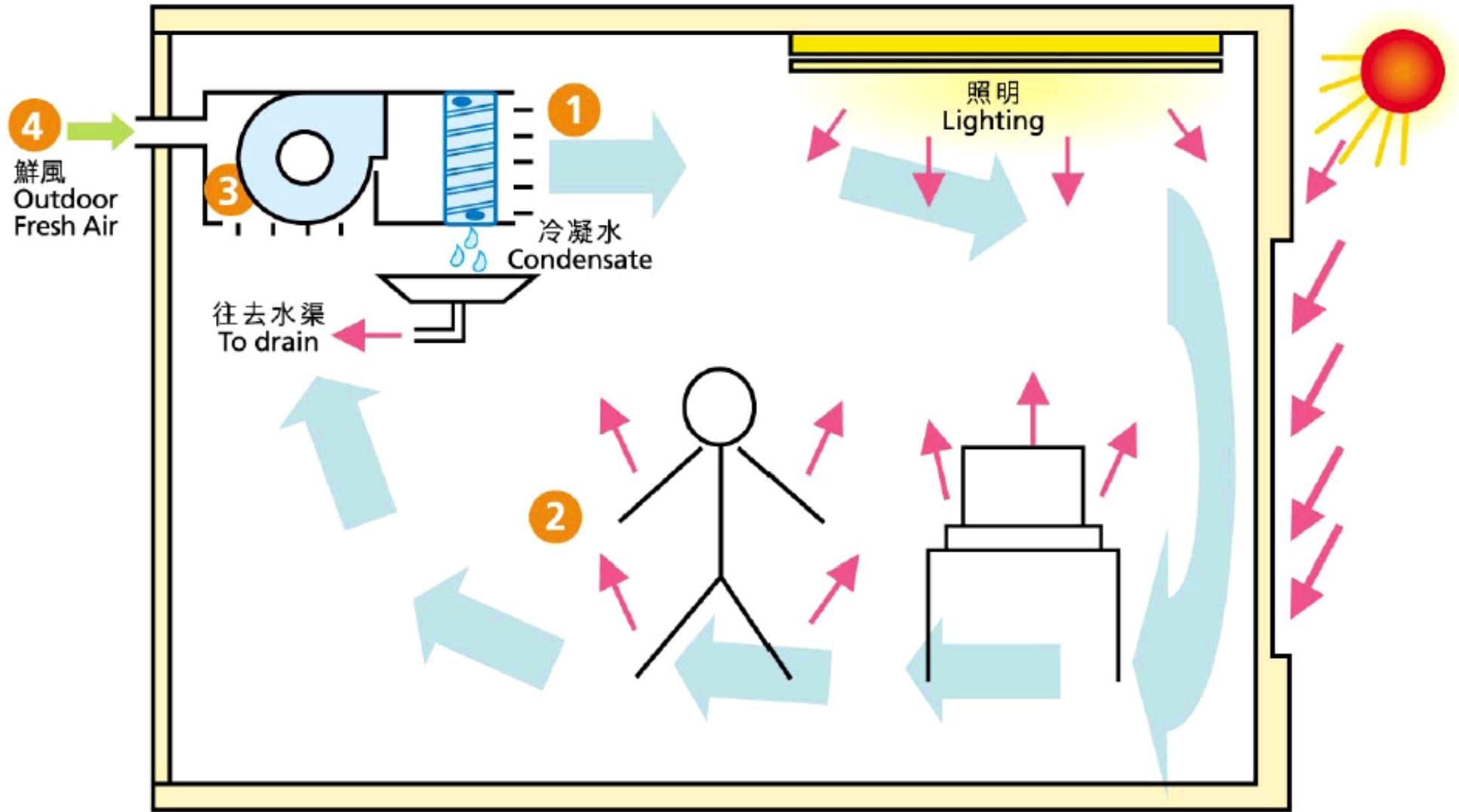

(Source: EnergyWitts newsletter, EMSD)

Refrigerant cycle

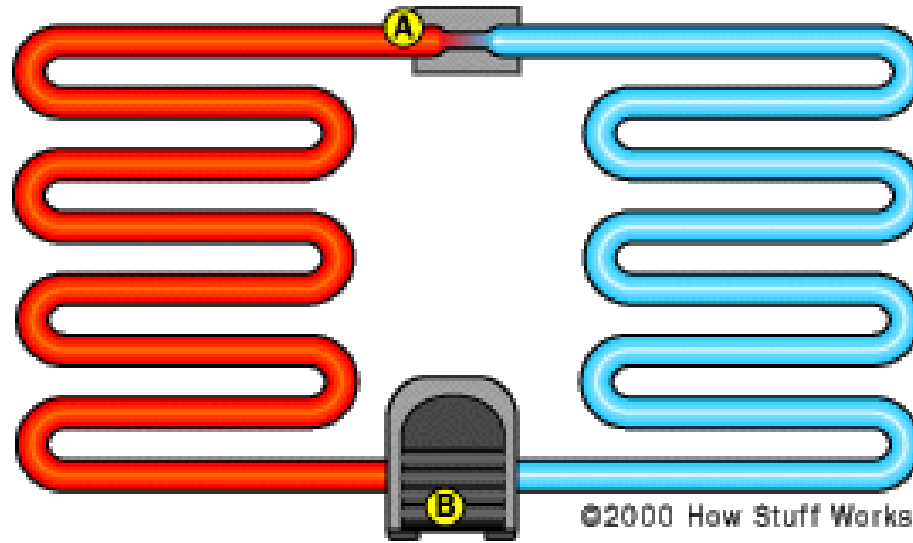

What are the major components?

A typical air conditioner

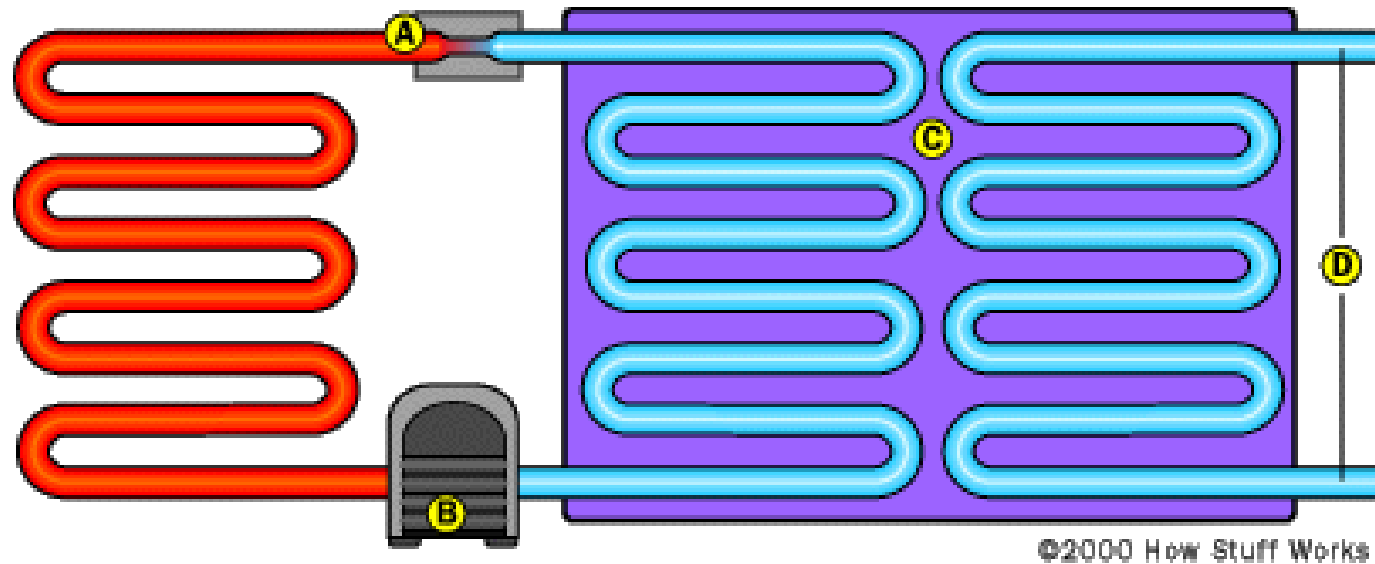

Chilled water system

Air conditioning with a chilled water system

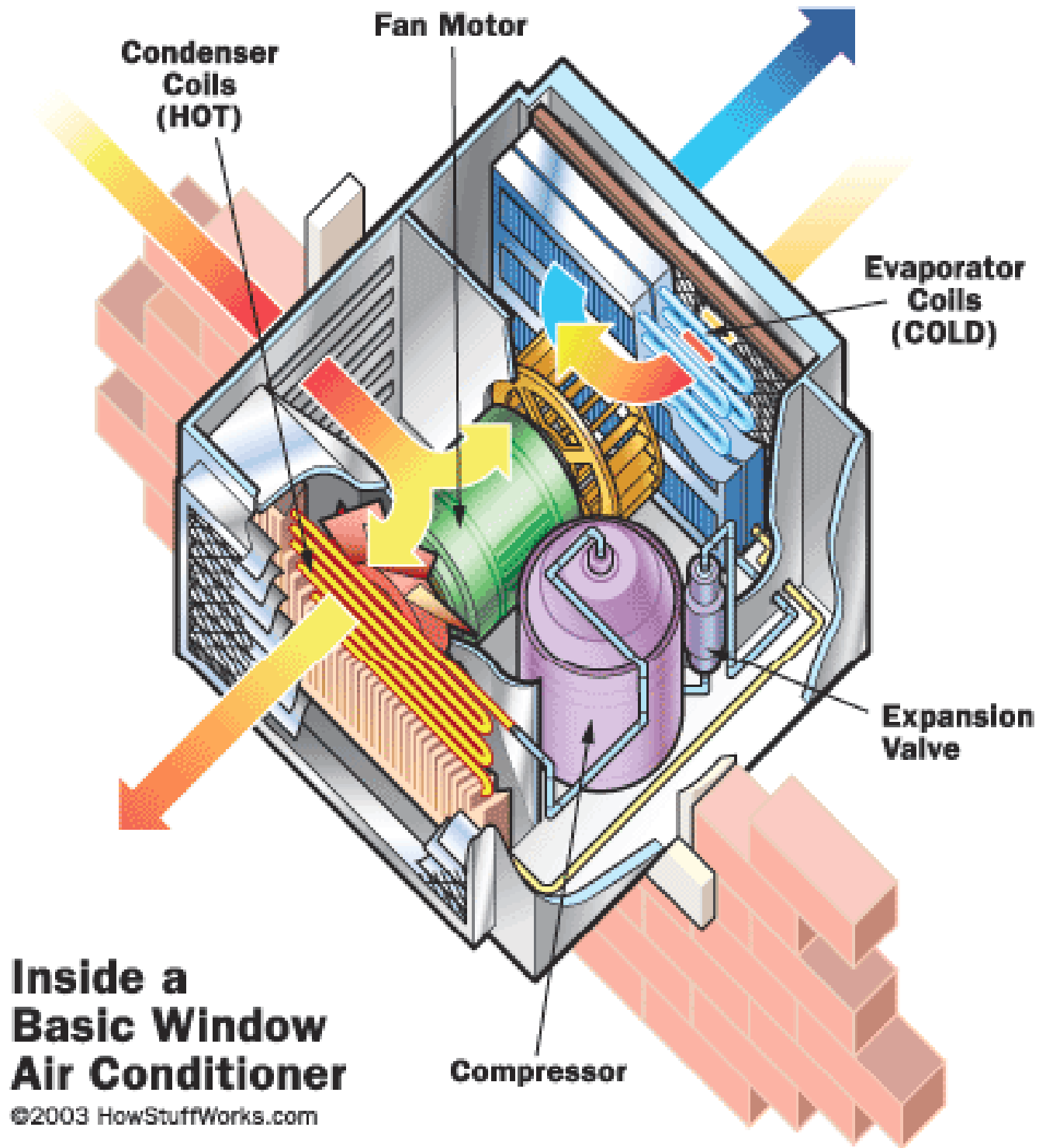

**Inside a
Basic Window
Air Conditioner**

©2003 HowStuffWorks.com

(Source: www.howstuffworks.com/ac.htm)

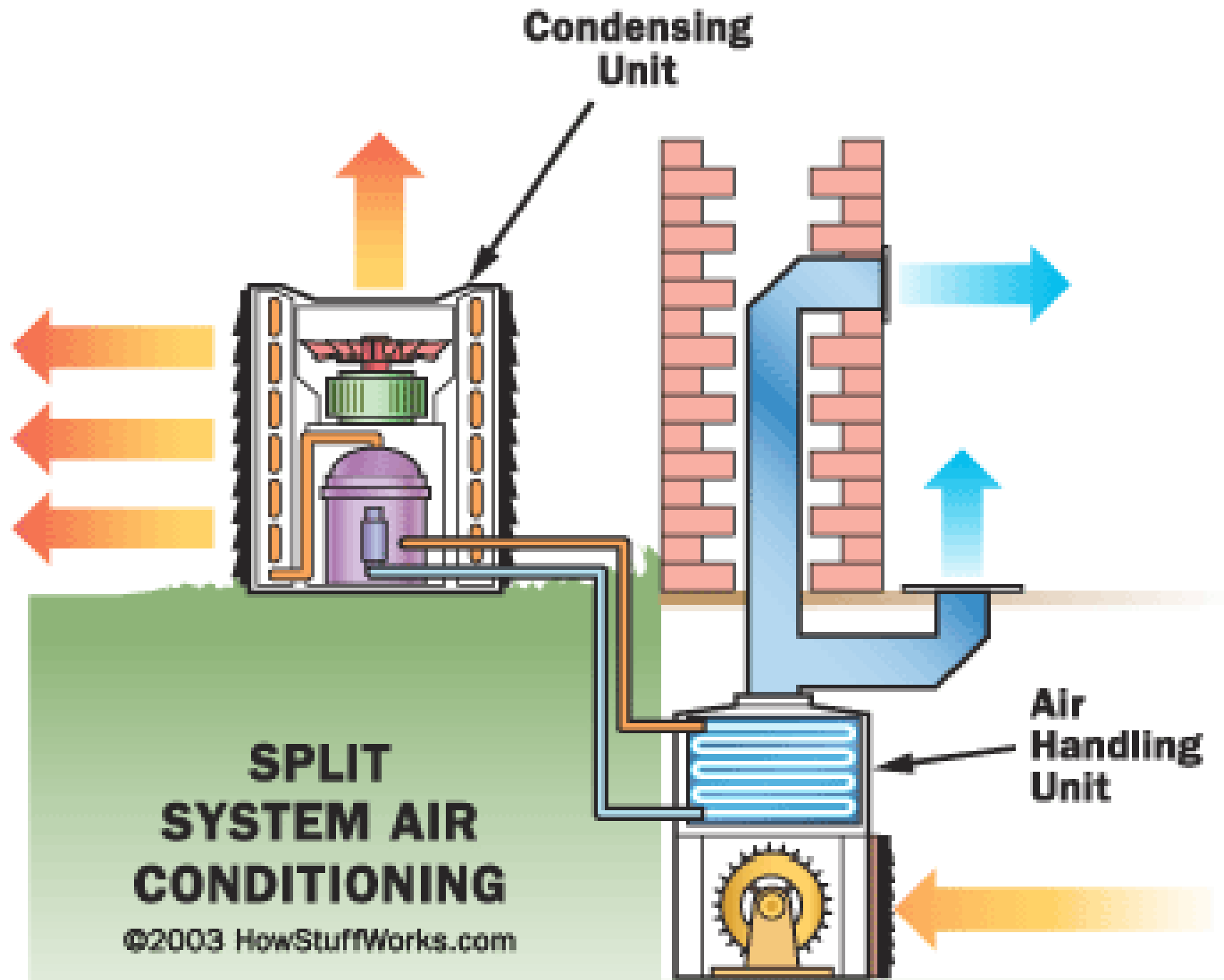

Air Conditioning

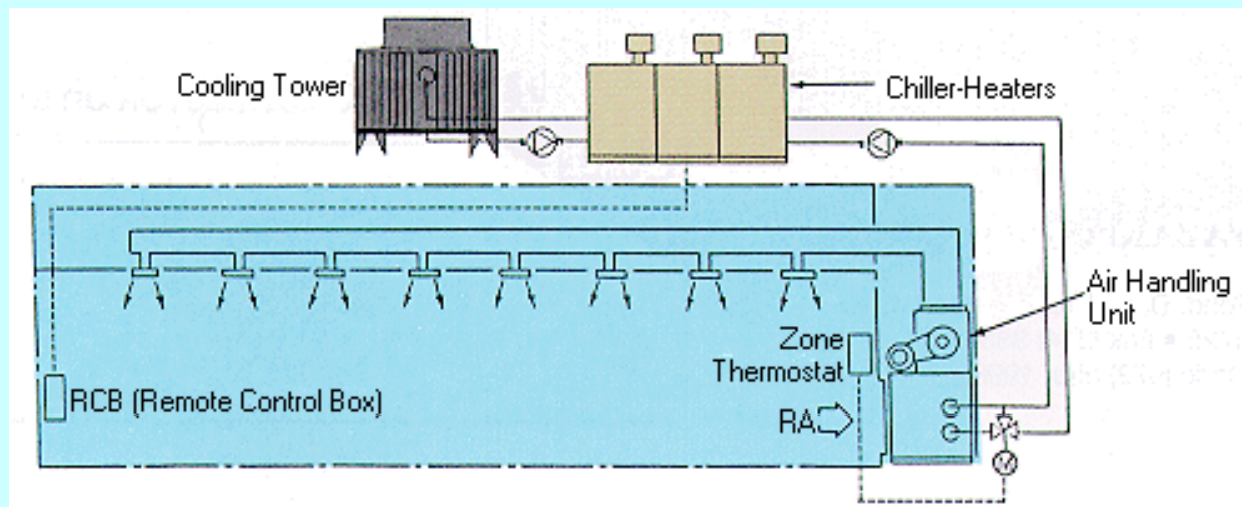
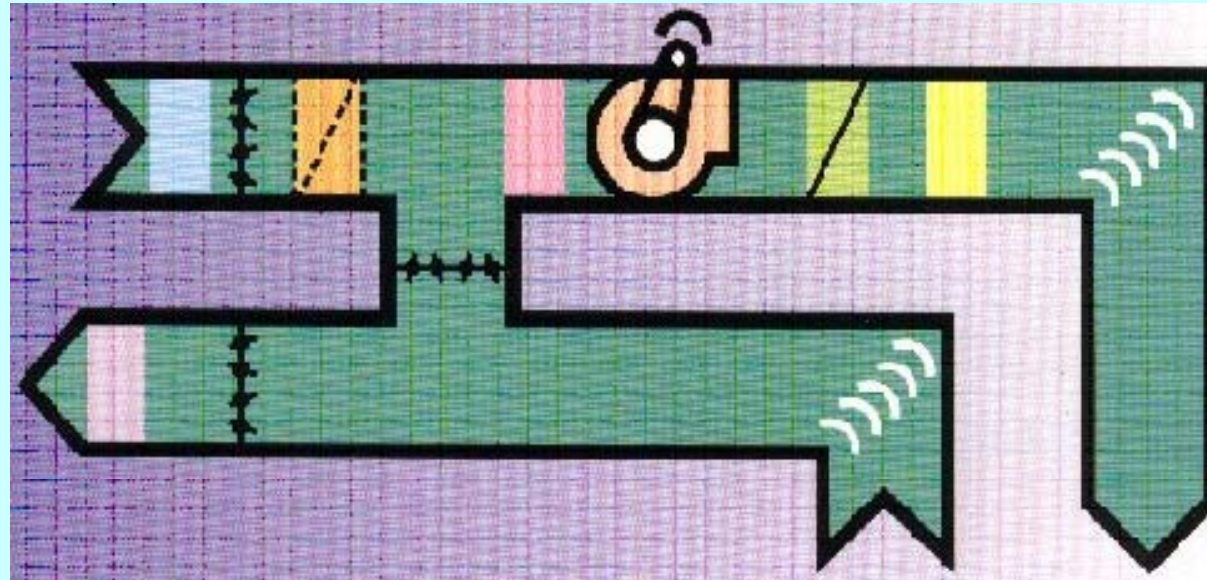



Air Conditioning

- Definition (from ASHRAE*)
 - Air conditioning is the process of treating air so as to control simultaneously its temperature, humidity, cleanliness, and distribution to meet the requirements of the conditioned space.
 - Basic processes: Cooling and Heating
- Comfort air conditioning
 - To meet comfort requirements of occupants

Air Conditioning



- Applications of air conditioning:
 - Industrial air conditioning
 - e.g. textile mills, electronics, pharmaceutical
 - Air conditioning of commercial buildings
 - e.g. offices, hotels, retails
 - Residential air conditioning
 - Air conditioning of vehicles (buses, cars, trains, aircrafts, etc.)

Air Conditioning



- Air Conditioning and Refrigeration
 - No. 10 on the list of the [Greatest Engineering Achievements of the 20th Century]
 - <http://www.greatachievements.org>
 - These cooling technologies have altered some of our most fundamental patterns of living
 - Buildings are climate-controlled & comfortable
 - Fresh foods & milk are kept in refrigerators/freezers
 - Building designs are changed completely
 - Environment for industrial processes are controlled

Air Conditioning



- The History of Air Conditioning

- www.air-conditioners-and-heaters.com/air_conditioning_history.htm



- 1830: Dr. John Gorrie (ice for cooling hospital rooms)
- 1881: James Garfield (device w/ melted ice water)
- Late 19th century: “manufactured air” (controlling humidity in textile mills)
- Early 1900s’: Willis Carrier (designed modern A/C systems for offices, apartments, hotels, hospitals)
- 1917-1930: movie theatres were kept cool by A/C

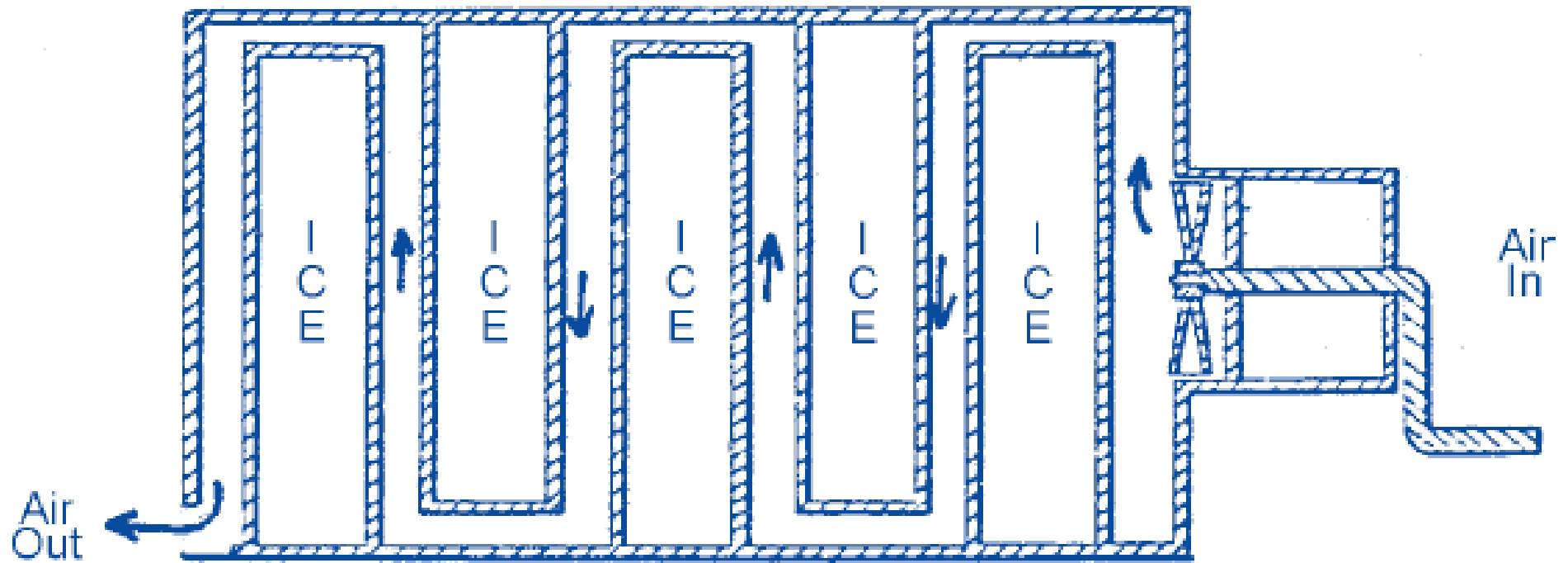

Figure 1: Shaler's patented cooler for ventilating air, 1865.

Air Conditioning



- The Father of Modern Air Conditioning
 - Dr. Willis Haviland Carrier (1875-1950)



- Formed Carrier Air Conditioning Company (1907)
- Published a paper on rational psychrometric formulae in 1911
- Invented and patented many HVAC equipment
- Wrote a well-known air conditioning textbook

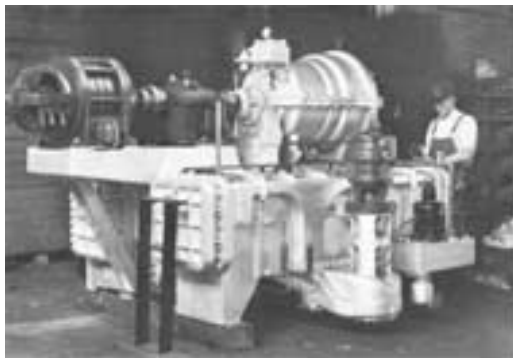

Air Conditioning



- Importance of air conditioning for buildings
 - Change building designs & human adaptation
 - Affect occupant satisfaction, productivity, health and safety
 - Contribute to effective building performance
 - Often form a major part of building construction costs and running costs
 - Affect energy consumption & environmental performance of a building

Air Conditioning



- To understand better, air conditioning system can be divided into five subsystems or loops:
 - Air-side
 - Chilled water
 - Refrigeration equipment
 - Heat rejection
 - Controls



33 °C, 28 °C

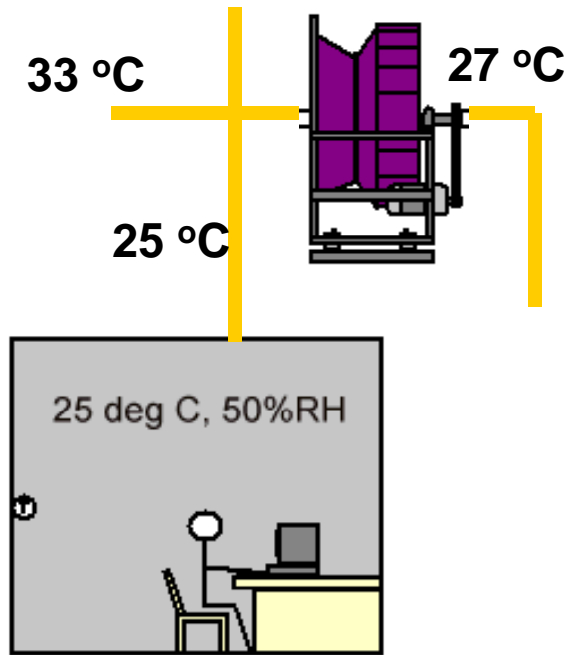

Conditioned space



33 °C, 28 °C

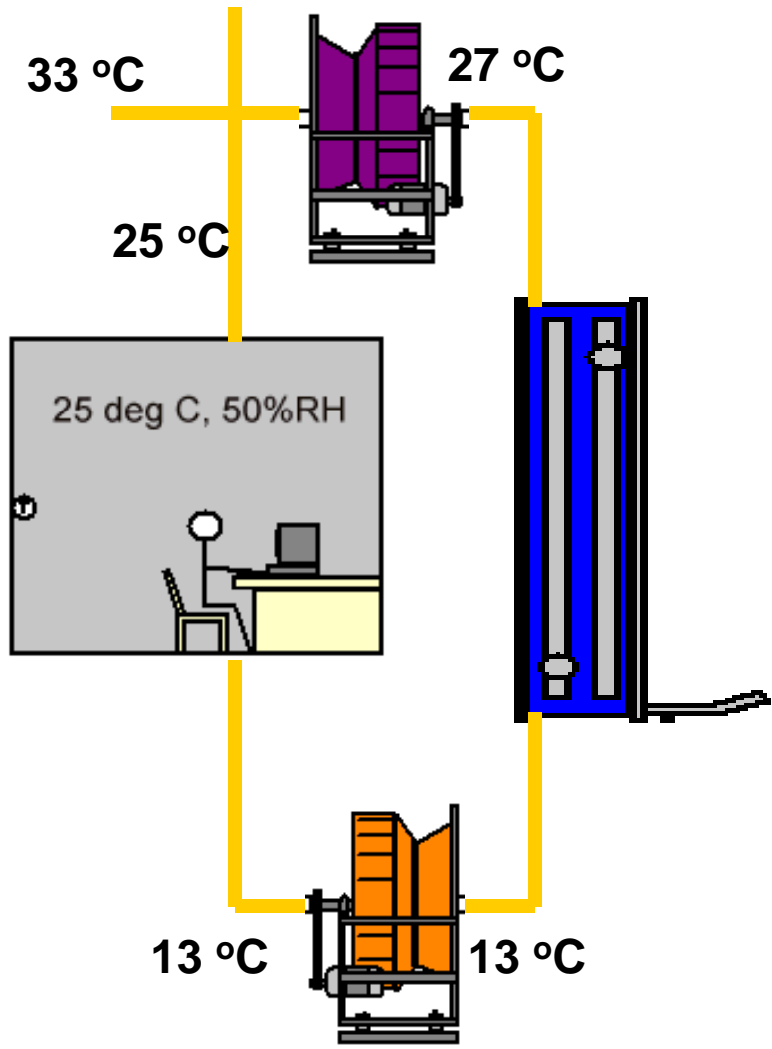

Air side system



33 °C, 28 °C

Chilled water system

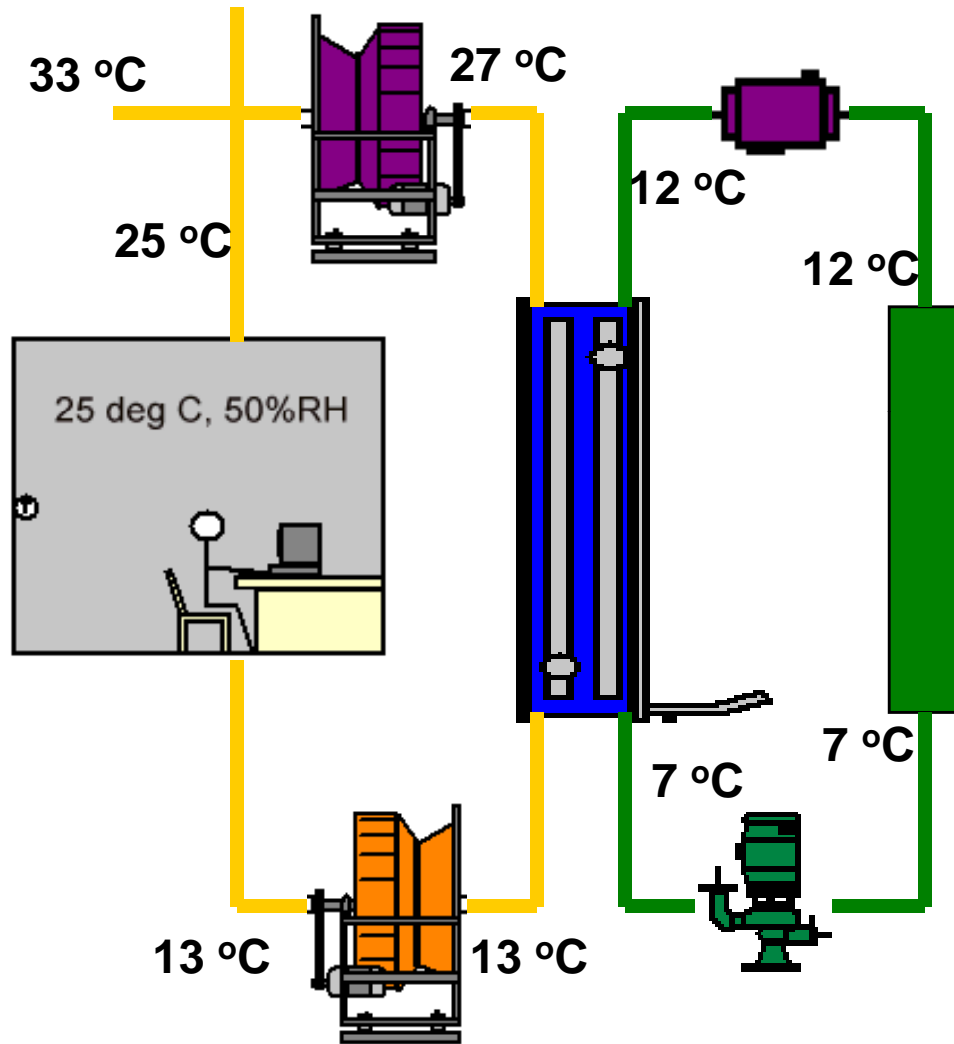



33 °C, 28 °C

Refrigeration equipment

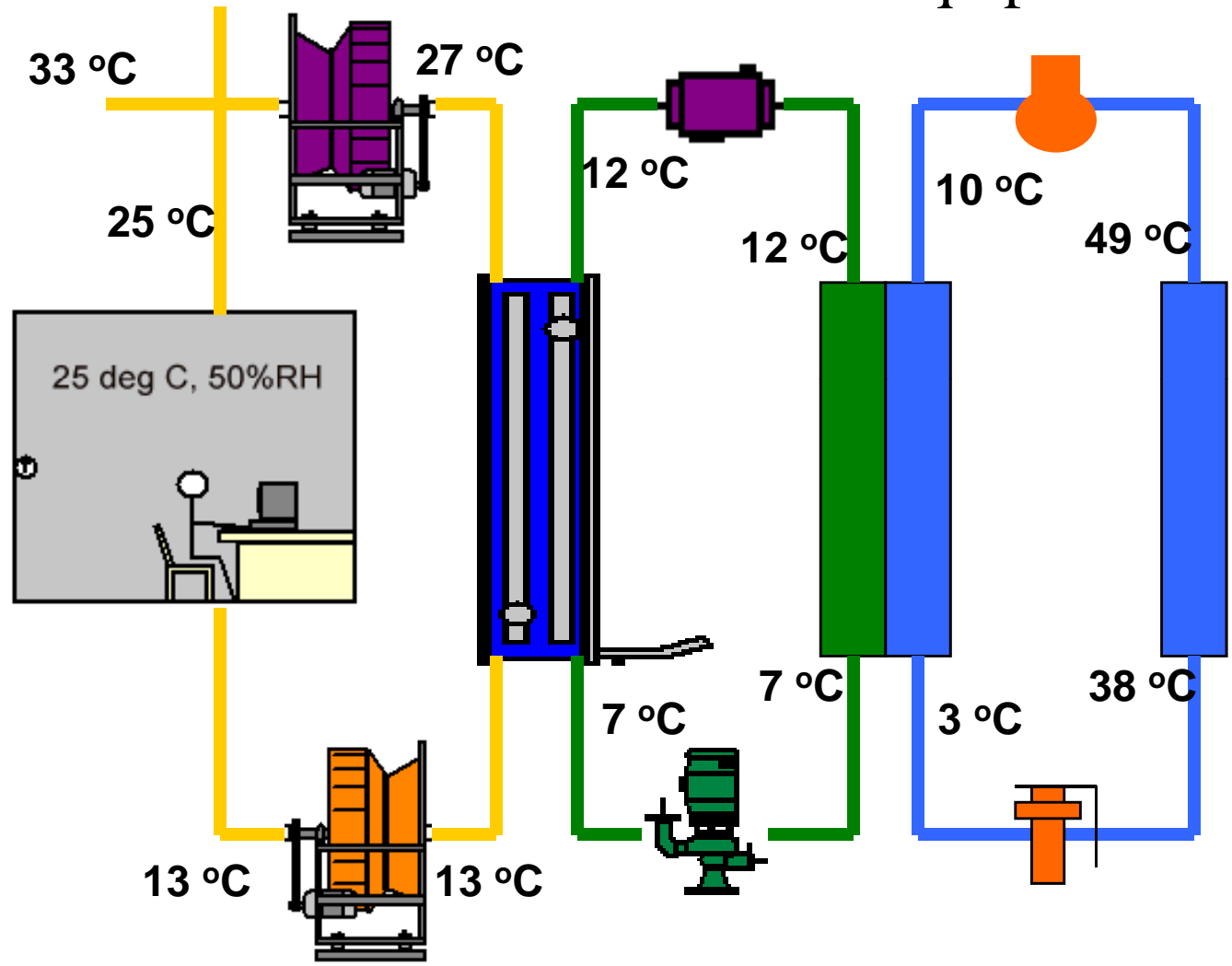



33 °C, 28 °C

Heat rejection

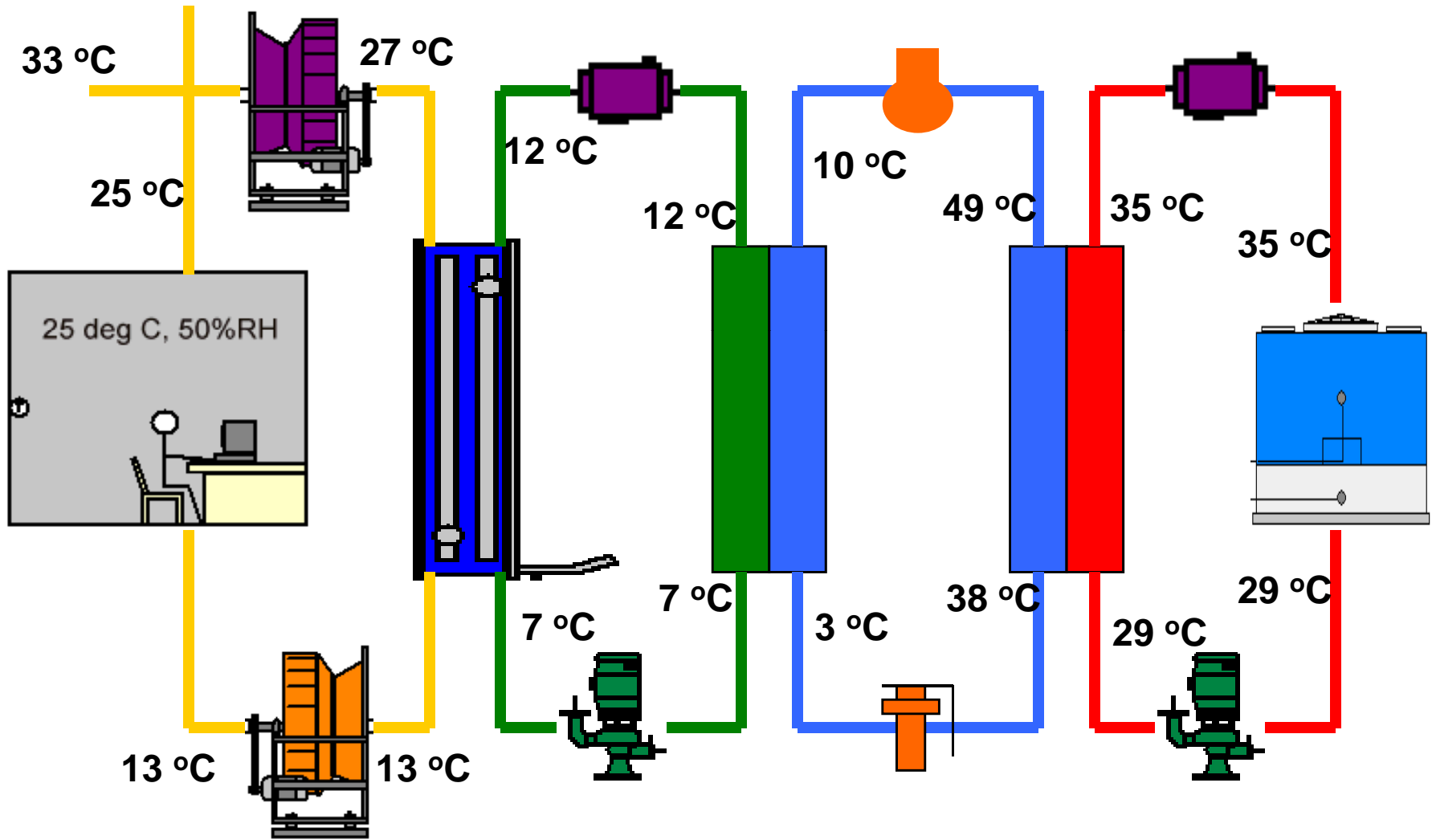



33 °C, 28 °C

Control Loop

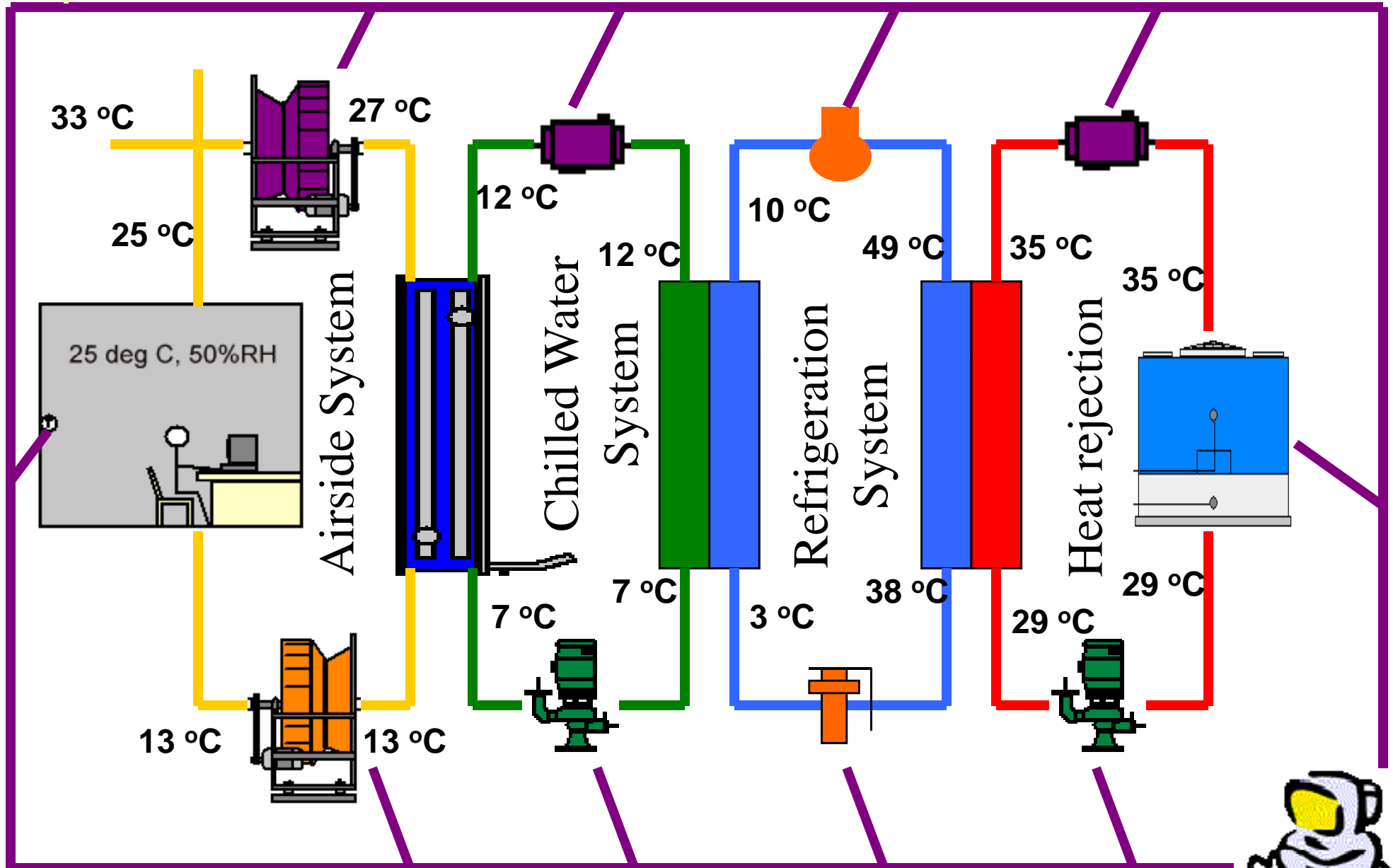

Air Conditioning



- Three generic types of systems:
 - Centralised all air systems
 - Such as CAV, VAV, dual duct
 - Partially centralised air/water systems
 - Such as FCU, induction units, chilled beams/ceilings
 - Local systems
 - Such as window-type units, split-type packages, VRV/VRF (?)

Centralised air system (VAV example)

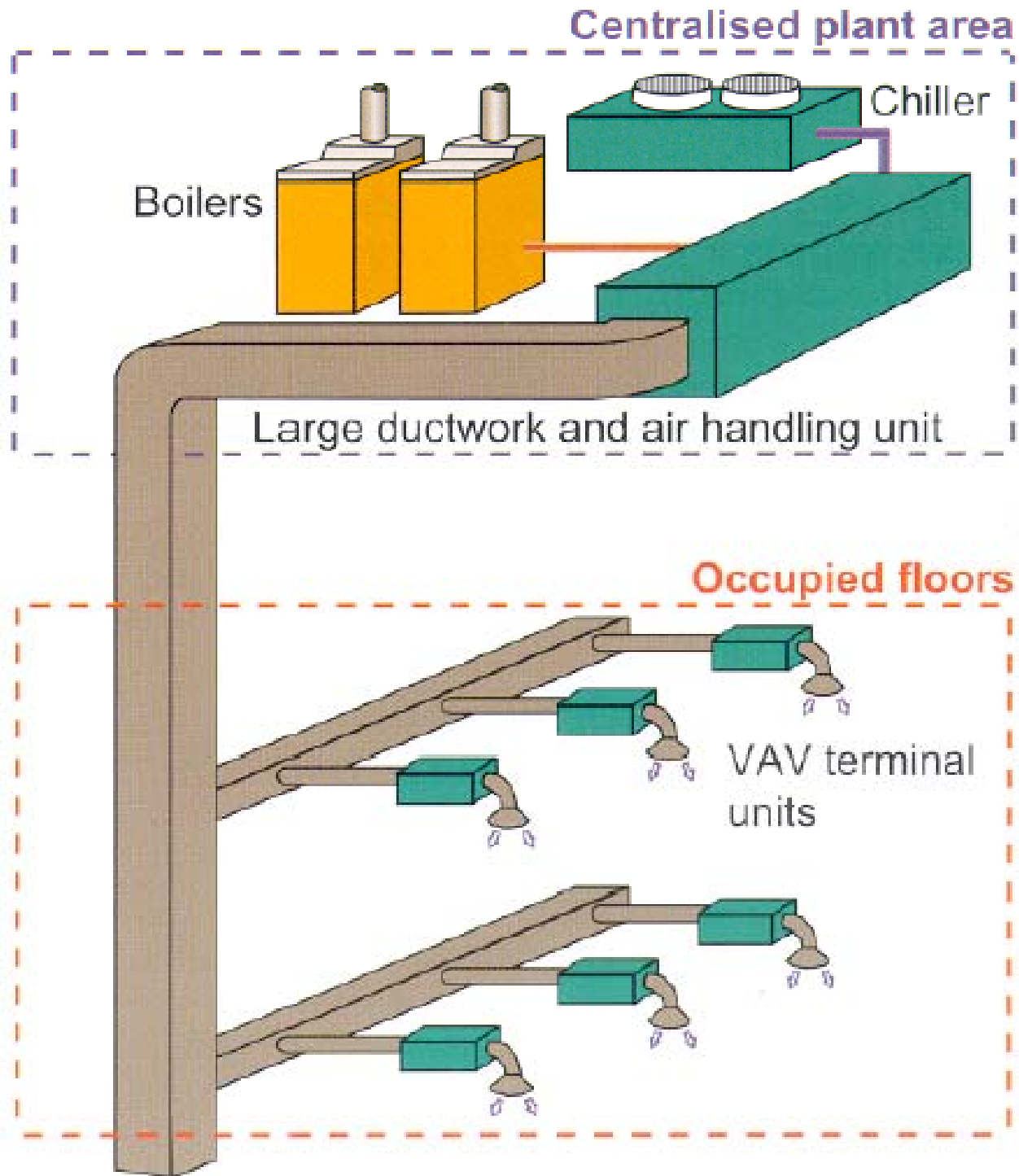

Partially centralised air/water system (Fan coil example)

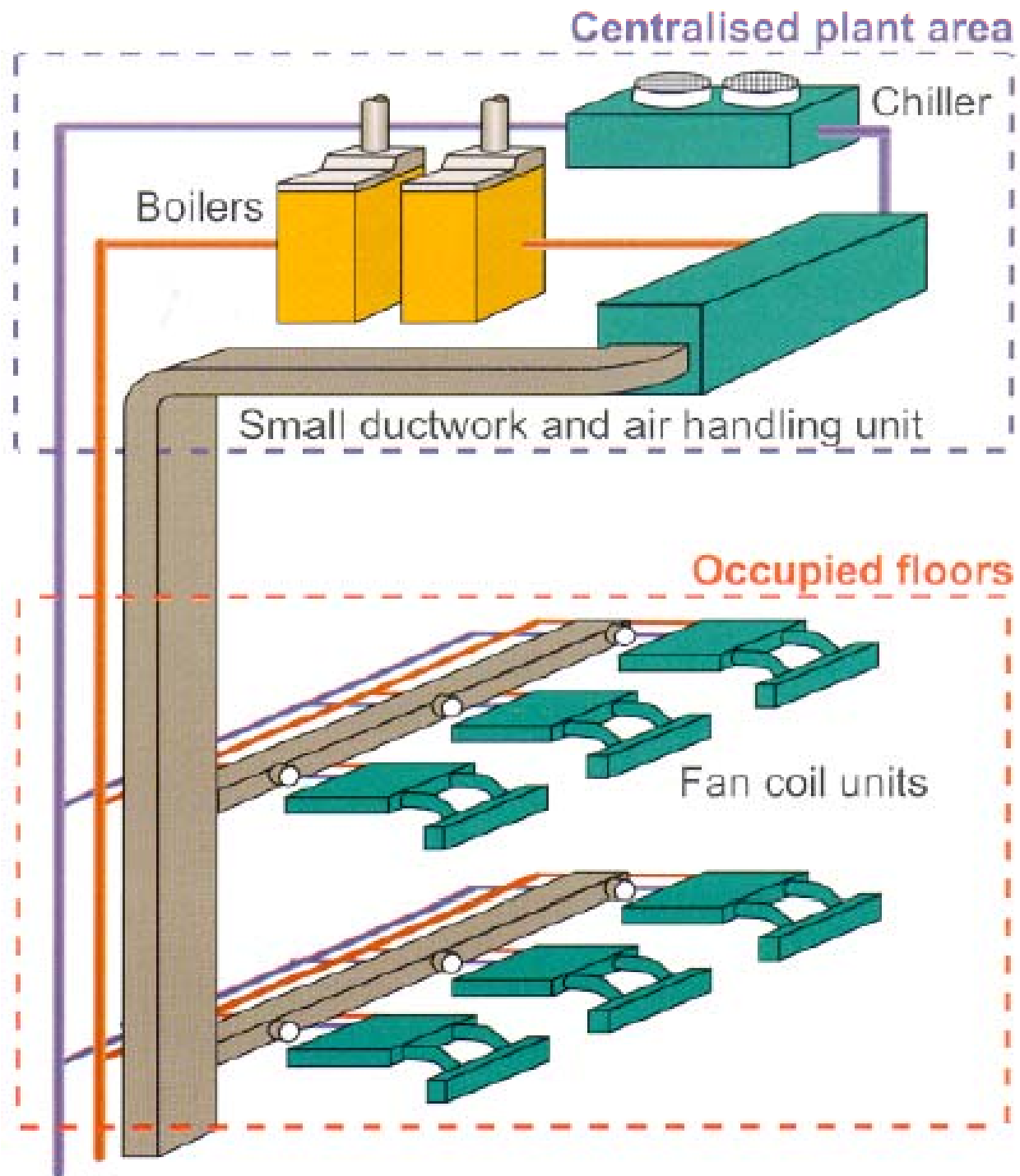

Room
air-conditioner

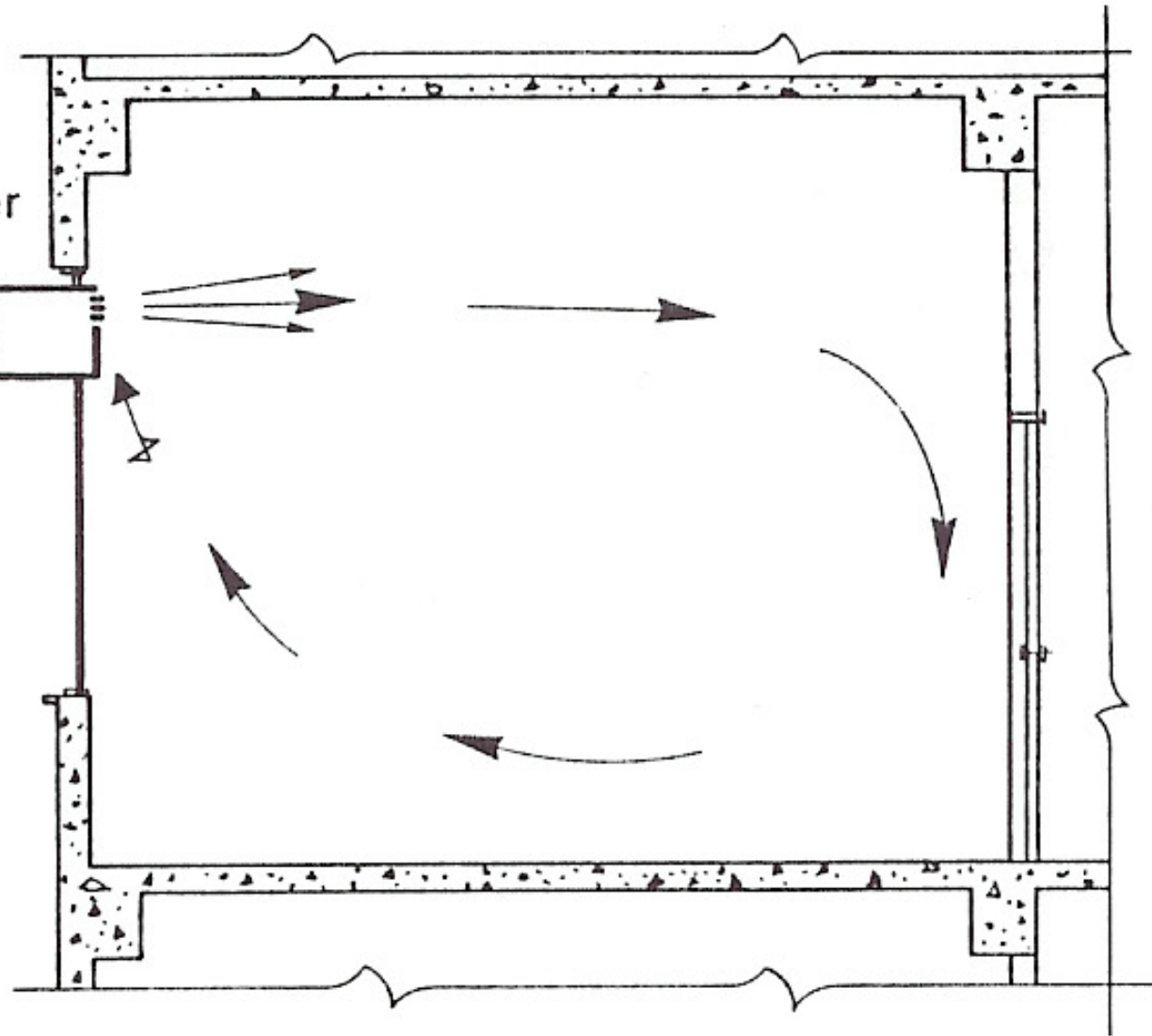

Individual room air-conditioning system

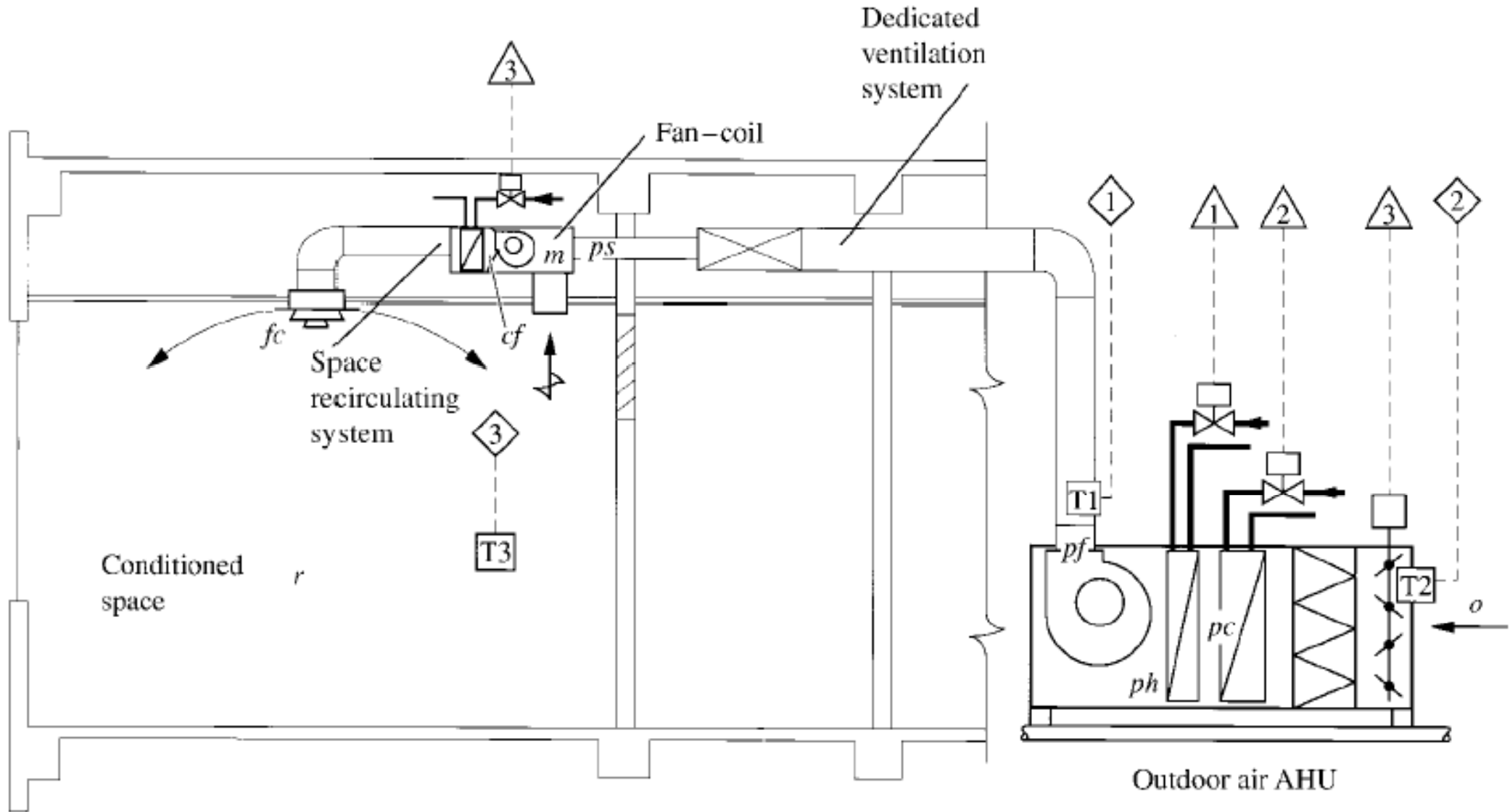

Primary air fan coil unit (PA-FCU) system

Variable-air volume (VAV) package system

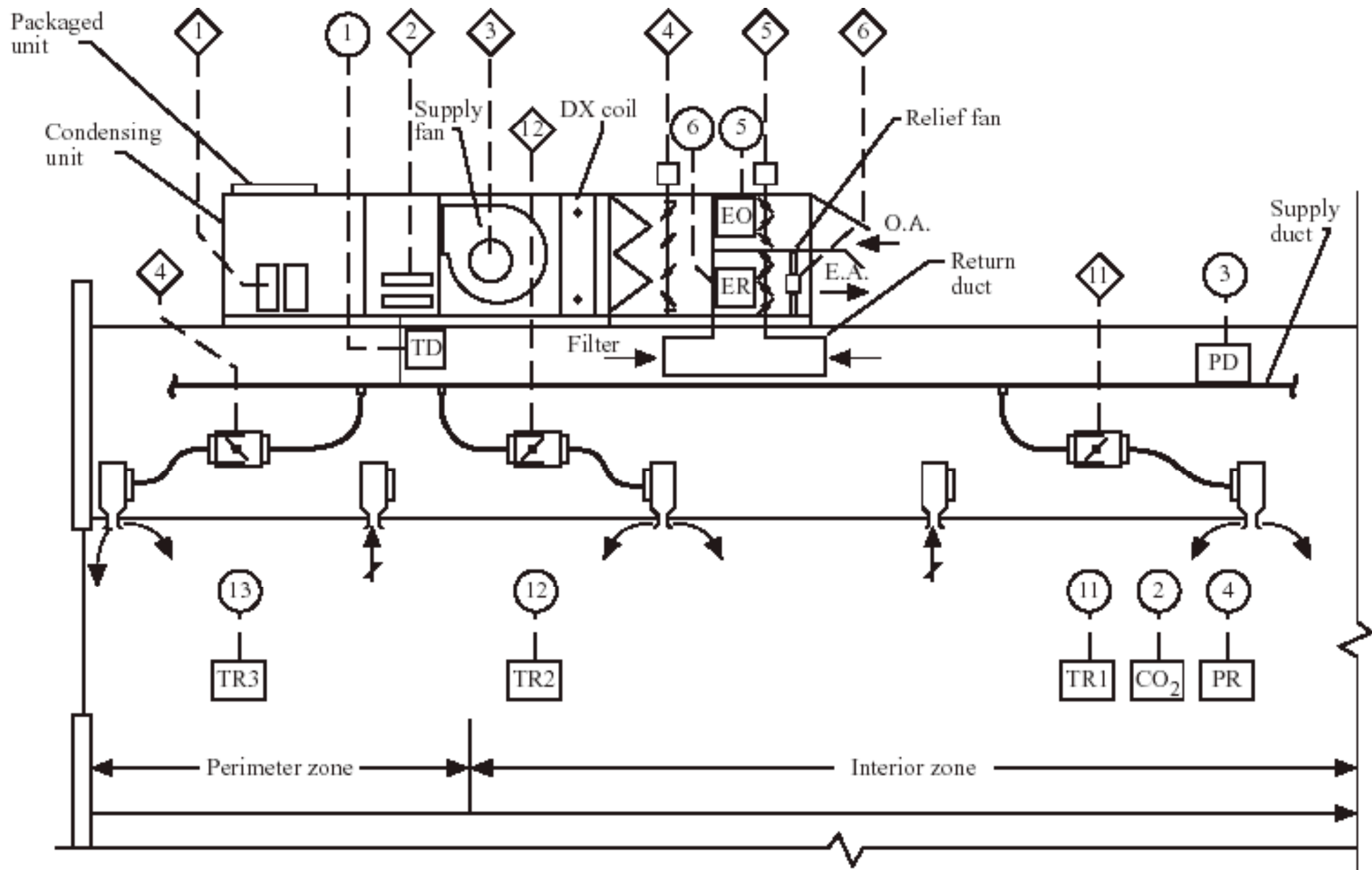

(a)

A dual-duct VAV central system

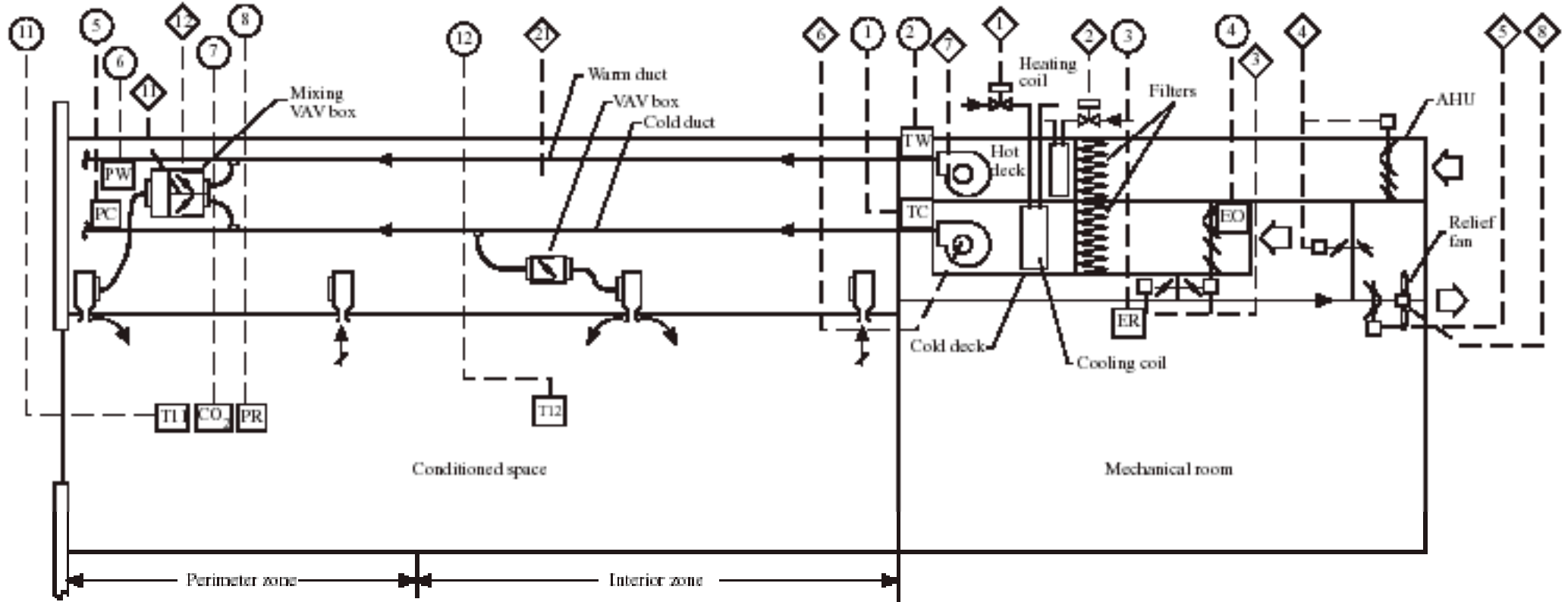

Air Conditioning



- Video presentation: Fundamentals of Air Conditioning [video, 24 min.]
 - HVAC systems at Heathrow Airport, Terminal 4, London
 - Basic psychrometric principles
 - HVAC equipment and components
 - Design factors: building, system, climate, economic



Copyright©1999 Jack Sidener

Hong Kong International Airport



Stansted Airport, UK



KL International Airport, Malaysia



®



ASHRAE

*American
Society of
Heating
Refrigerating &
Air-conditioning
Engineers*

ASHRAE Publications

- Handbooks
 - Fundamentals
 - Systems & Equipment
 - Applications
 - Refrigeration
- Journal
- E-newsletters
- Books

Handbook



Journal

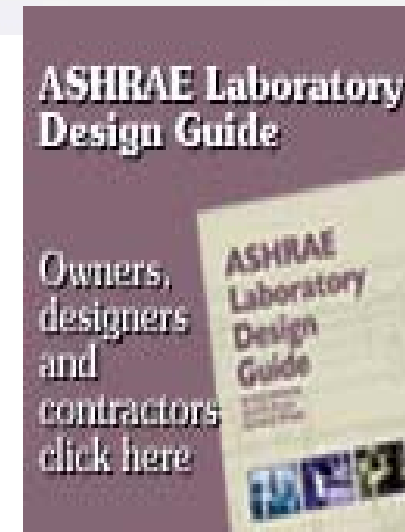

Guidelines

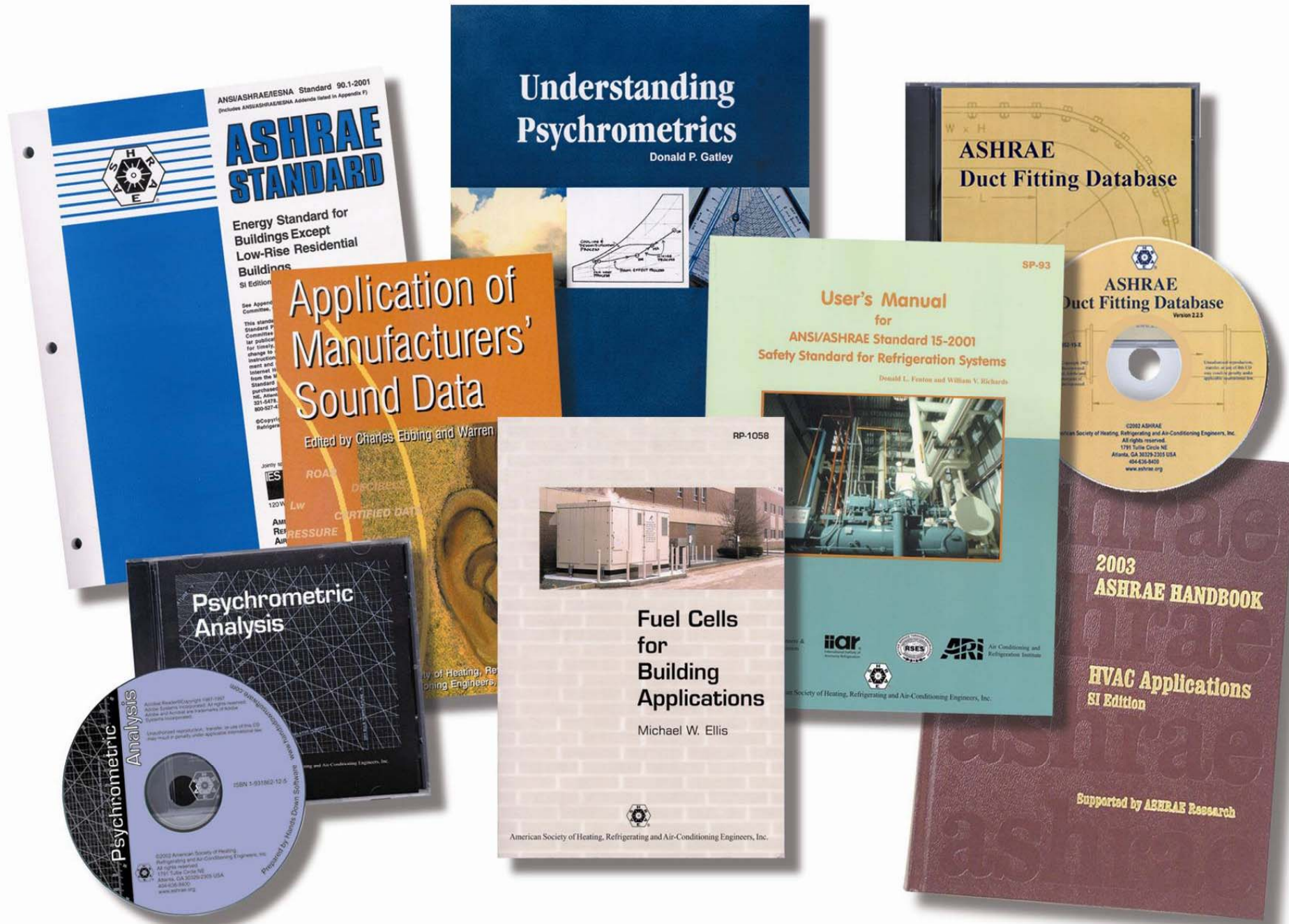

(Source: www.ashrae.org)