

MEBS6006 Environmental Services I

<http://www.hku.hk/bse/MEBS6006/>

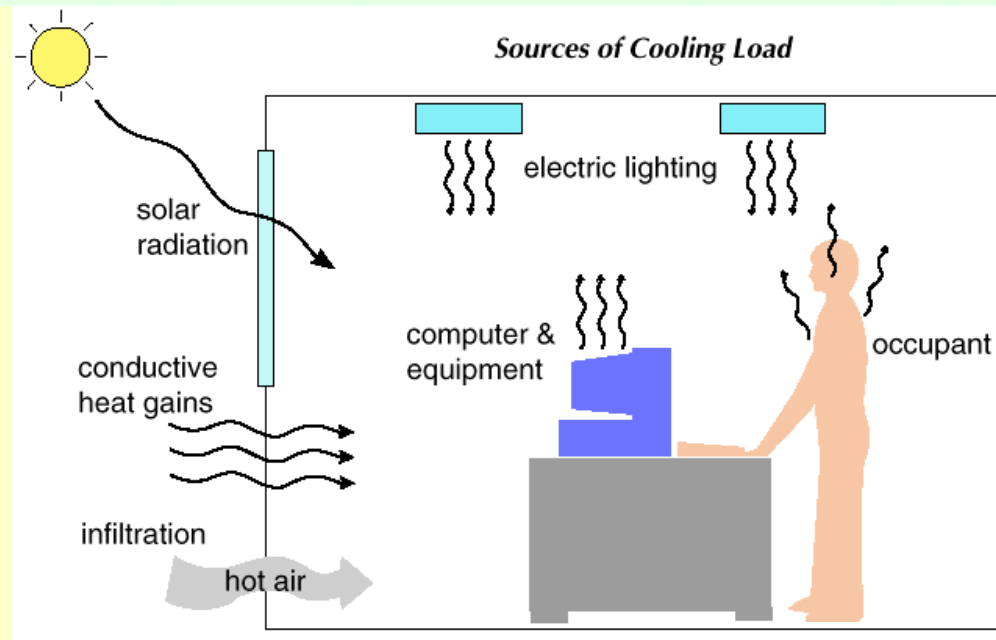

Load Estimation



Dr. Sam C M Hui

Department of Mechanical Engineering

The University of Hong Kong

E-mail: cmhui@hku.hk

Sep 2009

Contents

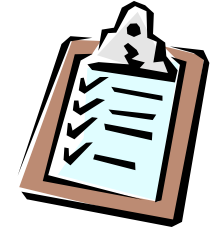

- Basic Concepts
- Outdoor Design Conditions
- Indoor Design Conditions
- Cooling Load Components
- Cooling Load Principles
- Cooling Coil Load
- Heating Load
- Software Applications

Basic Concepts

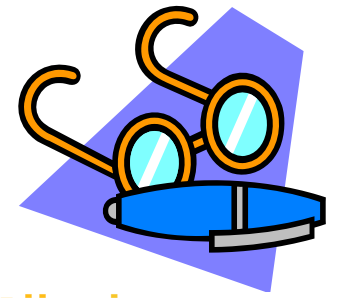

- Heat transfer mechanism

- Conduction
- Convection
- Radiation

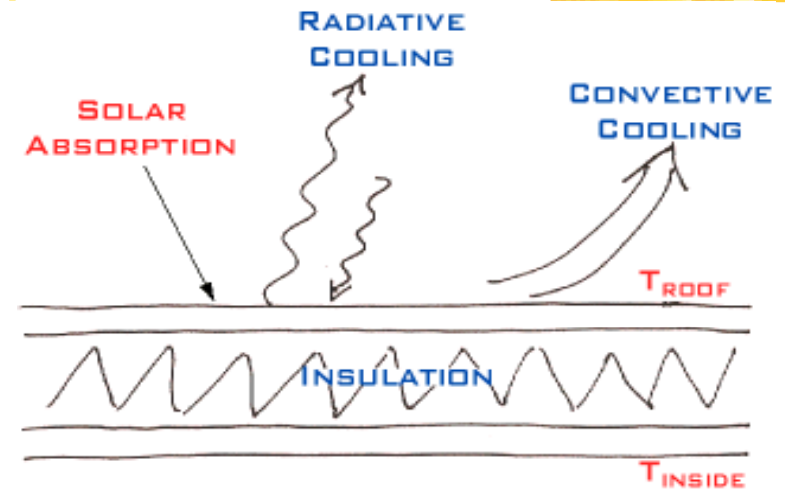

$$Q_{IN} = U \cdot (T_{ROOF} - T_{INSIDE})$$

- Thermal properties of building materials

- Overall thermal transmittance (U-value)
- Thermal conductivity
- Thermal capacity (specific heat)

$$Q = U A (\Delta t)$$

Four forms of heat transfer

CONDUCTION

From molecule to molecule

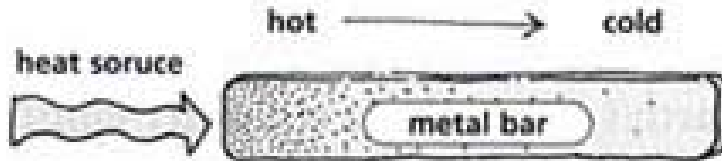

SENSIBLE HEAT

Fluid movement of heated air

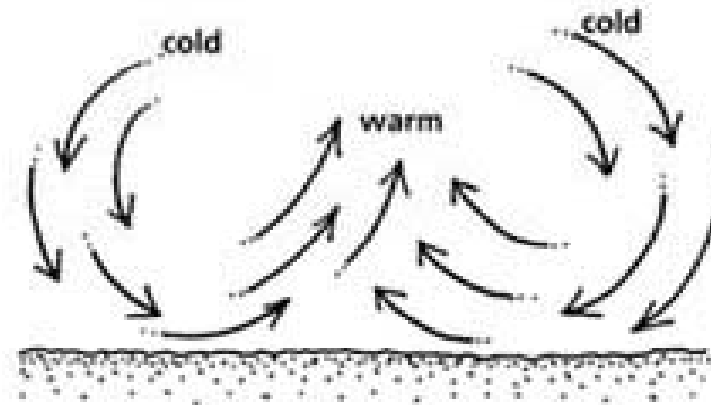

CONVECTION

RADIATION

Energy passing from one object to another without a connecting medium

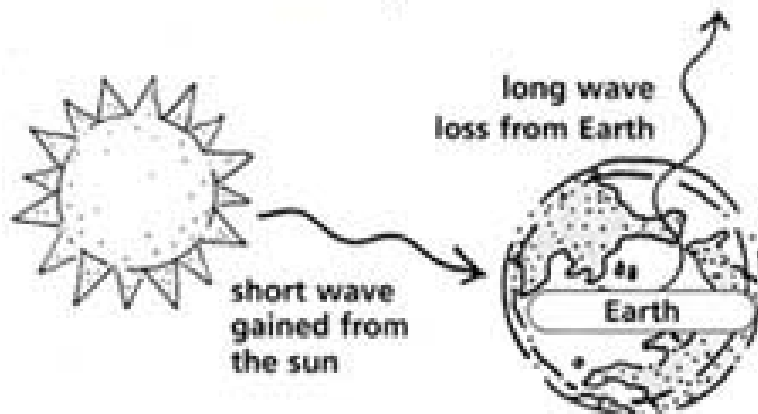

LATENT HEAT

Chemical energy due to water phase changes (evaporation, condensation, etc.) and water vapour transfer

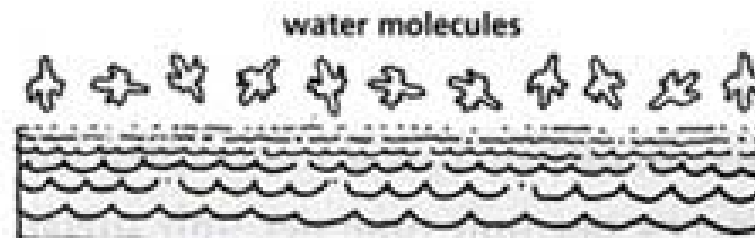

Basic Concepts

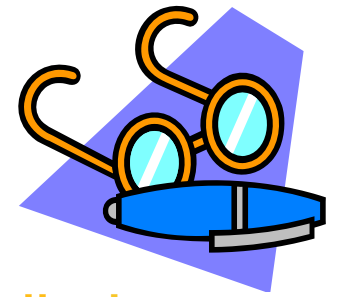

- Heat transfer basic relationships (for air at sea level)
 - Sensible heat transfer rate:
 - $q_{\text{sensible}} = 1.23 \text{ (Flow rate, L/s)} (\Delta t)$
 - Latent heat transfer rate:
 - $q_{\text{latent}} = 3010 \text{ (Flow rate, L/s)} (\Delta w)$
 - Total heat transfer rate:
 - $q_{\text{total}} = 1.2 \text{ (Flow rate, L/s)} (\Delta h)$
 - $q_{\text{total}} = q_{\text{sensible}} + q_{\text{latent}}$

Basic Concepts

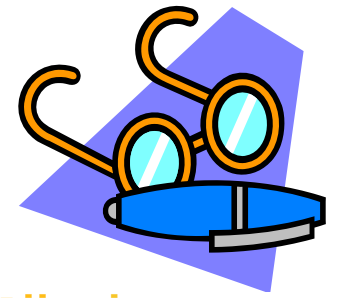

- Thermal load
 - The amount of heat that must be added or removed from the space to maintain the proper temperature in the space
- When thermal loads push conditions outside of the comfort range, HVAC systems are used to bring the thermal conditions back to comfort conditions

Basic Concepts

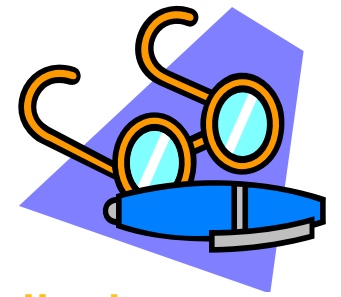

- Purpose of HVAC load estimation
 - Calculate peak design loads (cooling/heating)
 - Estimate likely plant/equipment capacity or size
 - Provide info for HVAC design e.g. load profiles
 - Form the basis for building energy analysis
- Cooling load is our main target
 - Important for warm climates & summer design
 - Affect building performance & its first cost

Basic Concepts

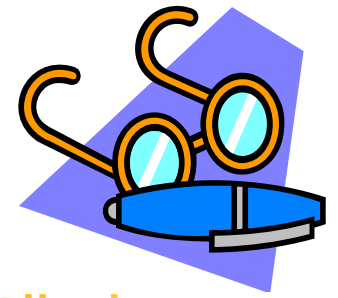

- General procedure for cooling load calculations
 - Obtain the characteristics of the building, building materials, components, etc. from building plans and specifications
 - Determine the building location, orientation, external shading (like adjacent buildings)
 - Obtain appropriate weather data and select outdoor design conditions
 - Select indoor design conditions (include permissible variations and control limits)

Basic Concepts

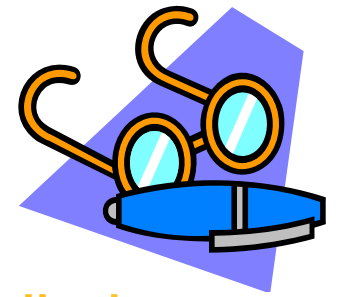

- General procedure for cooling load calculations (cont'd)
 - Obtain a proposed schedule of lighting, occupants, internal equipment appliances and processes that would contribute to internal thermal load
 - Select the time of day and month for the cooling load calculation
 - Calculate the space cooling load at design conditions
 - Assess the cooling loads at several different time or a design day to find out the peak design load

Total Cooling Load - Tons

January Through June

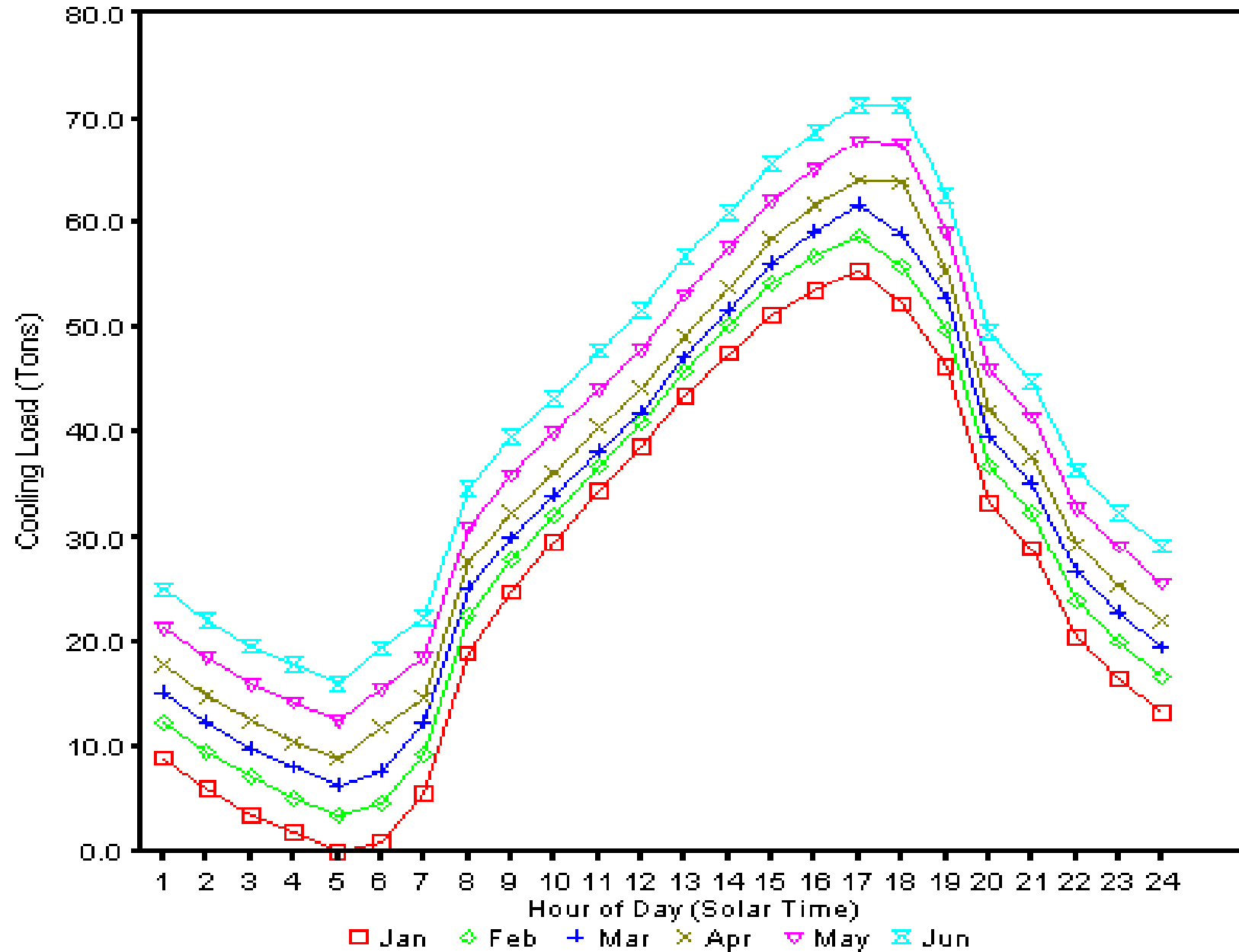

Cooling load profiles

Basic Concepts

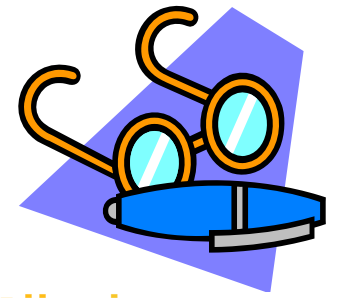

- A building survey will help us achieve a realistic estimate of thermal loads
 - Orientation of the building
 - Use of spaces
 - Physical dimensions of spaces
 - Ceiling height
 - Columns and beams
 - Construction materials
 - Surrounding conditions
 - Windows, doors, stairways

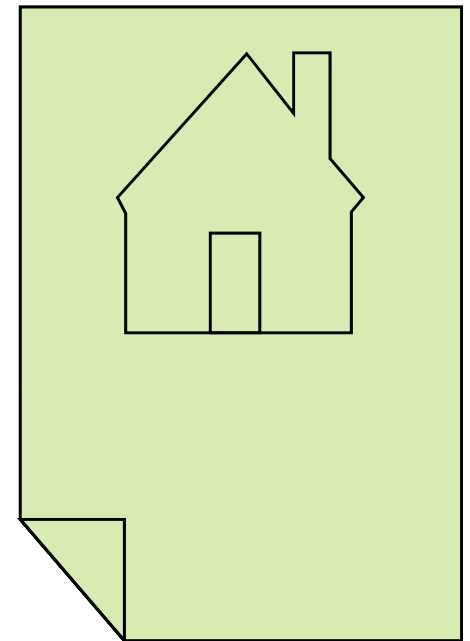

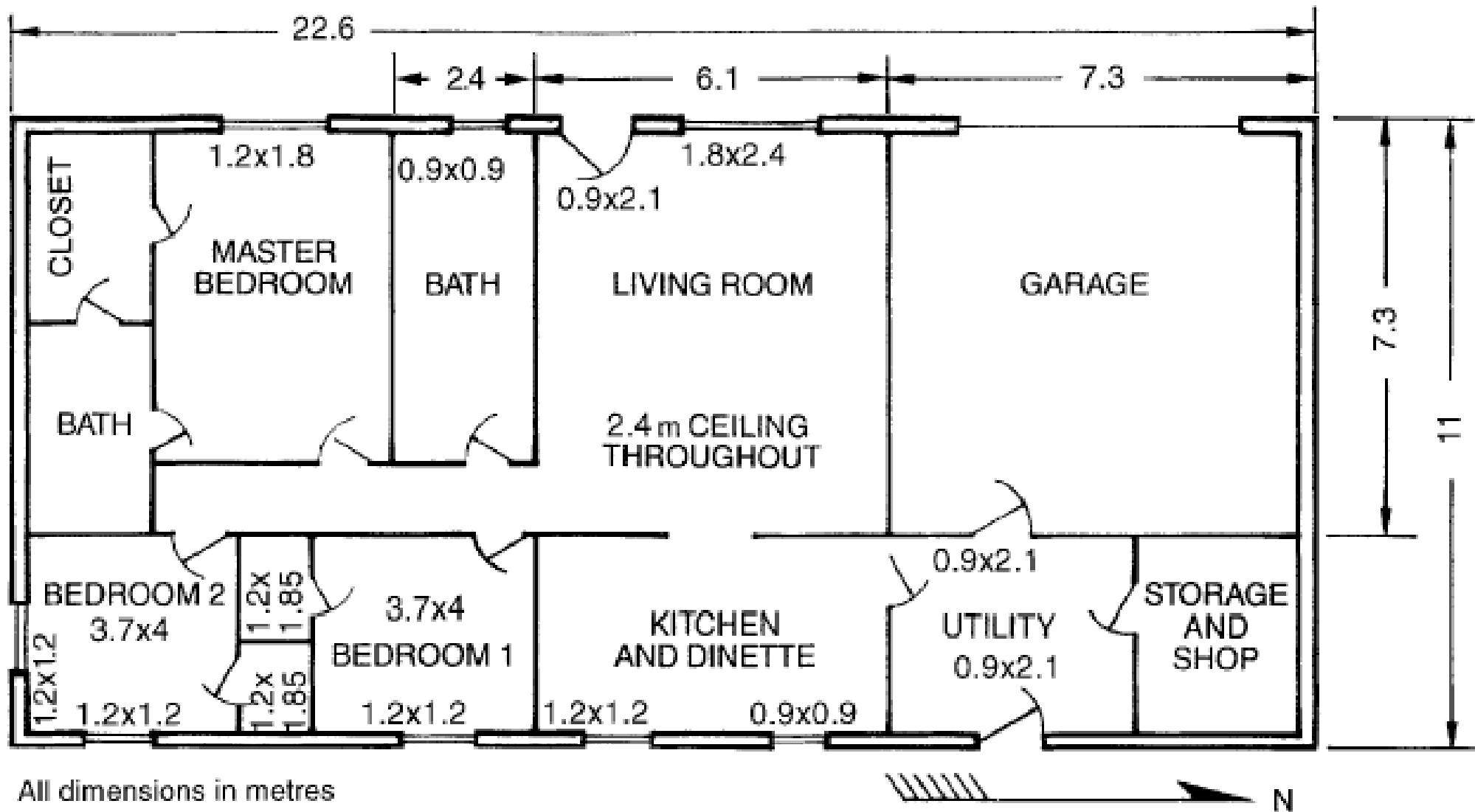

Basic Concepts

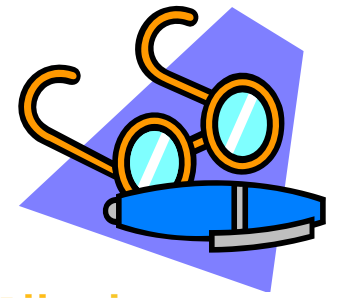

- Key info for load estimation
 - People (number or density, duration of occupancy, nature of activity)
 - Lighting (W/m^2 , type)
 - Appliances (wattage, location, usage)
 - Ventilation (criteria, requirements)
 - Thermal storage (if any)
 - Continuous or intermittent operation

Basic Concepts

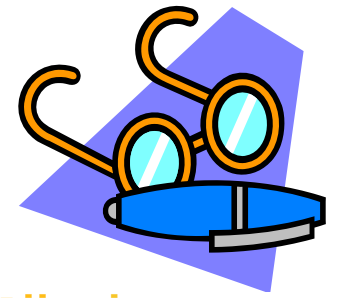

- Typical HVAC load design process
 - 1. Rough estimates of design loads & energy use
 - Such as by rules of thumb & floor areas
 - See “Cooling Load Check Figures”
 - See references for some examples of databooks
 - 2. Develop & assess more info (design criteria, building info, system info)
 - Building layouts & plans are developed
 - 3. Perform detailed load & energy calculations

Outdoor Design Conditions

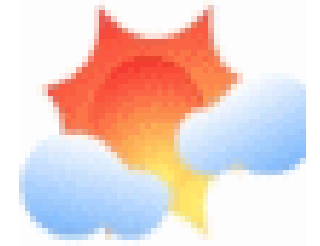

- They are used to calculate design space loads
- Climatic design information
 - General info: e.g. latitude, longitude, altitude, atmospheric pressure
 - Outdoor design conditions include
 - Derived from statistical analysis of weather data
 - Typical data can be found in handbooks/databooks, such as ASHRAE Fundamentals Handbook

Outdoor Design Conditions

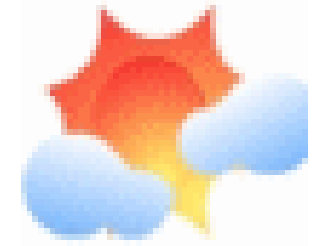

- Climatic design info from ASHRAE
 - Previous data & method (before 1997)
 - For Summer (Jun to Sep) & Winter (Dec, Jan, Feb)
 - Based on 1%, 2.5% & 5% nos. hours of occurrence
 - New method (ASHRAE Fundamentals 2001+):
 - Based on annual percentiles and cumulative frequency of occurrence, e.g. 0.4%, 1%, 2% (of whole year)
 - More info on coincident conditions
 - Findings obtained from ASHRAE research projects
 - Data can be found on a relevant CD-ROM

Outdoor Design Conditions

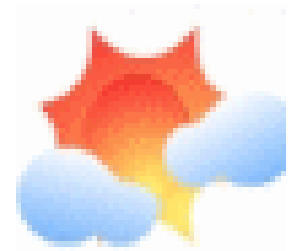

- Climatic design conditions (ASHRAE, 2009):
 - Annual heating & humidif. design conditions
 - Coldest month
 - Heating dry-bulb (DB) temp.
 - Humidification dew point (DP)/ mean coincident dry-bulb temp. (MCDB) and humidity ratio (HR)
 - Coldest month wind speed (WS)/mean coincident dry-bulb temp. (MCDB)
 - Mean coincident wind speed (MCWS) & prevailing coincident wind direction (PCWD) to 99.6% DB

Outdoor Design Conditions

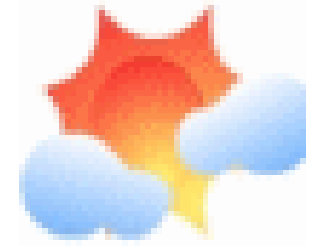

- Climatic design conditions (ASHRAE, 2009):
 - Cooling and dehumidification design conditions
 - Hottest month and DB range
 - Cooling DB/MCWB: Dry-bulb temp. (DB) + Mean coincident wet-bulb temp. (MCWB)
 - Evaporation WB/MCDB: Web-bulb temp. (WB) + Mean coincident dry-bulb temp. (MCDB)
 - MCWS/PCWD to 0.4% DB
 - Dehumidification DP/MCDB and HR: Dew-point temp. (DP) + MDB + Humidity ratio (HR)
 - Enthalpy/MCDB

Outdoor Design Conditions

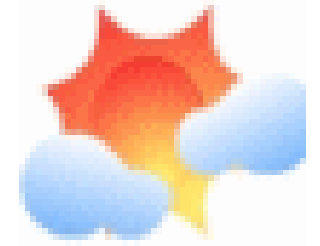

- Climatic design conditions (ASHRAE, 2009):
 - Extreme annual design conditions
 - Monthly climatic design conditions
 - Temperature, degree-days and degree-hours
 - Monthly design DB and mean coincident WB
 - Monthly design WB and mean coincident DB
 - Mean daily temperature range
 - Clear sky solar irradiance

Outdoor Design Conditions

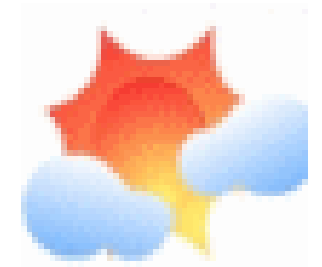

- Other sources of climatic info:
 - Joint frequency tables of psychrometric conditions
 - Annual, monthly and hourly data
 - Degree-days (cooling/heating) & climatic normals
 - To classify climate characteristics
 - Typical year data sets (1 year: 8,760 hours)
 - For energy calculations & analysis

Recommended Outdoor Design Conditions for Hong Kong

Location	Hong Kong (latitude 22° 18' N, longitude 114° 10' E, elevation 33 m)				
Weather station	Royal Observatory Hong Kong				
Summer months	June to September (four hottest months), total 2928 hours				
Winter months	December, January & February (three coldest months), total 2160 hours				
Design temperatures:	For comfort HVAC (based on summer 2.5% or annualised 1% and winter 97.5% or annualised 99.3%)		For critical processes (based on summer 1% or annualised 0.4% and winter 99% or annualised 99.6%)		
	Summer	Winter	Summer	Winter	
	DDB / CWB	32.0 °C / 26.9 °C	9.5 °C / 6.7 °C	32.6 °C / 27.0 °C	8.2 °C / 6.0 °C
	CDB / DWB	31.0 °C / 27.5 °C	10.4 °C / 6.2 °C	31.3 °C / 27.8 °C	9.1 °C / 5.0 °C

- Note:
1. DDB is the design dry-bulb and CWB is the coincident wet-bulb temperature with it; DWB is the design wet-bulb and CDB is the coincident dry-bulb with it.
 2. The design temperatures and daily ranges were determined based on hourly data for the 35-year period from 1960 to 1994; extreme temperatures were determined based on extreme values between 1884-1939 and 1947-1994.

(Source: Research findings from Dr. Sam C M Hui)

Recommended Outdoor Design Conditions for Hong Kong (cont'd)

Extreme temperatures:	Hottest month: July mean DBT = 28.6 °C absolute max. DBT = 36.1 °C mean daily max. DBT = 25.7 °C		Coldest month: January mean DBT = 15.7 °C absolute min. DBT = 0.0 °C mean daily min. DBT = 20.9 °C	
Diurnal range:	Summer	Winter	Whole year	
- Mean DBT	28.2	16.4	22.8	
- Daily range	4.95	5.01	5.0	
Wind data:	Summer	Winter	Whole year	
- Wind direction	090 (East)	070 (N 70° E)	080 (N 80° E)	
- Wind speed	5.7 m/s	6.8 m/s	6.3 m/s	

Note: 3. Wind data are the prevailing wind data based on the weather summary for the 30-year period 1960-1990. Wind direction is the prevailing wind direction in degrees clockwise from north and the wind speed is the mean prevailing wind speed.

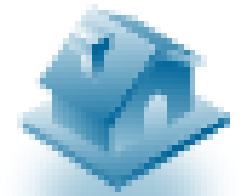

Indoor Design Conditions

- Basic design parameters: (for thermal comfort)
 - Air temp. & air movement
 - Typical: summer 24-26 °C; winter 21-23 °C
 - Air velocity: summer < 0.25 m/s; winter < 0.15 m/s
 - Relative humidity
 - Summer: 40-50% (preferred), 30-65 (tolerable)
 - Winter: 25-30% (with humidifier); not specified (w/o humidifier)
 - See also ASHRAE Standard 55-2004
 - ASHRAE comfort zone

ASHRAE Comfort Zones

(based on 2004 version of ASHRAE Standard 55)

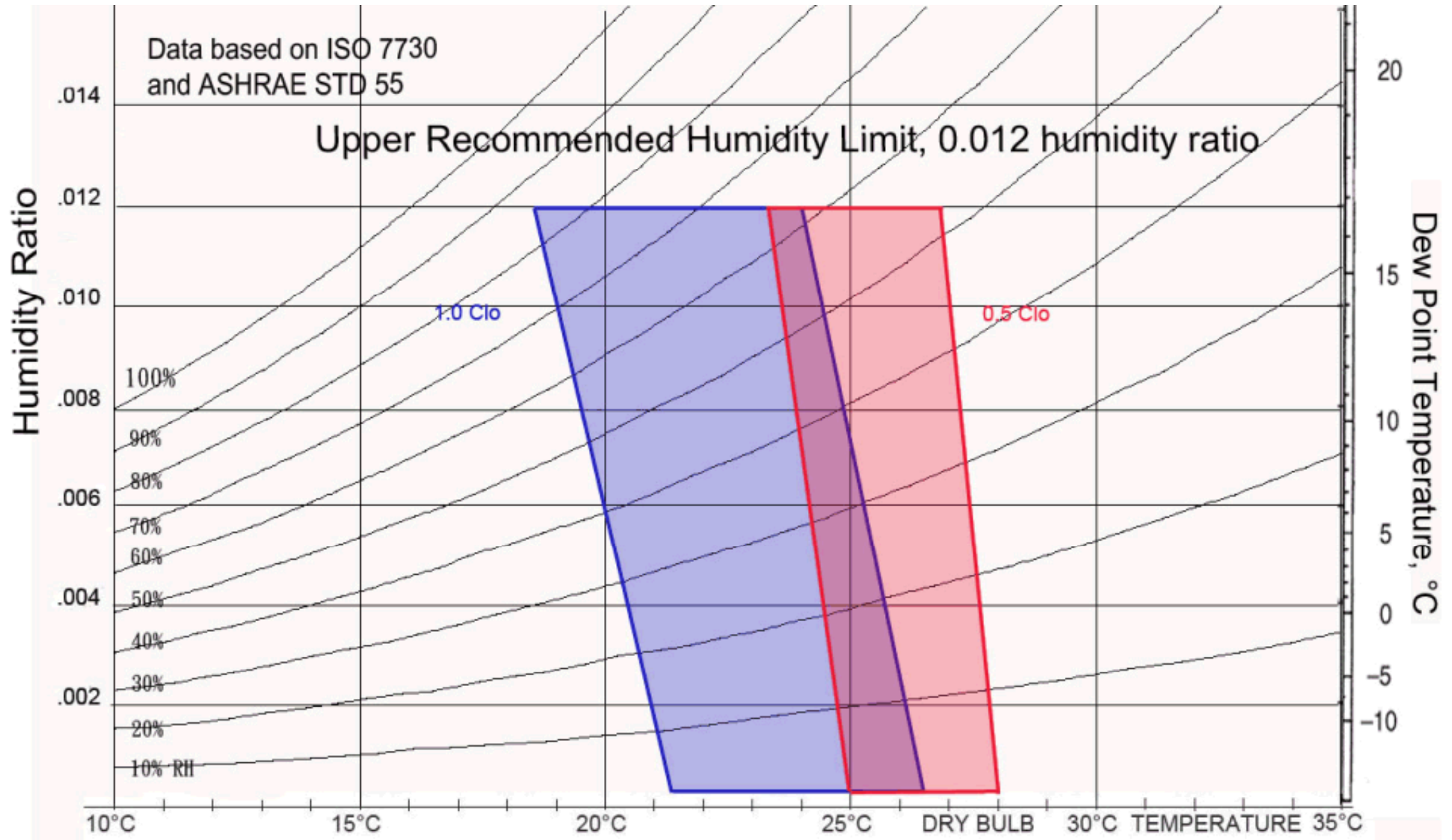

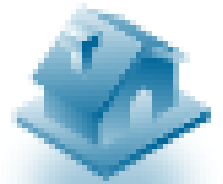

Indoor Design Conditions

- Indoor air quality: (for health & well-being)
 - Air contaminants
 - e.g. particulates, VOC, radon, bioeffluents
 - Outdoor ventilation rate provided
 - ASHRAE Standard 62-2007
 - Air cleanliness (e.g. for processing), air movement
- Other design parameters:
 - Sound level (noise criteria)
 - Pressure differential between the space & surroundings (e.g. +ve to prevent infiltration)

Type of area	Recommended NC or RC range (dB)
Hotel guest rooms	30–35
Office	
Private	30–35
Conference	25–30
Open	30–35
Computer equipment	40–45
Hospital, private	25–30
Churches	25–30
Movie theaters	30–35

(NC = noise criteria; RC = room criteria)

* Remark: buildings in HK often have higher NC, say add 5-10 dB (more noisy).

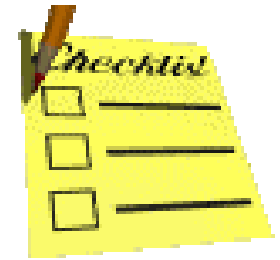

Cooling Load Components

- External
 - 1. Heat gain through exterior walls and roofs
 - 2. Solar heat gain through fenestrations (windows)
 - 3. Conductive heat gain through fenestrations
 - 4. Heat gain through partitions & interior doors
- Internal
 - 1. People
 - 2. Electric lights
 - 3. Equipment and appliances

Cooling Load Components

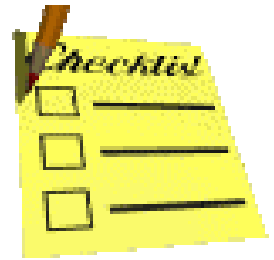

- Infiltration

- Air leakage and moisture migration, e.g. flow of outdoor air into a building through cracks, unintentional openings, normal use of exterior doors for entrance

- System (HVAC)

- Outdoor ventilation air
- System heat gain: duct leakage & heat gain, reheat, fan & pump energy, energy recovery

Sources of Cooling Load

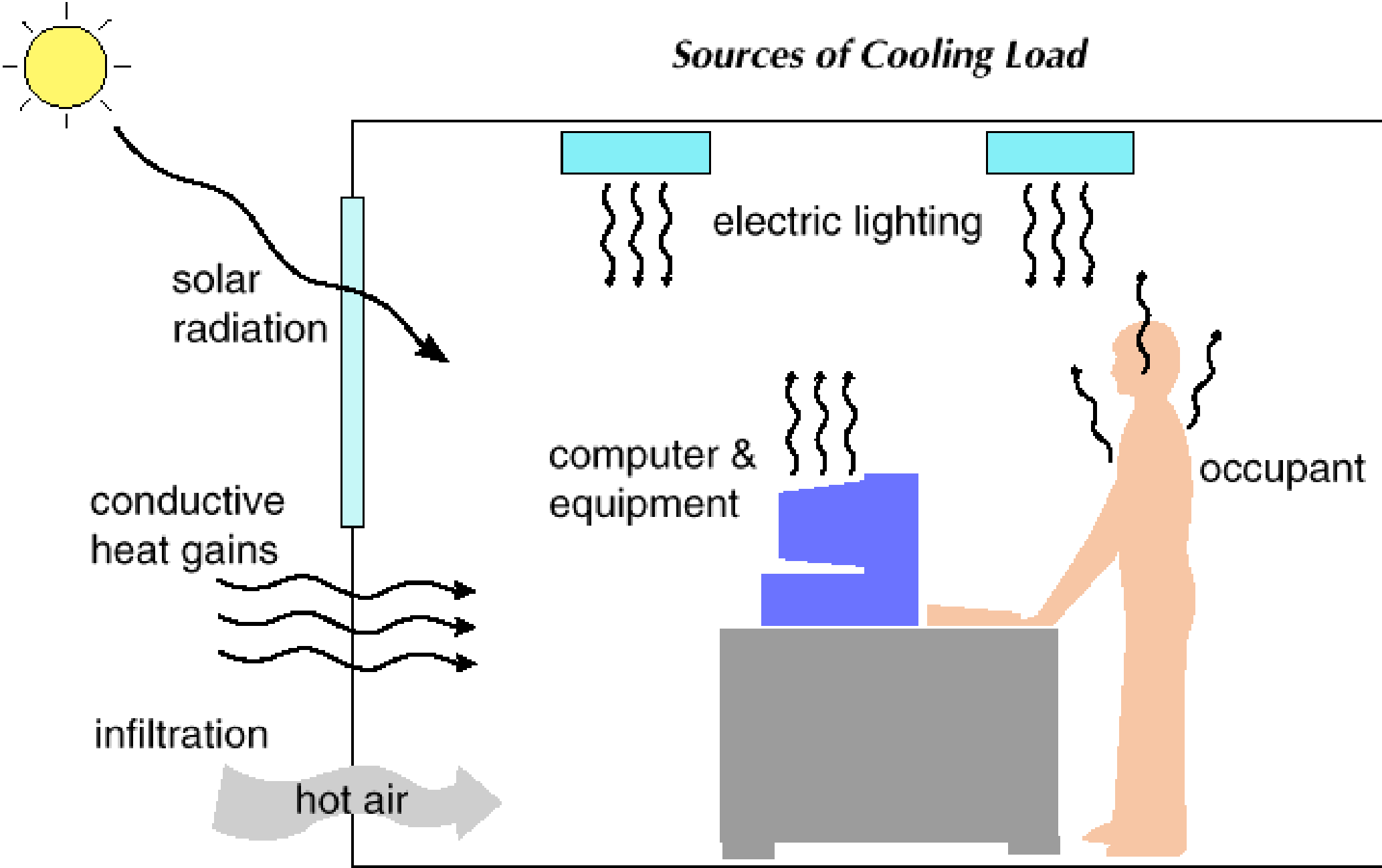

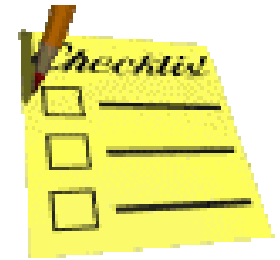

Cooling Load Components

- Total cooling load
 - Sensible cooling load + Latent cooling load
 - = $\Sigma(\text{sensible items}) + \Sigma(\text{latent items})$
- Which components have latent loads? Which only have sensible load? Why?
- Three major parts for load calculation
 - External cooling load
 - Internal cooling load
 - Ventilation and infiltration air

Table 1 Representative Rates at Which Heat and Moisture Are Given Off by Human Beings in Different States of Activity

Degree of Activity		Total Heat, W		Sensible Heat, W	Latent Heat, W	% Sensible Heat that is Radiant ^b	
		Adult Male	Adjusted, M/F ^a			Low V	High V
Seated at theater	Theater, matinee	115	95	65	30		
Seated at theater, night	Theater, night	115	105	70	35	60	27
Seated, very light work	Offices, hotels, apartments	130	115	70	45		
Moderately active office work	Offices, hotels, apartments	140	130	75	55		
Standing, light work; walking	Department store; retail store	160	130	75	55	58	38
Walking, standing	Drug store, bank	160	145	75	70		
Sedentary work	Restaurant ^c	145	160	80	80		
Light bench work	Factory	235	220	80	140		
Moderate dancing	Dance hall	265	250	90	160	49	35
Walking 4.8 km/h; light machine work	Factory	295	295	110	185		
Bowling ^d	Bowling alley	440	425	170	255		
Heavy work	Factory	440	425	170	255	54	19
Heavy machine work; lifting	Factory	470	470	185	285		
Athletics	Gymnasium	585	525	210	315		

Notes:

1. Tabulated values are based on 24°C room dry-bulb temperature. For 27°C room dry bulb, the total heat remains the same, but the sensible heat values should be decreased by approximately 20%, and the latent heat values increased accordingly.
 2. Also refer to [Table 4](#), Chapter 8, for additional rates of metabolic heat generation.
 3. All values are rounded to nearest 5 W.
- ^aAdjusted heat gain is based on normal percentage of men, women, and children for the application listed, with the postulate that the gain from an adult female is

85% of that for an adult male, and that the gain from a child is 75% of that for an adult male.

^bValues approximated from data in [Table 6](#), Chapter 8, where v is air velocity with limits shown in that table.

^cAdjusted heat gain includes 18 W for food per individual (9 W sensible and 9 W latent).

^dFigure one person per alley actually bowling, and all others as sitting (117 W) or standing or walking slowly (231 W).

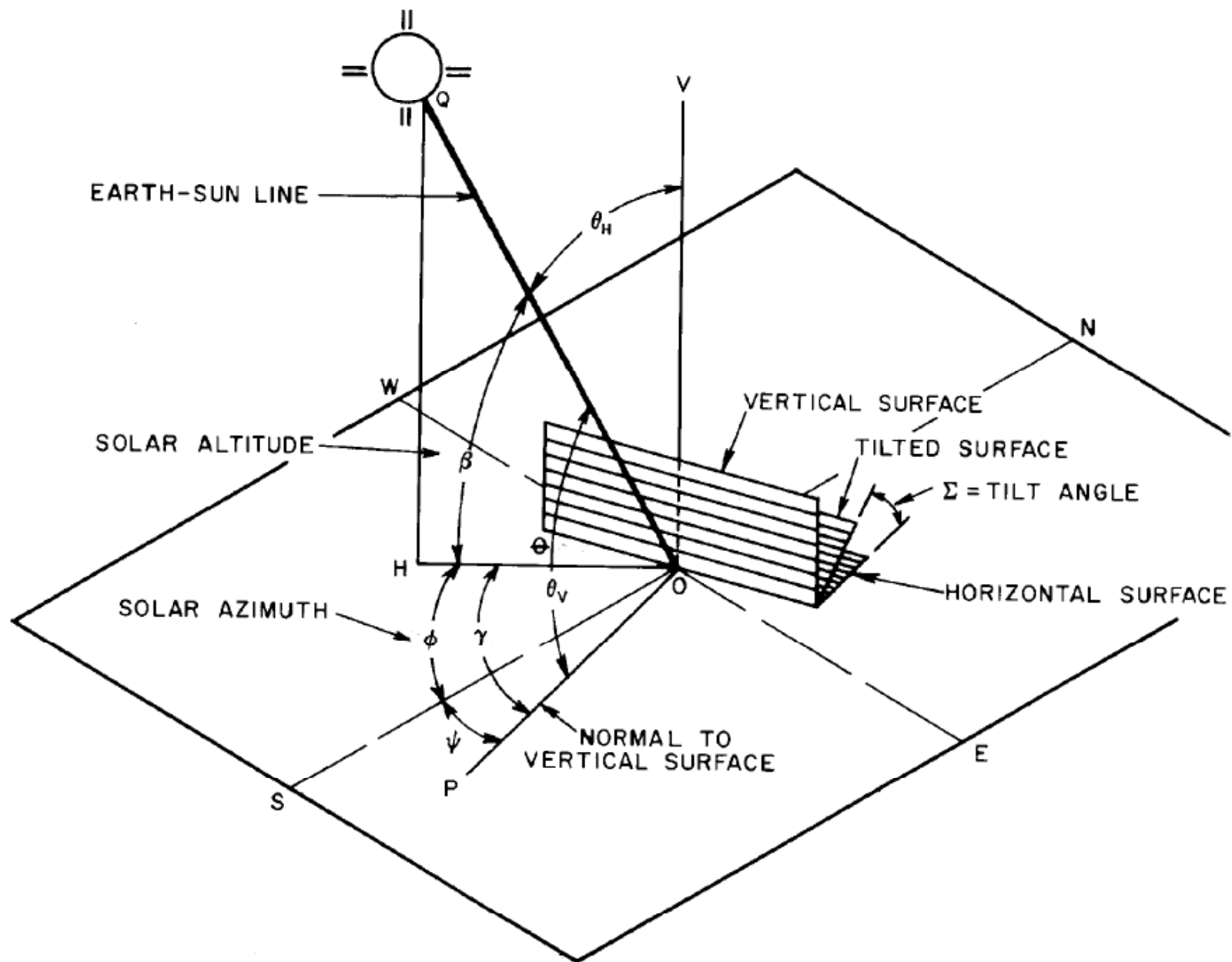

Fig. 10 Solar Angles for Vertical and Horizontal Surfaces

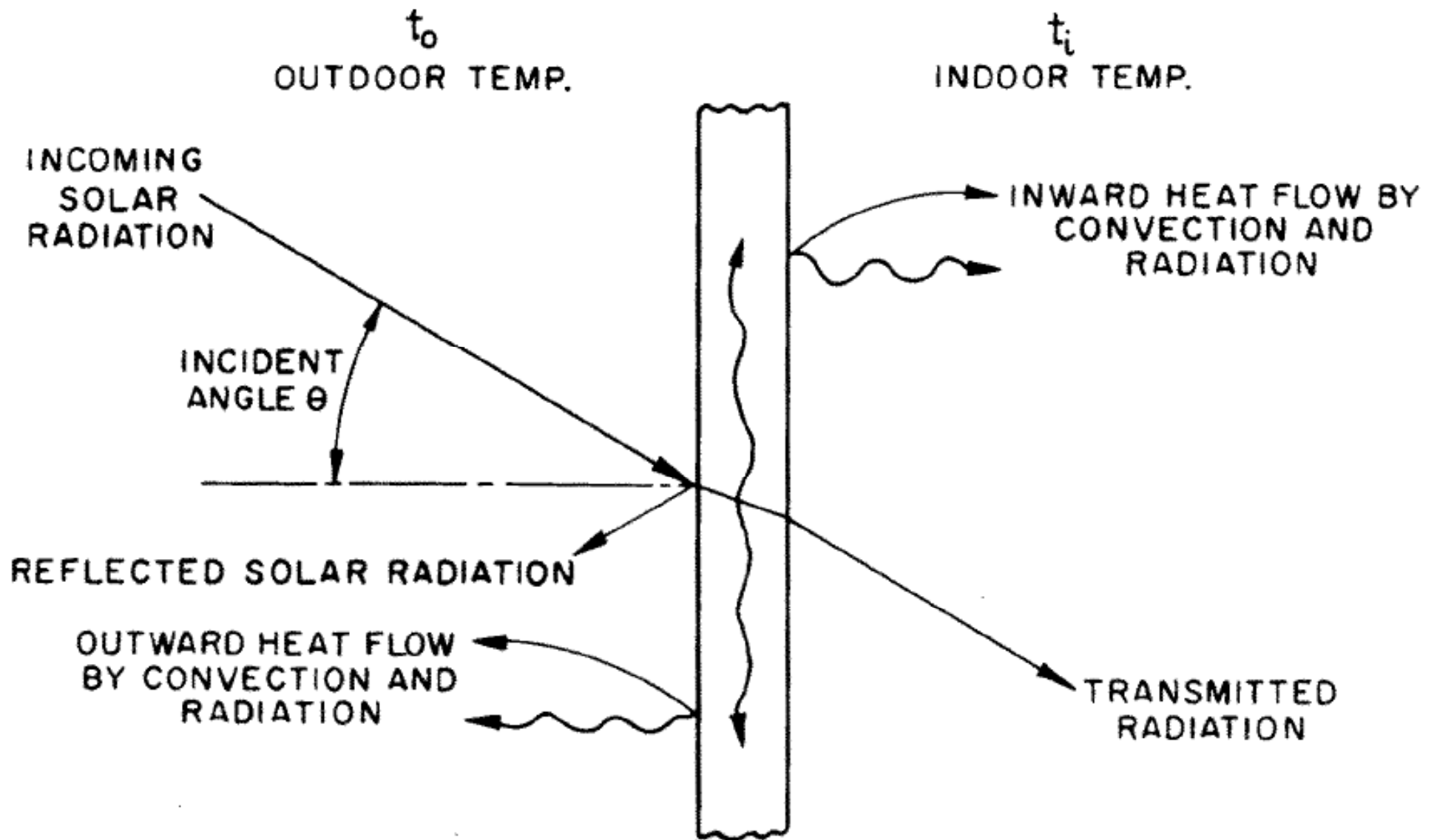
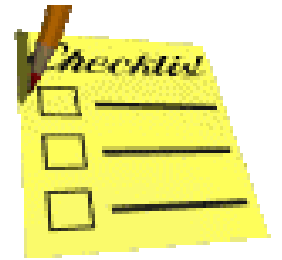
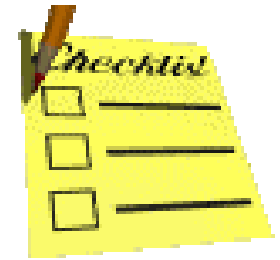

Fig. 26 Instantaneous Heat Balance for Sunlit Glazing Material

Cooling Load Components



- Cooling load calculation method
 - Example: CLTD/SCL/CLF method
 - It is a one-step, simple calculation procedure developed by ASHRAE
 - CLTD = cooling load temperature difference
 - SCL = solar cooling load
 - CLF = cooling load factor
 - See ASHRAE Handbook Fundamentals for details
 - Tables for CLTD, SCL and CLF



Cooling Load Components

- External
 - Roofs, walls, and glass conduction
 - $q = U A$ (CLTD) $U = U\text{-value}; A = \text{area}$
 - Solar load through glass
 - $q = A (SC)$ (SCL) SC = shading coefficient
 - For unshaded area and shaded area
 - Partitions, ceilings, floors
 - $q = U A (t_{\text{adjacent}} - t_{\text{inside}})$

Cooling Load Components

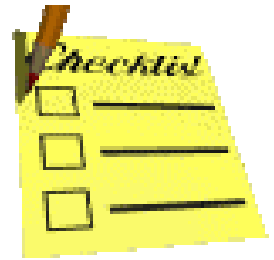

- Internal
 - People
 - $q_{\text{sensible}} = N$ (Sensible heat gain) (CLF)
 - $q_{\text{latent}} = N$ (Latent heat gain)
 - Lights
 - $q = \text{Watt} \times F_{\text{ul}} \times F_{\text{sa}}$ (CLF)
 - F_{ul} = lighting use factor; F_{sa} = special allowance factor
 - Appliances
 - $q_{\text{sensible}} = q_{\text{input}} \times \text{usage factors}$ (CLF)
 - $q_{\text{latent}} = q_{\text{input}} \times \text{load factor}$ (CLF)

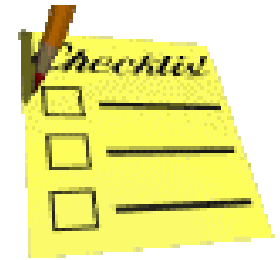

Cooling Load Components

- Ventilation and infiltration air
 - $q_{\text{sensible}} = 1.23 Q (t_{\text{outside}} - t_{\text{inside}})$
 - $q_{\text{latent}} = 3010 Q (w_{\text{outside}} - w_{\text{inside}})$
 - $q_{\text{total}} = 1.2 Q (h_{\text{outside}} - h_{\text{inside}})$
- System heat gain
 - Fan heat gain
 - Duct heat gain and leakage
 - Ceiling return air plenum

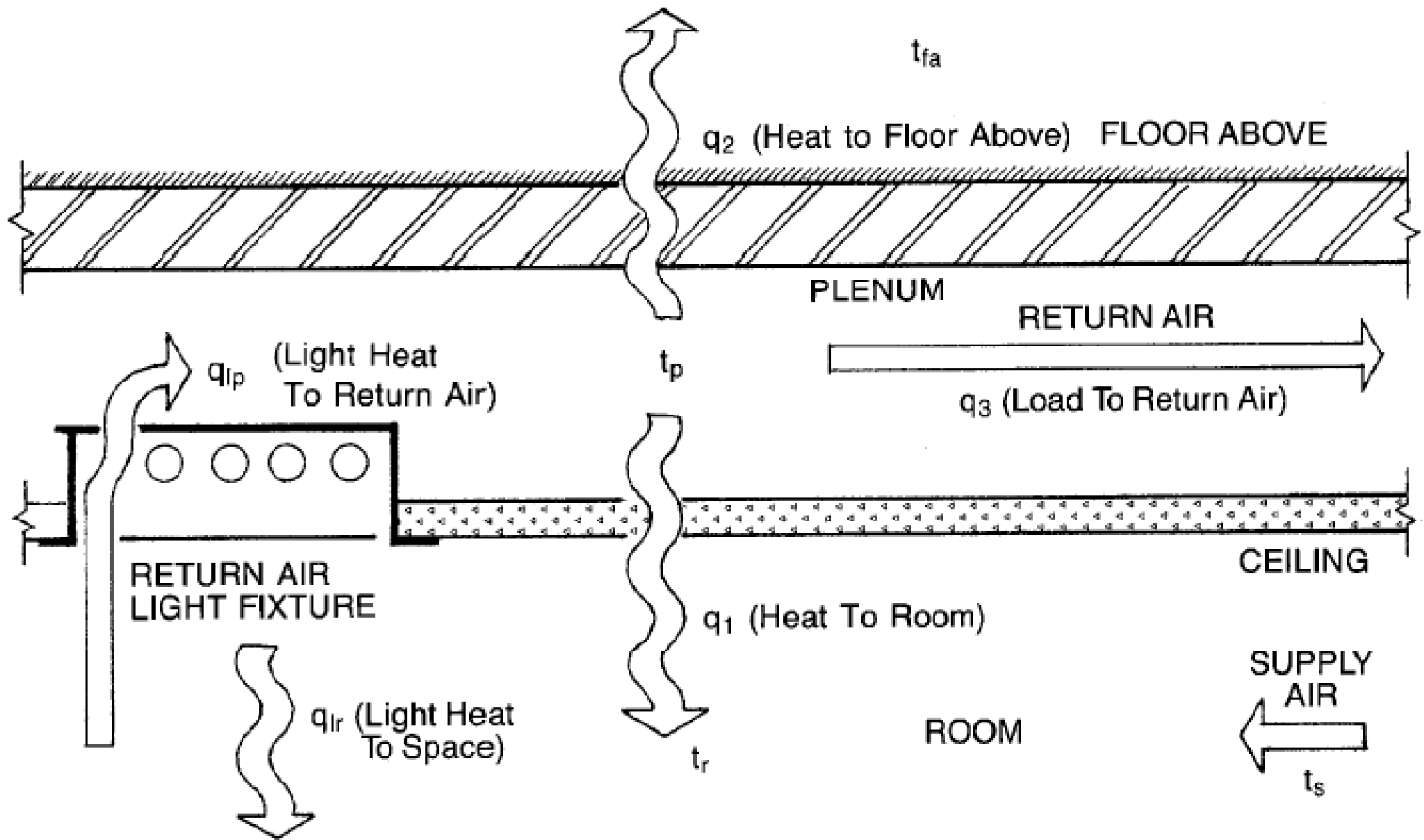

Schematic diagram of typical return air plenum

Cooling Load Principles

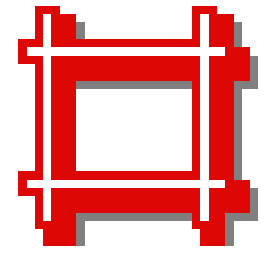

- Terminology:
 - Space – a volume w/o a partition, or a partitioned room, or group of rooms
 - Room – an enclosed space (a single load)
 - Zone – a space, or several rooms, or units of space having some sort of coincident loads or similar operating characteristics
 - Thermal zoning

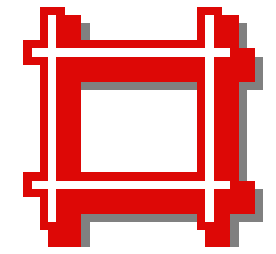

Cooling Load Principles

- Definitions
 - Space heat gain: instantaneous rate of heat gain that enters into or is generated within a space
 - Space cooling load: the rate at which heat must be removed from the space to maintain a constant space air temperature
 - Space heat extraction rate: the actual rate of heat removal when the space air temp. may swing
 - Cooling coil load: the rate at which energy is removed at a cooling coil serving the space

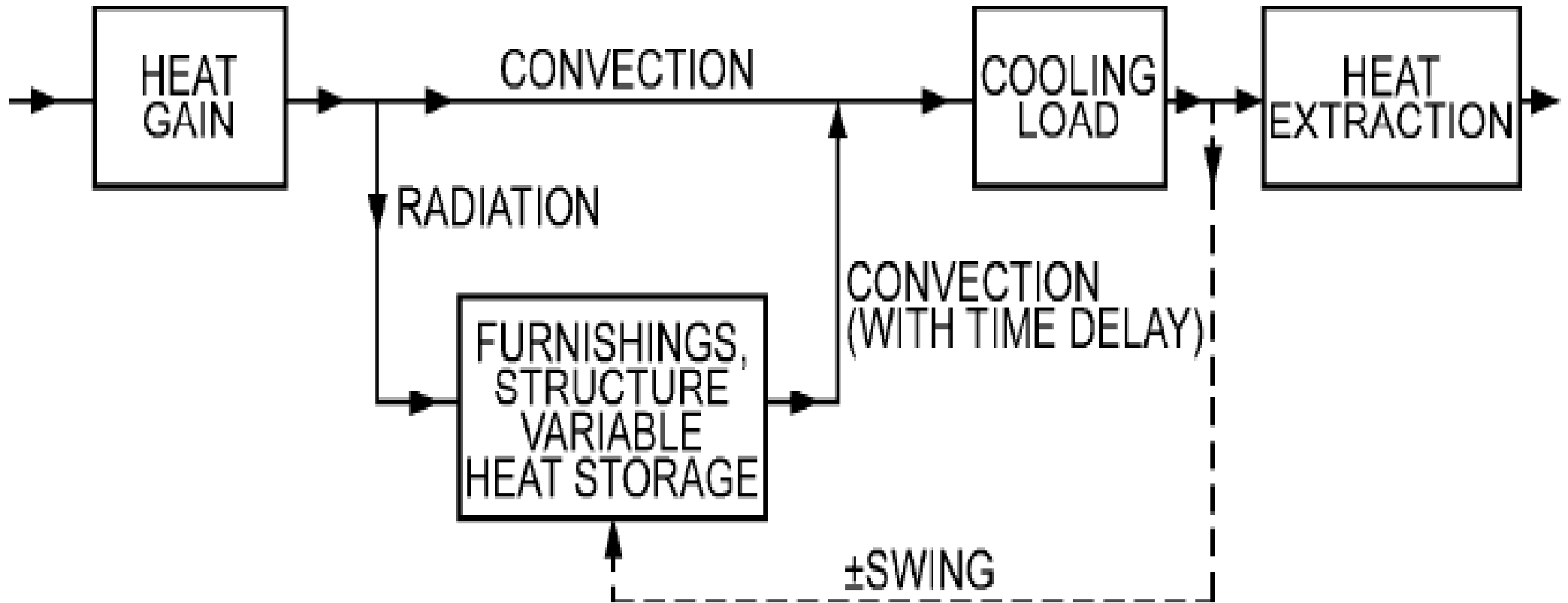

Conversion of heat gain into cooling load

Cooling Load Principles

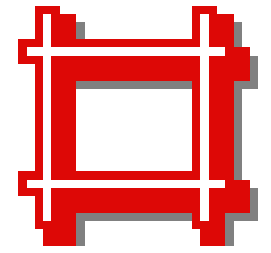

- Instantaneous heat gain vs space cooling loads
 - They are NOT the same
- Effect of heat storage
 - Night shutdown period
 - HVAC is switched off. What happens to the space?
 - Cool-down or warm-up period
 - When HVAC system begins to operate
 - Need to cool or warm the building fabric
 - Conditioning period
 - Space air temperature within the limits

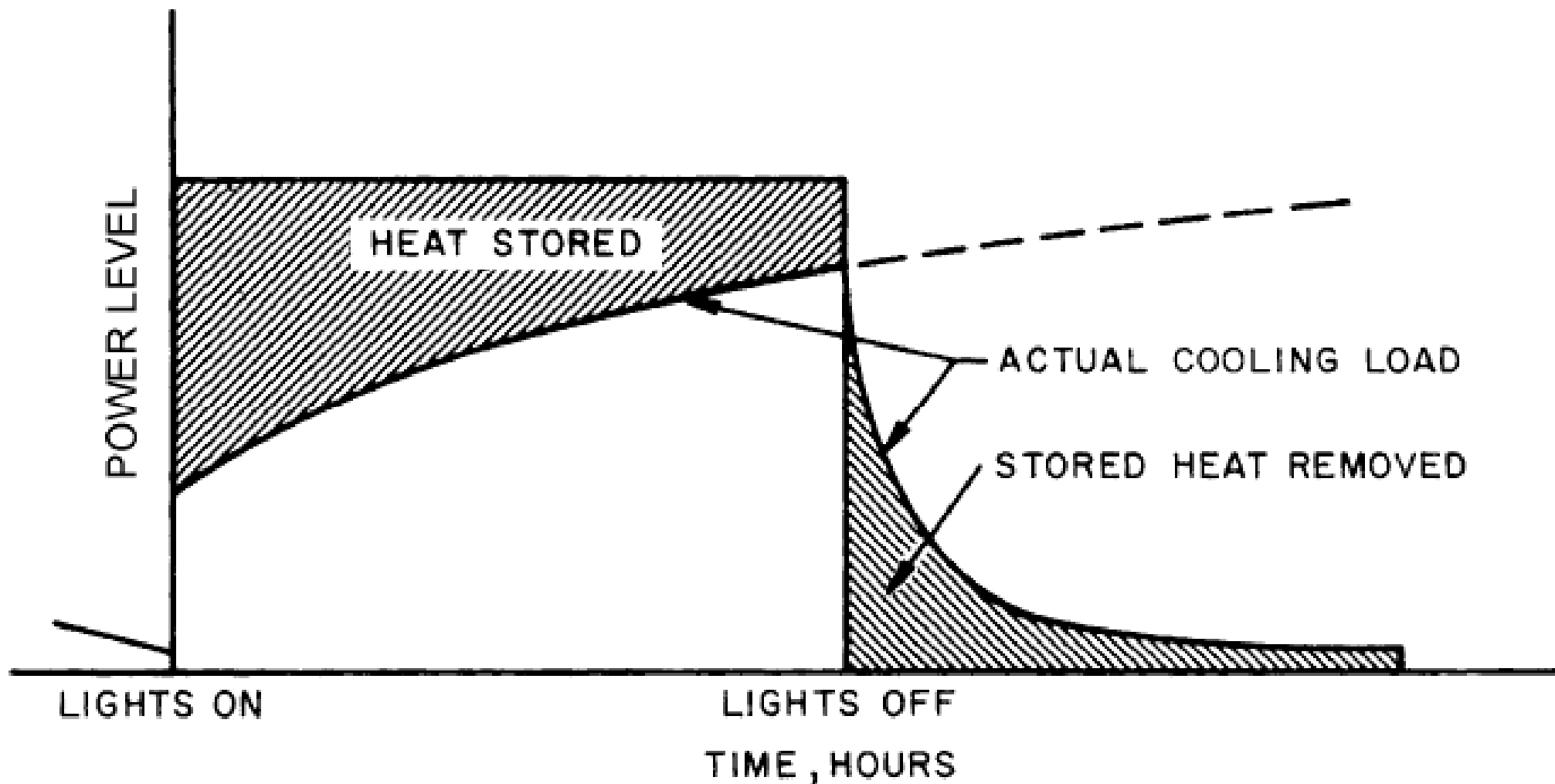

Thermal Storage Effect in Cooling Load from Lights

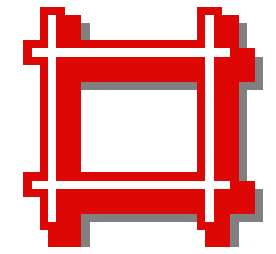

Cooling Load Principles

- Space load and equipment load
 - Space heat gain (sensible, latent, total)
 - Space cooling / heating load [*at building*]
 - Space heat extraction rate
 - Cooling / heating coil load [*at air-side system*]
 - Refrigeration load [*at the chiller plant*]
- Instantaneous heat gain
 - Convective heat
 - Radiative heat (heat absorption)

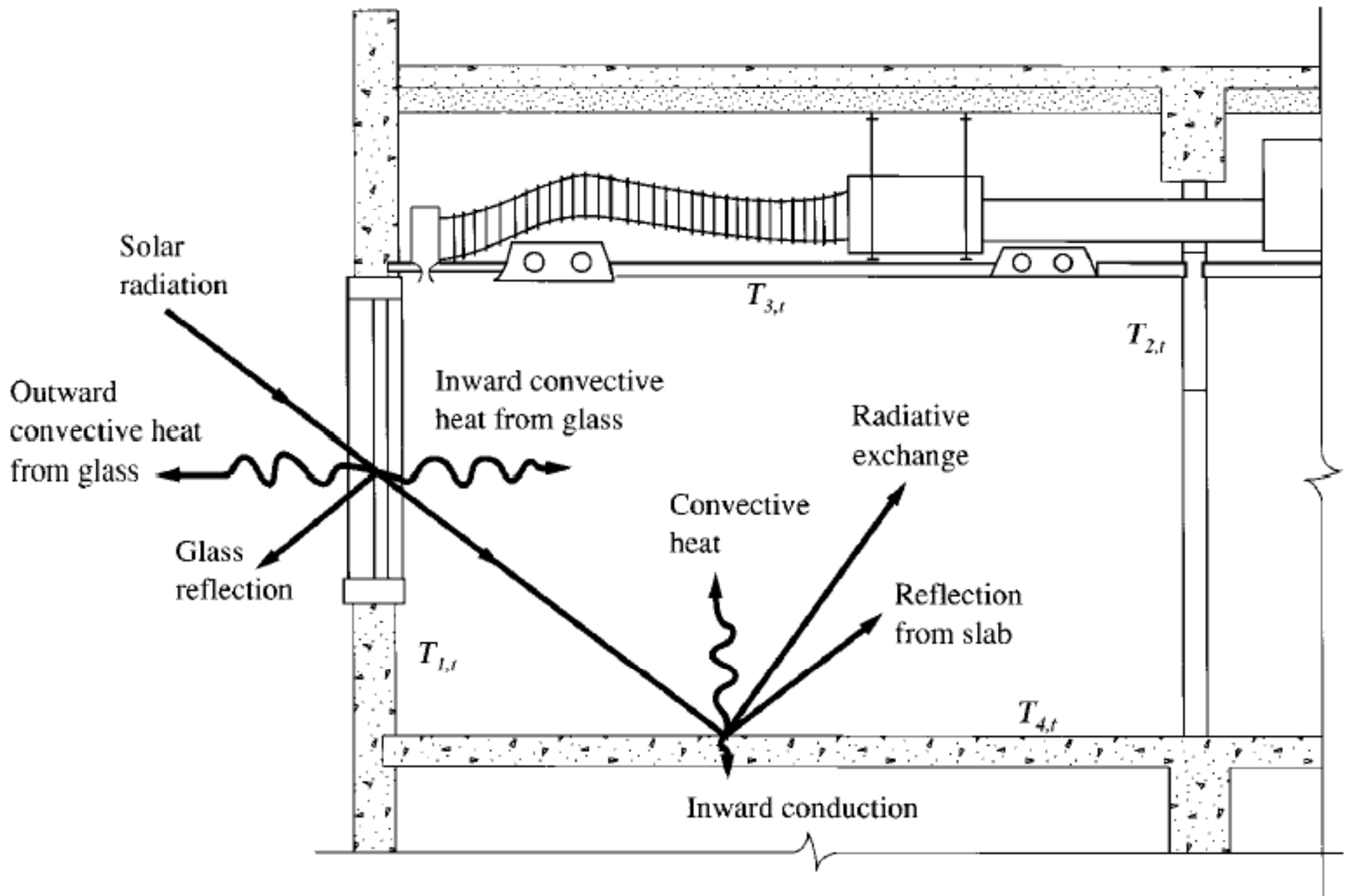

Convective and radiative heat in a conditioned space

Sensible heat gains	Convective (%)	Radiative (%)
Solar radiation with internal shading	42	58
Fluorescent lights	50	50
Occupants	67	33
External wall, inner surface	40	60

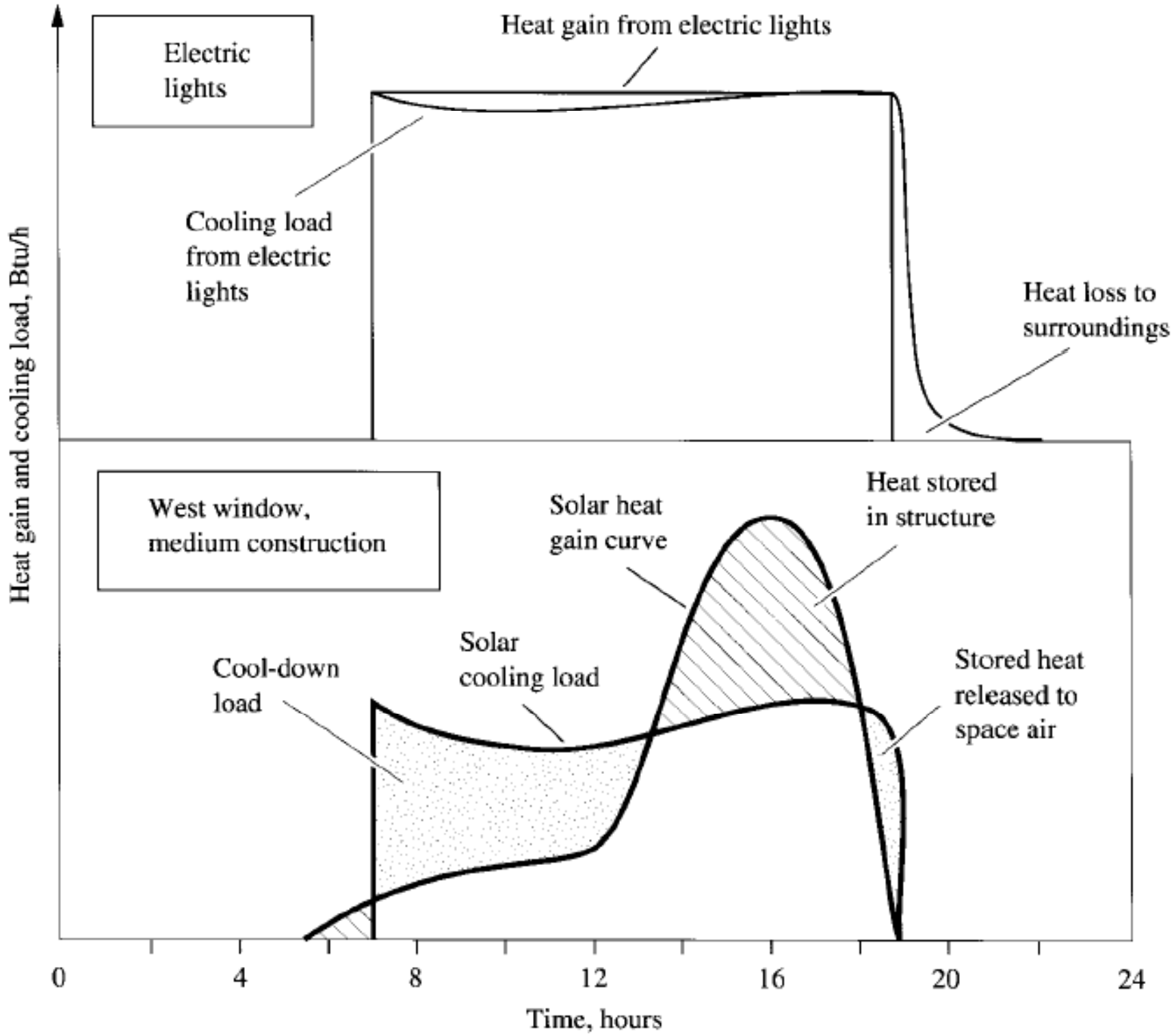

(Source: Wang, S. K., 2001. *Handbook of Air Conditioning and Refrigeration*, 2nd ed.)

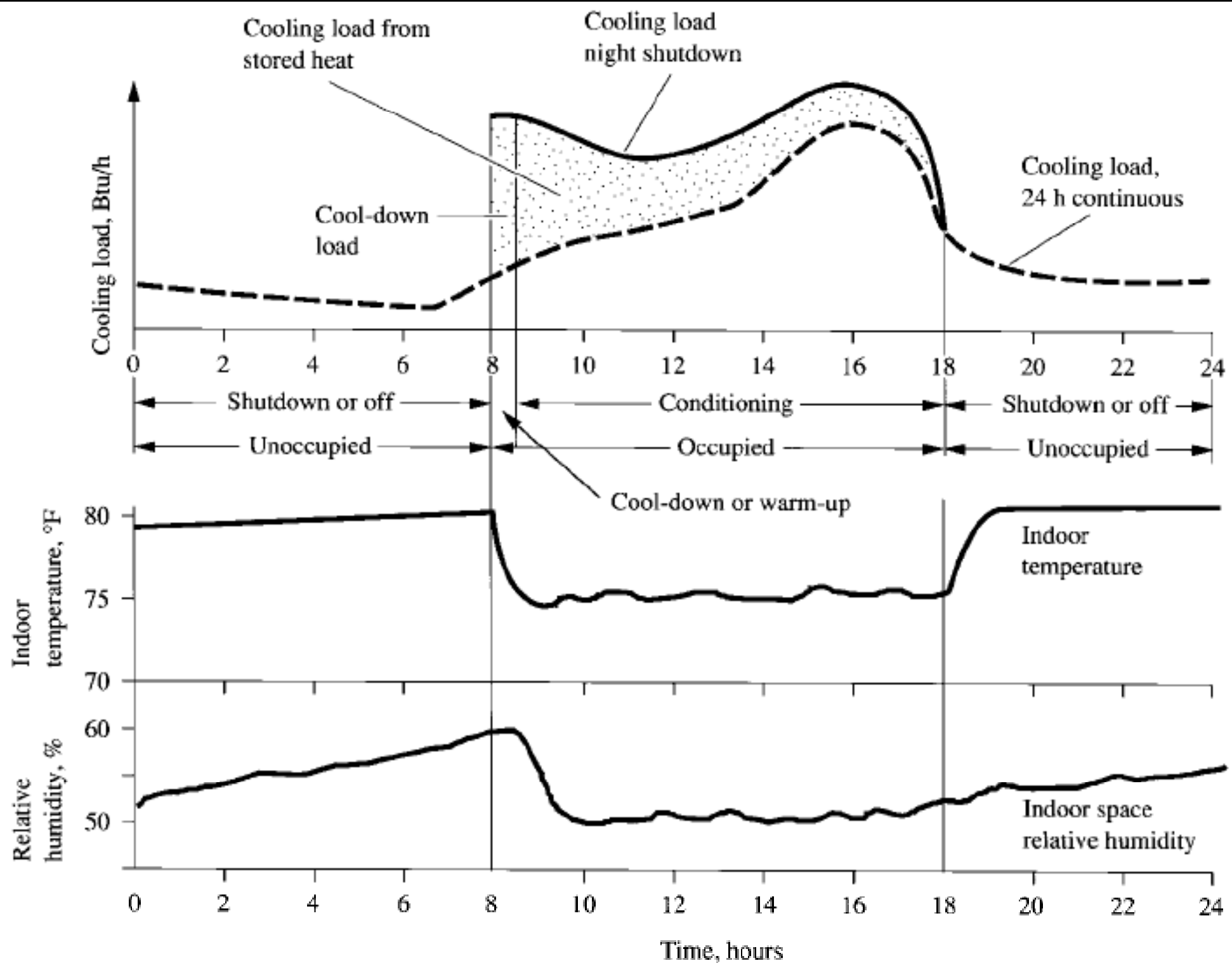

(Source: Wang, S. K., 2001. *Handbook of Air Conditioning and Refrigeration*, 2nd ed.)

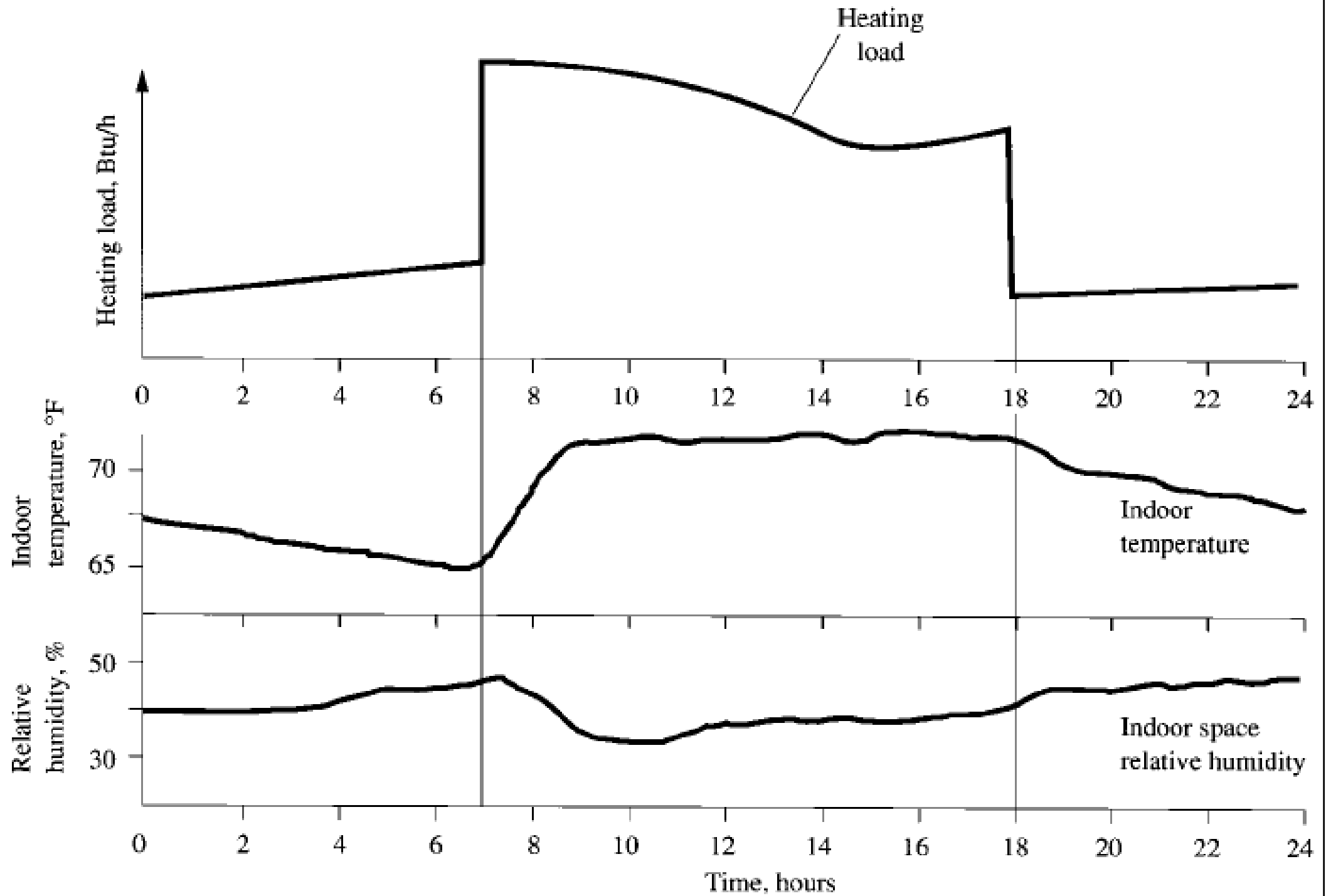

(Source: Wang, S. K., 2001. *Handbook of Air Conditioning and Refrigeration*, 2nd ed.)

Cooling Load Principles

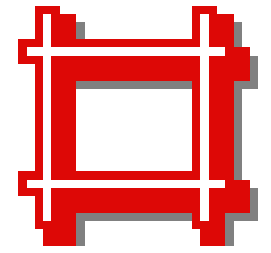

- Cooling load profiles
 - Shows the variation of space cooling load
 - Such as 24-hr cycle
 - Useful for building operation & energy analysis
 - What factors will affect load profiles?
- Peak load and block load
 - Peak load = max. cooling load
 - Block load = sum of zone loads at a specific time

Cooling load profiles

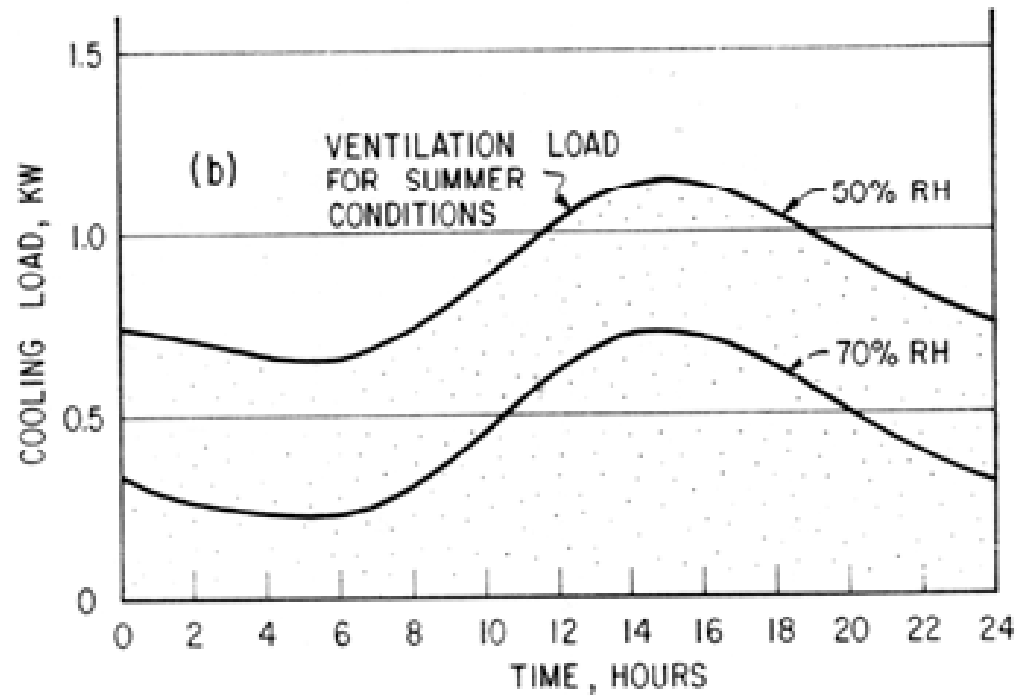
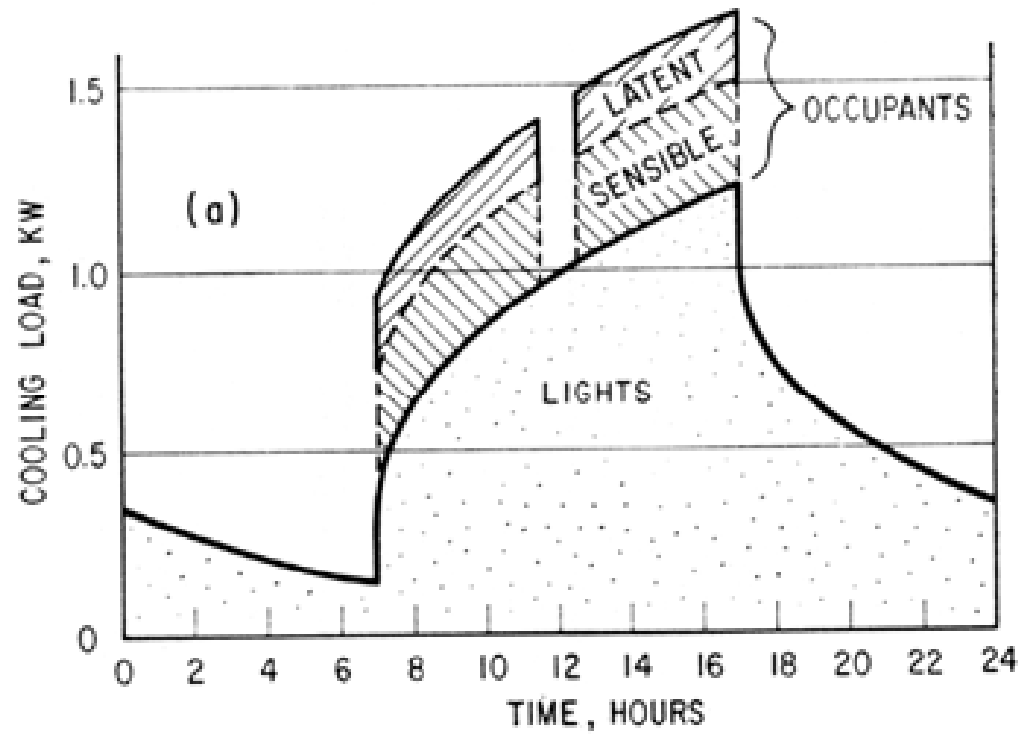

Total cooling load

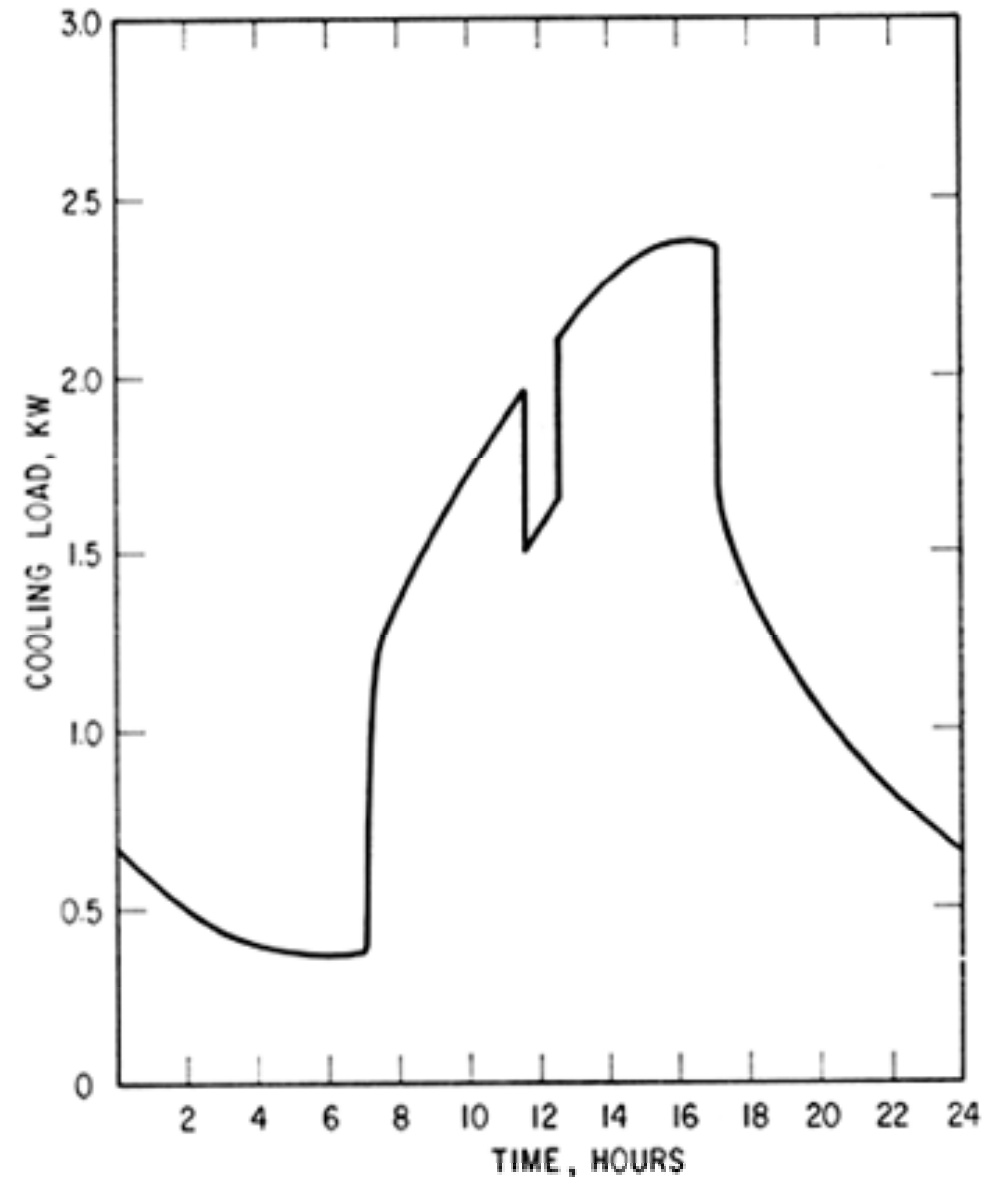

North

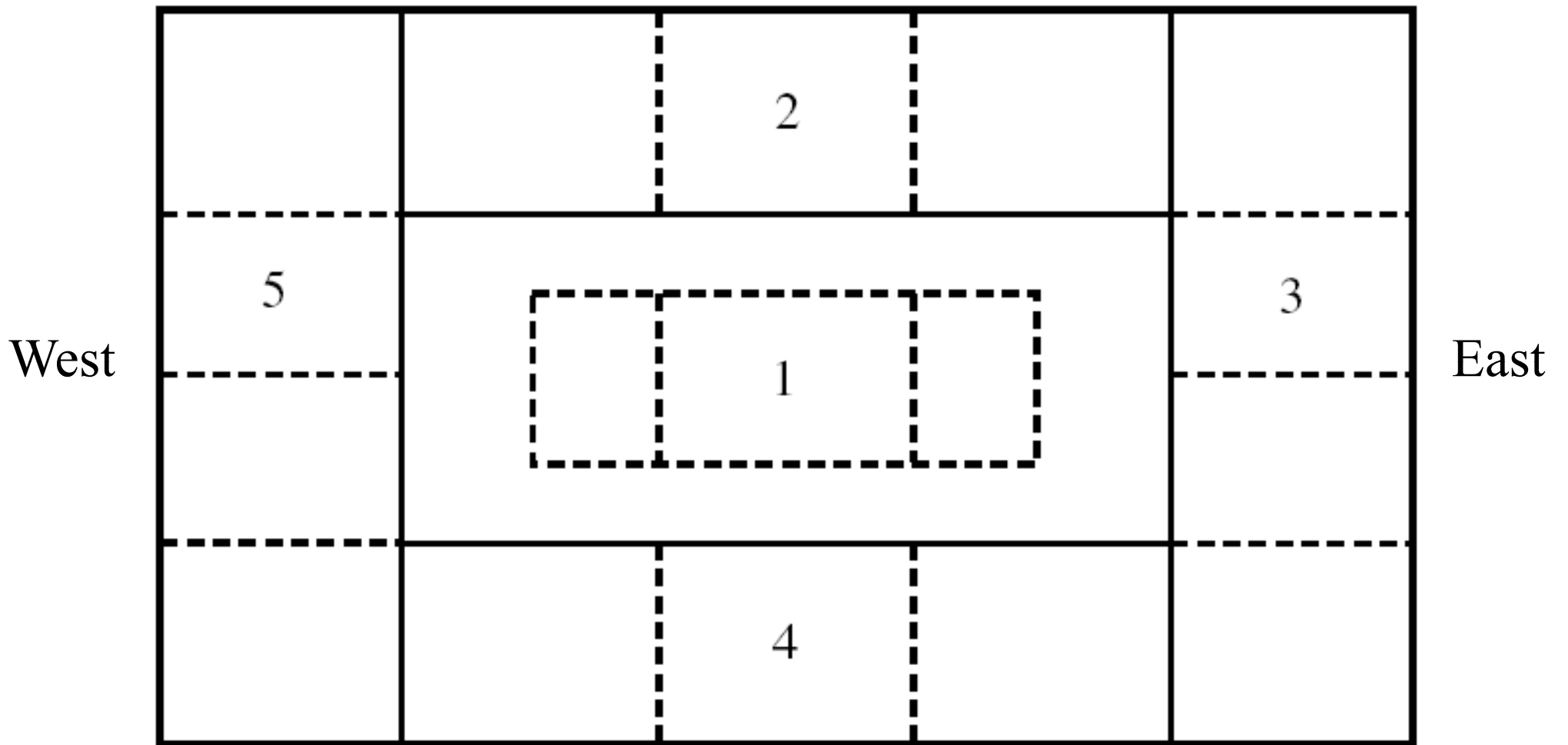

South

Block load and thermal zoning

Cooling loads due to windows at different orientations

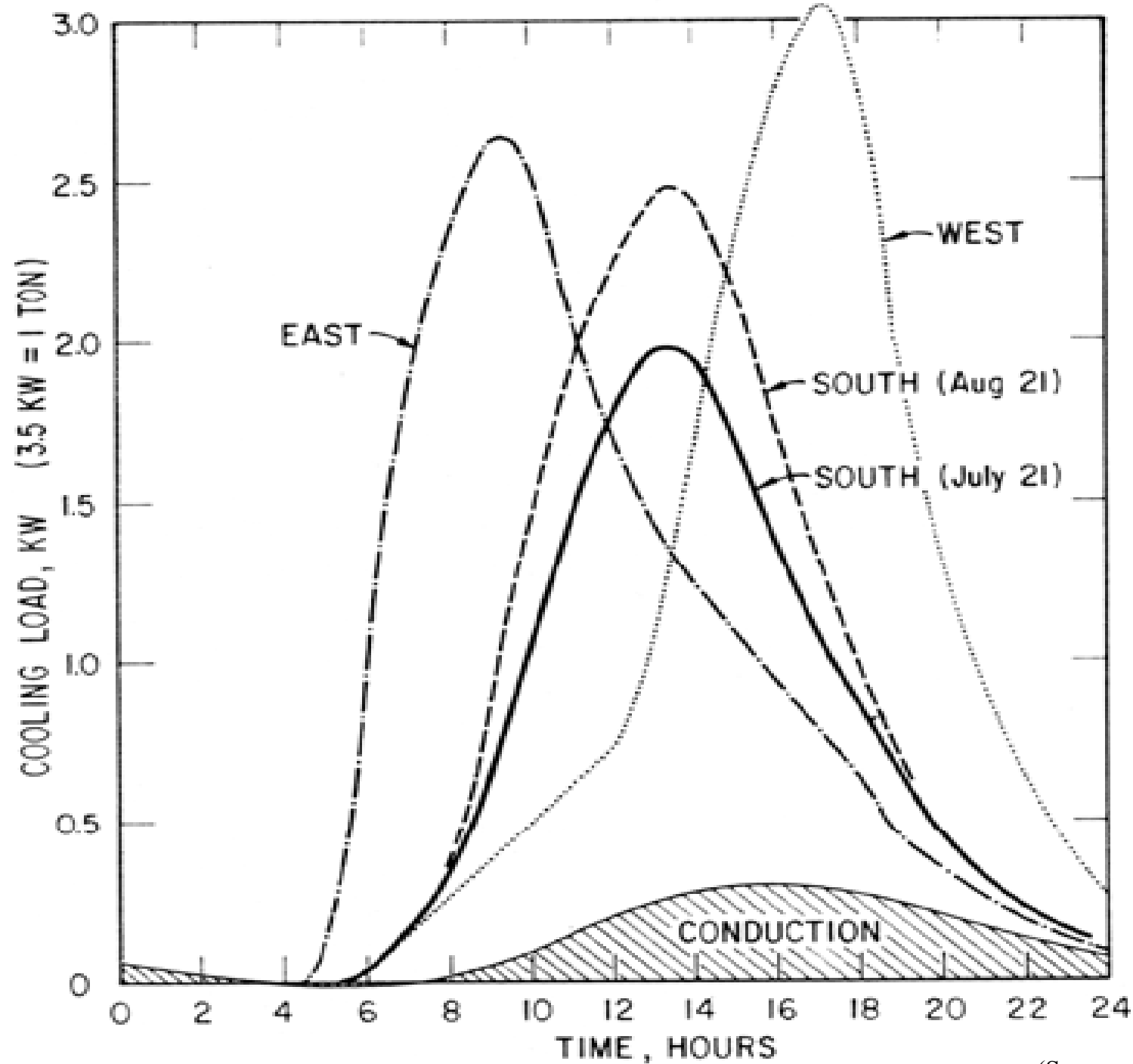

(Source: D.G. Stephenson, 1968)

Profiles of solar heat gain (July) (for latitude 48 deg N)

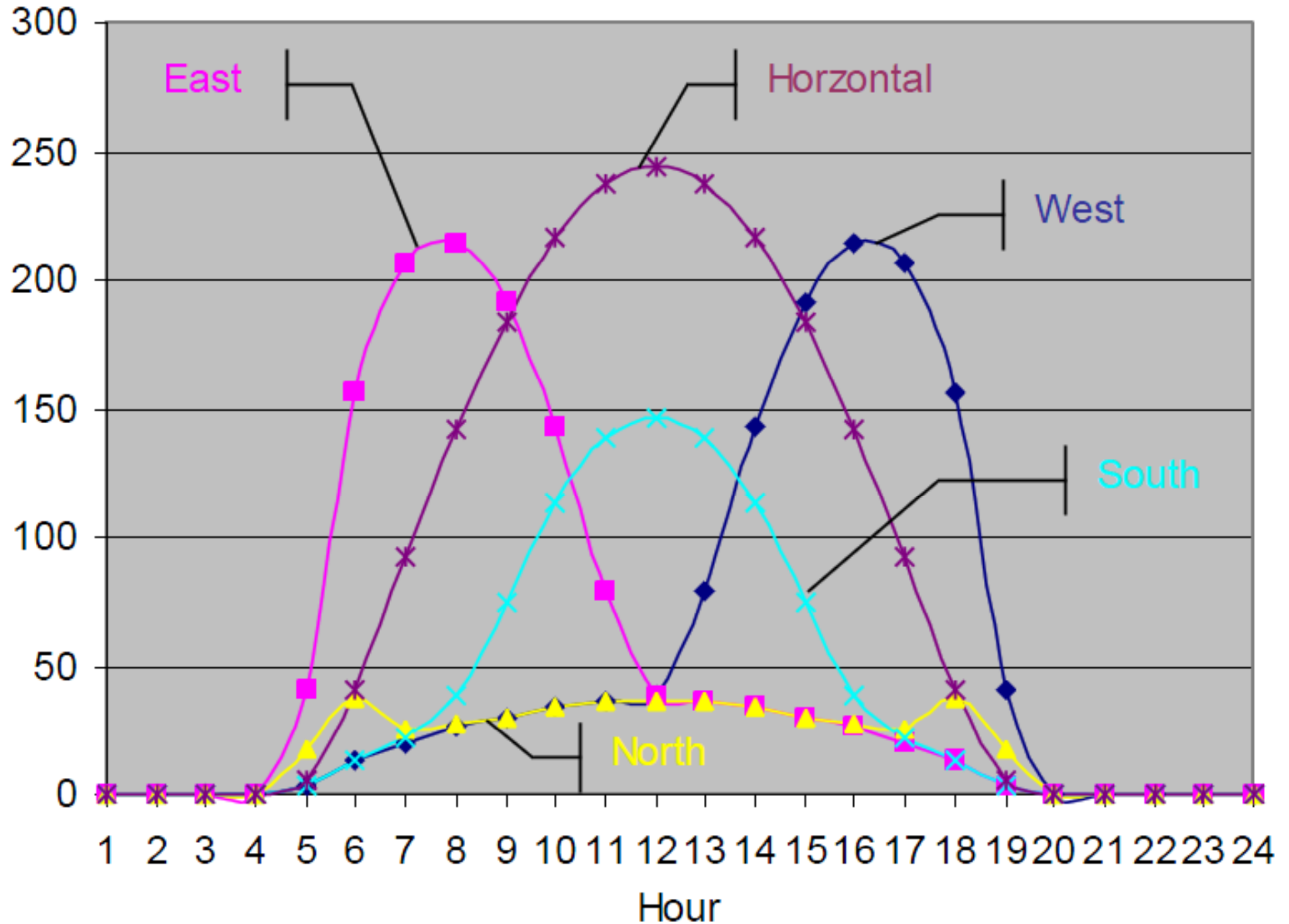

Solar cooling load vs. heat gain (July, west) (latitude 48 deg N)

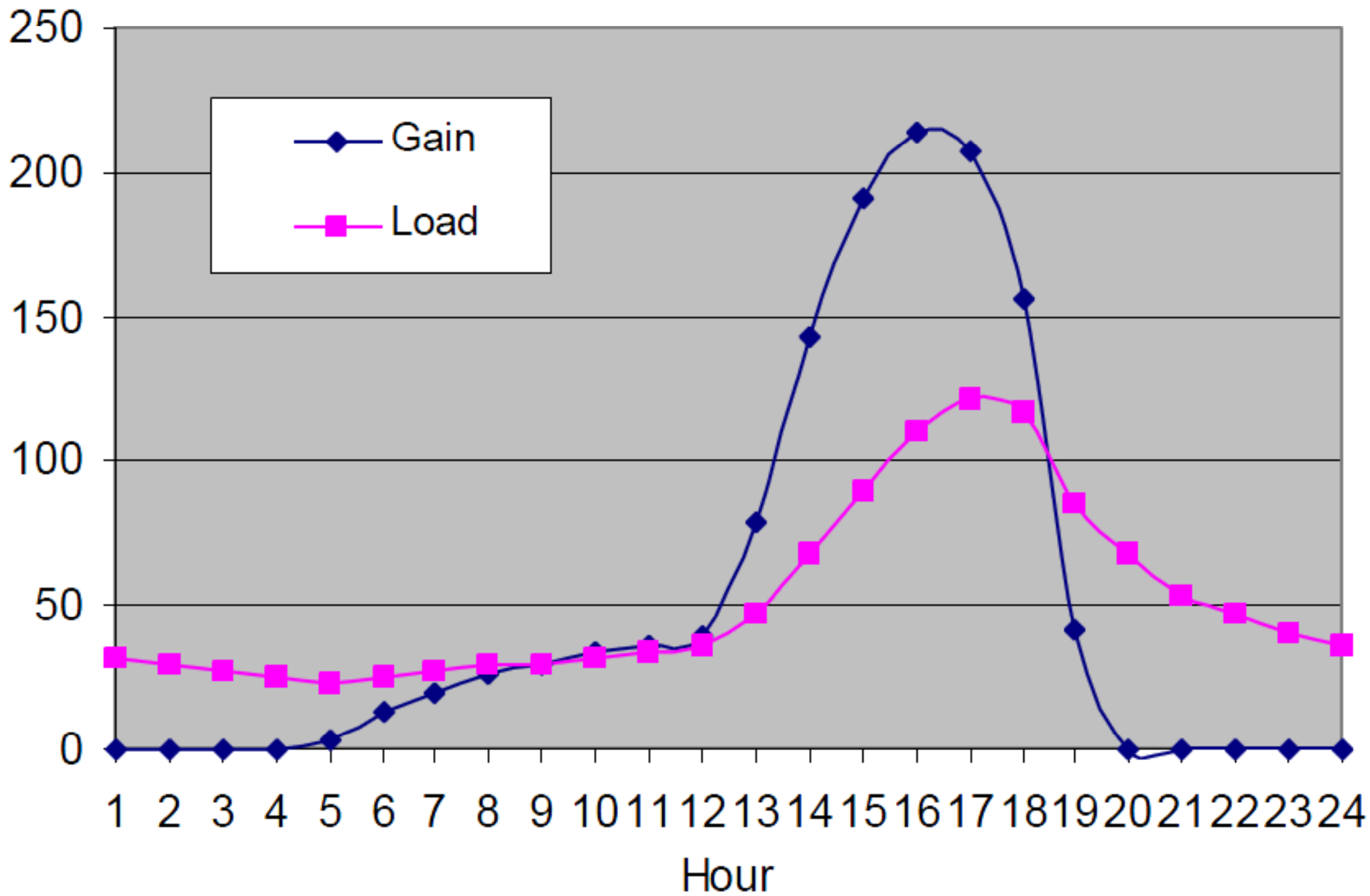

(Source: Keith E. Elder)

Cooling Load Principles

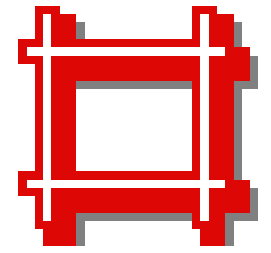

- Moisture transfer
 - Two paths:
 - Moisture migrates in building envelope
 - Air leakage (infiltration or exfiltration)
 - If slight RH variation is acceptable, then storage effect of moisture can be ignored
 - Latent heat gain = latent cooling load (instantaneously)
- What happens if both temp. & RH need to be controlled?



Cooling Coil Load

- Cooling coil load consists of:
 - Space cooling load (sensible & latent)
 - Supply system heat gain (fan + air duct)
 - Return system heat gain (plenum + fan + air duct)
 - Load due to outdoor ventilation rates (or ventilation load)
- Do you know how to construct a summer air conditioning cycle on a psychrometric chart?
 - See also notes in Psychrometrics



Cooling Coil Load

- Space cooling load $\text{Supply airflow (L/s)} = \frac{\text{Sensible load (kW)}}{1.2 \times \Delta t}$
 - To determine supply air flow rate & size of air system, ducts, terminals, diffusers
 - It is a component of cooling coil load
 - Infiltration heat gain is an instant. cooling load
- Cooling coil load
 - To determine the size of cooling coil & refrigeration system
 - Remember, ventilation load is a coil load

Heating Load

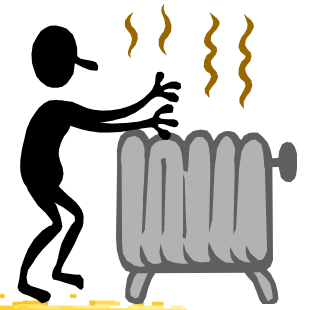

- Design heating load

- Max. heat energy required to maintain winter indoor design temp.
 - Usually occurs before sunrise on the coldest days
 - Include transmission losses & infiltration/ventilation
- Assumptions:
 - All heating losses are instantaneous heating loads
 - Credit for solar & internal heat gains is not included
 - Latent heat often not considered (unless w/ humidifier)
 - Thermal storage effect of building structure is ignored

Heating Load

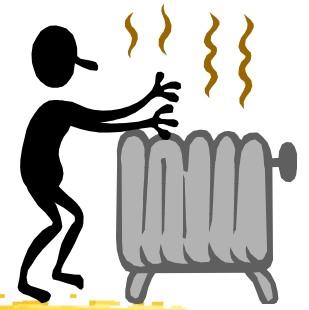

- A simplified approach to evaluate worst-case conditions based on
 - Design interior and exterior conditions
 - Including infiltration and/or ventilation
 - No solar effect (at night or on cloudy winter days)
 - Before the presence of people, light, and appliances has an offsetting effect
- Also, a warm-up/safety allowance of 20-25% is fairly common

Table 12 Summary of Loads, Equations, and References for Calculating Design Heating Loads

Heating Load	Equation	Reference, Table, Description
Roofs, ceilings, walls, glass	$q = U A \Delta t$	<p>Chapter 24, Tables 1, 2, and 4</p> <p>Temperature difference between inside and outside design dry bulbs, Chapter 26. For temperatures in unheated spaces, see Equation (2); for attic temperatures, see Equation (3).</p> <p>Area calculated from plans</p>
Walls below grade	$q = U A \Delta t$	<p>See Table 14.</p> <p>Use Figure 6 to assist in determining Δt.</p>
Floors Above grade	$q = U A \Delta t$	<p>For crawl space temperatures, see Equation (4).</p>
On grade	$q = F_2 P \Delta t$	<p>See Table 16.</p> <p>See Equation (6).</p> <p>Perimeter of slab</p>
Below grade	$q = U A \Delta t$	<p>Use Figure 6 to assist in determining Δt.</p> <p>See Table 15.</p>
Infiltration and ventilation air		<p>Volume of outdoor air entering building. See Chapter 25 for estimating methods for infiltration.</p>
Sensible	$q_s = 0.018 Q \Delta t$	
Latent	$q_l = 80.7 Q \Delta W$	<p>Humidity ratio difference, if humidification is to be added</p>

Software Applications

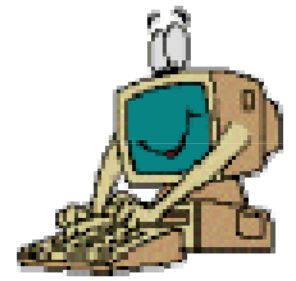

- Commonly used cooling load software
 - TRACE 600/700 and Carrier E20-II
 - Commercial programs from Trane and Carrier
 - Most widely used by engineers
 - DOE-2 (used more for research)
 - Also a detailed building energy simulation tool

Software Applications

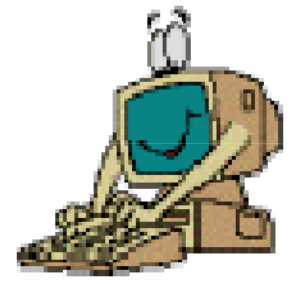

- Software demonstration
 - TRACE 700
 - TRACE = Trane Air Conditioning Economics
 - Building load and energy analysis software
 - Demon version can be downloaded
 - <http://www.trane.com/commercial/>

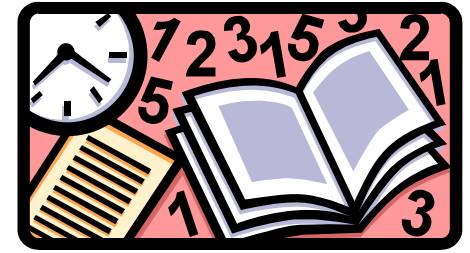

References

- Air Conditioning and Refrigeration Engineering (Wang and Norton, 2000)
 - Chapter 6 – Load Calculations
- ASHRAE Handbook Fundamentals (2009 edition)
 - Chapter 14 – Climatic Design Information
 - Chapter 15 – Fenestration
 - Chapter 17 – Residential Cooling and Heating Load Calculations
 - Chapter 18 – Nonresidential Cooling and Heating Load Calculations

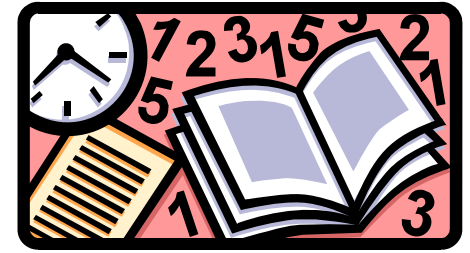

References

- Remarks:
 - “Load & Energy Calculations” in *ASHRAE Handbook Fundamentals*
 - The following previous cooling load calculations are described in earlier editions of the ASHRAE Handbook (1997 and 2001 versions)
 - CLTD/SCL/CLF method
 - TETD/TA method
 - TFM method