

MEBS6008 Environmental Services II

<http://www.hku.hk/bse/MEBS6008/>



Space Air Diffusion I



Dr. Sam C M Hui

Department of Mechanical Engineering

The University of Hong Kong

E-mail: cmhui@hku.hk

Sep 2010

Contents

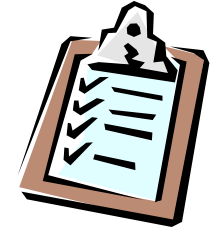

- Basic Principles
- Air Jets
- Outlets and Inlets
- Mixing Flow



Basic Principles

- Objective of space air diffusion
 - Evenly distribute conditioned & outdoor air to provide healthy & comfortable indoor environment, or appropriate environment for process, at optimum cost
- Last process of air conditioning
 - Take place entirely within conditioned space
 - Directly affect the occupants, but it is difficult to trace & quantify



Basic Principles

- Important considerations:
 - Thermal comfort (temp., humidity, air velocity)
 - Comfort conditions, local variations
 - Indoor air quality
 - Airborne pollutants
 - Ventilation effects
 - Noise control
 - Noise criteria, sound attenuation
- Occupied zone: 1.8 m from floor

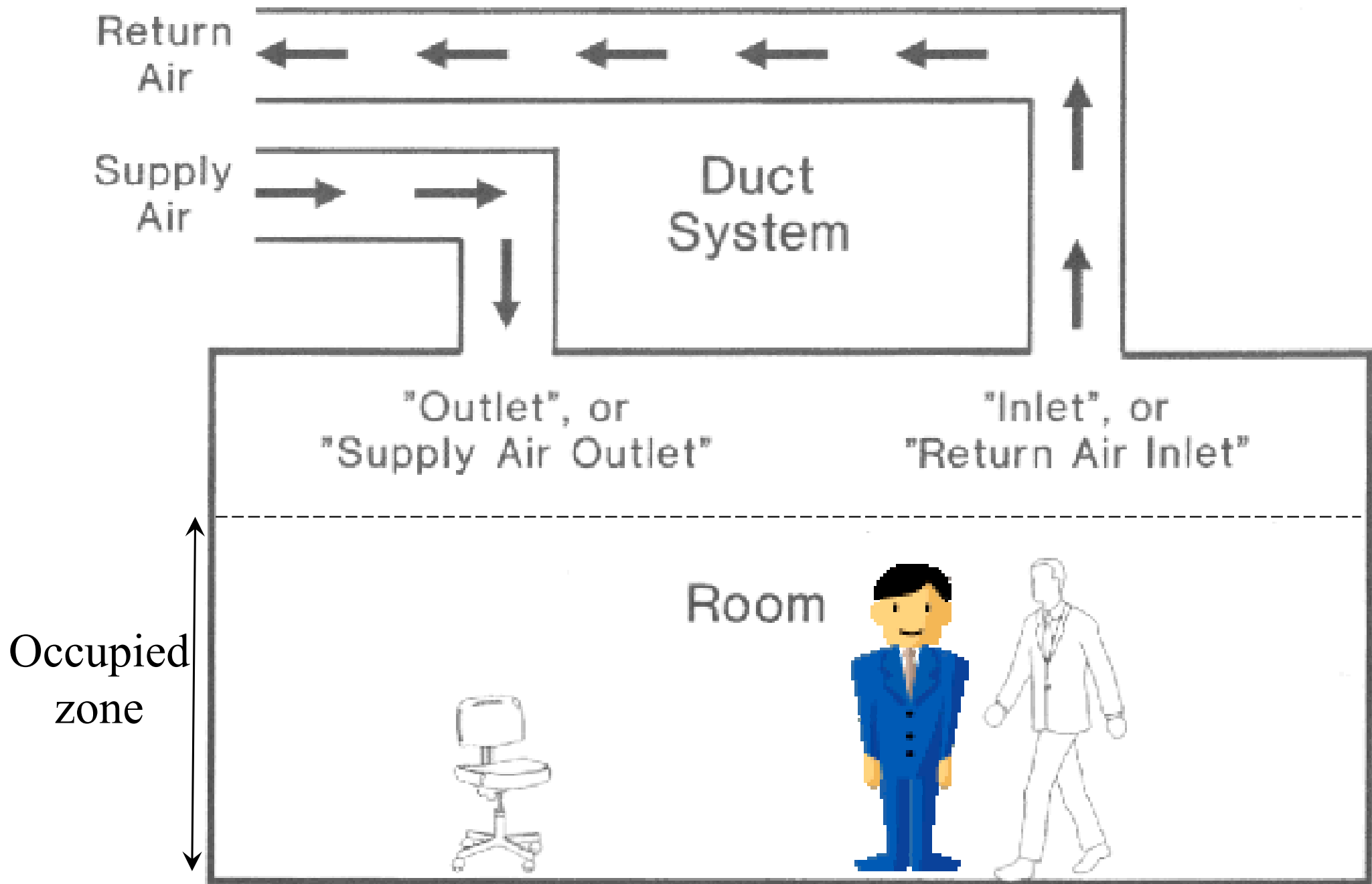

(Source: Rock, B. A. and Zhu, D., 2002. *Designer's Guide to Ceiling-based Air Diffusion*.)



Basic Principles

Thermal Comfort

- Draft & effective draft temperature

- Draft: unwanted local cooling of human body caused by air movement & lower space air temp.
- Turbulence intensity, $I_{\text{tur}} = \sigma_v / v_m$
 - σ_v = standard deviation of air velocity fluctuation (m/s)
 - v_m = mean air velocity (m/s)
- Effective draft temperature: combines effects of uneven space air temp. & air movement
 - $\theta = T_x - T_r - a (v_x - v_{rm})$

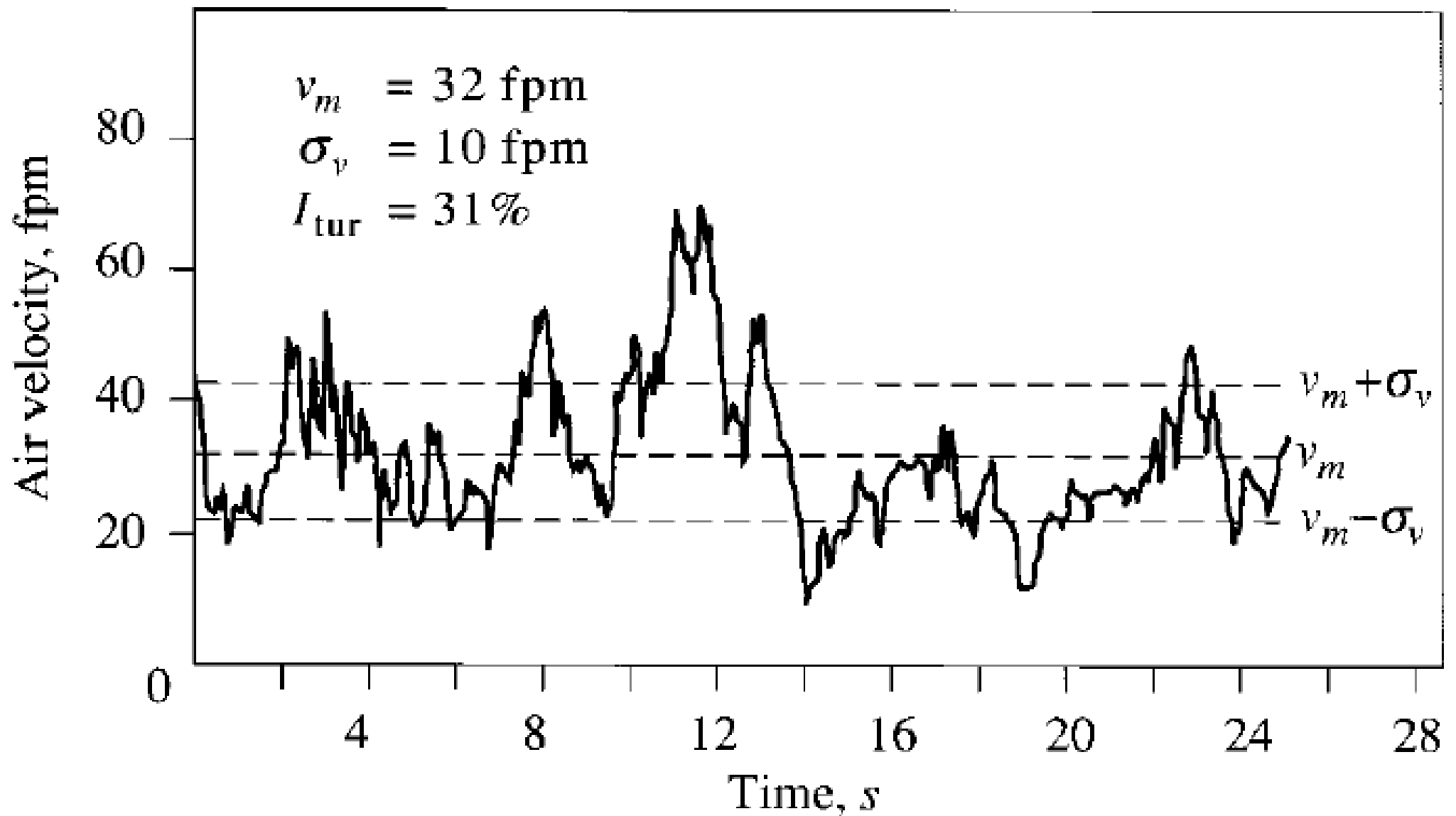

FIGURE 18.1 Fluctuations of air velocity in a typical air conditioned space. (Adapted with permission from *ASHRAE Journal*, April 1989, p. 30.)

(Source: Wang, S. K., 2001. *Handbook of Air Conditioning and Refrigeration*)

Basic Principles



- Air diffusion performance index (ADPI)
 - $ADPI = (N_{\theta} \times 100) / N$
 - θ : effective draft temperature
 - N_{θ} : number of points measured in occupied zone in which $-1.7 \text{ }^{\circ}\text{C} < \theta < 1.1 \text{ }^{\circ}\text{C}$
 - N : total number of points measured in occupied zone
 - Higher the ADPI, higher % of occupants who feel comfortable
 - ADPI is useful for cooling mode operation
 - For heating mode, temperature gradient % 2 points may be a better indicator of thermal comfort ($< 2.8 \text{ }^{\circ}\text{C}$ typical)



Basic Principles

- Air exchange rate
 - = Volume flow rate / interior volume
 - Unit: L/s or air change per hour (ACH)
 - May consider outside air, or supply air
- Time constant (τ)
 - Inverse of air exchange rate
- Air diffusion effectiveness
 - Perfectly mixing, perfectly displacing
 - Degree of effectiveness of air diffusion



Basic Principles

- Space diffusion effectiveness factor
 - For air temperature or air contamination

$$\varepsilon_T = \frac{T_{re} - T_s}{T_r - T_s} = \frac{T_{ex} - T_s}{T_r - T_s}$$

$$\varepsilon_C = \frac{C_{ex} - C_s}{C_r - C_s}$$

- Subscript: re = recirculating air; ex = exhaust air; r = space air; s = supply air
- Effective if $\varepsilon = 1$; not so if $\varepsilon < 1$



Basic Principles

- Ventilation effectiveness
 - Air system's ability to remove internally generated contaminants from a zone, space or building
- Age of air θ_{age} (in minutes or hours)
 - Time period that outdoor ventilation air has been in a zone, space or building
 - Evaluated using tracer gas method
 - The “youngest” air = freshest air



Basic Principles

- Air change effectiveness ε_N
 - Air system's ability to deliver ventilation air
 - How well outdoor air is diffused to various locations
 - $\varepsilon_N = \tau_N / \theta_{\text{age}, N}$
 - τ_N : nominal time constant (min. or hr.)
 - ACH = supply volume flow rate / space volume
 - $\tau_N = 1 / \text{ACH}$
 - For proper air distribution system, $\varepsilon_N \approx 1$

Air Jets



- Air jets
 - Airstream discharge from an outlet with significantly higher velocity than surrounding
 - Move along its centreline until terminal velocity reduces to velocity of ambient air
 - Envelope = outer boundary of air jet
 - Common classifications
 - Free or confined
 - Isothermal or non-isothermal
 - Axial or radial

Air Jets



- Air jets
 - Free air jet: envelope not confined by enclosure
 - Confined air jet: envelope confined by ceiling, floor, walls, windows, furniture, etc
 - Air jet approaches a free air jet if $\sqrt{A_r} / D_o > 50$
 - A_r = cross-sectional area of the enclosure perpendicular to the air jet centreline
 - D_o = diameter or circular equivalent of supply outlet
 - Isothermal jets: whose temperature is equal to the ambient air (c.f.: non-isothermal jets)

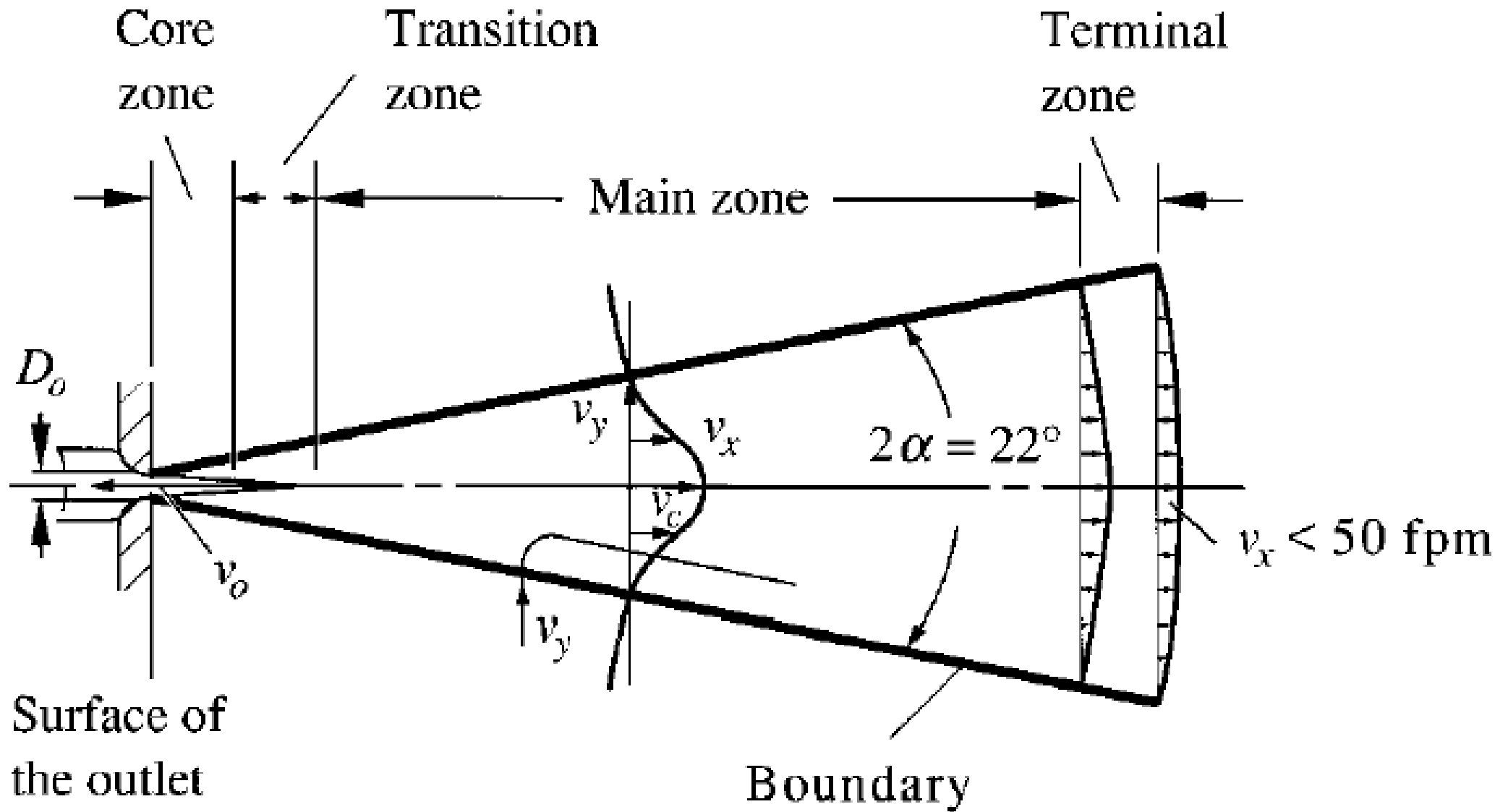

Four zones of a free, isothermal, axial air jet

(Source: Wang, S. K., 2001. Handbook of Air Conditioning and Refrigeration)

Air Jets



- Free isothermal jets
 - Core zone
 - Centreline velocity remains unchanged
 - Extends about $4 D_o$ from the outlet
 - Transition zone
 - Centreline velocity decreases inversely w/ square root of distance from outlet
 - Extends about $8 D_o$ from the outlet
 - Main zone
 - Turbulent flow is fully developed
 - Extends about $25-100 D_o$ from the outlet
 - Terminal zone
 - Max. air velocity decreases rapidly to less than 0.25 m/s

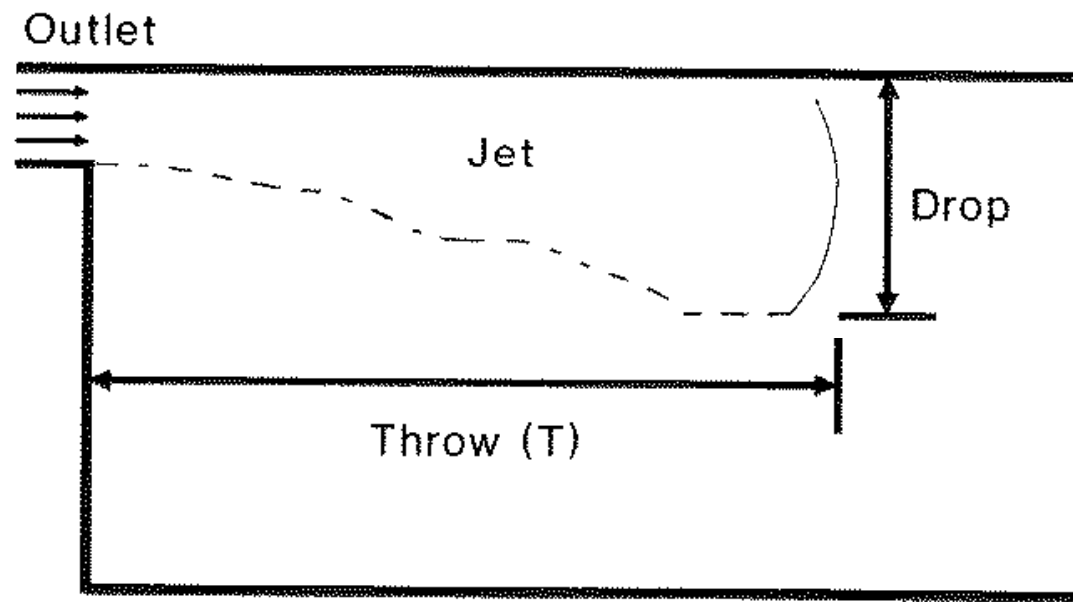

Section View

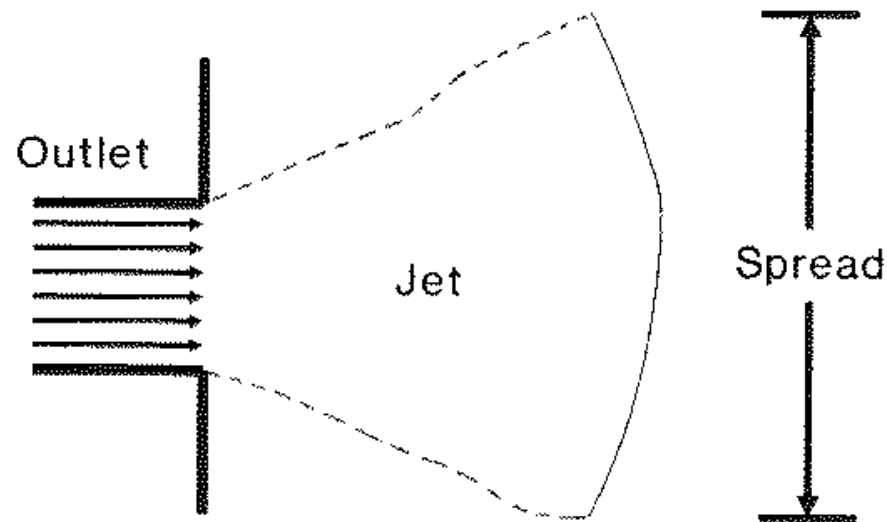

Plan View

(Source: Rock, B. A. and Zhu, D., 2002. *Designer's Guide to Ceiling-based Air Diffusion.*)

Air Jets



- Throw, T_v (m)

- Horizontal or vertical axial distance from outlet to a cross-sectional plane where max. velocity of airstream at the terminal zone has been reduced to 0.25, 0.5, or 0.75 m/s

$$T_v = \frac{K' \times \dot{V}_s}{v_{t,\max} \sqrt{A_c C_d R_{fa}}}$$

K' = centreline velocity constant

\dot{V}_s = supply volume flow rate

$v_{t,\max}$ = max. velocity at terminal zone

A_c = core area of outlet

C_d = discharge coefficient

R_{fa} = ratio of free area to gross area

Air Jets



- Entrainment ratio

- Ratio of volume flow rate to the total air at a specific cross-sectional plane of the air jet to volume flow rate of the supply air discharged from outlet (primary air)
- Total air = sum of supply air and induced air
- Proportional to the distance or square root of the distance from outlet

Air Jets



- Characteristic length, L
 - Horizontal distance from outlet to the nearest vertical opposite wall, or to the midplane between 2 outlets in the direction, OR the distance to the closest intersection of air jets
 - Ratio of T_v/L is related to ADPI of various supply outlets and has been used a parameter in space diffusion design

Table 3. Characteristic Length for Various Diffuser Types

Diffuser Type	Characteristic Length, L
High Sidewall Grille	Distance to wall perpendicular to jet
Circular Ceiling Diffuser	Distance to closest wall or intersecting air jet
Sill Grille	Length of room in the direction of the jet flow
Ceiling Slot Diffuser	Distance to wall or midplane between outlets
Light Troffer Diffusers	Distance to midplane between outlets, plus distance from ceiling to top of occupied zone
Perforated, Louvered Ceiling Diffusers	Distance to wall or midplane between outlets

Air Jets



- Confined air jets (in practical cases)
 - Surface effect (or Coanda effect)
 - Primary airstream from supply outlet flows along a surface (at high velocity)
 - A lower pressure region is formed near the surface
 - Induced ambient air presses the air jet to the surface
 - Friction between airstream & boundary
 - Decreases the centreline velocity of the air jets
 - With the surface effect, throw of a confined air jet is longer, drop from horizontal axis smaller than that of a free air jet

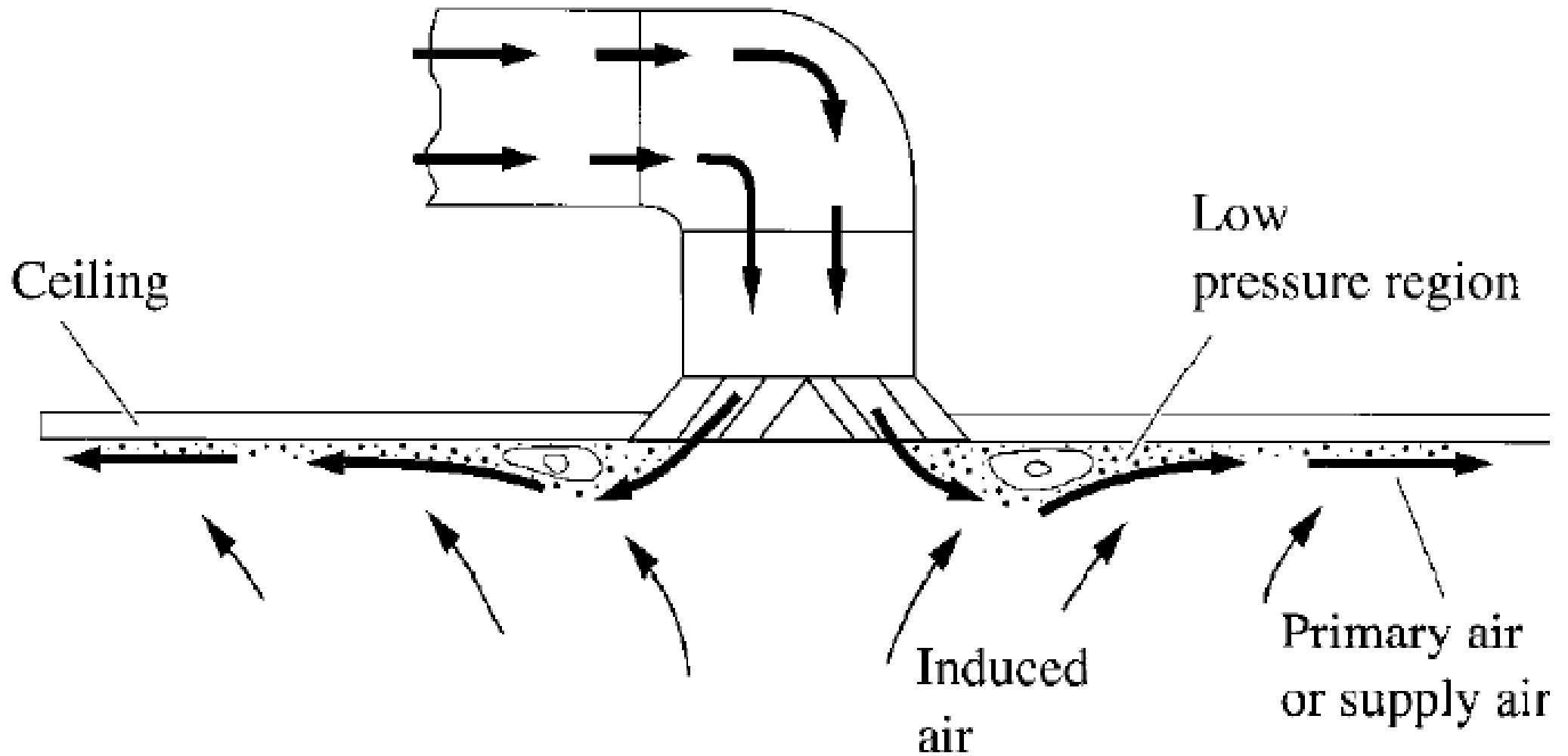

Surface effect (or Coanda effect)

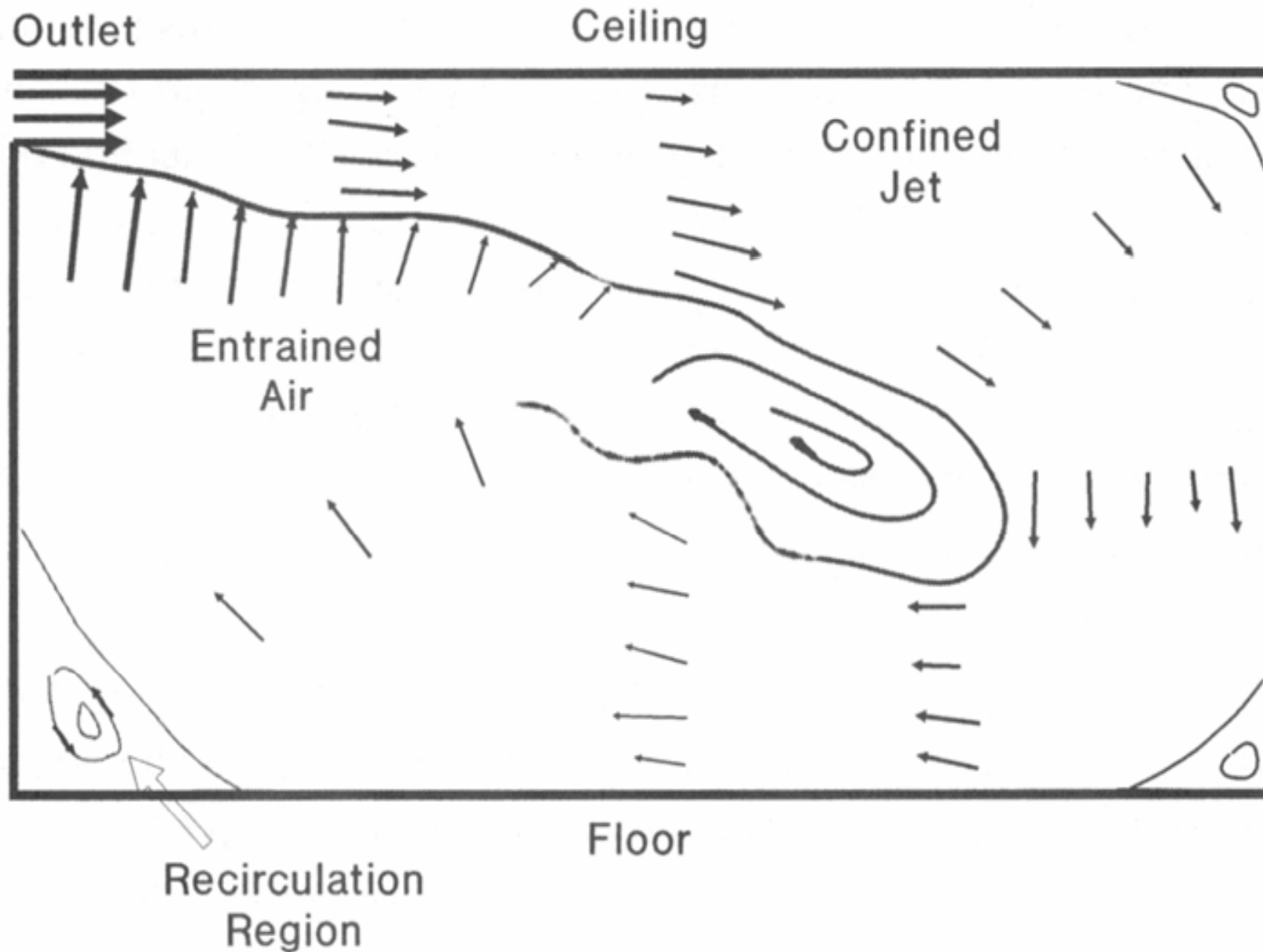

Figure 5.11 Because a real room has a limited volume, a jet's growth and shape are affected. A "confined jet" is the result.

(Source: Rock, B. A. and Zhu, D., 2002. *Designer's Guide to Ceiling-based Air Diffusion*.)



Air Jets

- Free nonisothermal jets
 - Supply air at different temp. from ambient air
 - Buoyancy of air causes trajectory of the air jet

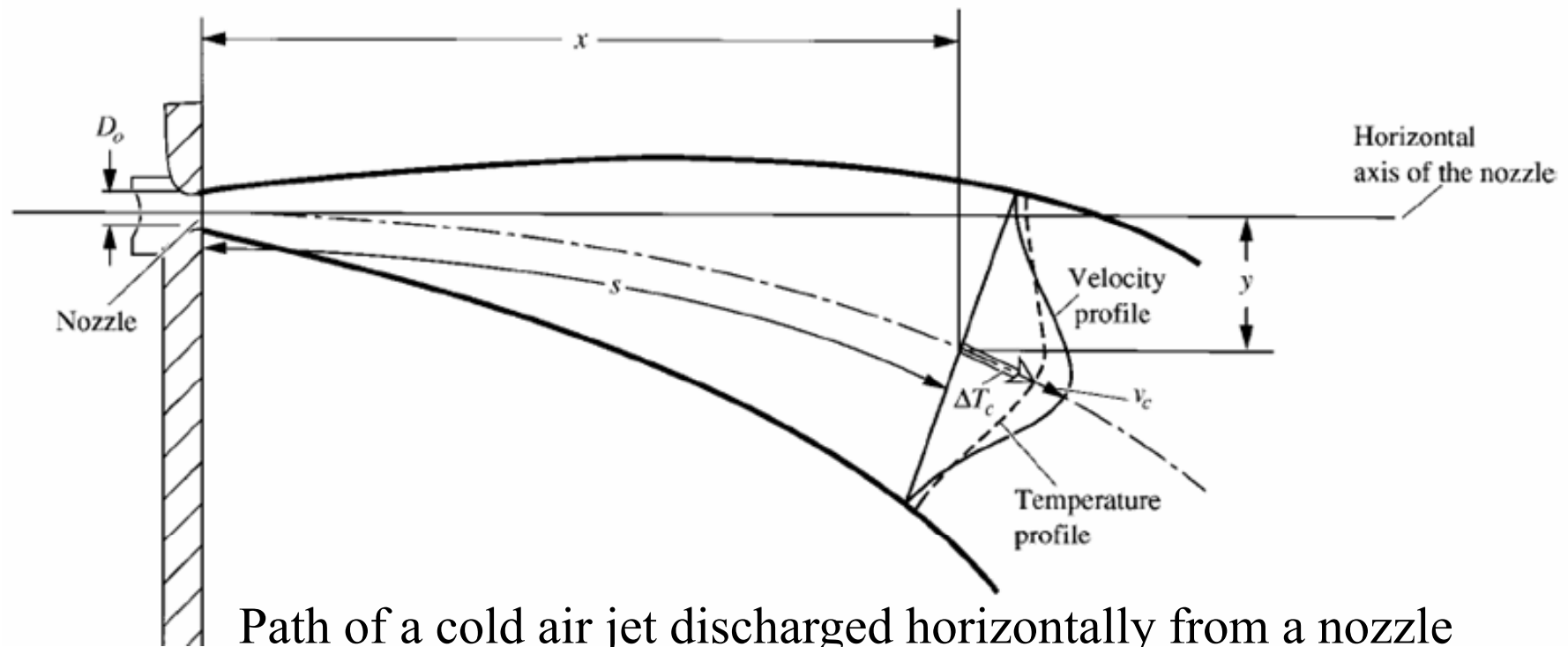

Path of a cold air jet discharged horizontally from a nozzle

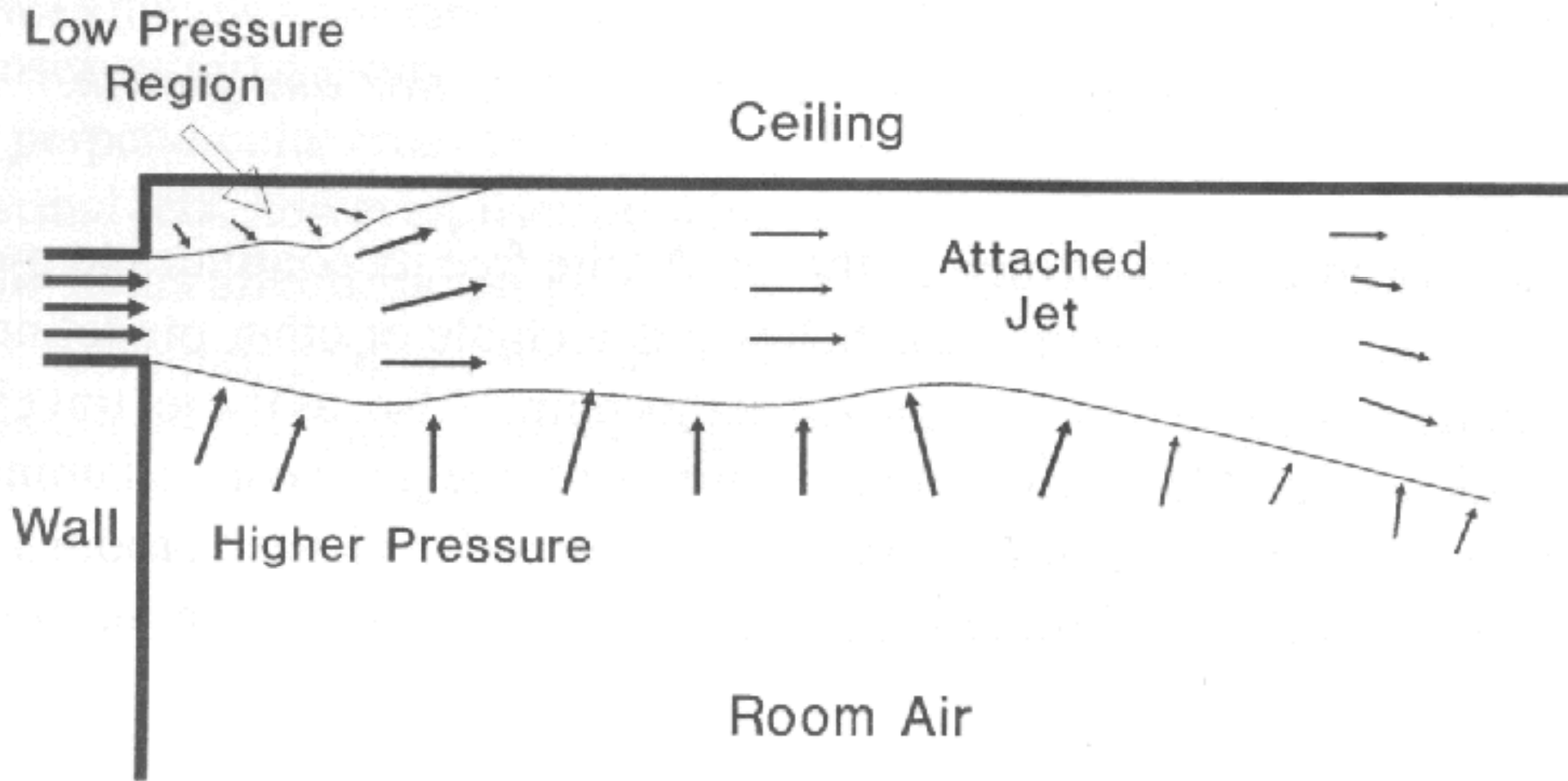

Figure 5.9 *A jet attaches to a surface like a ceiling because entrainment is limited on that side.*

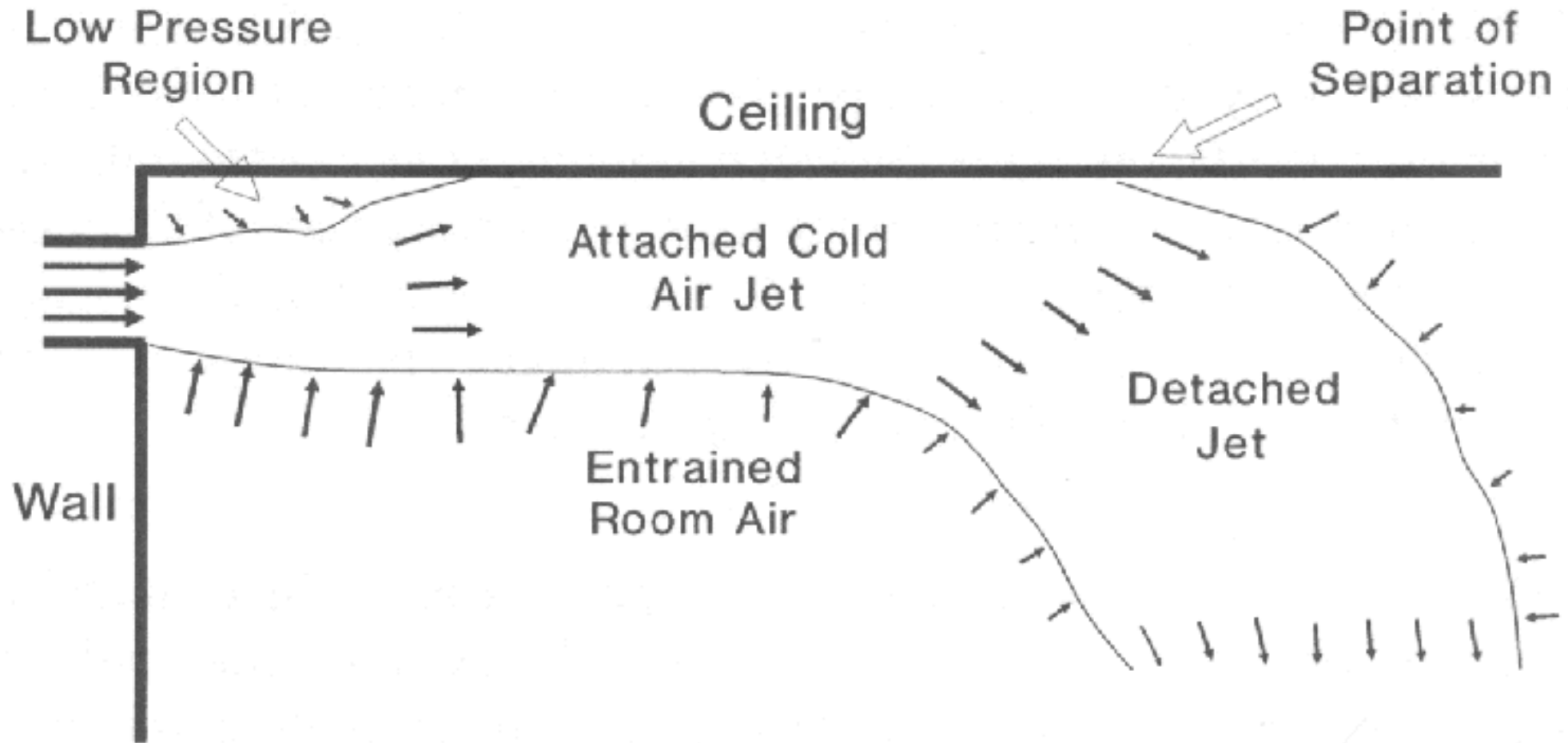
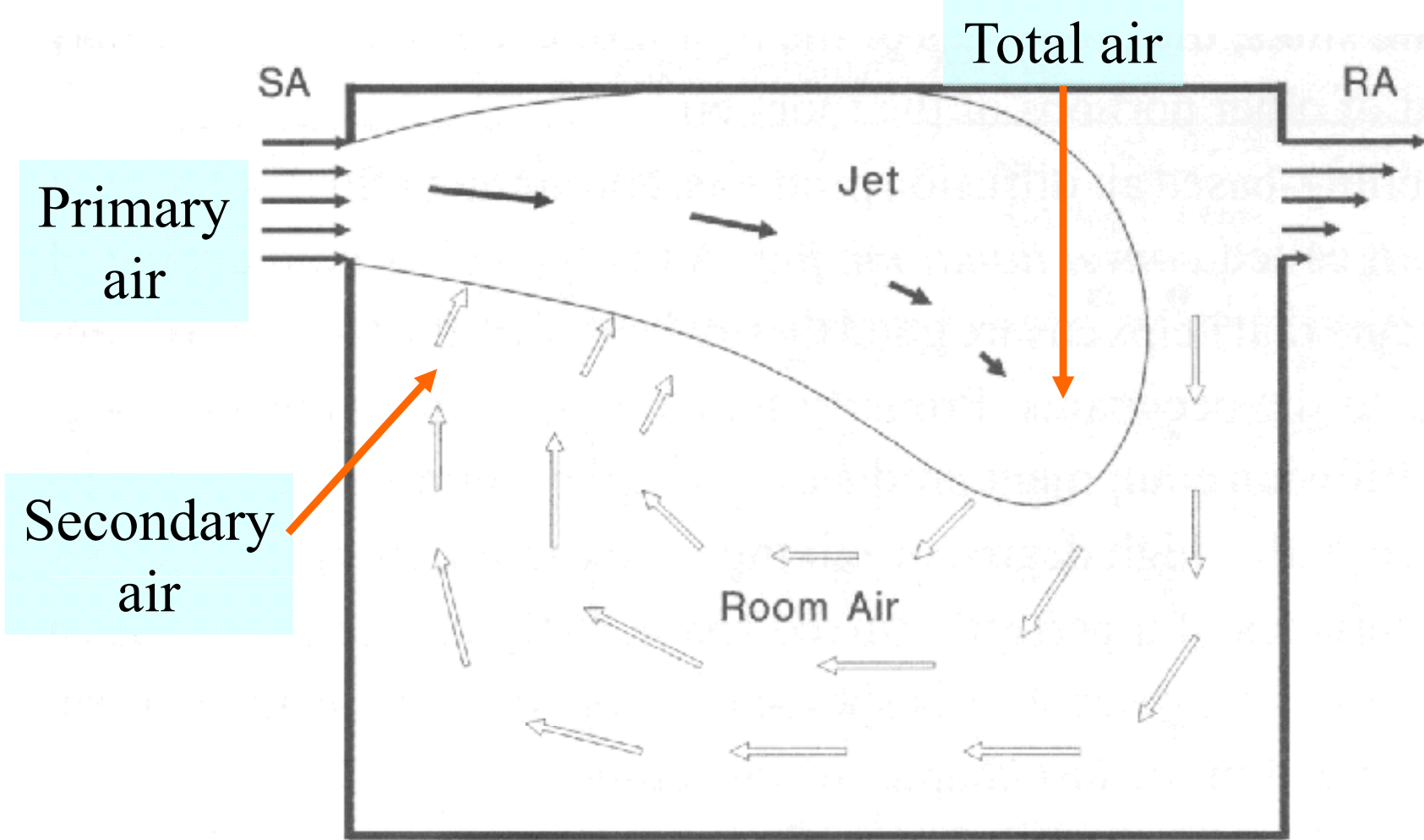

Figure 5.10 *If a cool air ceiling jet slows to the point that negative buoyancy overcomes the force causing attachment, the jet detaches from the ceiling.*



"Entrainment" or "Conventional-Mixing" Flow

Figure 6.2 *Real airflows in rooms are most often "entrainment flow" or "conventional mixing" where confined jets and surfaces affect the resulting pattern.*

(Source: Rock, B. A. and Zhu, D., 2002. *Designer's Guide to Ceiling-based Air Diffusion*.)

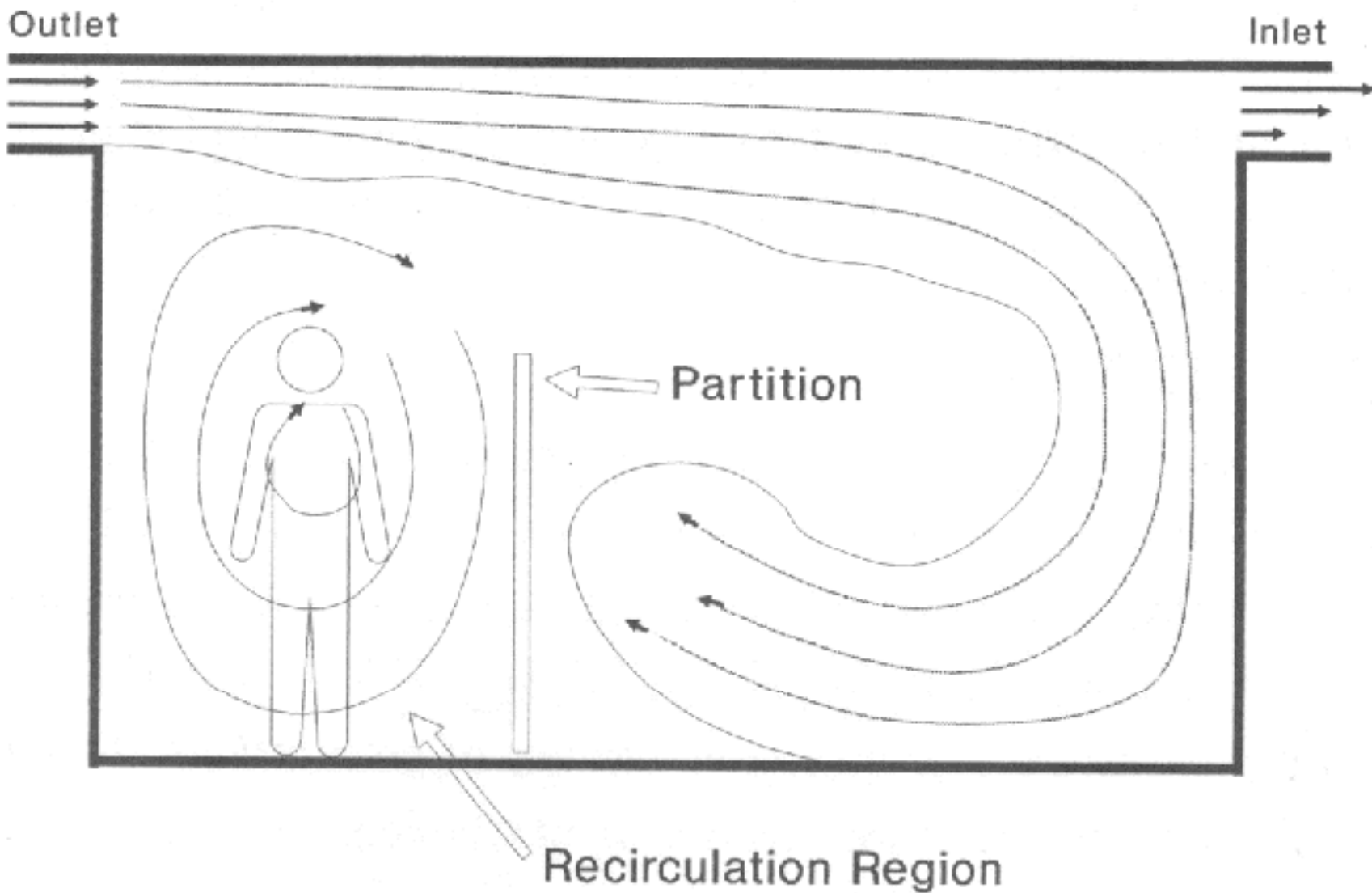

Figure 6.3 *Recirculation regions often form due to limiting objects and surfaces within spaces, or the characteristics of the jet and the room.*

(Source: Rock, B. A. and Zhu, D., 2002. *Designer's Guide to Ceiling-based Air Diffusion*.)

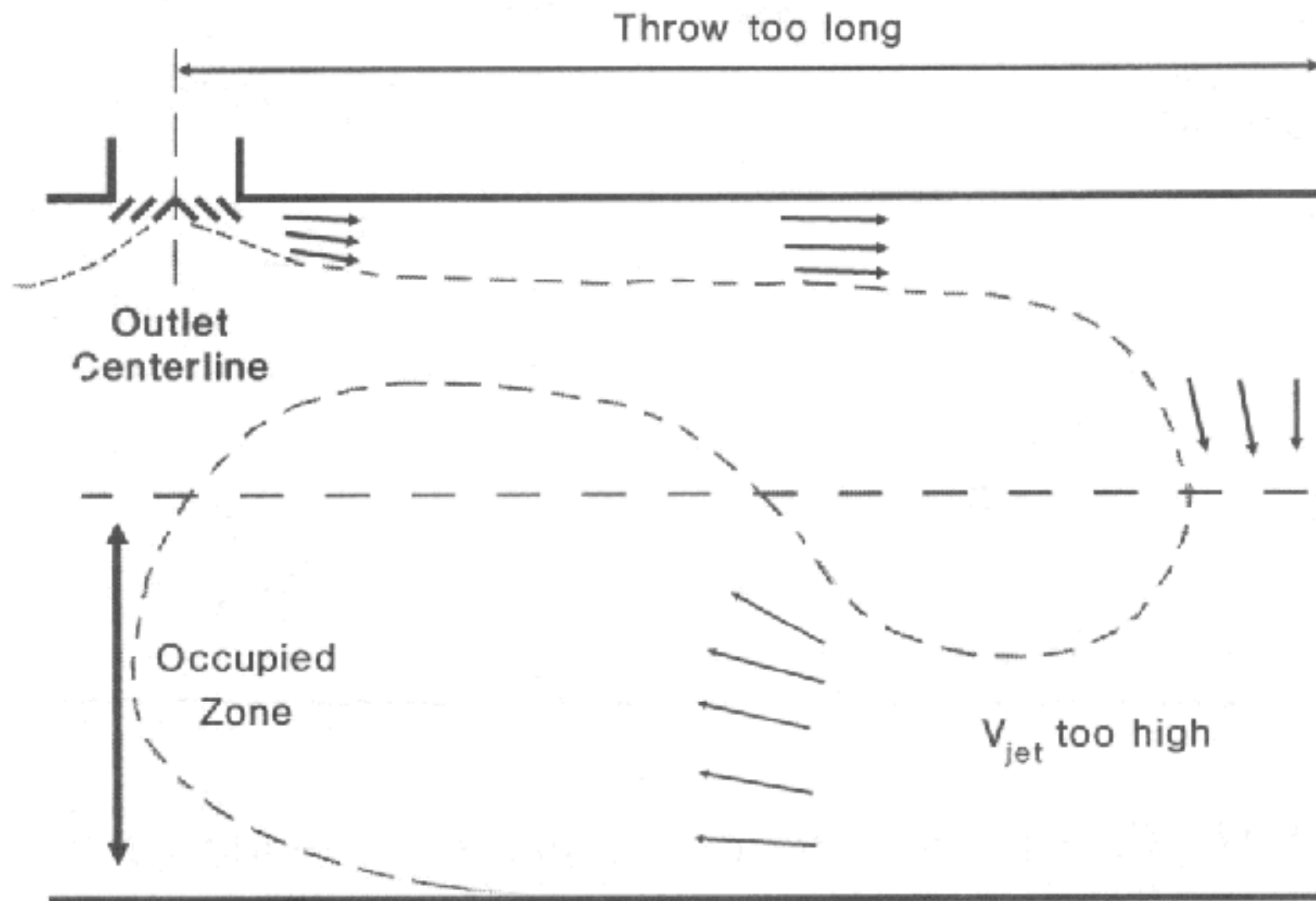

Figure 6.9 When a jet's throw is too long, the velocity and the temperature of the air entering the occupied zone may be objectionable.

(Source: Rock, B. A. and Zhu, D., 2002. *Designer's Guide to Ceiling-based Air Diffusion*.)

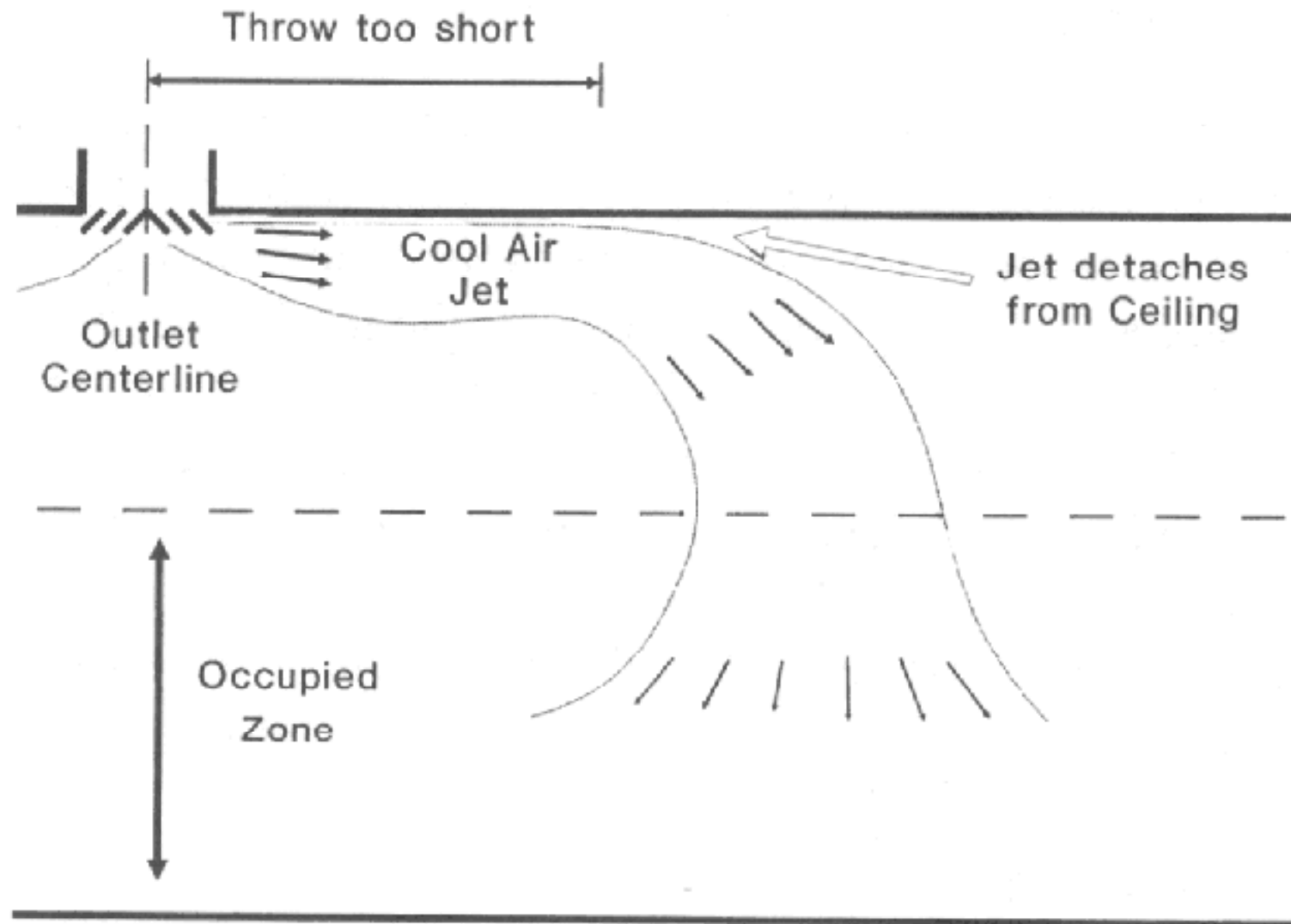

Figure 6.10 “Dumping” is when a jet enters the occupied zone and is objectionable. Detachment is one potential cause of dumping, and can be created by too little airflow and/or an oversized outlet.

(Source: Rock, B. A. and Zhu, D., 2002. *Designer’s Guide to Ceiling-based Air Diffusion*.)

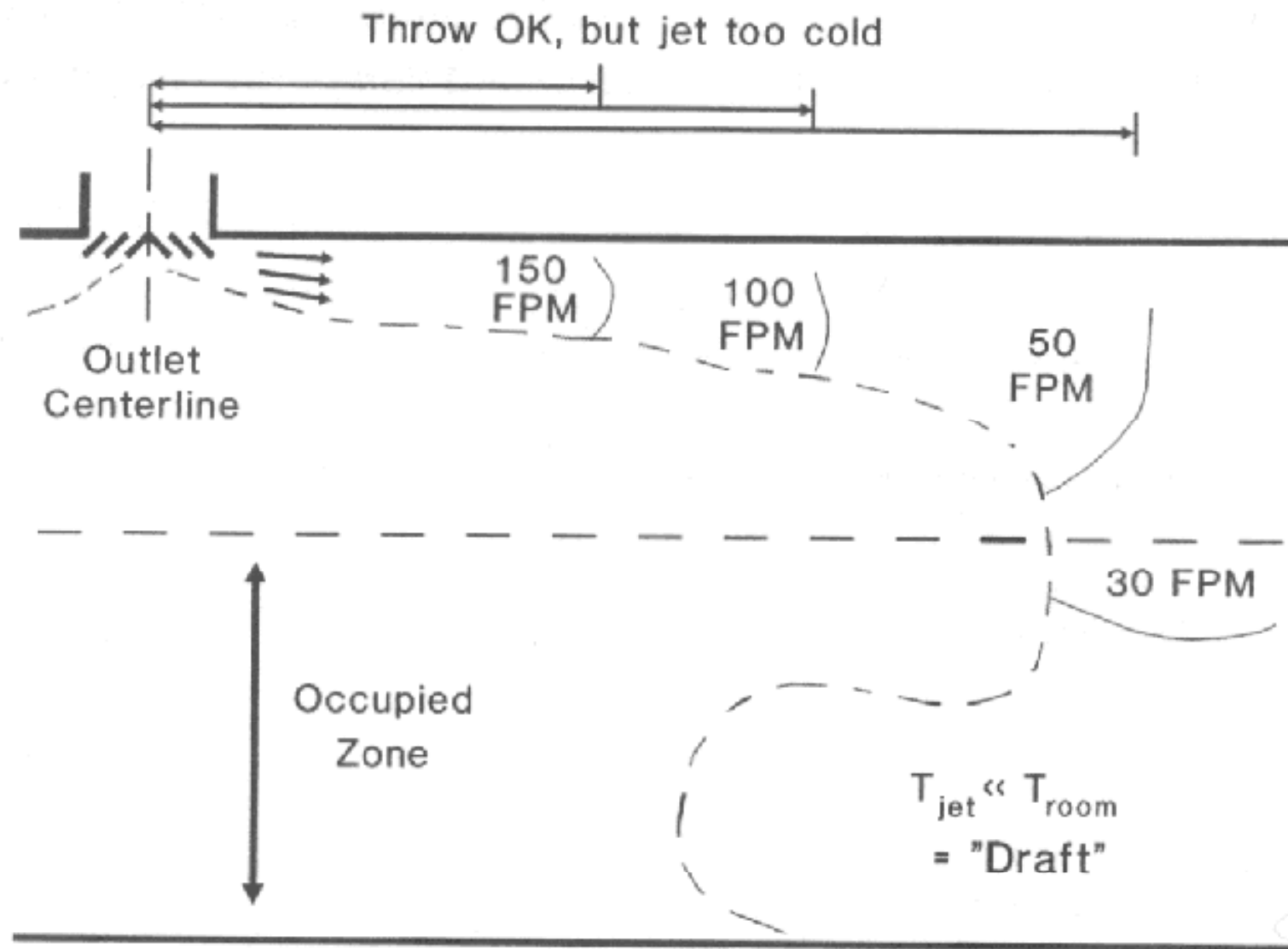

Figure 6.11 Even if velocities are acceptable, too large a temperature difference between the jet and the room air can also cause "draft" complaints.

(Source: Rock, B. A. and Zhu, D., 2002. *Designer's Guide to Ceiling-based Air Diffusion*.)



Outlets and Inlets

- Supply outlets
 - Grilles and registers
 - Ceiling diffusers
 - Slot diffusers
 - Nozzles
- Return & exhaust inlets
- Light troffer diffuser & troffer-diffuser slot
- Design issues: architectural setup, airflow pattern needed, indoor requirements, load conditions

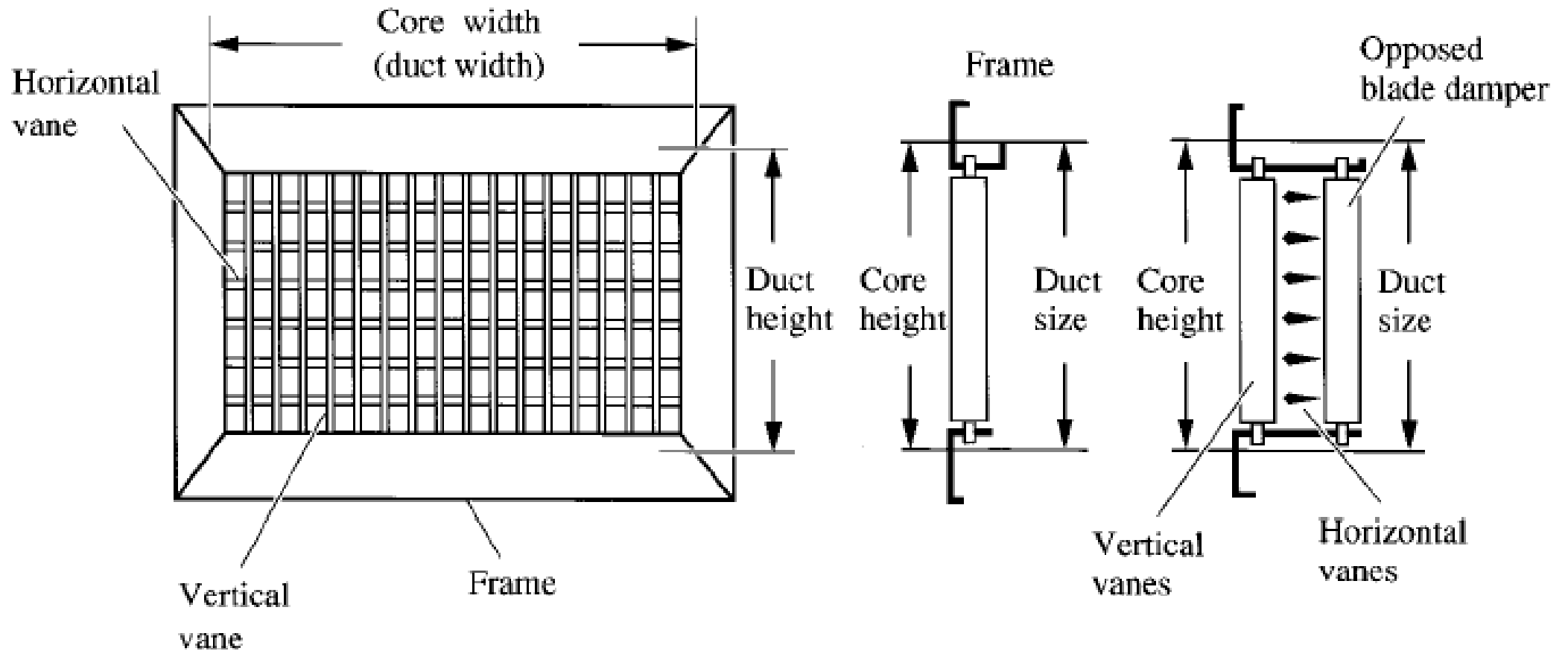

Supply grille and register

(Source: Wang, S. K., 2001. Handbook of Air Conditioning and Refrigeration)

0° DEFLECTION

45° DEFLECTION

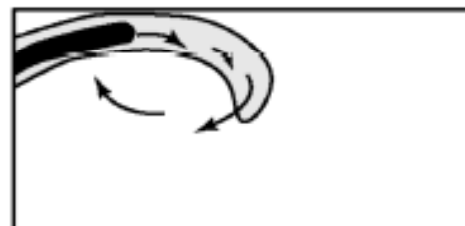
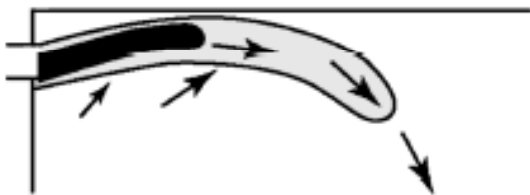
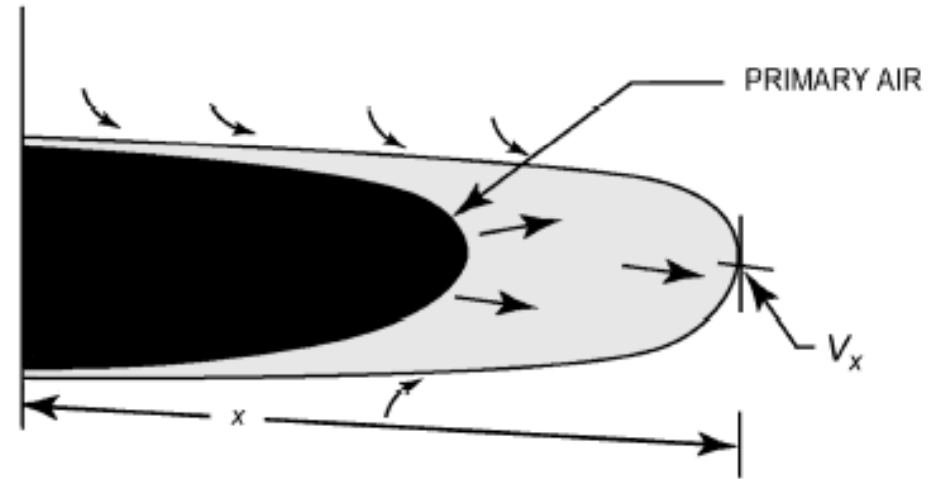
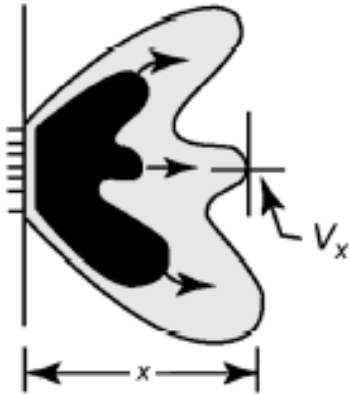
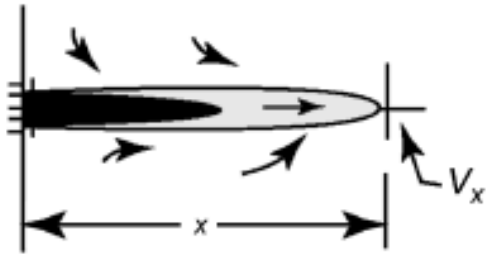

HIGH FLOW RATE
LONG THROW

LOW FLOW RATE
SHORT THROW

Note: Throw values based on 1.2 m long, isothermal active section.
Correction multipliers for other lengths are as follows:

Active length, m	0.6	1.2	2.4	3
Throw correction	0.72	1	1.5	1.7

A. HIGH SIDEWALL GRILLES

B. HIGH SIDEWALL LINEAR

Airflow patterns of high sidewall supply grilles

(Source: ASHRAE Handbook Fundamentals 2001)



Outlets and Inlets

- Performance data of grilles and registers
 - Core size or core area
 - Volume flow rate
 - Air velocity
 - Total pressure loss
 - Throw at various terminal velocities
 - Noise criteria curve

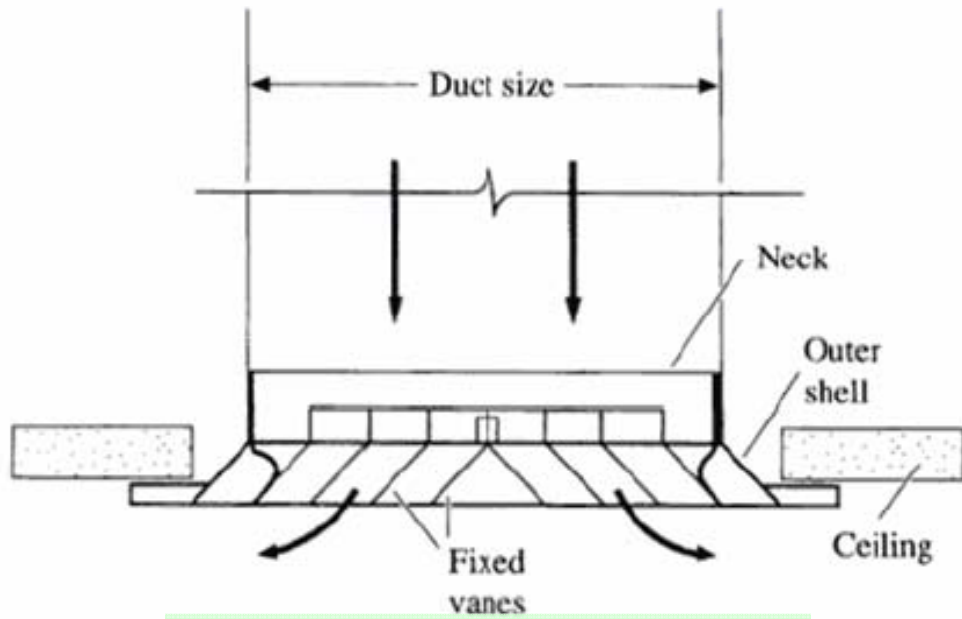

Square & rectangular

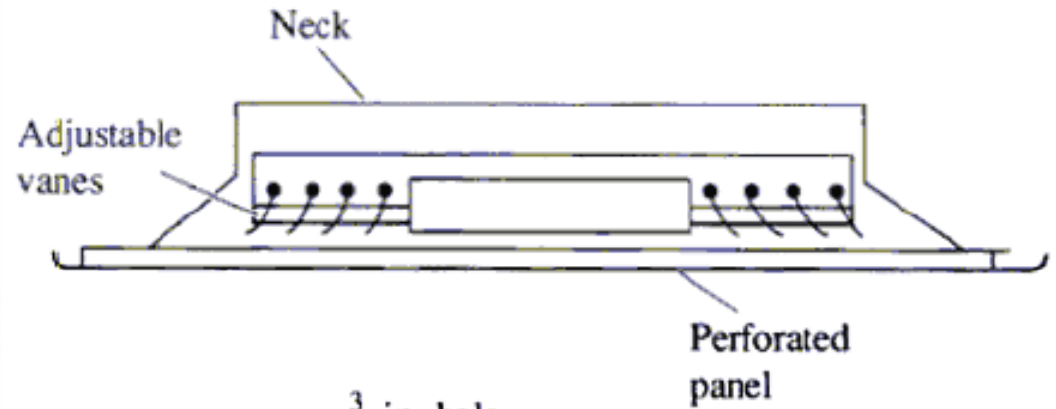

$\frac{3}{16}$ in. hole

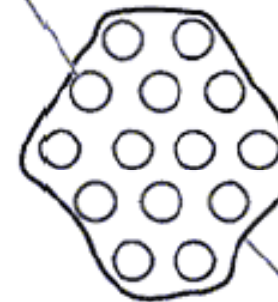

Perforated panel

Perforated ceiling diffuser

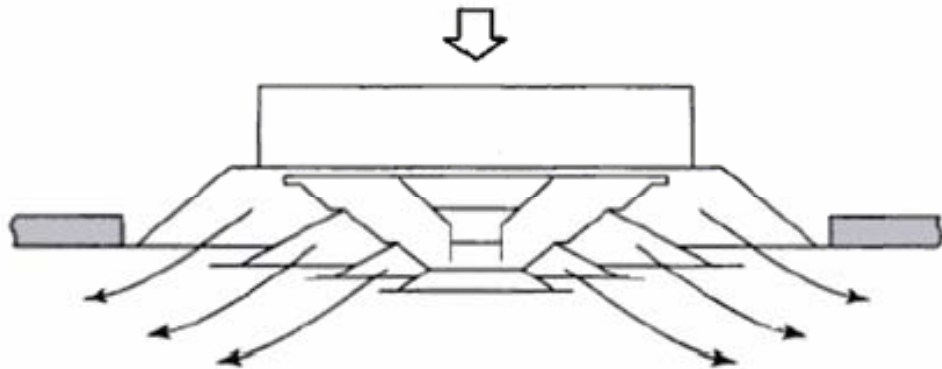

Removable inner-core

Ceiling diffusers

(Source: Wang, S. K., 2001. Handbook of Air Conditioning and Refrigeration)

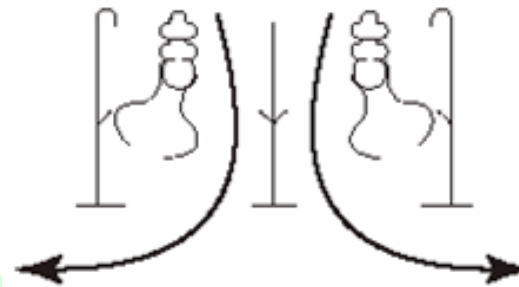
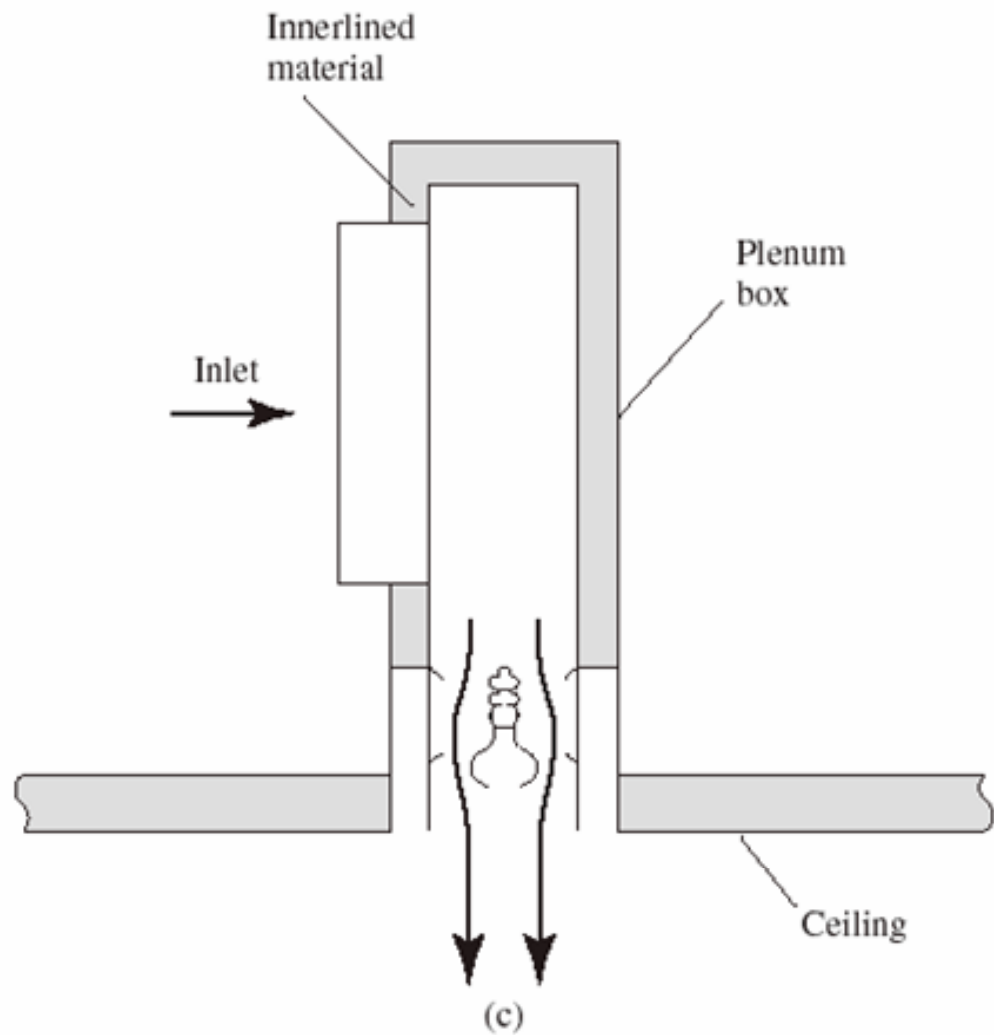
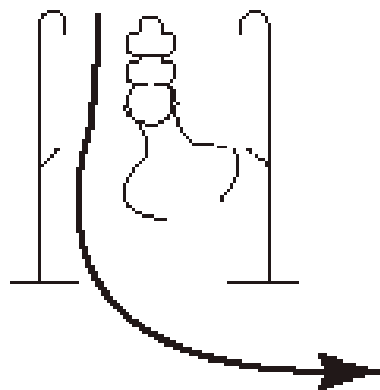
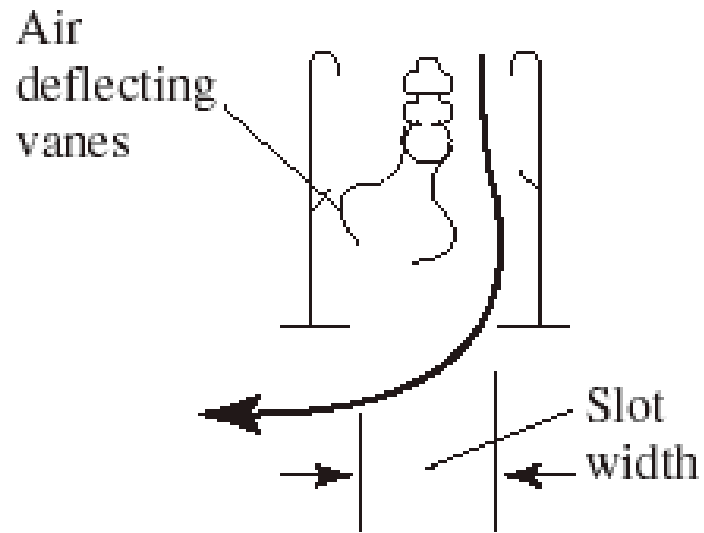

Slot diffusers

(Source: Wang, S. K., 2001. Handbook of Air Conditioning and Refrigeration)

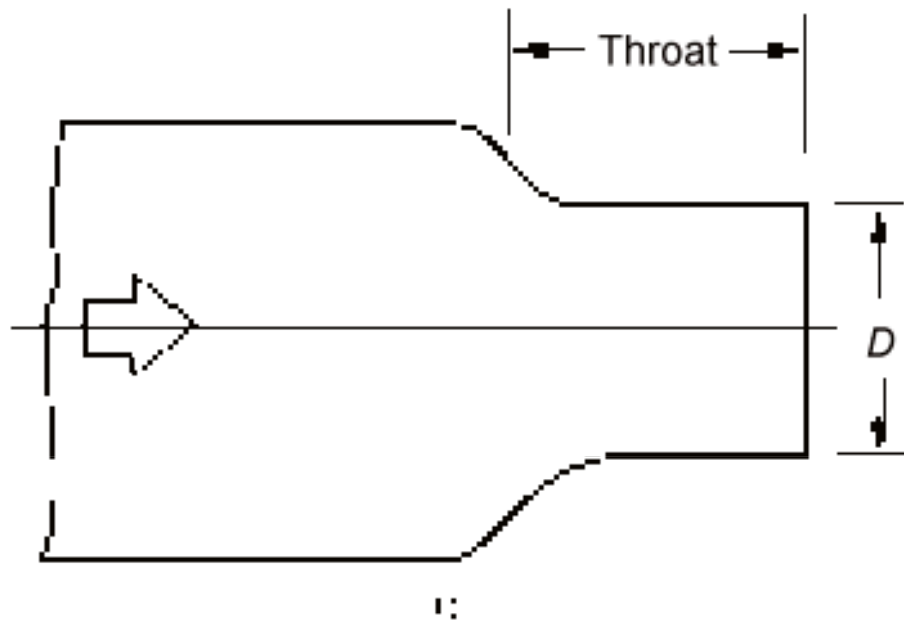

Round nozzle

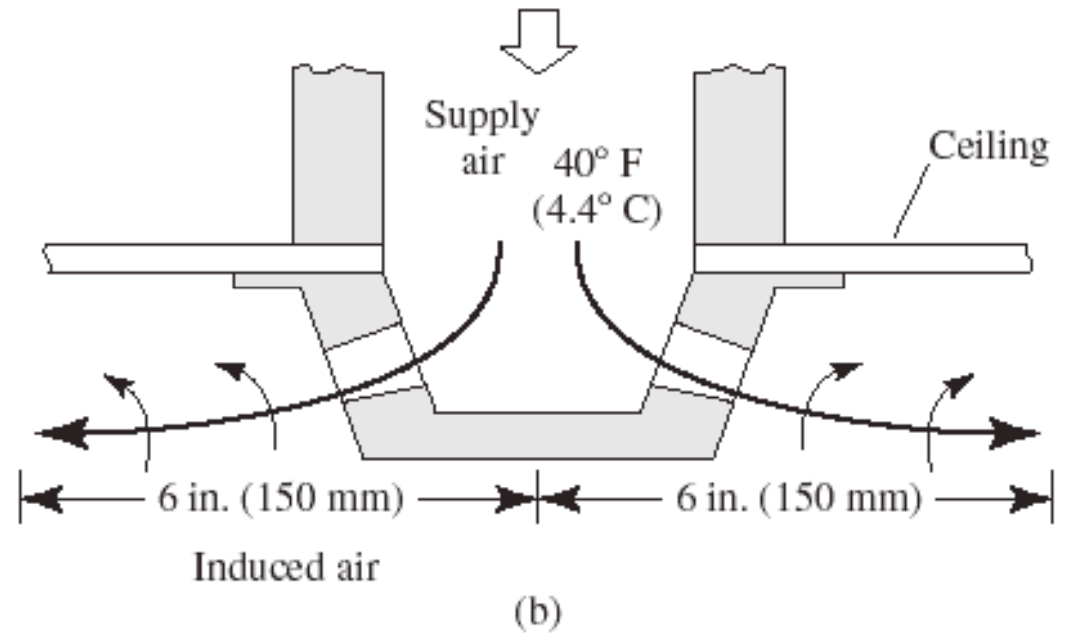

Nozzle diffuser

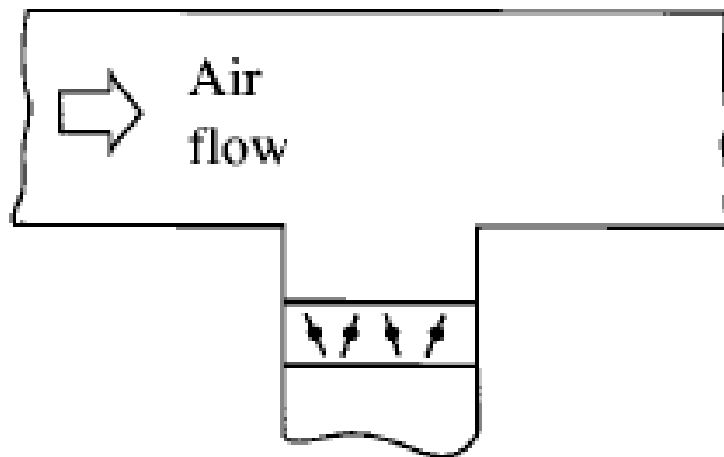

Outlet collar

(a)

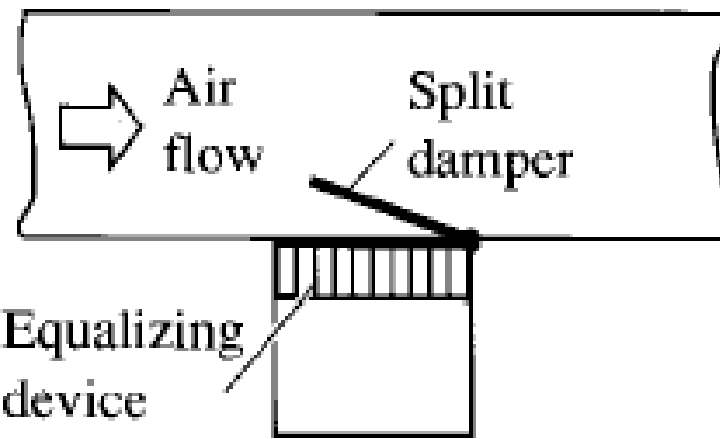

Outlet collar

(b)

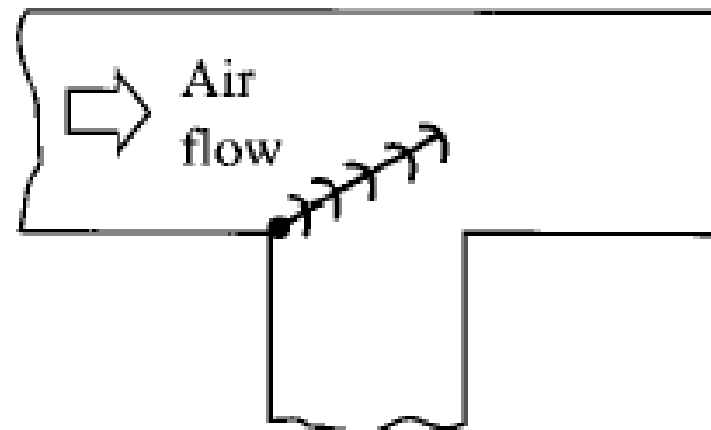

(c)

Accessories for supply outlets

(Source: Wang, S. K., 2001. Handbook of Air Conditioning and Refrigeration)

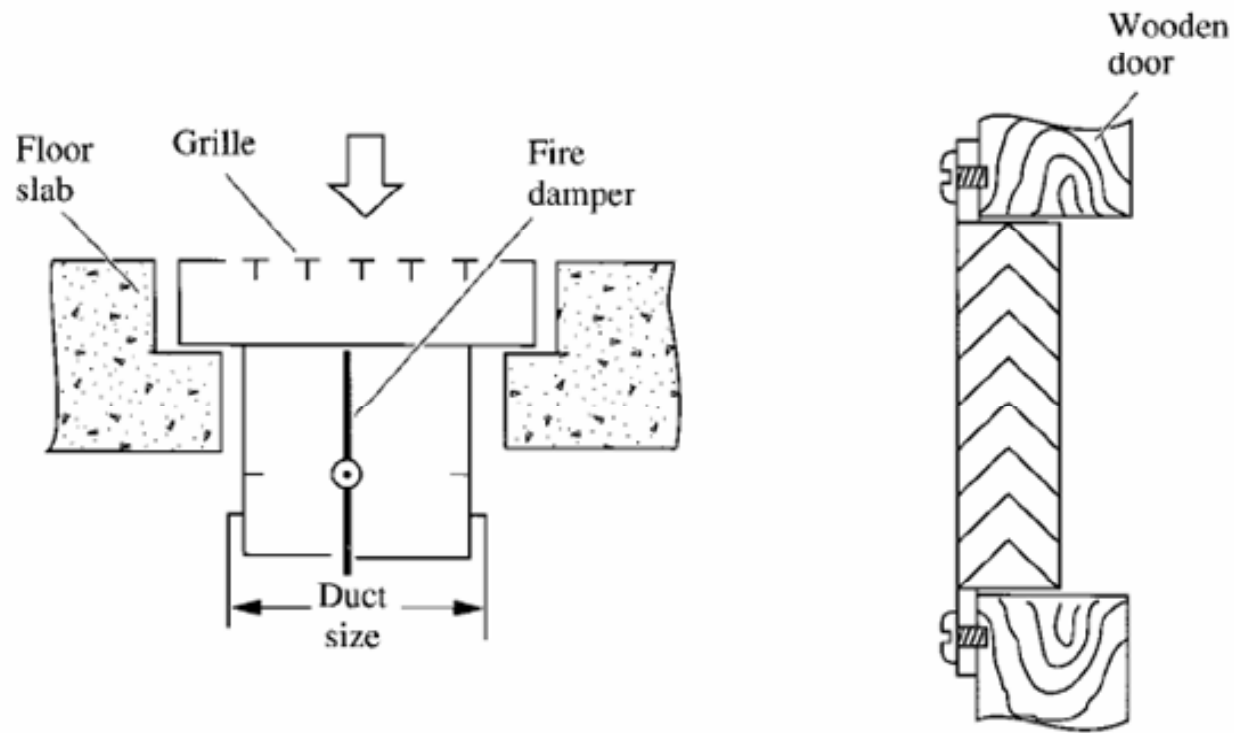
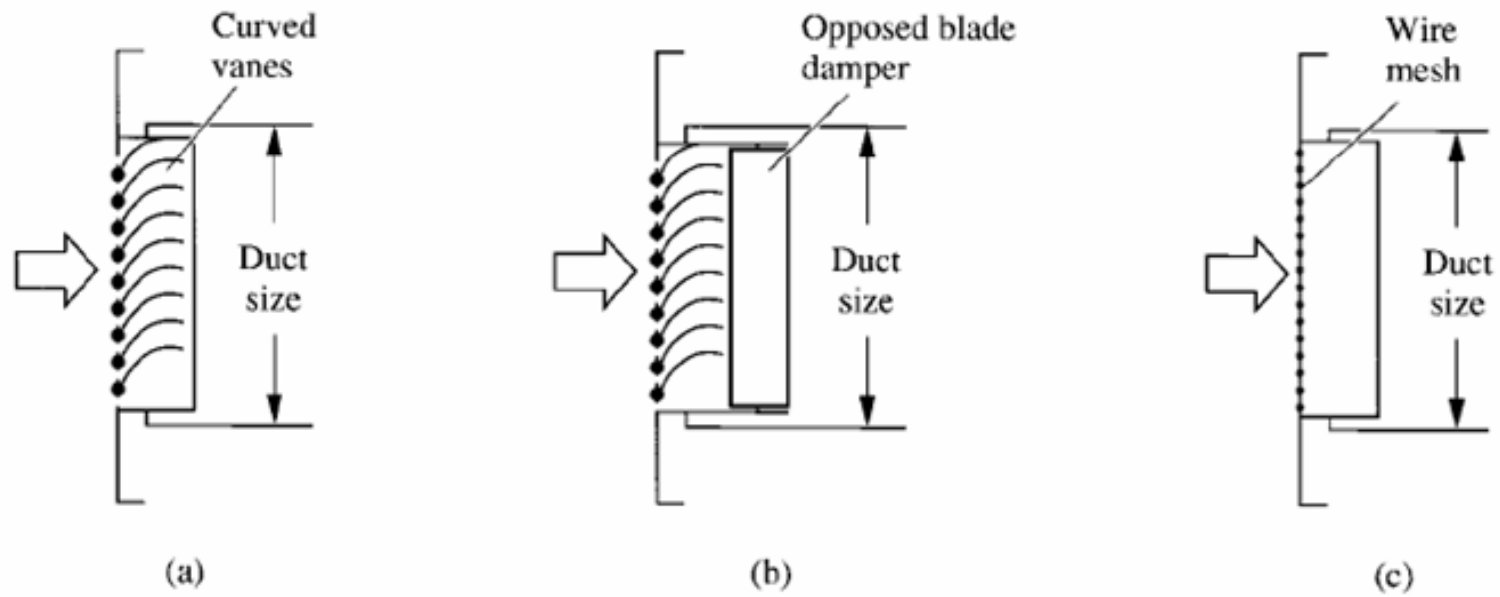

Return grilles and registers

(Source: Wang, S. K., 2001. Handbook of Air Conditioning and Refrigeration)

Inner lining

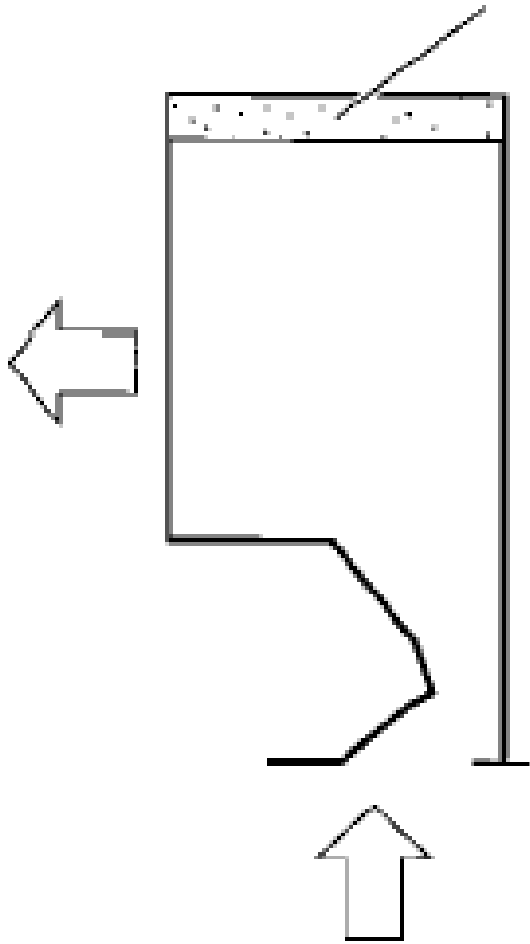

Single-slot

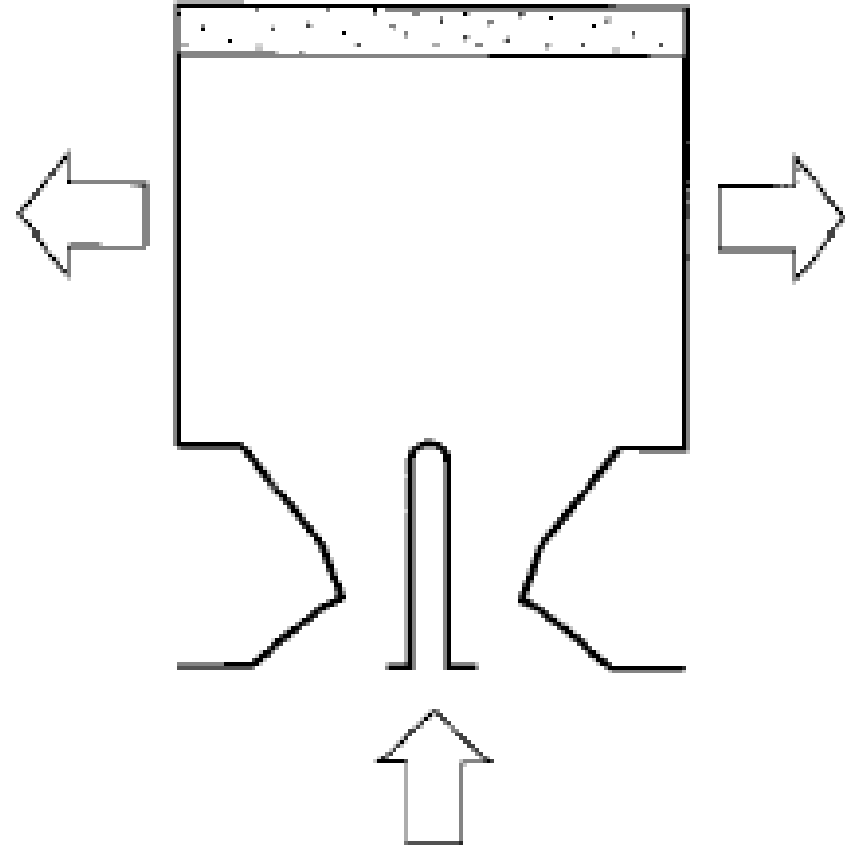

Double-slot

Return slots

(Source: Wang, S. K., 2001. Handbook of Air Conditioning and Refrigeration)

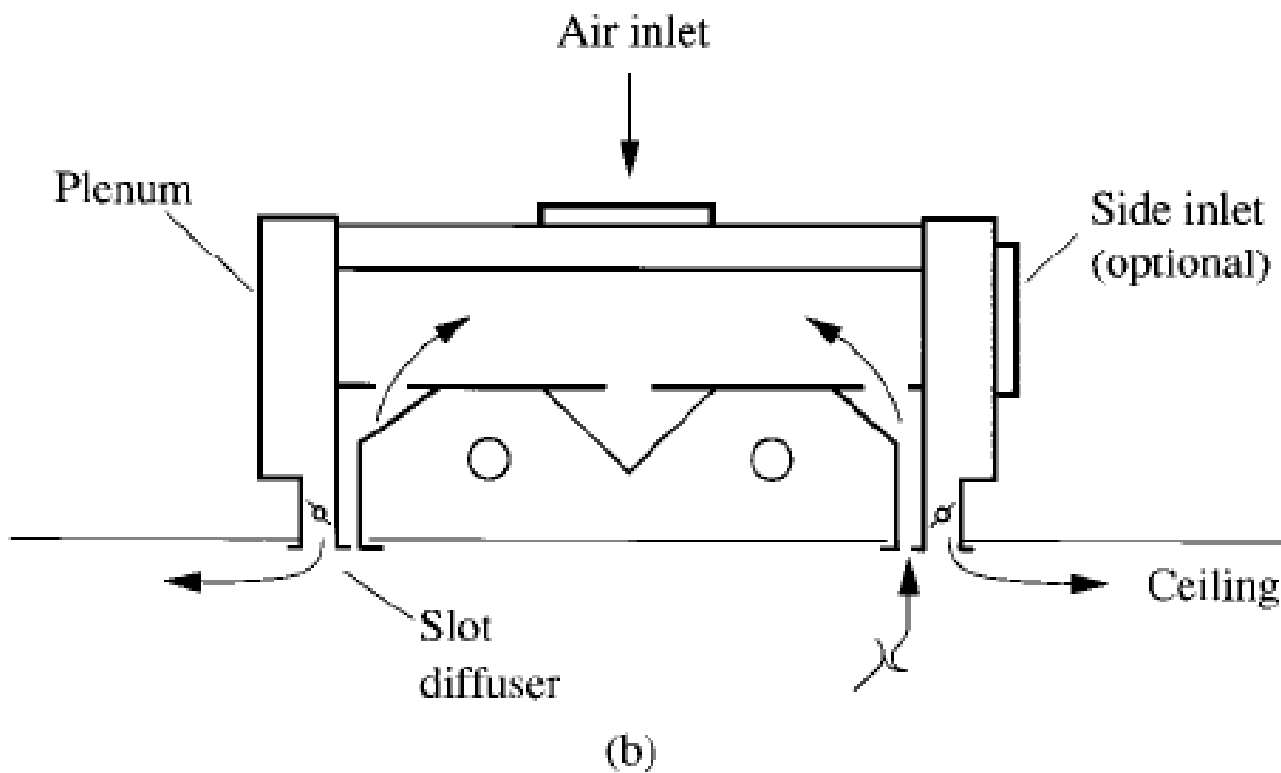
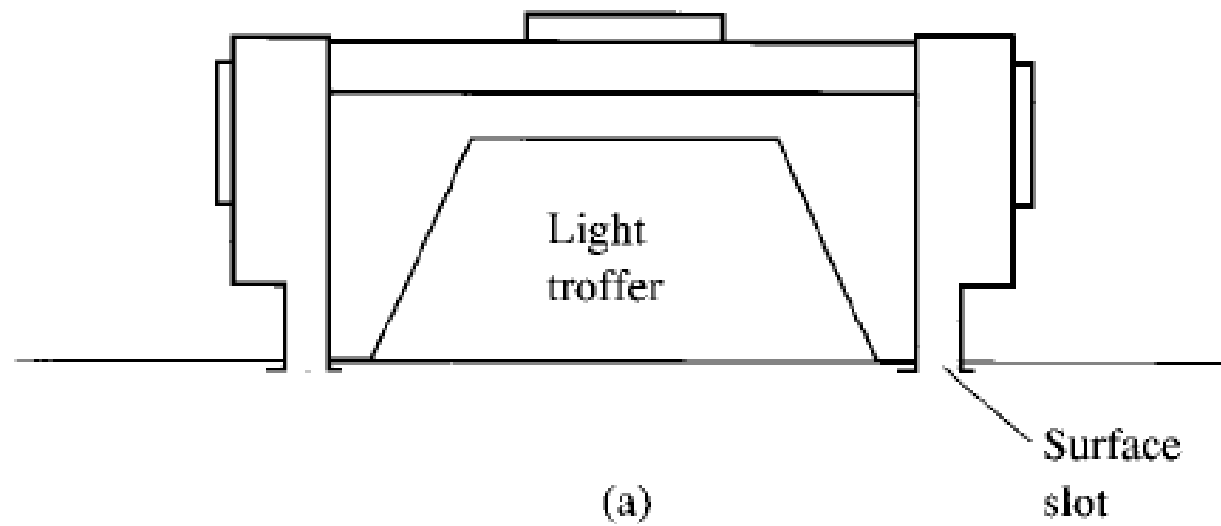

Light troffer, slot diffuser and return slot combination

(Source: Wang, S. K., 2001. *Handbook of Air Conditioning and Refrigeration*)

Mixing Flow



- Four typical airflow patterns for space air diffusion:
 - Mixing flow (most common)
 - Displacement flow – fully stratified (thermally), little or no mixing of air
 - Projecting flow
 - Upward flow
- Also, task or personal air-conditioning systems

Mixing Flow

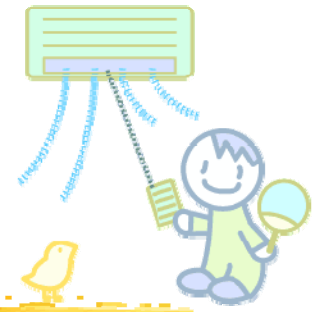

- Principles of mixing flow systems
 - Conditioned air discharged from outlets at high velocity
 - Conditioned air temperature may be above, below or equal to room air, depending on cooling/heating
 - Supply air mixed with room air by entrainment
 - Occupied zone is dominated by induced recirculating flow
 - Creates relatively uniform air velocity, temperature, humidity, and air quality

Mixing Flow



- Characteristics of mixing flow
 - Induction of space air into the air jet
 - Reverse airstream (induced) in occupied zone
 - Minimise the stagnant area in occupied zone
 - Air velocity of stagnant area < 0.1 m/s
 - Types & locations of return & exhaust inlets
 - Does not significantly affect airflow pattern
 - Does affect the thermal effectiveness factor ε_T

Mixing Flow

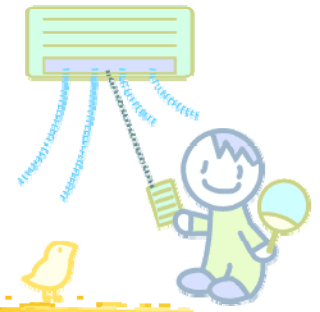

- Outlet classification (from ASHRAE)
 - Group A. mounted in or near ceiling that discharge air horizontally
 - Group B. mounted in or near floor that discharge air vertically in a non-spreading jet
 - Group C. mounted in or near floor that discharge air vertically in a spreading jet
 - Group D. mounted in or near floor that discharge air horizontally
 - Group E. mounted in or near ceiling that project primary air vertically

Group A Outlets

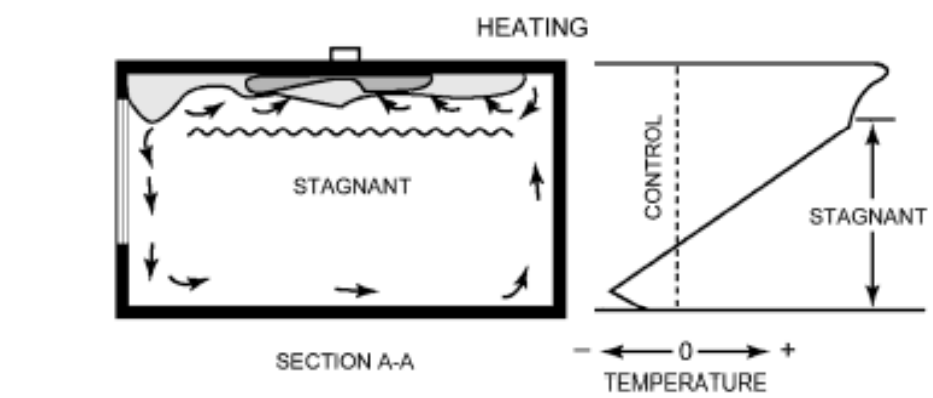
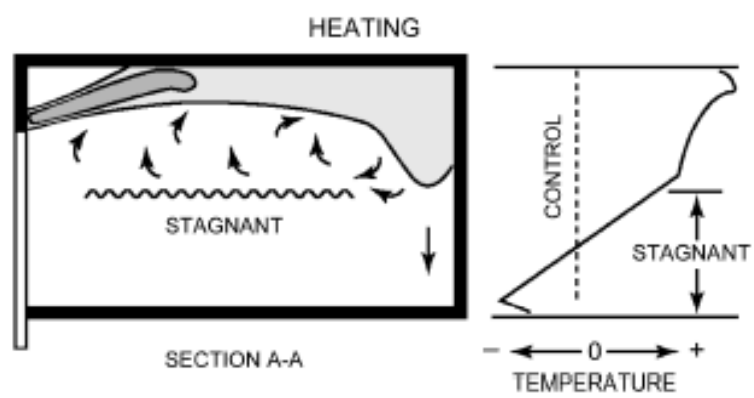
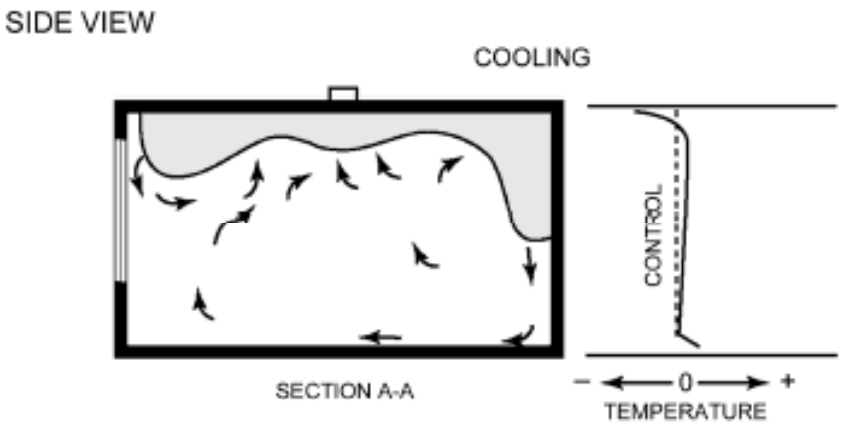
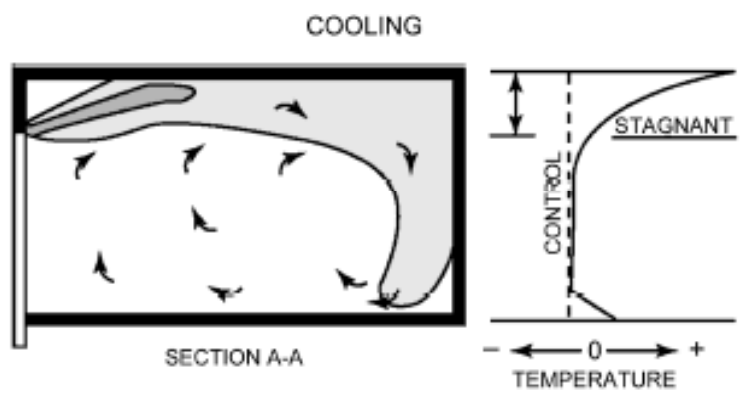
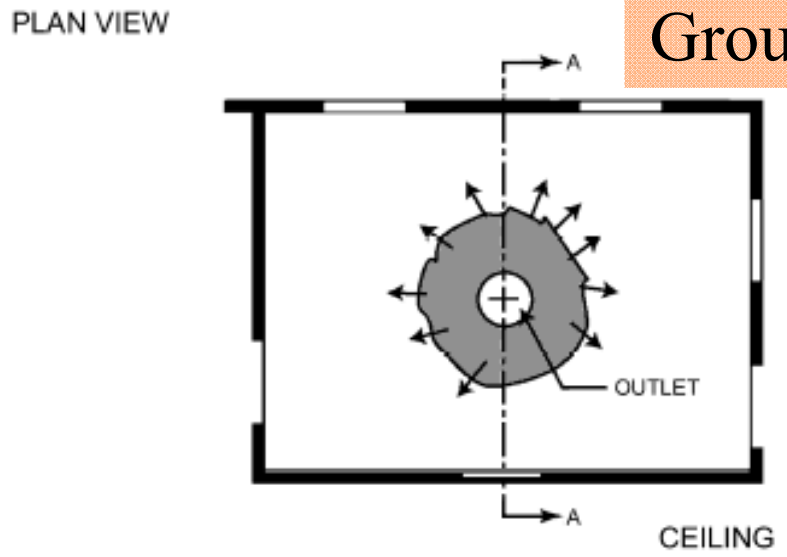
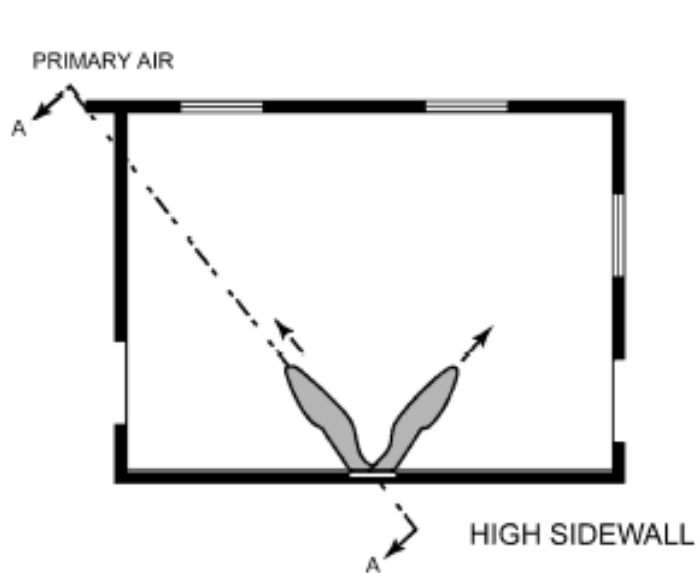

(Source: ASHRAE Handbook Fundamentals 2001)

Group B Outlets

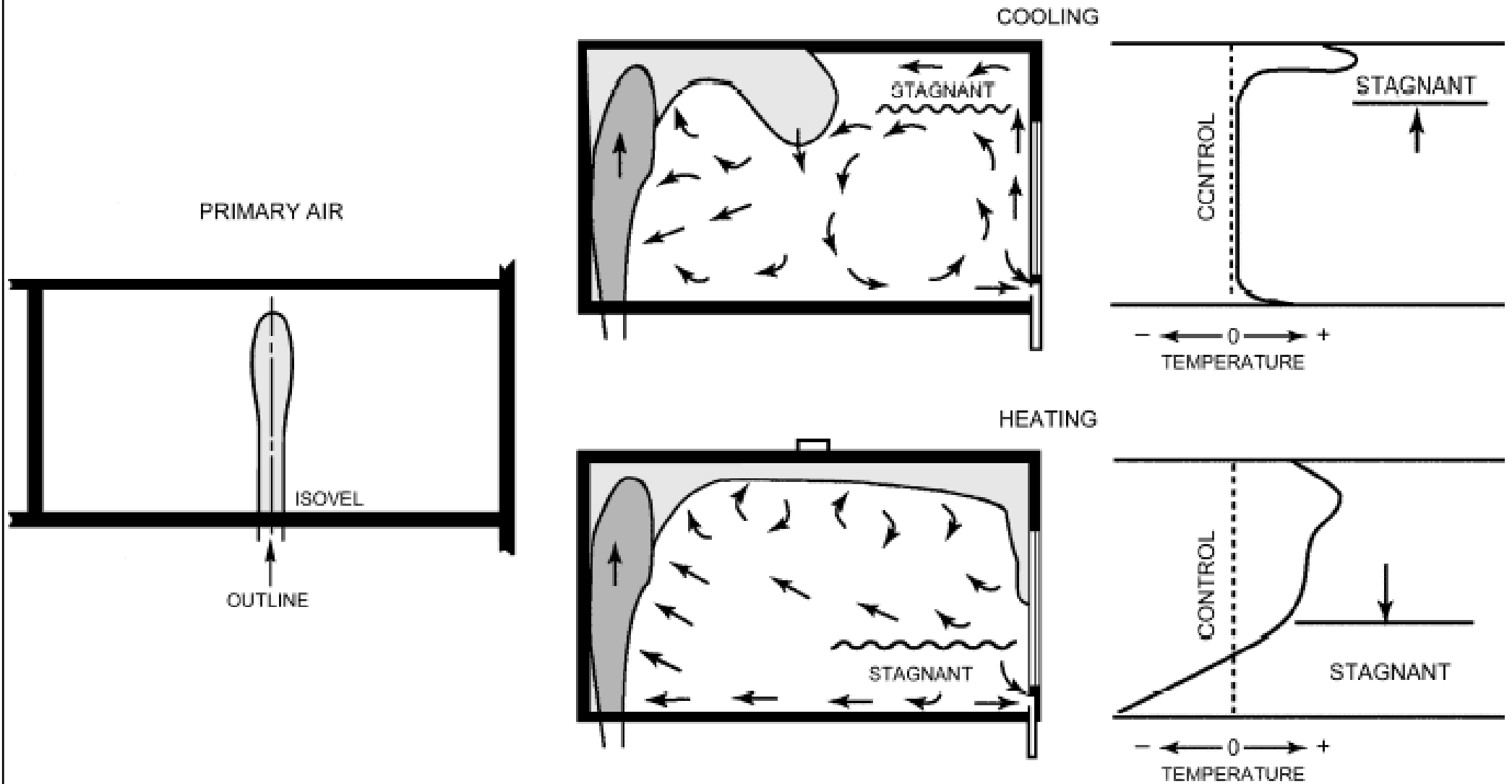

OUTLET IN OR NEAR FLOOR, NONSPREADING VERTICAL JET

(Source: ASHRAE Handbook Fundamentals 2001)

Group C Outlets

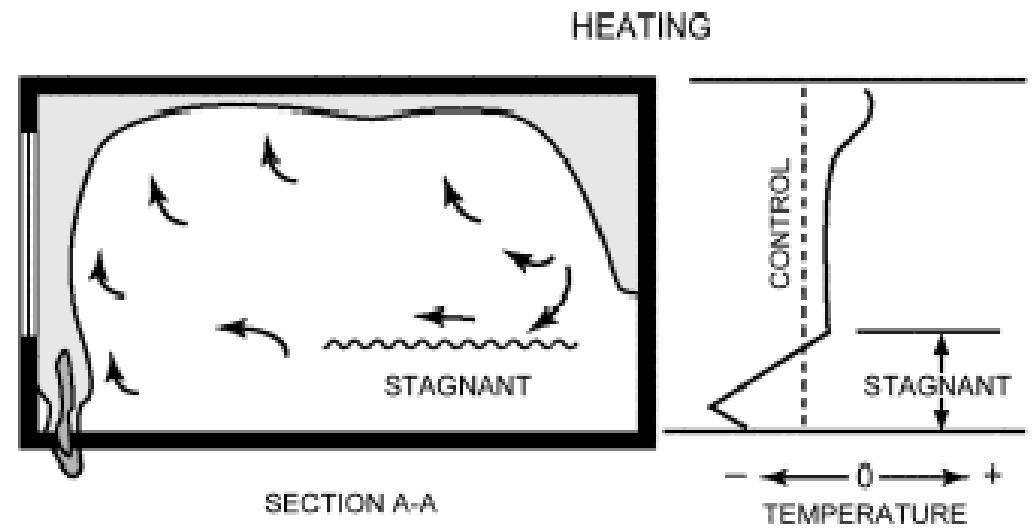
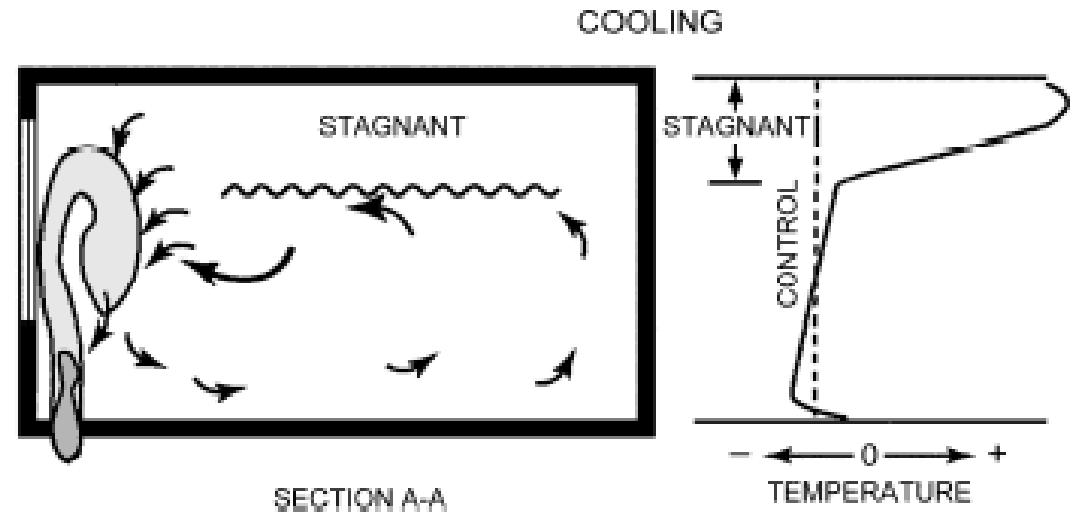
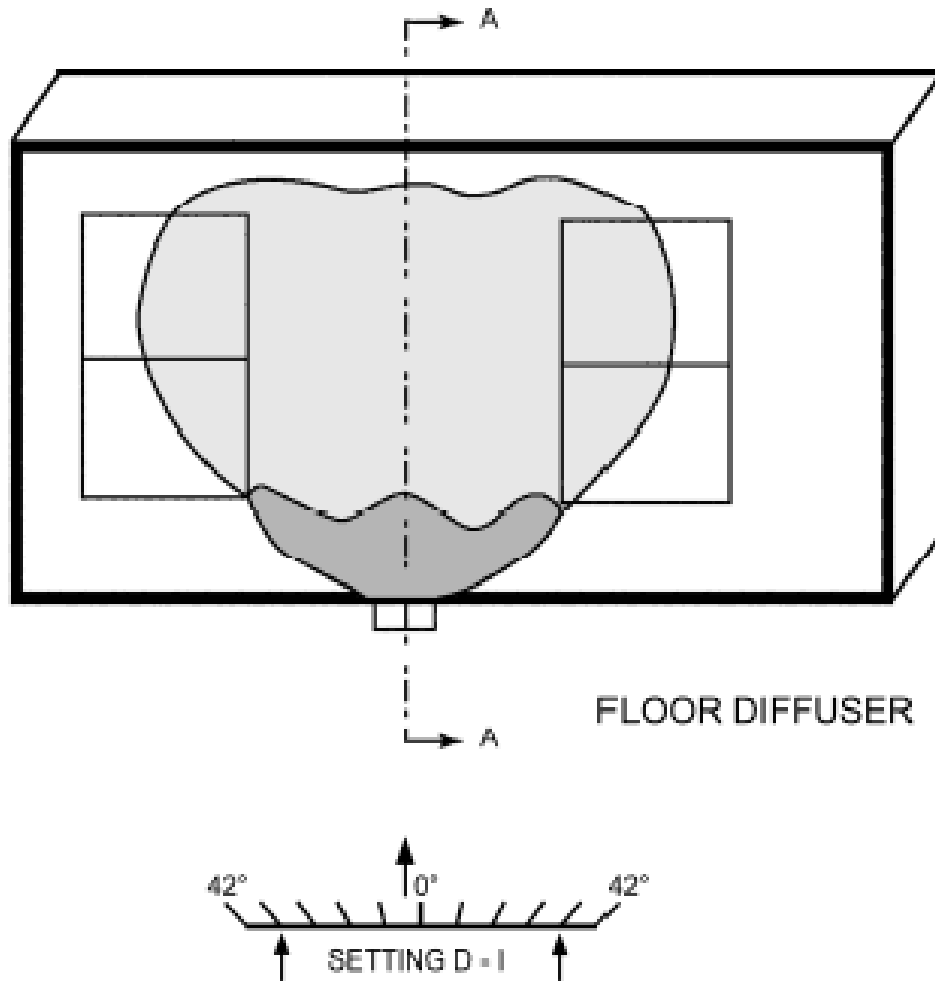

(Source: ASHRAE Handbook Fundamentals 2001)

Group D Outlets

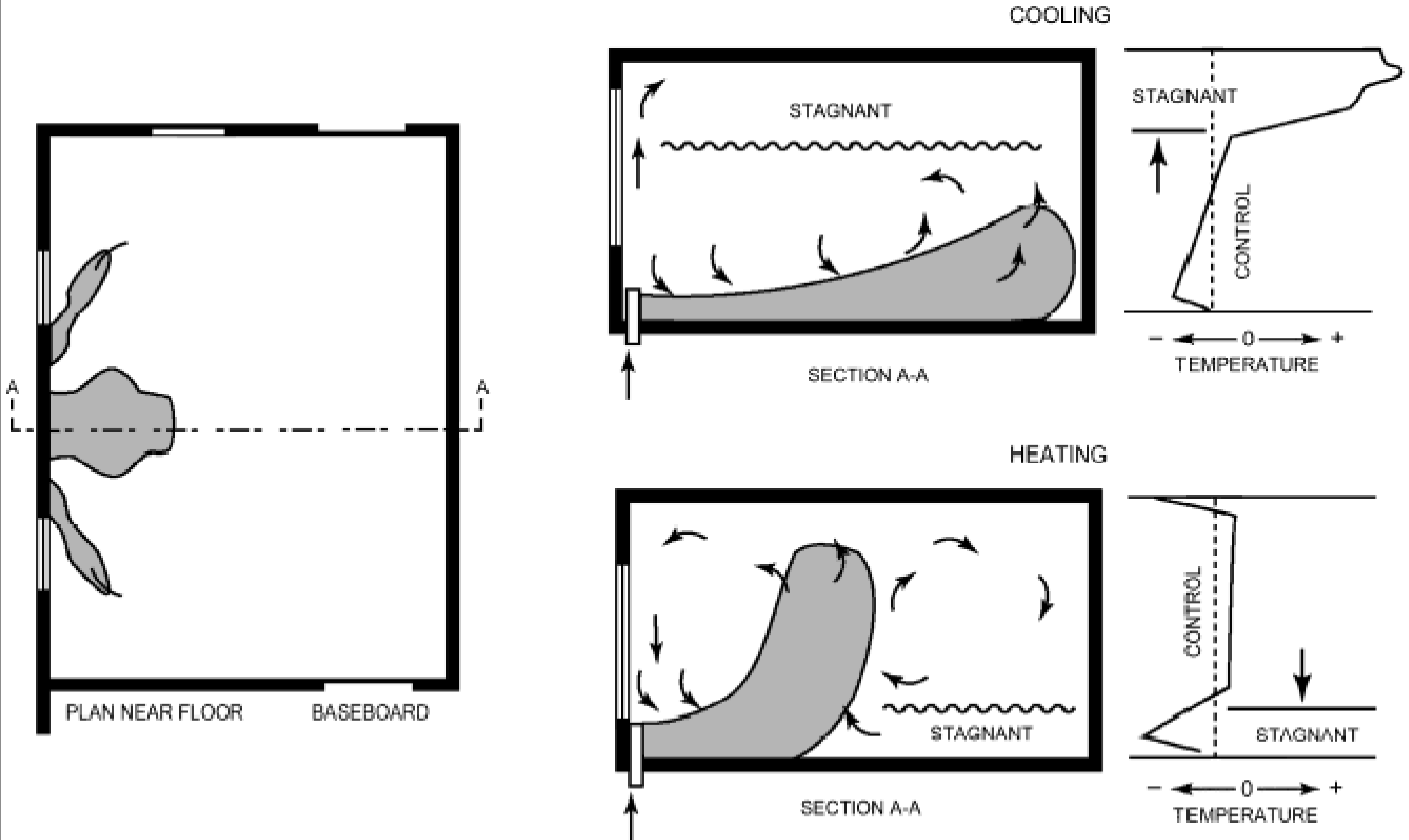

(Source: ASHRAE Handbook Fundamentals 2001)

Group E Outlets

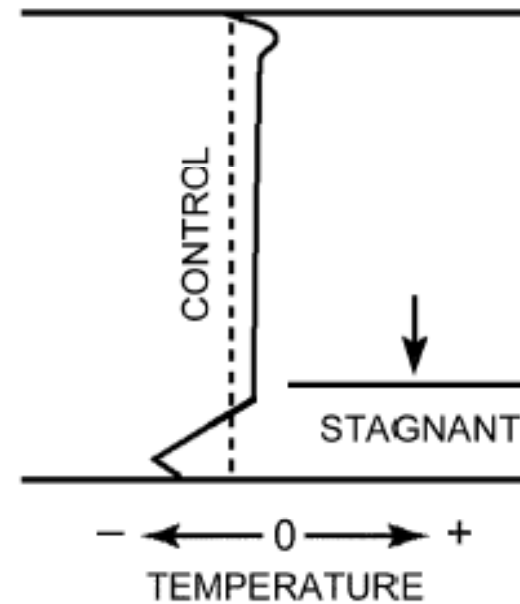
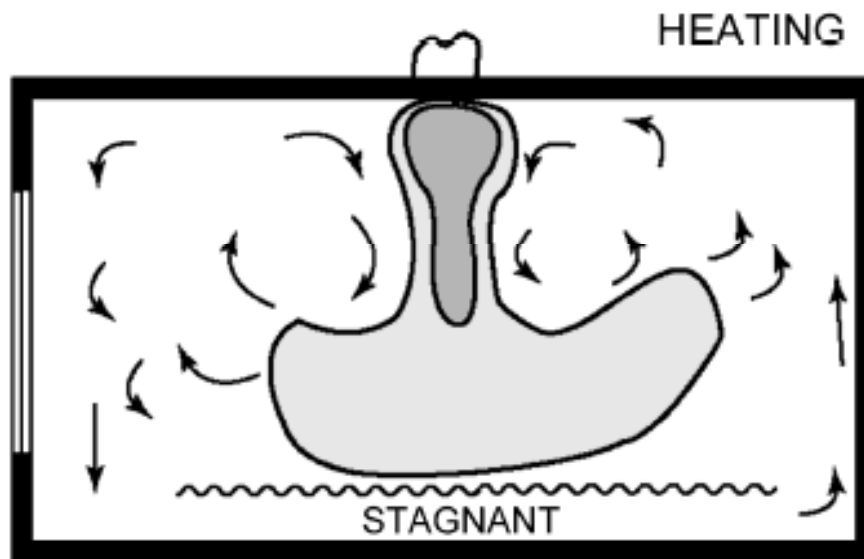
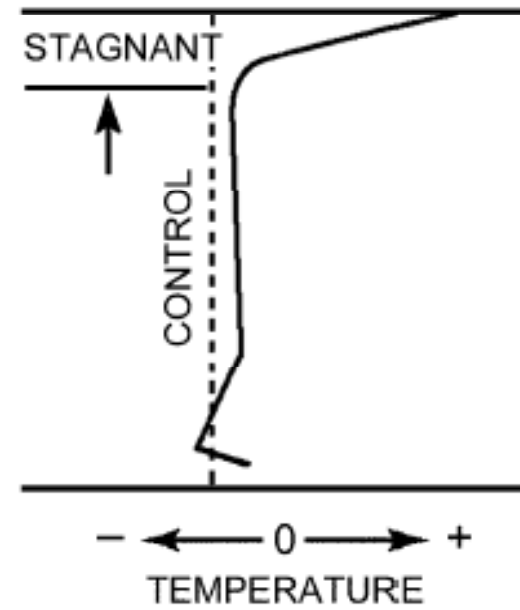
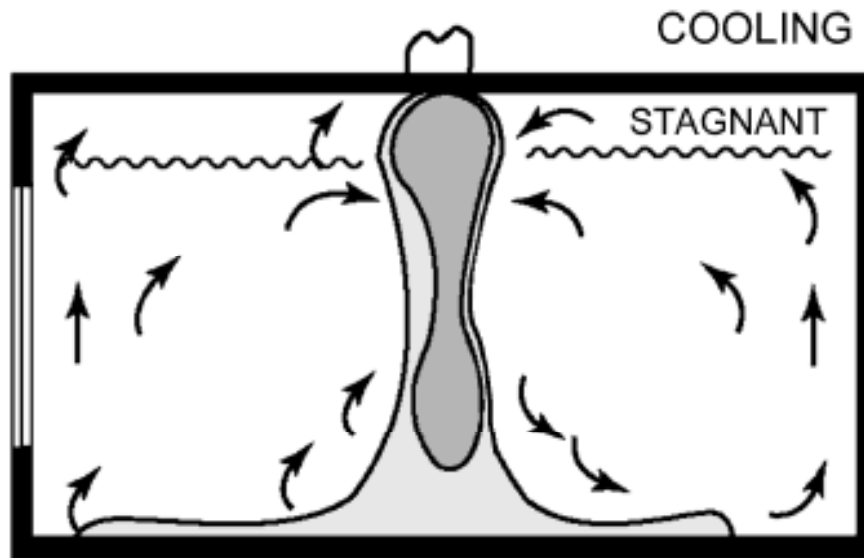

(Source: ASHRAE Handbook Fundamentals 2001)

Mixing Flow

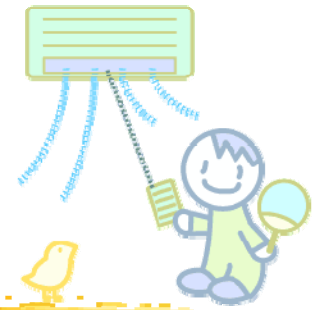

- Common types & locations of outlets
 - High side outlets
 - Ceiling diffusers
 - Slot diffusers
 - Sill and floor outlets
 - Outlets from stratified mixing flow
- Key questions for designers
 - Will the air jet enter the occupied zone?
 - Will stagnant zone be formed?

Will the air jet enter the occupied zone? Will stagnant zone be formed?

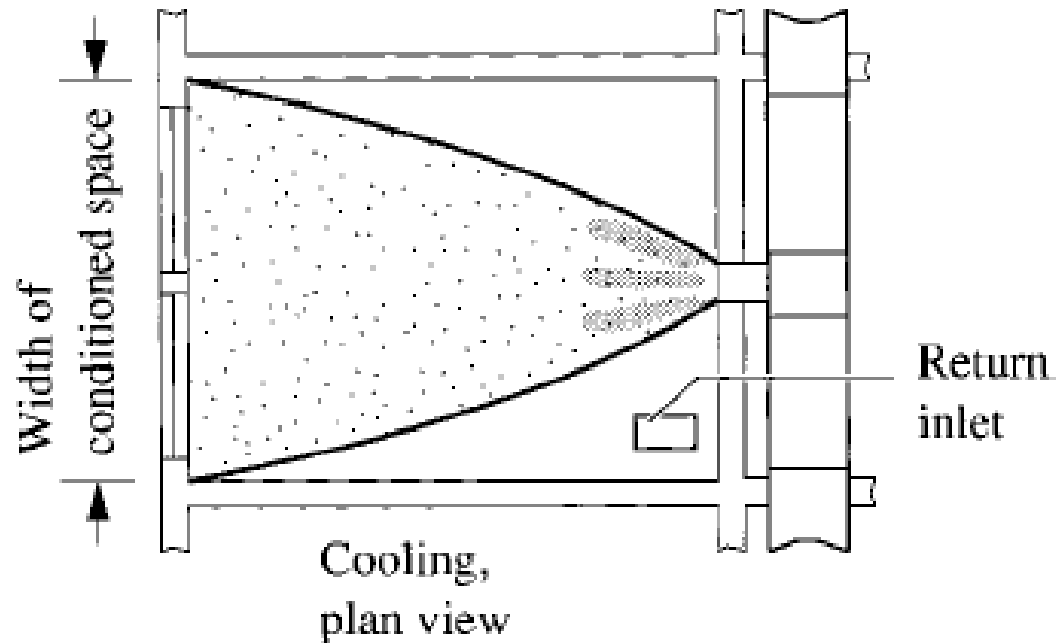
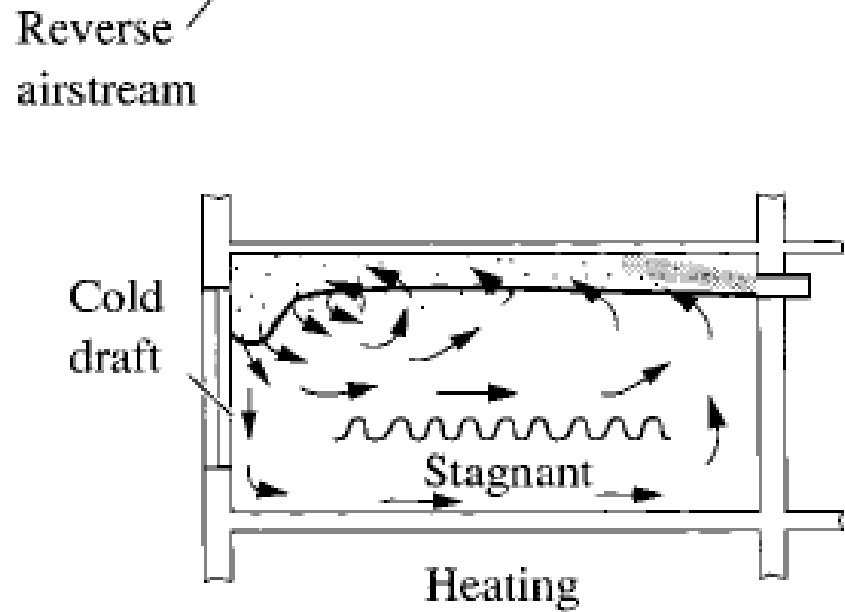
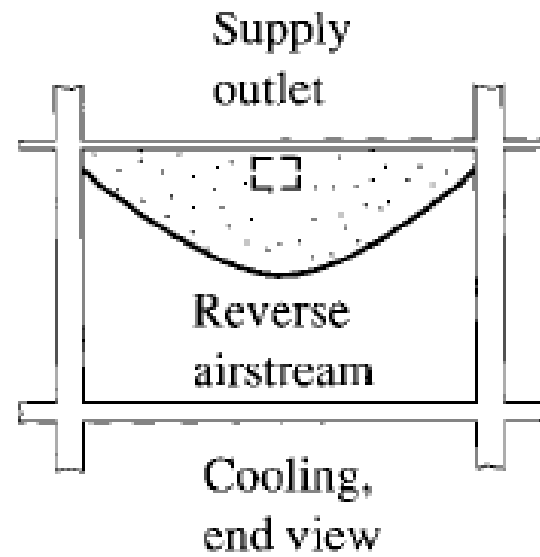
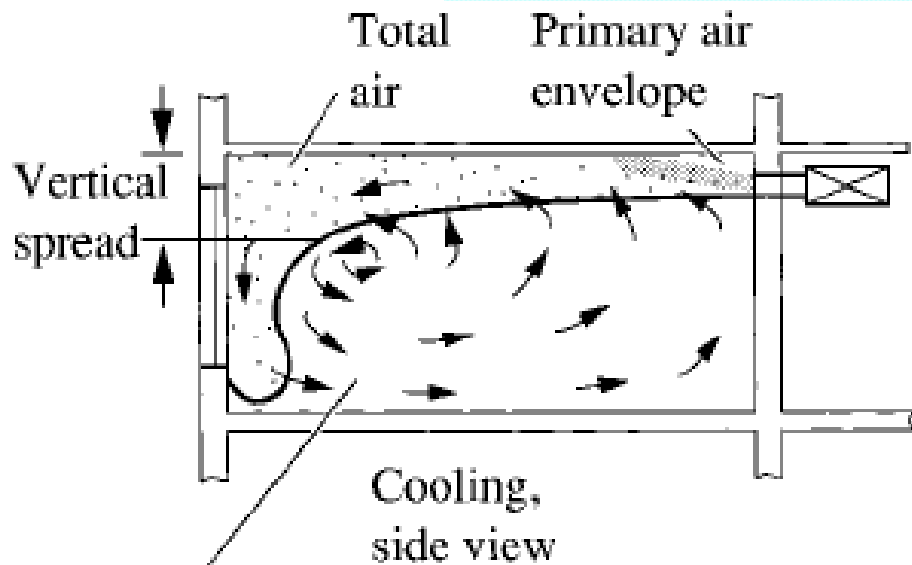

Mixing flow using high side outlets

(Source: Wang, S. K., 2001. Handbook of Air Conditioning and Refrigeration)

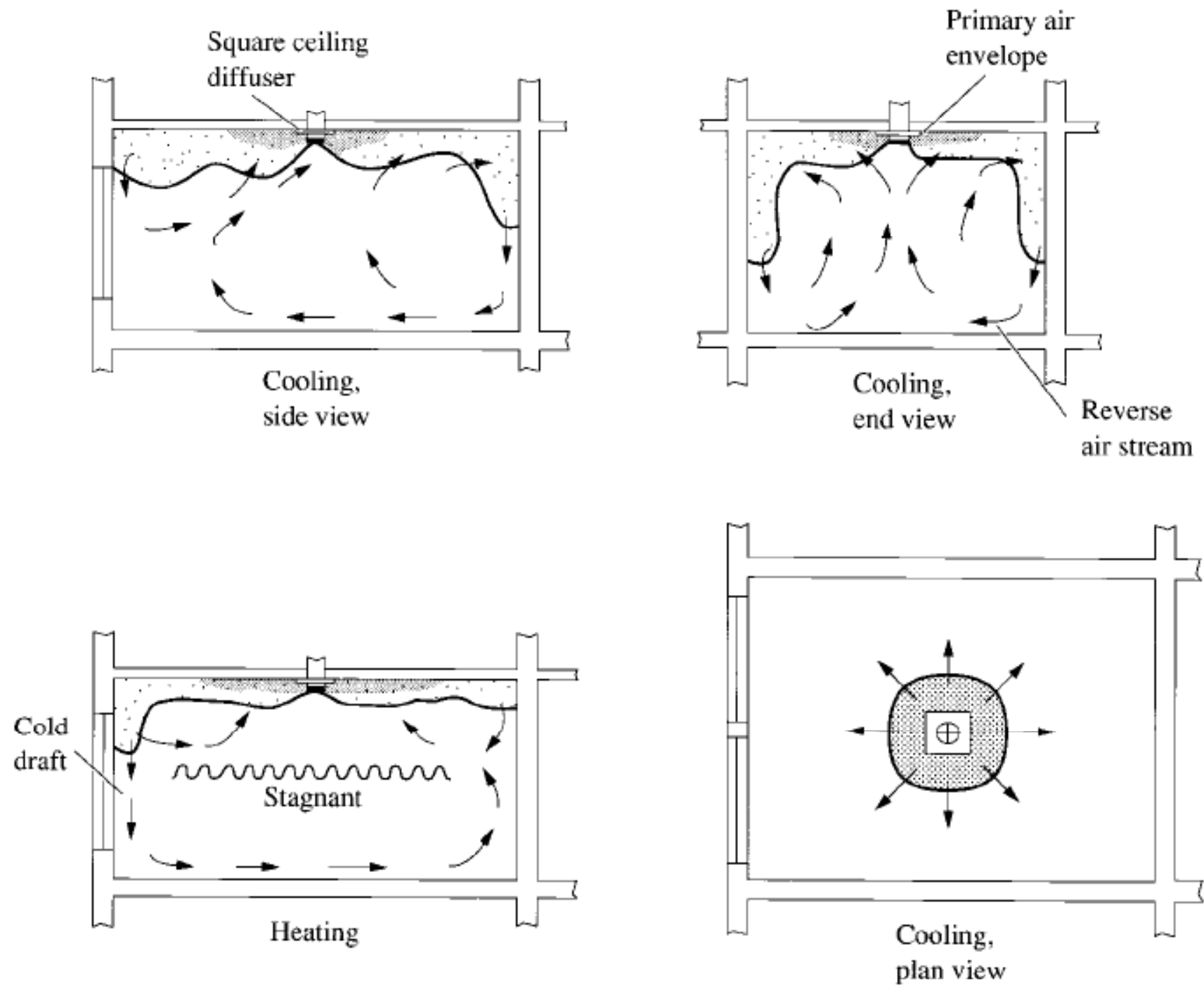

Mixing flow using ceiling diffusers

(Source: Wang, S. K., 2001. *Handbook of Air Conditioning and Refrigeration*)

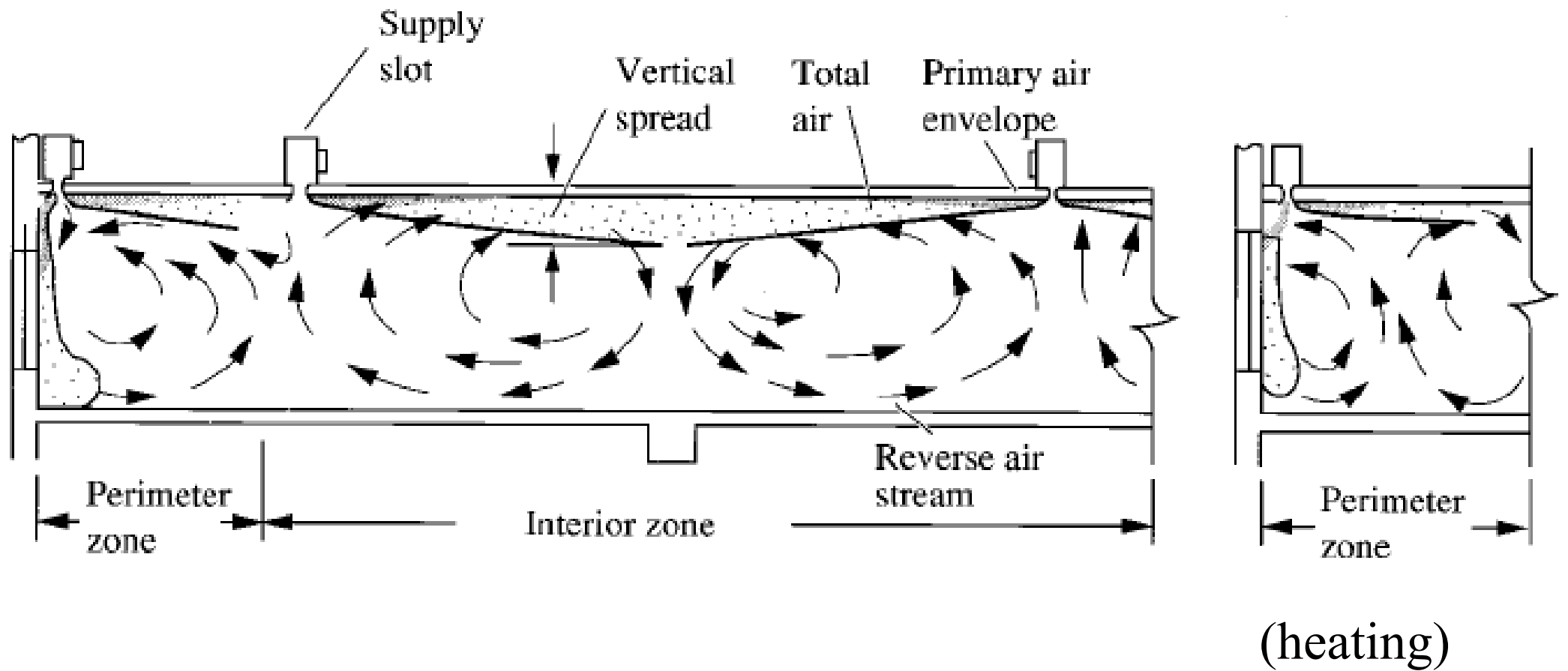

Mixing flow using slot diffusers

(Source: Wang, S. K., 2001. *Handbook of Air Conditioning and Refrigeration*)

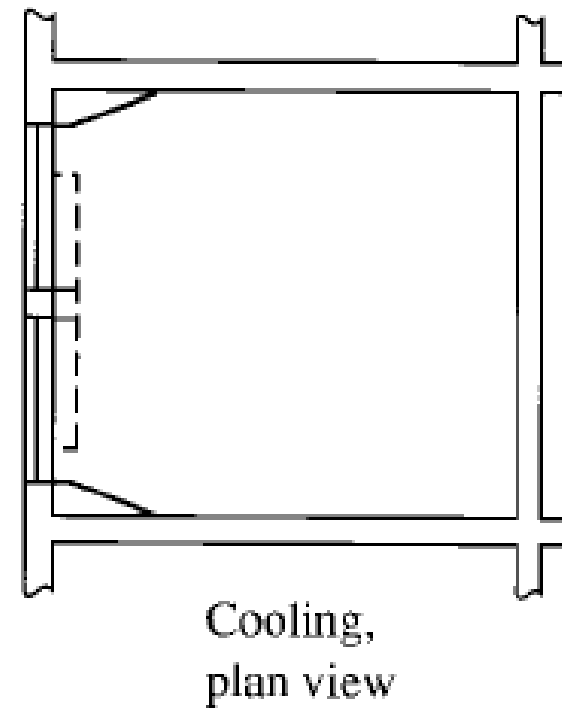
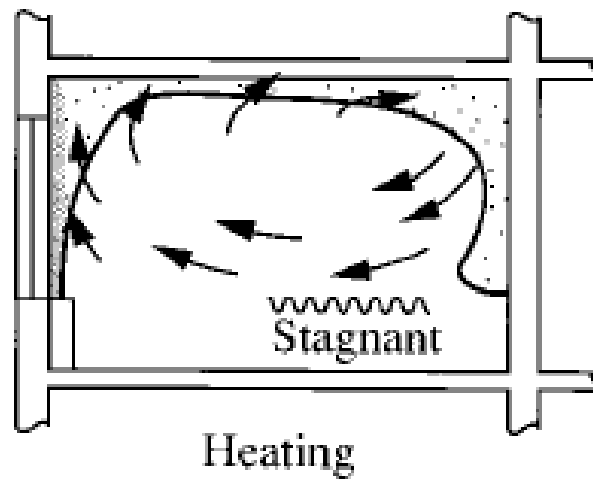
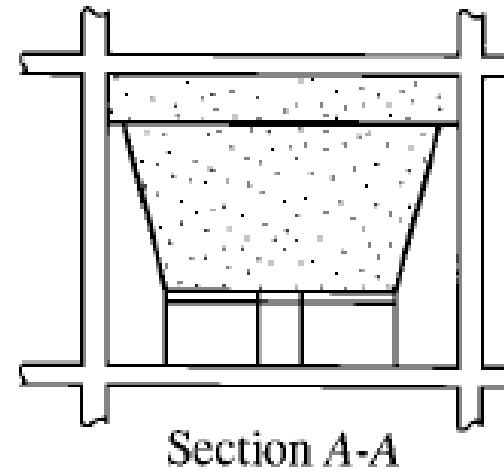
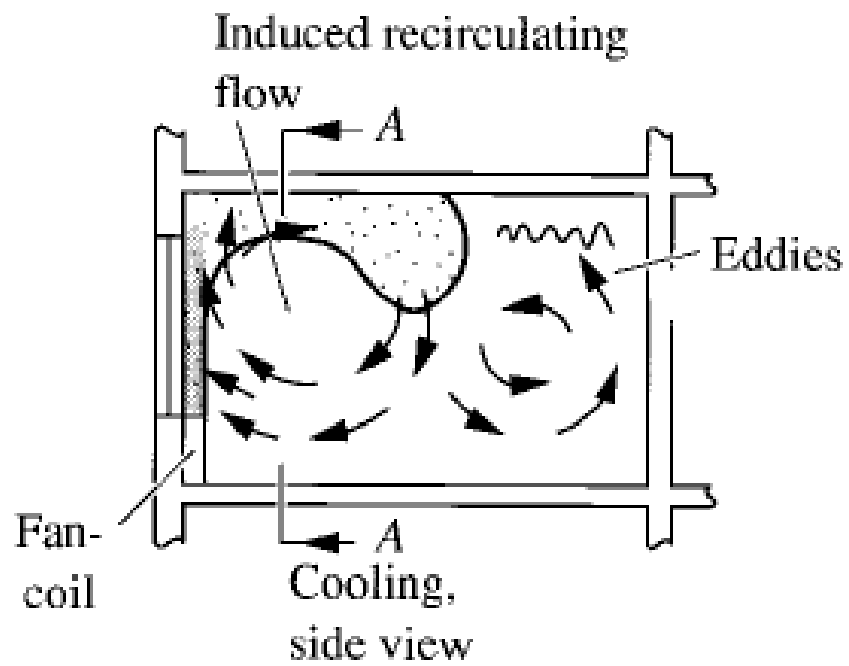

Mixing flow using sill outlet

(Source: Wang, S. K., 2001. Handbook of Air Conditioning and Refrigeration)

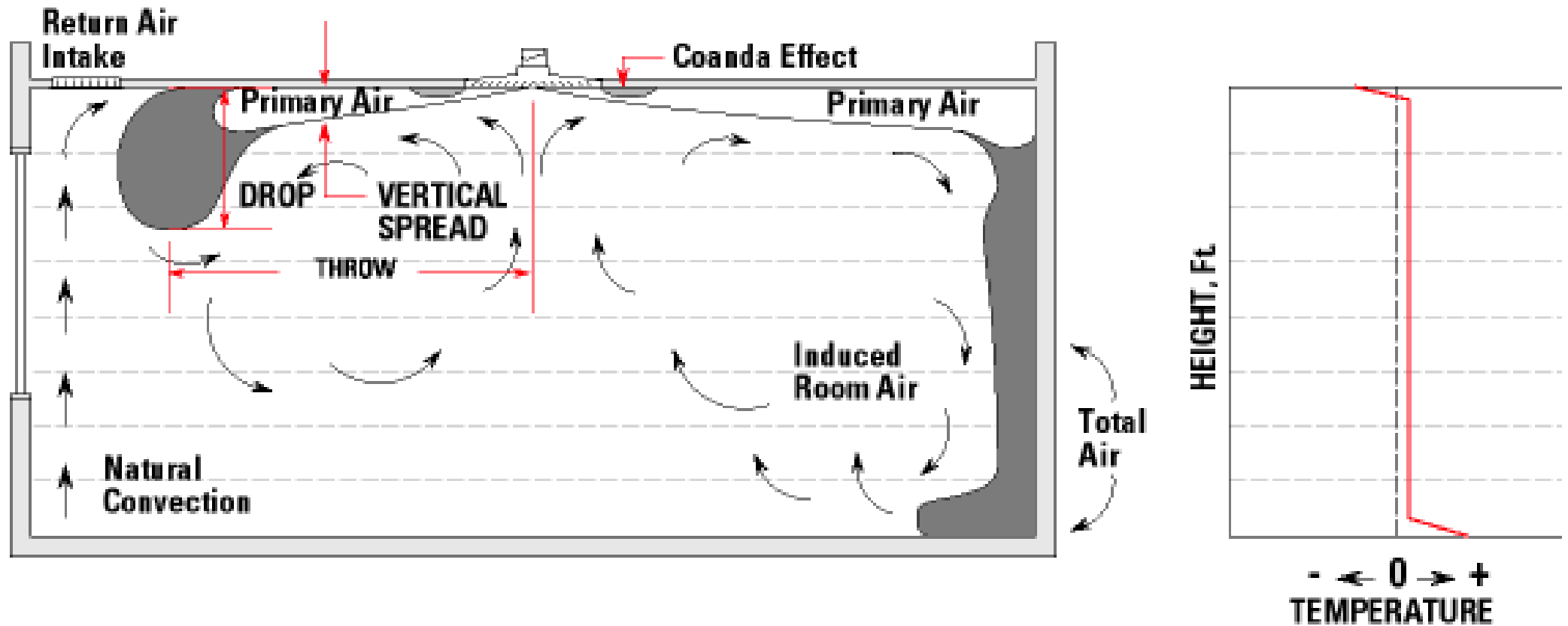

Space air diffusion with overhead cooling

(Source: <http://www.price-hvac.com>)

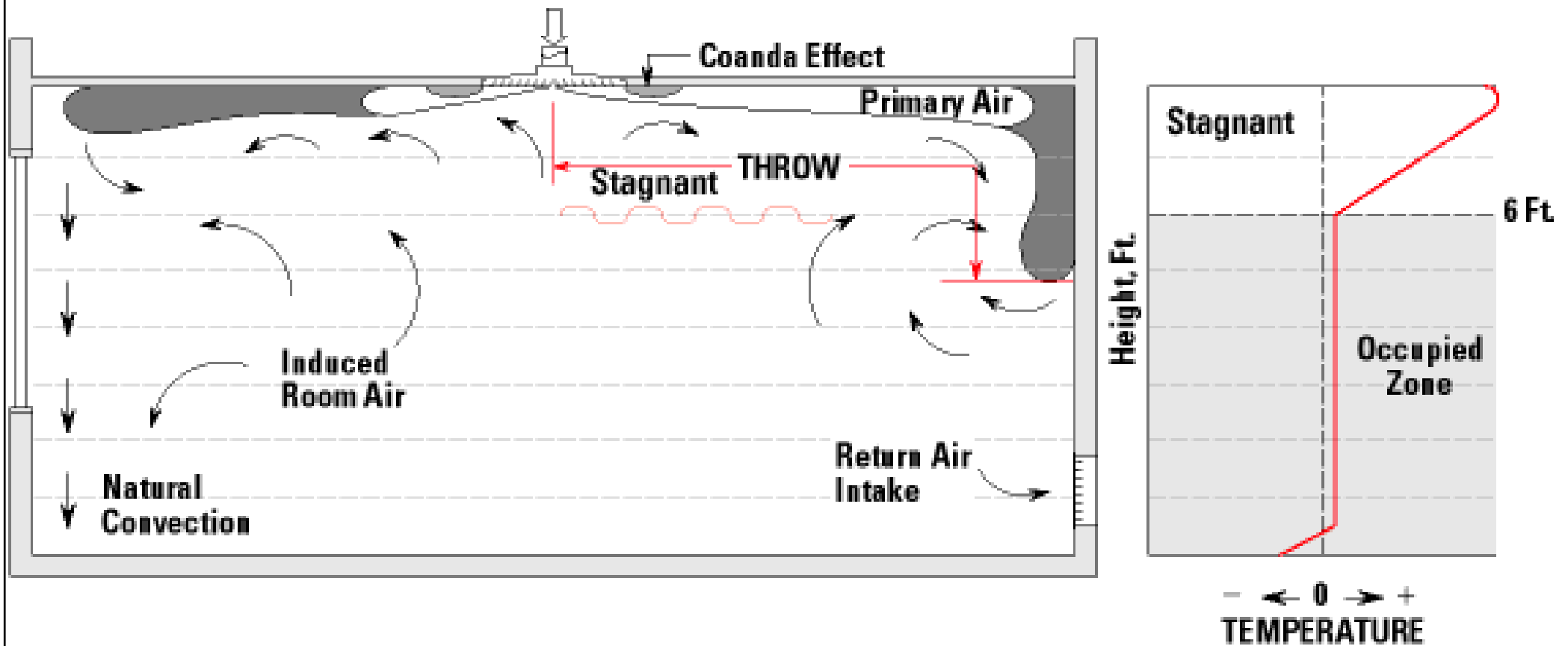

Space air diffusion with overhead heating

(Source: <http://www.price-hvac.com>)

Mixing Flow

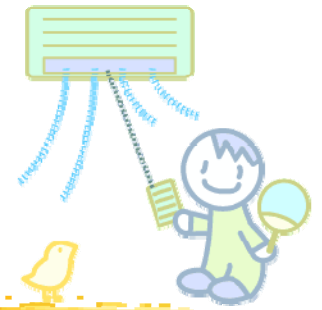

- In buildings with high ceiling
 - More economical to stratify the air vertically into zones during cooling
 - Upper boundary of the lower zone is at the level of the supply outlet where air jet projects horizontally
 - Examples:
 - Stratified mixing flow in a nuclear plant
 - Large, high-ceiling indoor stadium (w/ supply nozzles)
 - Chek Lap Kok Airport

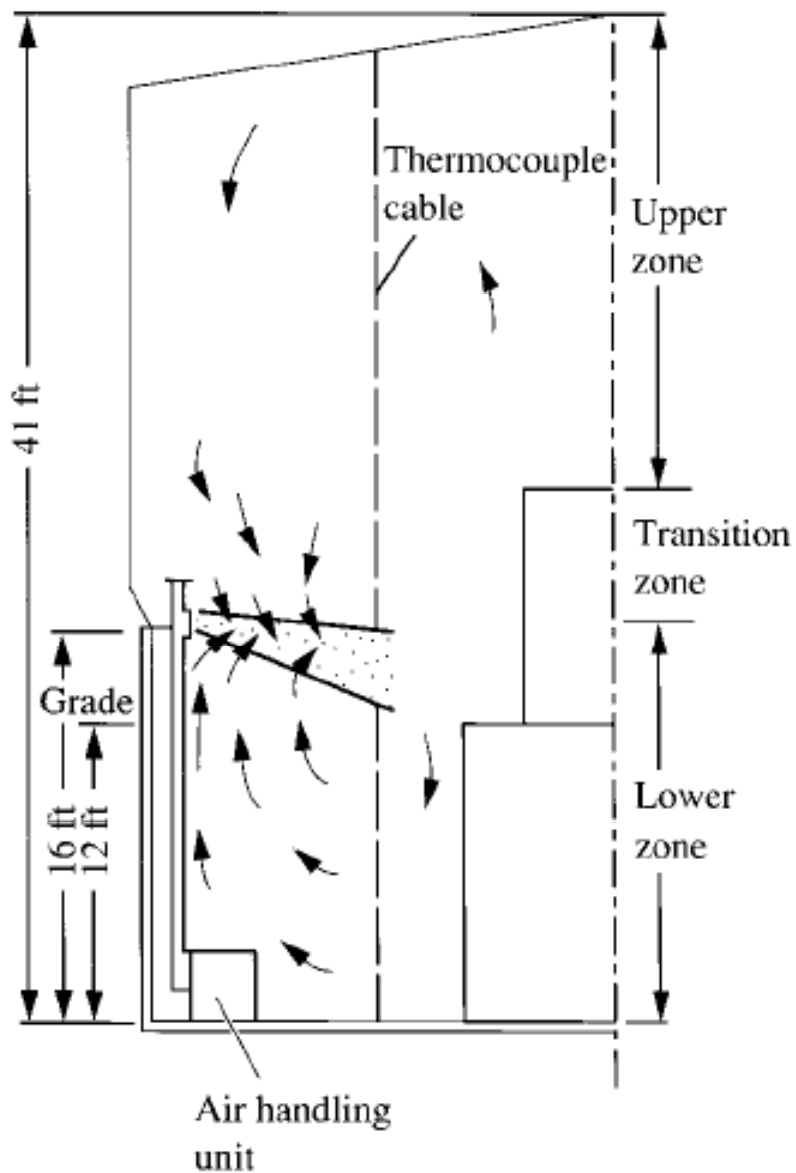

During cooling

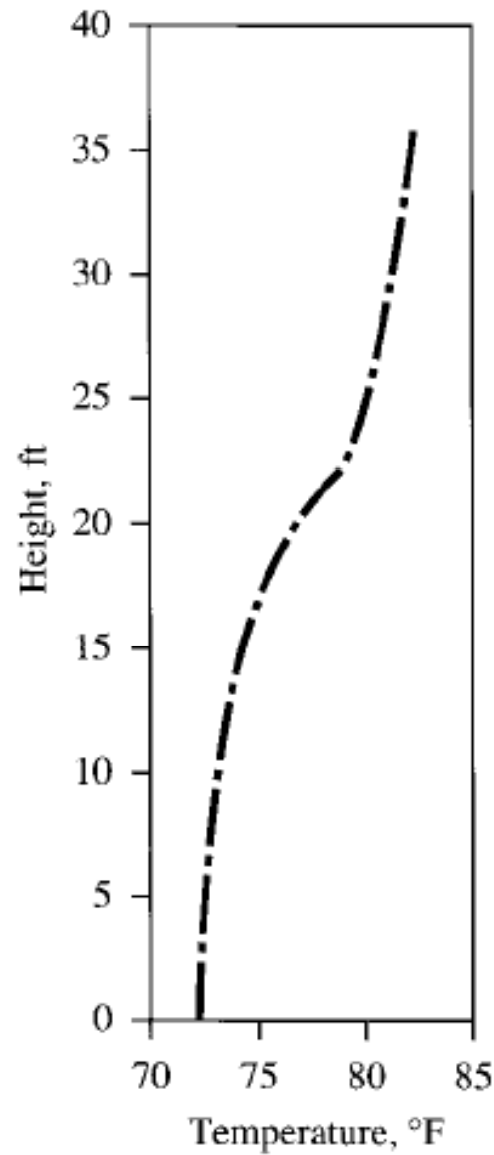

During heating

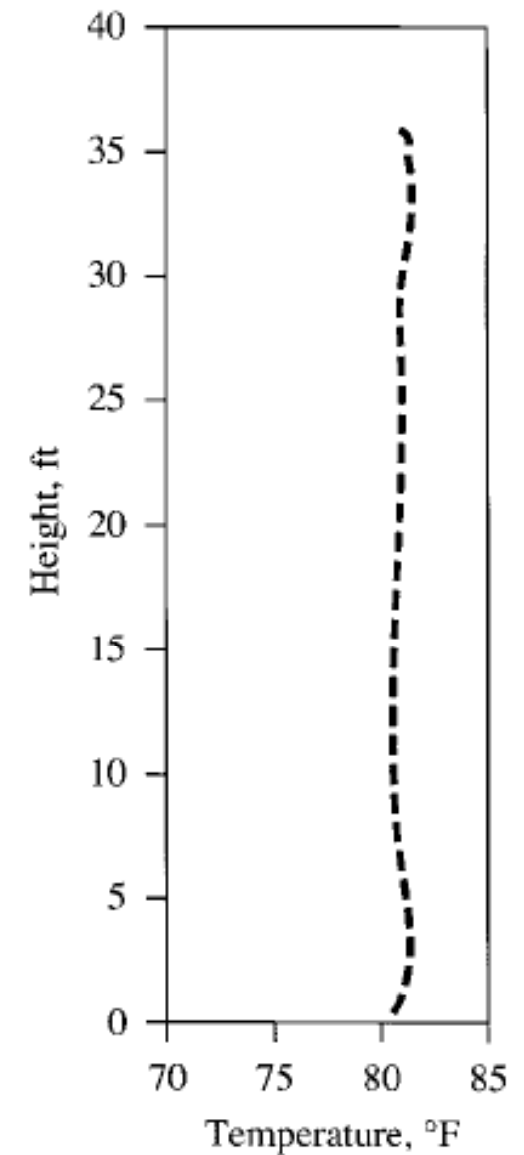

Stratified mixing flow in a nuclear facility

(Source: Wang, S. K., 2001. Handbook of Air Conditioning and Refrigeration)

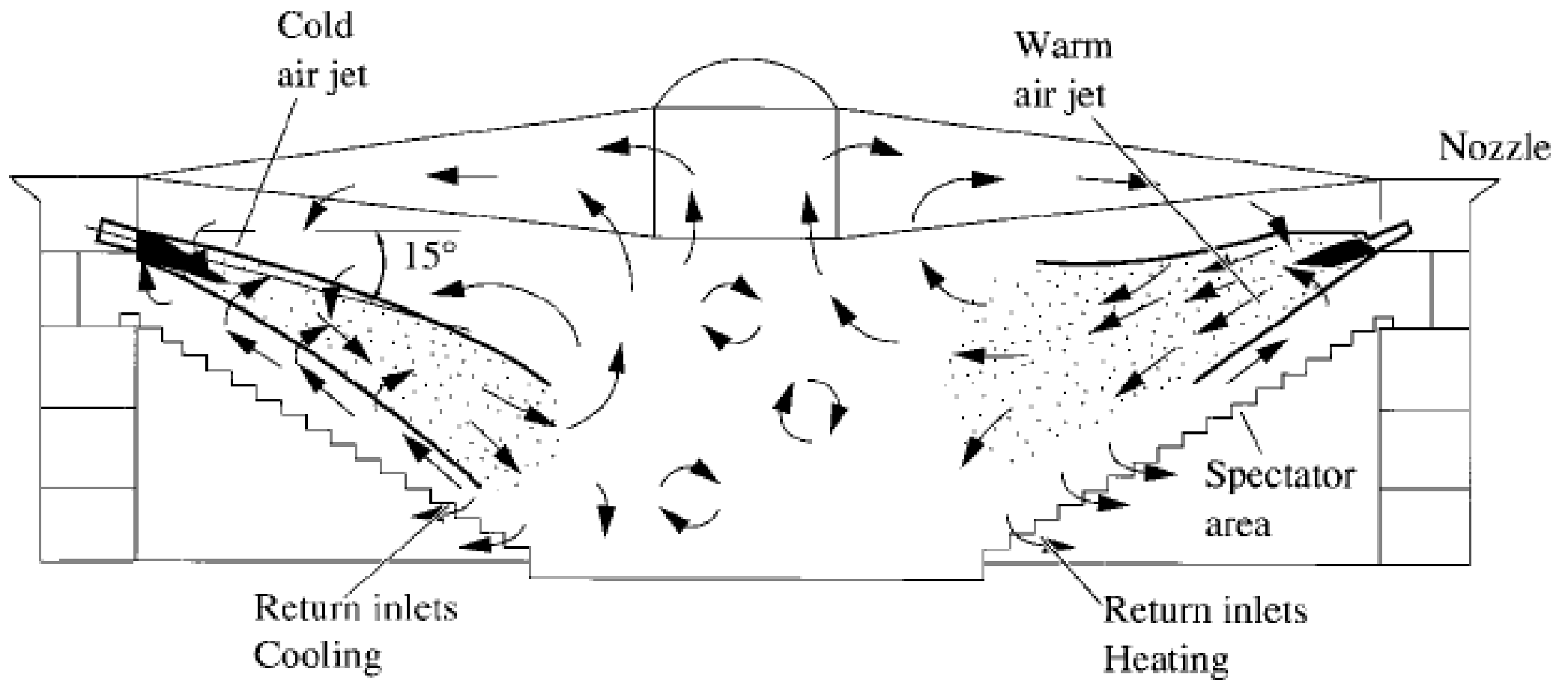

Stratified mixing flow in a large indoor stadium using supply nozzles

(Source: Wang, S. K., 2001. *Handbook of Air Conditioning and Refrigeration*)



Hong Kong International Airport

Mixing Flow

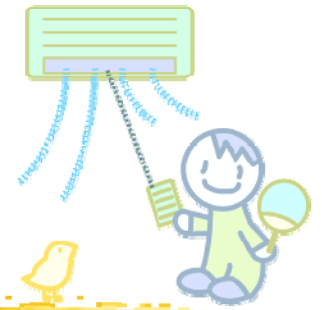

- Characteristics of stratified mixing flow
 - Convective heat transfer from hot roof is blocked
 - Cooling loads in lower zone is offset by supply air
 - Radiant heat from roof, wall & lights in upper zone enters the occupied zone and becomes cooling load
 - Although supply airflow rate & temp. affect the throw & drop of the air jet, the induced recirculating airflow patterns in upper & lower zones remain the same
 - Height of supply air jet determines upper boundary of the lower zone
 - Location of return inlets influences cooling load only when they are located in the upper zone

Mixing Flow

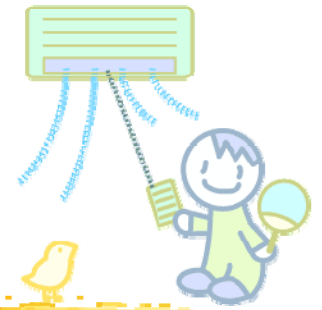

- Design & selection method
 - Review the form & use of the space, and determine if cooling or heating will be provided
 - Determine the amounts of airflow rates
 - Decide location for equipment
 - Obtain & review equipment catalogues (find acceptable styles & models of air terminals)
 - Lay out rough locations for air terminals
 - Select specific models & sizes

Mixing Flow



- Design & selection method (cont'd)
 - Check performance criteria (patterns, throws, sound levels, pressure drops)
 - Relocate, reselect, recheck if needed
 - Select any terminal boxes, size & lay out branch ductwork
 - Prepare schedules, drawings & specifications
 - Coordinate with other consultants (e.g. architect, interior designer)

Mixing Flow

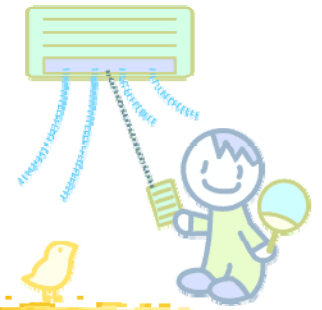

- Select type of supply outlet
 - Requirements of indoor environmental control
 - Such as precise air movement & air temperature
 - Shape, size, and ceiling height of the building
 - Surface effect
 - Volume flow per unit floor area
 - Determine the number of outlets
 - Appearance
 - Cost

Table 1 Guide to Use of Various Outlets

Type of Outlet	Air Loading of Floor Space, Max. L/s per m²	Approx. Max. Air Changes per Hour for 3 m Ceiling
Grille	3 to 6	7
Slot	4 to 10	12
Perforated panel	5 to 15	18
Ceiling diffuser	5 to 30	30

[Source: *ASHRAE Handbook HVAC Systems & Equipment 2000*, Chapter 17]

**Table 4 Air Diffusion Performance Index (ADPI)
Selection Guide**

Terminal Device	Room Load, W/m ²	$T_{0.25}/L$ for Maximum ADPI	Maximum ADPI	For ADPI Greater than	Range of $T_{0.25}/L$
High sidewall grilles	250	1.8	68	—	—
	190	1.8	72	70	1.5–2.2
	125	1.6	78	70	1.2–2.3
	65	1.5	85	80	1.0–1.9
Circular ceiling diffusers	250	0.8	76	70	0.7–1.3
	190	0.8	83	80	0.7–1.2
	125	0.8	88	80	0.5–1.5
	65	0.8	93	90	0.7–1.3
Sill grille, straight vanes	250	1.7	61	60	1.5–1.7
	190	1.7	72	70	1.4–1.7
	125	1.3	86	80	1.2–1.8
	65	0.9	95	90	0.8–1.3
Sill grille, spread vanes	250	0.7	94	90	0.6–1.5
	190	0.7	94	80	0.6–1.7
	125	0.7	94	—	—
	65	0.7	94	—	—
Ceiling slot diffusers (for T_{10}/L)	250	0.3	85	80	0.3–0.7
	190	0.3	88	80	0.3–0.8
	125	0.3	91	80	0.3–1.1
	65	0.3	92	80	0.3–1.5
Light troffer diffusers	190	2.5	86	80	<3.8
	125	1.0	92	90	<3.0
	65	1.0	95	90	<4.5
Perforated, louvered ceiling diffusers	35–160	2.0	96	90	1.4–2.7
				80	1.0–3.4

[Source: *ASHRAE Handbook Fundamentals 2001*, Chapter 32]

Mixing Flow

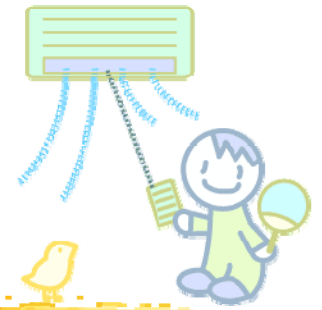

- Select & check the specific supply outlet
 - Major parameters
 - Sound level
 - Combined sound level shall be at least 3 dB lower than the recommended NC criteria
 - Typical air velocities: 2.5 to 6.25 m/s
 - Drop of cold air jet
 - Will cold air jet enter the occupied zone?
 - Total pressure loss
 - Typically, total pressure loss shall be lower than 50 Pa

Mixing Flow

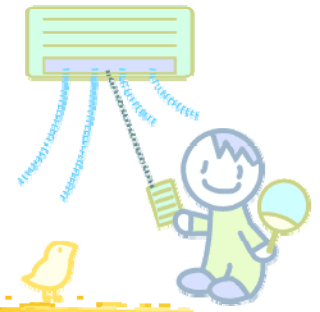

- Determination of the final layout is often an iteration process
- Some good practices for return inlets:
 - If a ceiling plenum is used as return plenum, return inlets shall be located outside supply air jet, above return airstream, or near a concentrated heat source
 - Recommended face velocities for return inlets:
 - Above occupied zone: 4 to 5 m/s
 - Within occupied zone: 2 to 3 m/s
 - Door louvres: 1.5 to 2.5 m/s

Further Reading



- **Reference Books:**

- *ASHRAE Handbook Fundamentals 2009, Chp. 20*
- *Designer's Guide to Ceiling-based Air Diffusion*
- *Handbook of Air Conditioning and Refrigeration, 2nd ed., Chp. 18*

- **Web Links:**

- <http://www.price-hvac.com>
 - Engineering Guides: Air Distribution and Terminal Unit
 - Training Modules: Basics of HVAC, Comfort Criteria, Space Air Diffusion, Air Outlet Selection