

MEBS6008 Environmental Services II

<http://www.hku.hk/mech/msc-courses/MEBS6008/index.html>



Sea Water Heat Rejection System



Department of Mechanical Engineering
The University of Hong Kong

Content



Sea water heat rejection System

- Sea Water Characteristics & Hong Kong Environment
- What are the Systems - Two Options
- Advantages of Using Sea Water Systems
- Problems and Solutions in using Sea Water Heat Rejection
- Centralised Piped Supply System for Condenser Cooling (CPSSCC)



Sea Water Characteristics

Salinity

This is approximately equal to the weight in grams of dry salts contained in 1 kg of sea water expressed in ‰ (parts per thousand).

$$\text{Chlorinity} = (\text{Cl}^- + \text{Br}^- + \text{I}^-)$$

$$\text{Salinity} = 0.03 + 1.805 (\text{chlorinity})$$

Salinity range : 33 - 38 ‰ (35 ‰ for open ocean water)

Chlorinity range : 18 - 20 ‰

The relative proportions of the major constituents of sea water are virtually constant.

For open sea water at $S \text{ ‰} = 35.00$:

Sea Water Characteristics



<u>Ion</u>	<u>g/kg</u>
Total salts	35.1
Sodium	10.77
Magnesium	1.30
Calcium	0.409
Potassium	0.338
Strontium	0.010
Chloride	19.37
Sulphate as SO ₄	2.71
Bromide	0.065
Boric acid as H ₃ BO ₃	0.026



Sea Water Characteristics

Acidity

The acidity is indicated by the pH value.

Acidic if $\text{pH} < 7$

Alkaline if $\text{pH} > 7$

Sea water is normally alkaline:

At top layer, $8.1 \leq \text{pH} \leq 8.3$

In ocean depths, $\text{pH} < 8.0$ (because of effect of pressure)

In inshore localities, pH is lower if hydrogen sulphide abounds
pH is higher if plants abound

Temperature effects: pH drops if temperature increases unless the heat boils off the dissolved CO_2 .



Sea Water Characteristics

Dissolved Oxygen Concentrations

Dissolved oxygen concentration varies with

- temperature
- movement of sea water
- evaporation
- RH of ambient air

Dissolved gases:

≅ 8.0 ml/l for surface waters in Arctic

≅ 4.5 ml/l for surface waters in the Tropics



Sea Water Characteristics

Turbidity (F.T.U.)

A measure of the concentrations of suspended solids in the sea water.

Biochemical Oxygen Demand - 5 Days

BOD₅ in ppm, used for assessment of level of pollution.

BOD₅ ≥ 5.0 ppm is an indication of biological pollution.

Total Caliform Count (Counts/100 ml)

This is a parameter used to indicate the level of sewage pollution.



Hong Kong Environment

Temperature

The temperature of sea water varies directly as the latitude:

– 2°C at the poles to 35°C on the equator subject to seasonal variations, winds and currents.

Salinity

About 32.1‰ at Tai Tam Bay and 25.4‰ at Kwun Tong and Tsuen Wan.

Higher salinity → higher concentrations of reactive ions
→ higher rate of corrosion



Hong Kong Environment

Acidity

pH \cong 8.1 at Tai Tam Bay
 \cong 7.5 - 8.0 elsewhere

Acidic water produces accelerated corrosion and pitting.

Dissolved Oxygen Concentration

\cong 89.5% at Tai Tam Bay
 \cong 10% at Kwun Tong

Higher dissolved oxygen concentration increases the corrosion rates of ferrous materials. But for stainless steels, this produces passivation due to formation of a protective film. For copper based alloys, the effect is conditional upon whether a protective film is formed.



Hong Kong Environment

Turbidity

≅ 2.8 FTU at Tai Tam Bay

≅ 5.0 FTU at Kwun Tong

Higher turbidity → more suspended solids
→ increased erosion

Biochemical Oxygen Demand - 5 Days

BOD₅ ≅ 1.5 ppm at Tai Tam Bay

BOD₅ ≅ 28 ppm at Kwun Tong and Tsuen Wan

Higher BOD₅ → higher probability of biological corrosion

Hong Kong Environment



Total Caliform Count

- ≅ 26 counts/100 ml at Tai Tam Bay
- ≅ 4×10^4 counts/100 ml at Kwun tong

Higher BOD₅ indicates extensive biological activities in sea water. Hence higher probability of biological corrosion.

Temperatures

≅ 25.5°C at Tai Tam Bay in June and along Victoria Harbour

Higher temperatures → higher corrosion rates

What are the Systems?

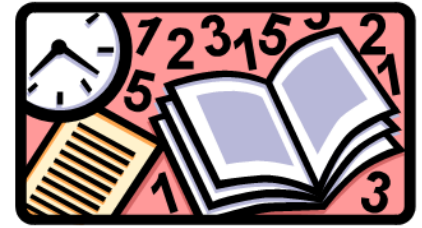

Seawater is used for cooling and dissipation of exhausted heat for the two chiller plants.

Seawater is distributed to the chiller plants using a dedicated pipe network served by a seawater pumphouse.

The location of the pumphouse has been identified at the waterfront.

There are normally several pumps inside the pump house.

Two Options -

Once through direct sea water heat Rejection System

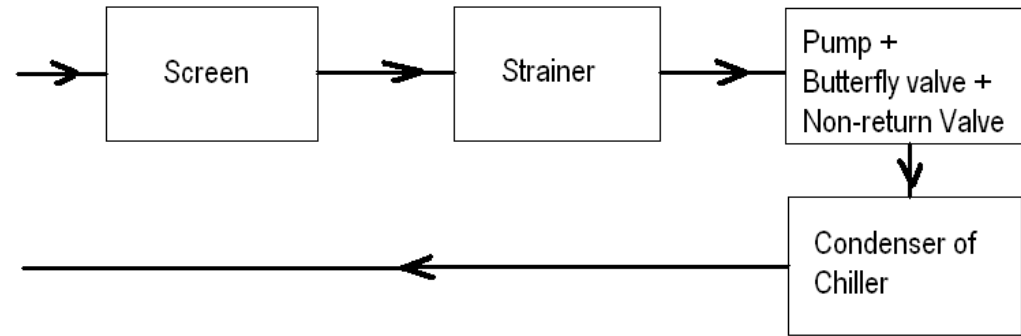
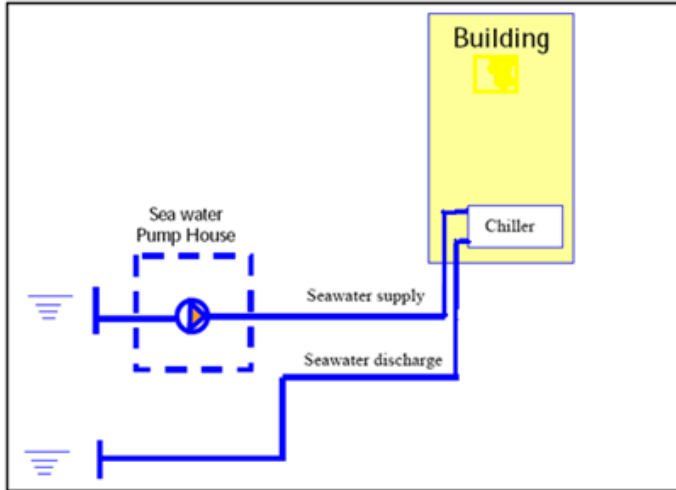

Once through Direct Sea Water cooling

- Tube and shell type condenser of chiller only
- Seawater to cool and condense refrigerant and then discharged through pipeworks back to sea

Two Options - Once through indirect sea water heat Rejection System

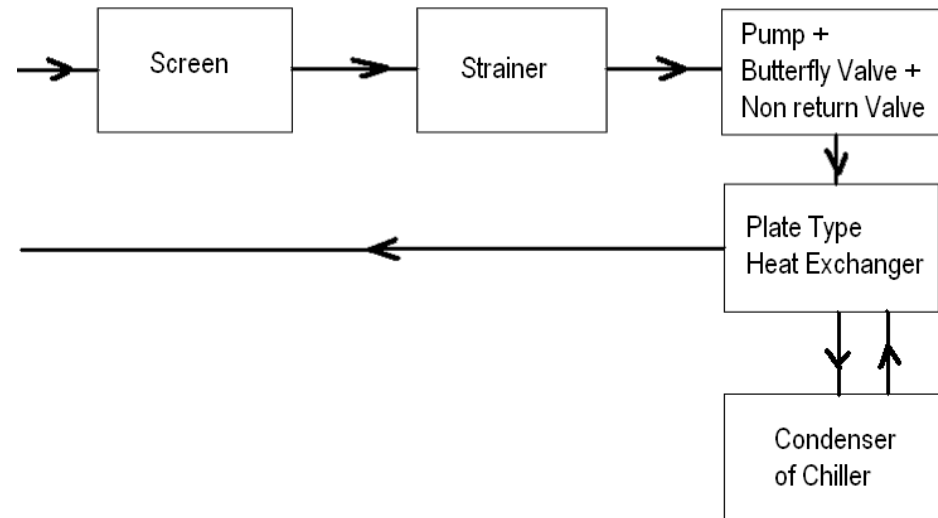
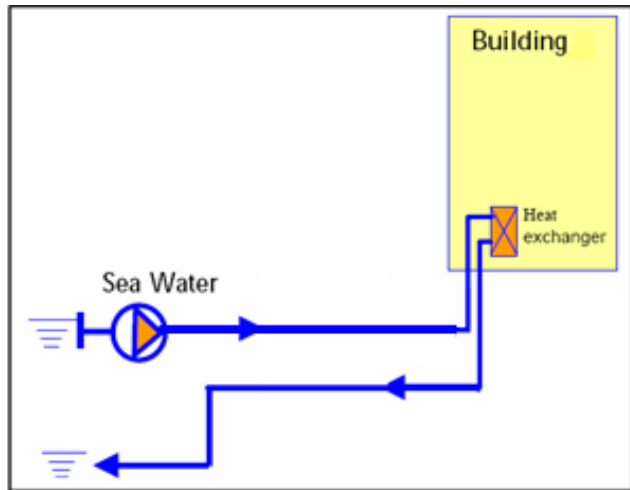
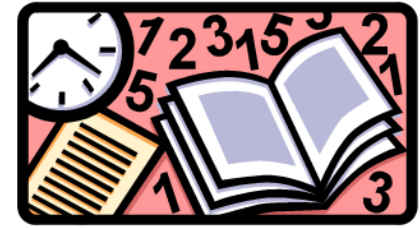

Once through indirect sea water heat Rejection System

- Plate type heat exchanger is added
- Fresh-water is cooled by seawater in plate heat exchanger, then passed to the condenser of chiller and re-circulates.
- Seawater is discharged after passing through plate heat exchanger.

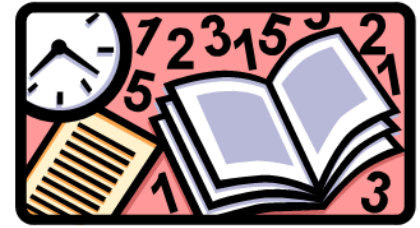

What are the Systems?

EXISTING ϕ 500 SEA WATER PIPES
OUTSIDE PUMP HOUSE
SERVING KOWLOON GOVERNMENT
OFFICES

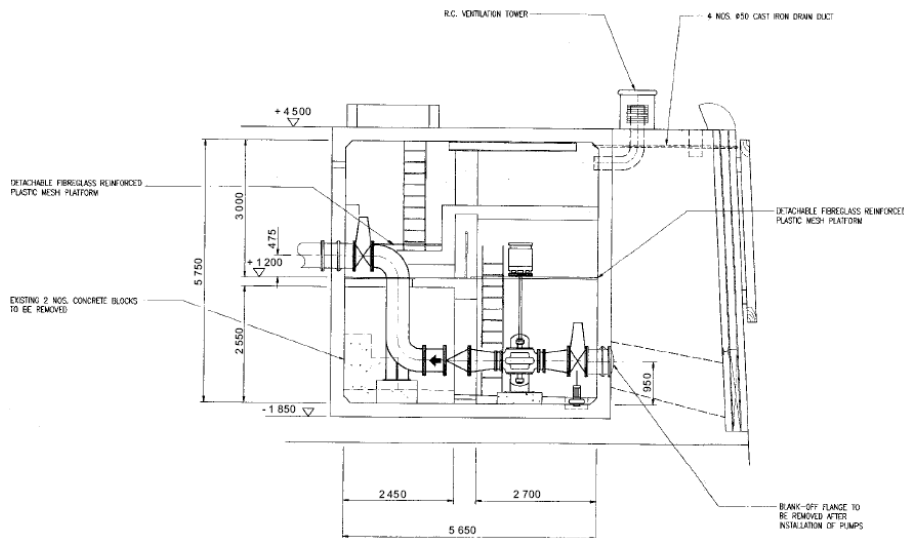
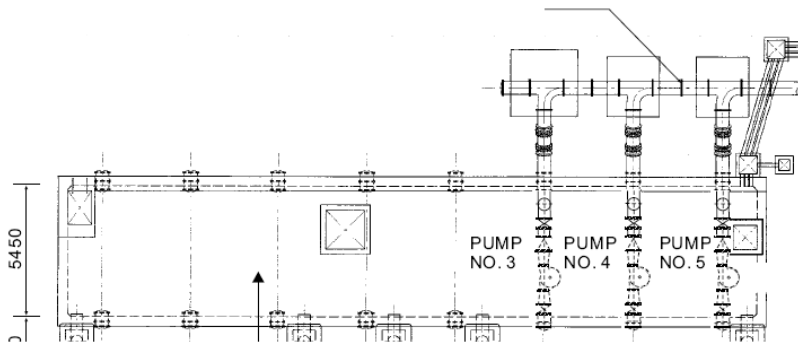

Seawater intakes are near bottom of sea walls

Settlement chambers at intake to reduce entry of suspended solids

Flat mesh screens mounted beside intakes for primary filtration (to reduce cleaning frequency).

After primary filtration, seawater will be pumped through pipelines to building plant rooms

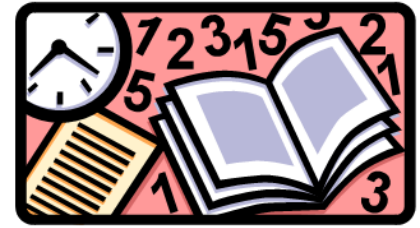

What are the Systems?



- For buildings which are relatively far from sea water intakes, small pump houses are situated right beside sea walls that are usually located below ground level.
- Long suction pipelines running across road and pedestrians
- Booster pumps are often required.
- Before entering condensers in plant room, seawater will pass through a secondary filtration system (strainers).



Advantages of Using Sea Water Systems

- Sea Water is easily available along the coastal regions
- The higher first equipment and installation cost are far outweighed by the lower operating cost in electricity.



Minimum COP for Air-Cooled Water Chiller with Centrifugal Compressors

Capacity Range (kW)	All Ratings
Minimum COP (Cooling)	2.8

Minimum COP for Water-Cooled Water Chiller with Centrifugal Compressors

Capacity Range (kW)	Above 1000
Minimum COP (Cooling)	5.7

Advantages of Using Sea Water Systems

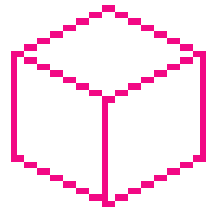

- Shortage of space for installation of air cooled heat rejection system. The condenser occupies the least amount of space

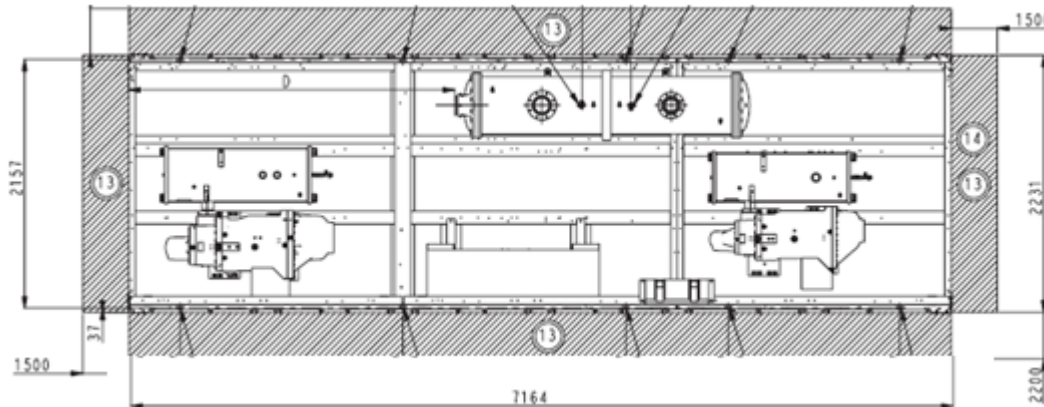

700 kW Air Cooled Chiller
(Long side overall length = 7.2m)

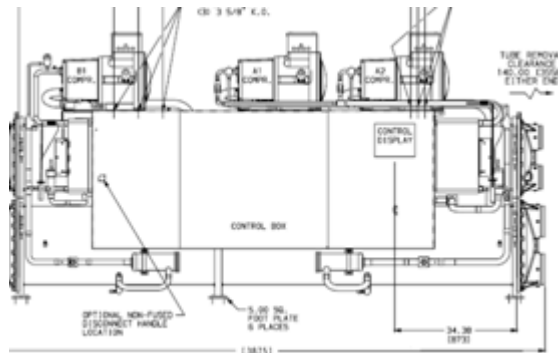

700 kW Water Cooled Chiller
(Long side overall length = 3.8m)

Advantages of Using Sea Water Systems

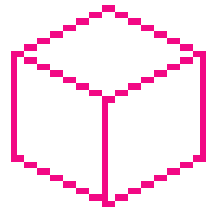

- No noise problems which is incurred by **high air flow** in the air cooled systems.

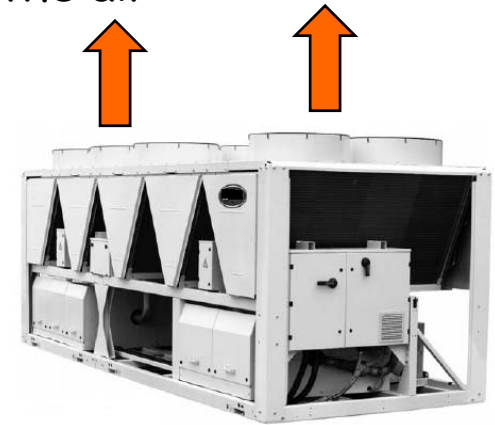

- Problem associated with the use of **cooling tower**
 - Mist in operating of cooling tower
 - Legionnaires diseases in operation of cooling tower
 - Suspension of water supply from WSD



Problems and Solutions in using Sea Water Heat Rejection



Only preferred to location at which is very close to the sea.



Problems and Solutions in using Sea Water Heat Rejection



Bio-fouling

Intake of debris and large organism into the system

Traditional mesh screens + secondary screens to remove

- seaweeds,
- debris
- large-size matured organisms.



seaweeds



debris



Problems and Solutions in using Sea Water Heat Rejection

Bio-fouling

Screening systems cannot prevent the passage of

- spawn (魚等的)卵;幼苗
- mussels (貽貝) and
- barnacles 藤壺(一種甲殼類動物)

entering that attach to the walls of the water boxes.

The steady stream of relatively slow-moving water supplies food and oxygen for their growth.



Marine blue mussel



Barnacles



Corrosion caused partly by barnacles



Bio-fouling



- Deposition of large quantities of microbes on surfaces in contact with the seawater so that formation and development of bio-films on the surfaces.
- The attachment of larvae of invertebrates, mussels and the spores of marine algae settling and growing on submerged surface.



Bio-fouling



- Reduction in flow rate
- Deterioration of heat transfer rate
- Increase erosion and corrosion caused by cavitation around fouling build-up

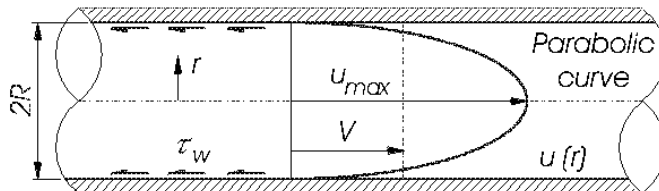

Problems and Solutions in using Sea Water Heat Rejection



Bio-fouling Treatment

- Application of chlorination and/ or biocides to kill small size organisms such as spawn, mussels and barnacles.
- Chlorination by:
 - Dosing of chlorine gas (0.1 to 2 ppm)
 - Adding sodium hypochlorite solution



Chlorine gas in a transparent plastic container.

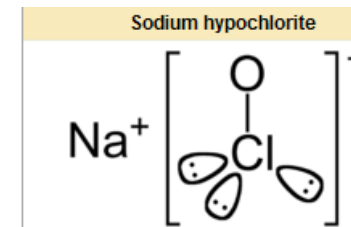

Problems and Solutions in using Sea Water Heat Rejection



Bio-fouling Treatment by Biocide

- It inhibits growth of marine organisms and inhibit the formation of scale and slime by acting as an efficient dispersant.
- Biocide treatment at a regular interval -whole system at 6-ppm biocide solution for approximate 1 hour (not continuous lower ppm - immunity built up)
- Advice of approved water treatment specialist shall be sought on the dosages required.
- Fixed sea water pumped quantities : metering pumps set for a particular input rate to achieve the appropriate dosage and duration. To pump biocide direct from its supply container.
- Variable pumping flows : metering pump/pumps to automatically vary the amounts of chemicals in accordance with actual sea water flow.



Problems and Solutions in using Sea Water Heat Rejection

Bio-fouling Treatment by Biocide

The ideal biocide for sea water condenser cooling systems : -

- Dispersing effect on deposits
- Filming properties providing a protective film to internal of pipe work
- pH value of 6.8
- Non-flammable
- Easily application by chemical metering pump with or without dilution
- Being sufficiently bio-degradable to avoid pollution (impact life of marine organism) and acceptable to the Environmental Protection Department

Problems and Solutions in using Sea Water Heat Rejection



Bio-fouling Treatment by Chlorination

- Chlorination by:
 - Using electro-chlorinator to produce hypochlorite ions by electrolysis of sea water



Typical Marine Growth Prevention System :

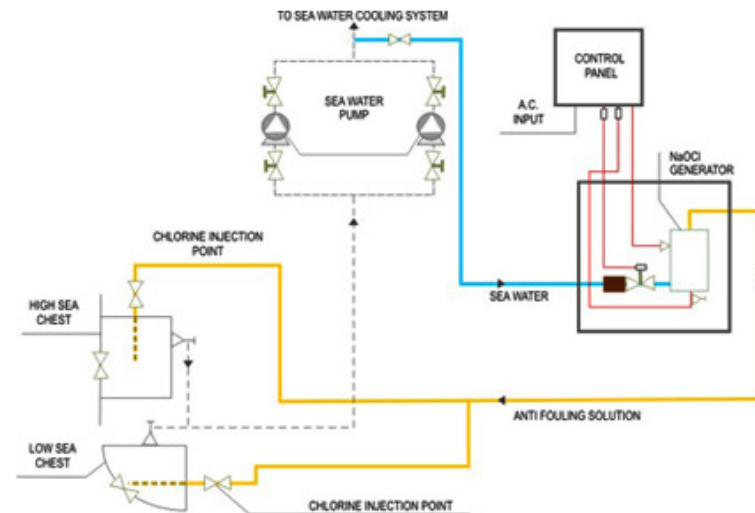

Problems and Solutions in using Sea Water Heat Rejection



Bio-fouling Treatment by Electro-chlorinator

- It produce and inject on-site sodium hypochlorite solution.
- Such system takes sea water in pump chamber and inject the solution back into the pump inlet side.
- Its operation interlocked to on/off of seawater pumps.
- Duplicate to allow one for 'off-line' maintenance.



Bio-fouling Treatment by Electro-chlorinator

- Electro-chlorinator designed for production & injection of on-site sodium hypochlorite solution.
- The operation of the electro-chlorinator shall be interlocked to work or stop as the seawater pumps.
- Duplicate electro-chlorinator plant shall be required to ensure continued treatment when one unit is 'off-line' for maintenance.
- The electrodes shall be made of high corrosion resistant material
- Integral safety facilities in the electrolytic cells : water flow switch and cell voltage imbalance detector to prevent build-up of hydrogen
- Vent to dilute and disperse the hydrogen gas from the degas tank

Problems and Solutions in using Sea Water Heat Rejection



Bio-fouling Treatment by Flow Control & Thermal Soak

- Maintaining a proper flow velocity to inhibit settlement of fouling organisms
- Velocity greater than 1.5 m/s can inhibit settling of various fouling organisms
- Application of thermal soak to kill fouling organisms. (Recycling of water through condenser until the water temperature reach a level that organisms cannot tolerate).

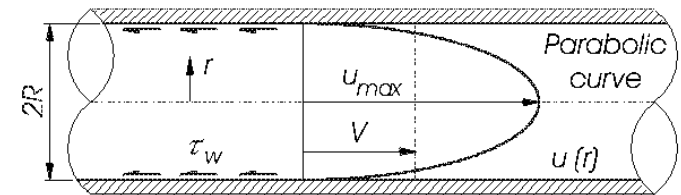



Problems and Solutions in using Sea Water Heat Rejection

Bio-fouling Treatment by Mechanical Cleaning

Brushes

- Traditional manual cleaning method of pushing long handled brushes through condenser tubes



High pressure water gun

- New method includes the use of high-pressure water gun to force special tube cleaner down the tubes to scrape scale and force debris out the outlet end.



Water Gun



Tube Cleaner

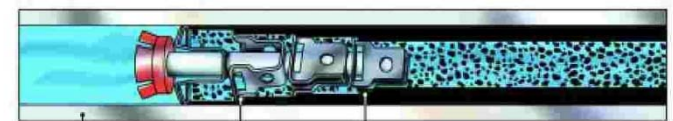

Tube Wall Cleaner Blades Deposits

Problems and Solutions in using Sea Water Heat Rejection



Bio-fouling Treatment by Mechanical Cleaning

Problem on conventional cleaning techniques of condenser tubes

- To take the equipment out of service
- Manual tube cleaning is labour intensive and costly
- They also incur equipment downtime
- The cleaning has to be repeated periodically

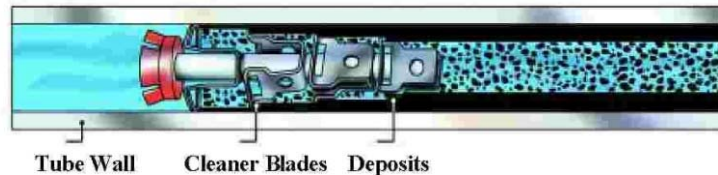

Problems and Solutions in using Sea Water Heat Rejection



Bio-fouling Treatment by Sponge Balls Method

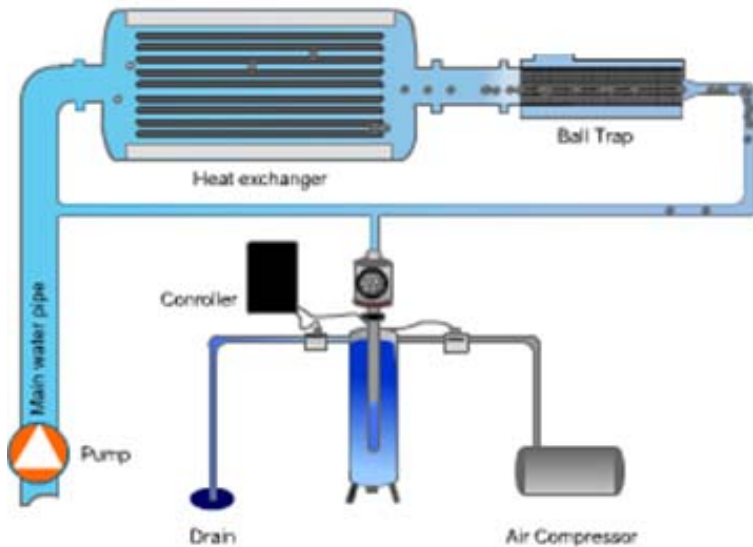

- Automatic online mechanical cleaning of condenser tubes by frequently wiping of the water side surfaces of the condenser tubes while the unit is in operation.
- Sponge balls are re-circulated constantly from the inlet to outlet water boxes.
- Since these sponge balls are slightly larger in diameter than the tubes, they are compressed and clean the surface as they travel the length of the tube.
- A collection unit would reroute them back to the condenser inlet ball injection nozzles.
- Unwanted deposits on tubes surfaces can cost up to 30% or more in energy consumption.

Problems and Solutions in using Sea Water Heat Rejection



Causes of corrosion in sea water system

- Impingement Corrosion - fairly high velocity of flow
- Impingement attack - usually localized, e.g. at inlet ends or partial obstruction
- Sand erosion
- Pitting - the effects of polluted water
- Galvanic corrosion - between tube plate and tubes
- Crevice attack underneath deposits and corrosion induced by bio-fouling countermeasures
- Failures by stress corrosion or corrosion fatigue cracking

Problems and Solutions in using Sea Water Heat Rejection



Approaches to solve

- Design and Construction Features
- Employing different preventive measures
- Selection of appropriate tube materials
- Correct operation and maintenance of plant

Problems and Solutions in using Sea Water Heat Rejection



Corrosion Control - Design and Construction Features

- Proper selection of seawater intake location
- Provision of efficient screening and filtration system
- Proper design of condenser to eliminate local turbulence
- Maintaining adequate flow can reduce the inlet impingement, attack due to deposition and foreign body partial blockage
- The fatigue failure is supporting plate normally avoided by suitable design of spacing
- Stress corrosion cracking by reducing residual stresses at the rolled-in portion of tube through special heat treatment.



Corrosion Control - Employing different preventive measures

- Nylon inserts for protection of the inlet tube ends.
- Addition of ferrous ions by dosing ferrous sulphate or iron corrosion products. This promote the formation of protective firm on the condenser tubes and reduce the harmful effect of any residual chlorine (as low as 0.2 ppm may be very harmful).
- Provision of cathodic protection to the tube inlets, the tube plates and water boxes using sacrificial zinc or iron.
- High molecular weight inhibitor for pre-treating tubes for protecting tube surface.
- Application of artificial protective films on the tube surface.



Problems and Solutions in using Sea Water Heat Rejection

High first cost and maintenance cost on sea water equipment

Condensers- *Shell and Tube Type*

Shell	Tubes
<ul style="list-style-type: none">➤ Cast iron➤ Mild steel with epoxy coating.➤ gunmetal (more expensive)➤ silicon bronze (more expensive)➤ aluminium bronze (more expensive)➤ nickel alloys (more expensive)	<ul style="list-style-type: none">➤ 70/30 or 90/10 cupro-nickel (more resistant to impingement attack and polluted waters)➤ Aluminium brass (preferred if relatively higher working temperatures are involved)➤ Bronze➤ Stainless Steel(suffers crevice and stress corrosion attacks)➤ Titanium (very high corrosion resistance, high cost)



Problems and Solutions in using Sea Water Heat Rejection

High first cost and maintenance cost on sea water equipment

Piping

- Cast iron pipe with concrete lining (most common in Hong Kong)
- Concrete Pipe



Valves

- Cast Iron
- Bronze
- Stainless Steel (not common in Hong Kong)





Problems and Solutions in using Sea Water Heat Rejection

High first cost and maintenance cost on sea water equipment

Plate Type Heat Exchanger

Titanium is adopted.

The Plant type heat exchanger cools fresh water which in turn is passed to a second stage shell-and-tube type condenser where the refrigerant is cooled.

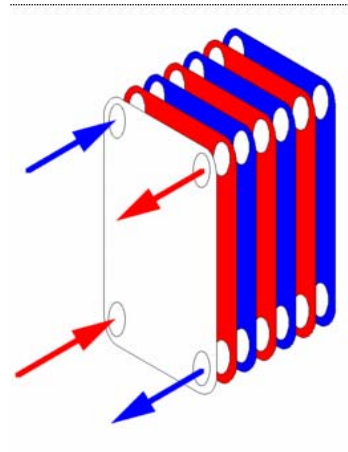
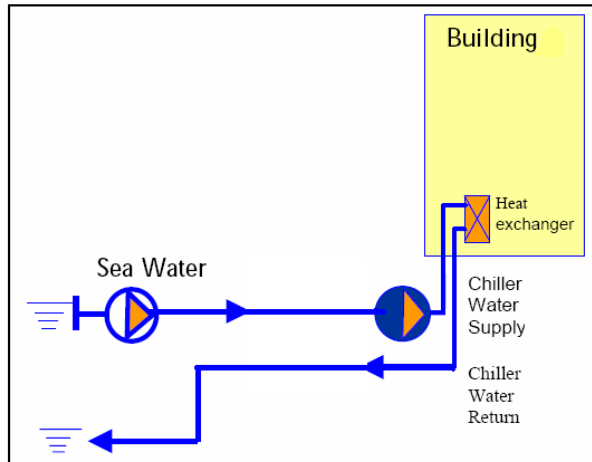

Problems and Solutions in using Sea Water Heat Rejection



High first cost and maintenance cost on sea water equipment

Pumps (Centrifugal)

- Casings - Cast Iron or Copper-based alloys
- Impellers - Zine-free Bronze, Stainless Steel or Cupro-nickel
- Strainers - Cast Iron Casing with Stainless Steel or Bronze filtering elements





Substantial Amount of Maintenance Works

- Rapid blockage of primary screens and strainers by floating or semi-floating objects (especially plastics bags) and various marine foulants (may be up to three to four times a day during the summer).
- Other frequently found problems are corrosion of screens and filtration elements of strainers along welded lines.
- Corrosion of seawater valves, erosion & corrosion of pump impellers and inlet attack of condenser tubes.
- Since high frequency of cleaning and maintenance are needed for some of the components in the circuits, employment of operators are preferred as technical skill is essential for smooth operation of the systems.
- Stand-by components such as screens, pumps, strainers and condensers are commonly adopted.



Substantial Amount of Maintenance Works

- Maintenance works and frequency depend on the types of preventive measures and equipment used, sea water quality and etc.
- Experienced personnel in plants can determine suitable times for maintenance by observation of equipment performance.
- Abnormal increase in pressure drop across condenser inlets and outlets, strainers and screens may indicate extensive fouling or blockage in condensers and cleaning may be necessary.
- Cleaning or maintenance regularly in order to maintain continuous good efficiency.
- Anti-foulant is often dosed after accumulation of marine foulants taken place at the well exposed meshes.

Centralised Piped Supply System for Condenser Cooling (CPSSCC)

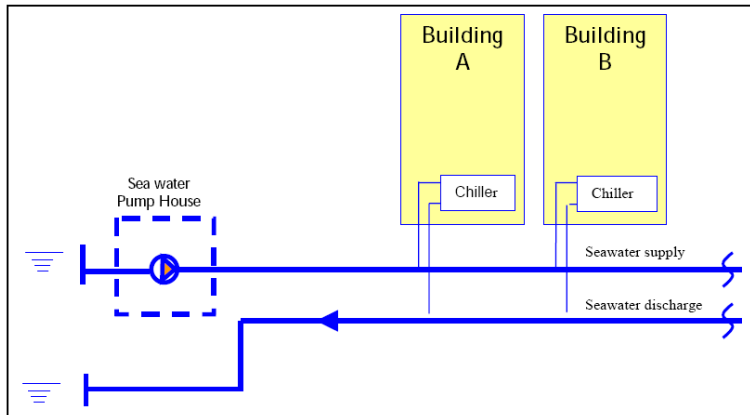

For a building served by CPSSCC, its air conditioning systems uses seawater for heat rejection of the chiller condenser, either directly or indirectly through a heat exchanger.

A dedicated central seawater supply system will distribute seawater from the seawater pump house to the user buildings through a common supply pipe.

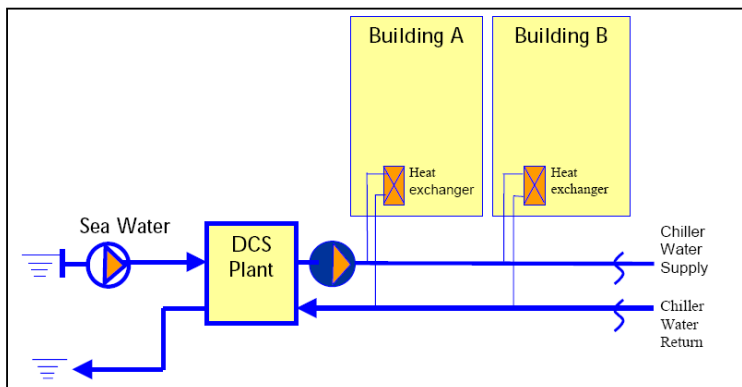

The rejected warm seawater from the chiller condensers will be discharged to the sea through another common discharge pipe.

Centralised Piped Supply System for Condenser Cooling (CPSSCC)



CPSSCC for government buildings

The Central Reclamation Phase III (CRIII) Project is the final phase of planned waterfront reclamation in the Central District of Hong Kong Island.

The reclamation affected the cooling water pumping stations for a large number of existing private and government buildings.

There a need to relocate the seawater pump houses to the shore and a CPSSCC is implemented for the affected government buildings.

The total chiller plant capacity that could be served by this pumping station is about 20,000 TR.

As in early 2007, the centralized government pumping station is under testing and commissioning.

Centralised Piped Supply System for Condenser Cooling (CPSSCC)



CPSSCC for private development

A private developer has submitted a town planning application for utilising the existing seawater pump house to serve a number of buildings.

The application was approved by the Town Planning Board in August 2006.

The proposal is to build a seawater pump house with seven pumps to serve a group of buildings owned by the private developer.

The planned total chiller capacity to be served by the pump house ultimately is 15,000 TR.

This seawater pump house will be a showcase of the use of CPSSCC in the private sector.



Question and Answer