

MEBS6008 Environmental Services II

<http://www.mech.hku.hk/bse/MEBS6008/>

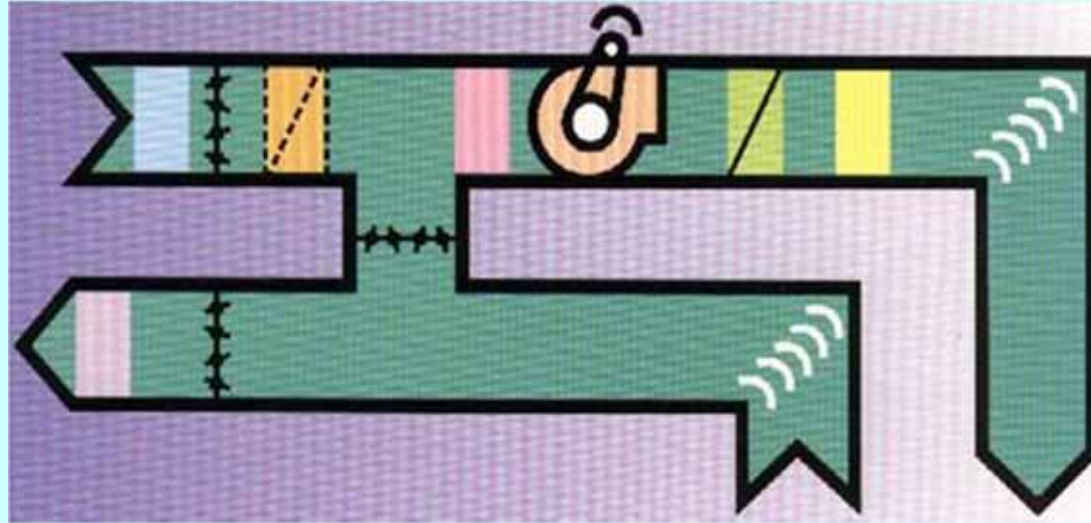

Space Air Diffusion II



Dr. Sam C. M. Hui

Department of Mechanical Engineering
The University of Hong Kong

E-mail: cmhui@hku.hk

Sep 2012

Contents



- Cold Air Distribution
- Displacement Flow
- Underfloor Air Distribution
- Unidirectional Flow
- Projecting Flow
- Air Flow Analysis

Cold Air Distribution



- Lower supply air temp. = 4.4 to 7.2 °C
- Conventional air distribution = 12.7 to 15.0 °C
- Applied mainly in conjunction with ice storage systems
 - Lower chw temp. (1.1 to 2.2 °C) (from ice storage)
- Main advantages:
 - Reduce design supply volume flow (larger ΔT)
 - Air-side components can be downsized
 - Fan energy use can be reduced
 - Reduced fan sound levels
- Drawbacks: dumping of cold air jet & IAQ issues

Cold Air Distribution



- Design considerations
 - Condensation
 - Cooled surfaces shall be well insulated & sealed
 - Comfort
 - Air supplied at lower velocities: diffuser performance is affected (e.g. dumping & stagnant at low load)
 - Indoor air quality
 - Minimum ventilation flow is required; may need reheat
 - Controls
 - Start-up & shut-down, humidity controls, VAV, etc.

Cold Air Distribution



- Two methods for cold air space diffusion
 - High induction nozzle diffusers
 - Direct from AHU or package unit
 - Fan-powered VAV boxes
 - Mix low-temperature supply air with return air before supplied to the conditioned space
- Characteristics of cold air distribution
 - Higher \sqrt{Ar} / Do value
 - Higher supply air velocity & jet turbulence
 - Good surface effect (adequate throw, small drop)
 - ADPI ≥ 80 at both design & reduced airflow

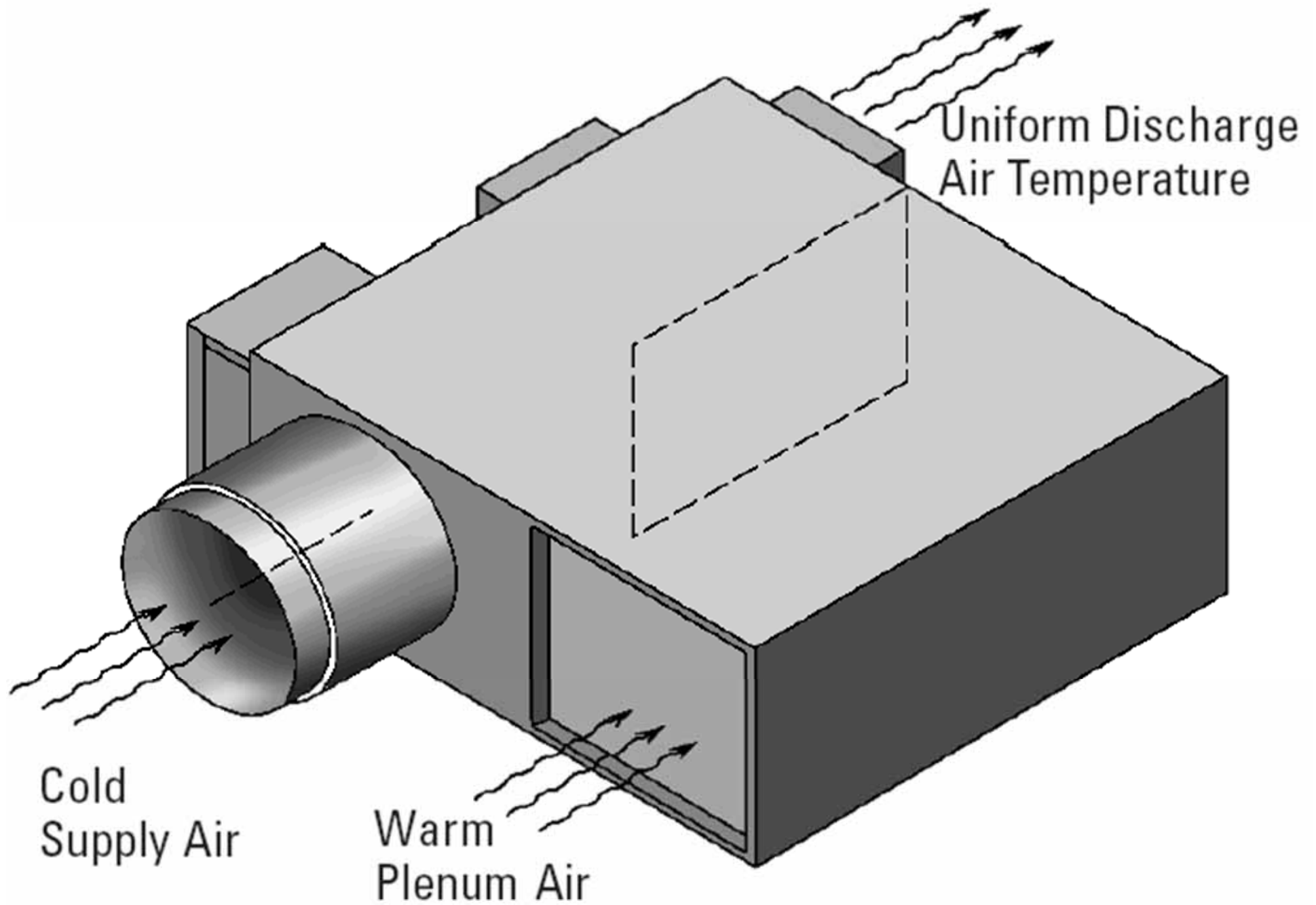

Series flow fan power terminal

(Source: <http://www.price-hvac.com>)

Cold Air Distribution



- Design checks
 - Performance of ceiling & slot diffusers
 - Any difference compared with conventional system?
 - Fan-powered VAV boxes
 - In parallel or in series
 - Mixing w/ return air to get suitable supply temp.
 - Provide space air movement
 - Higher noise & more maintenance
 - Surface condensation
 - Sufficient thermal insulation is needed to prevent this

Displacement Flow



- Displacement flow
 - Cold supply air at a velocity nearly equal to the required velocity and displace the original air with piston-like airflow w/o mixing
 - If properly designed, it can give:
 - Better IAQ in occupied zone
 - Higher space diffusion effectiveness
 - Low turbulence intensities & fewer draft problems
 - Drawbacks:
 - Require greater supply volume flow rate
 - Higher construction cost



Displacement ventilation (DV)



Mixing ventilation (MV)

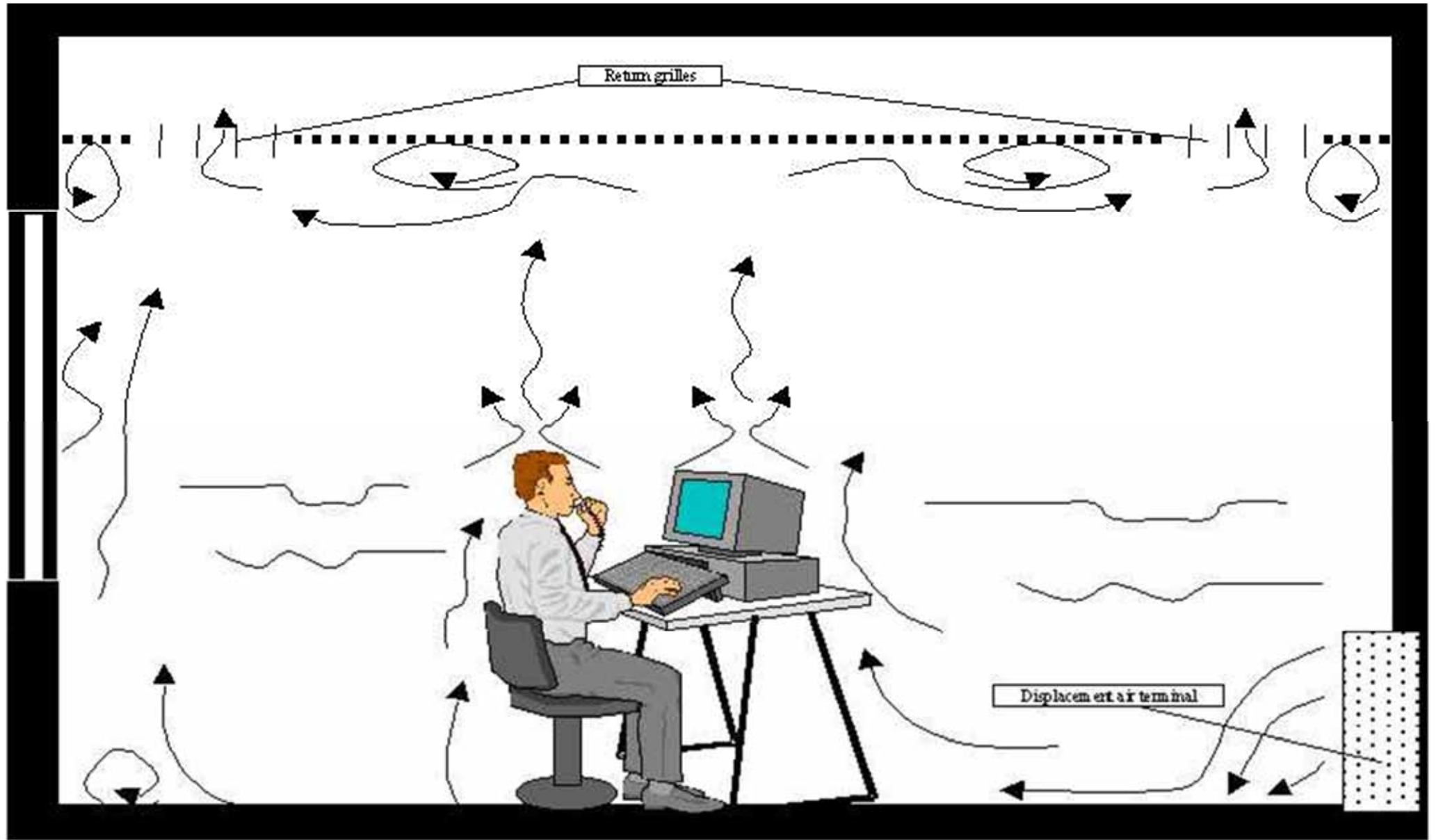

Typical displacement ventilation room layout

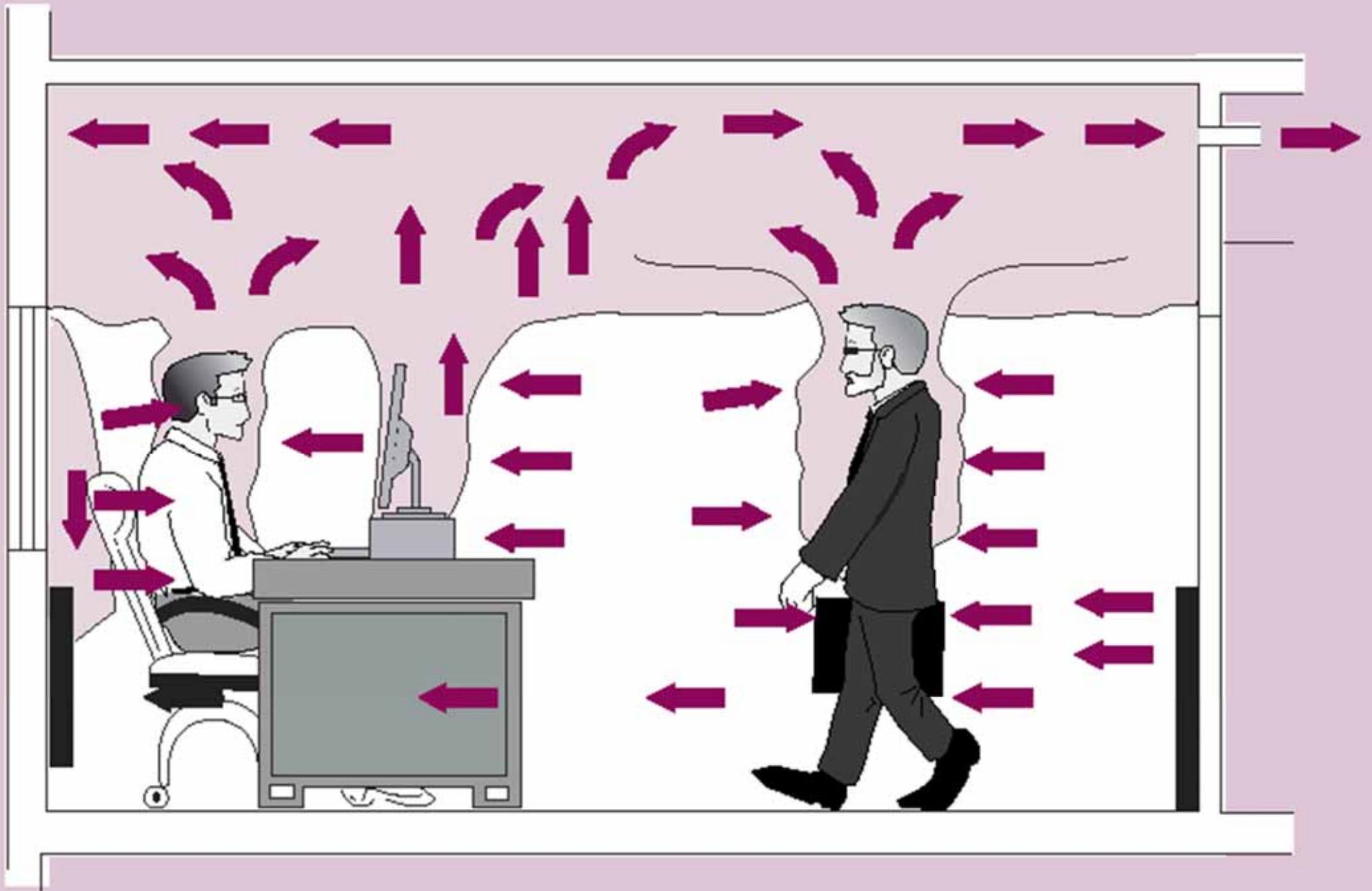

Displacement flow characteristics

(Source: <http://www.price-hvac.com>)

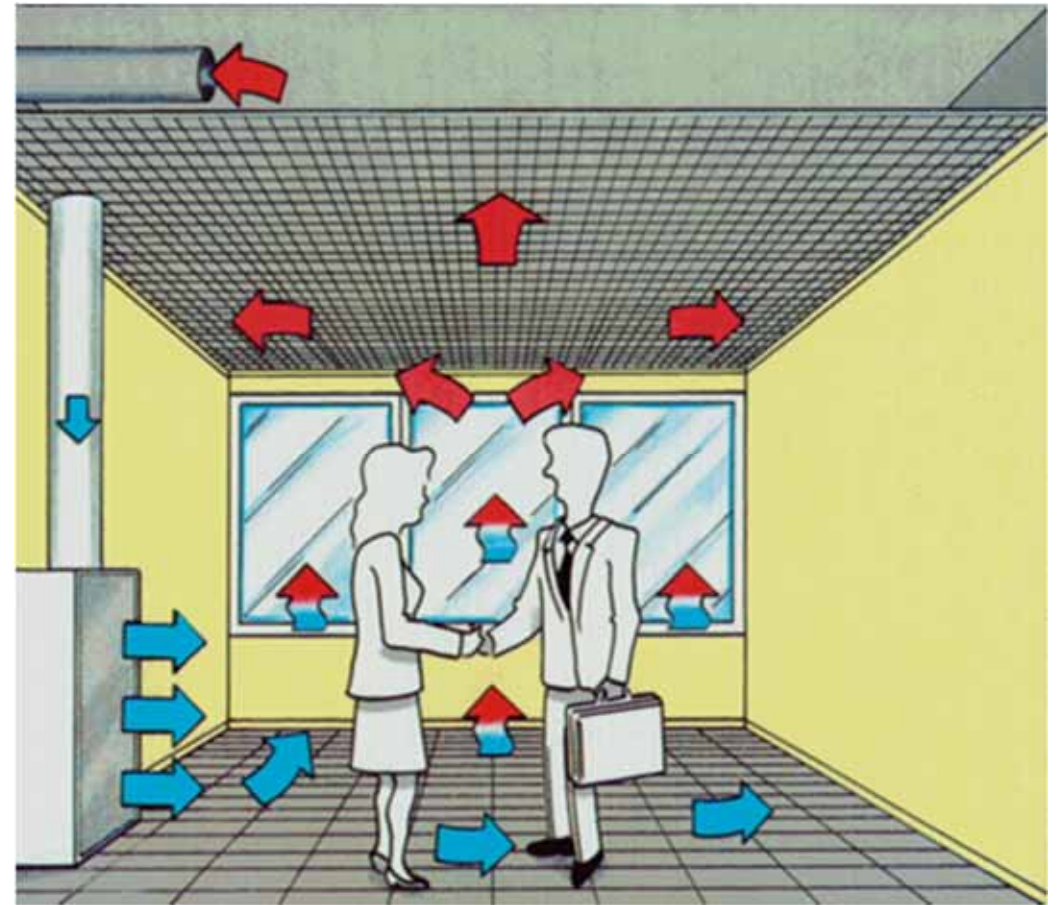
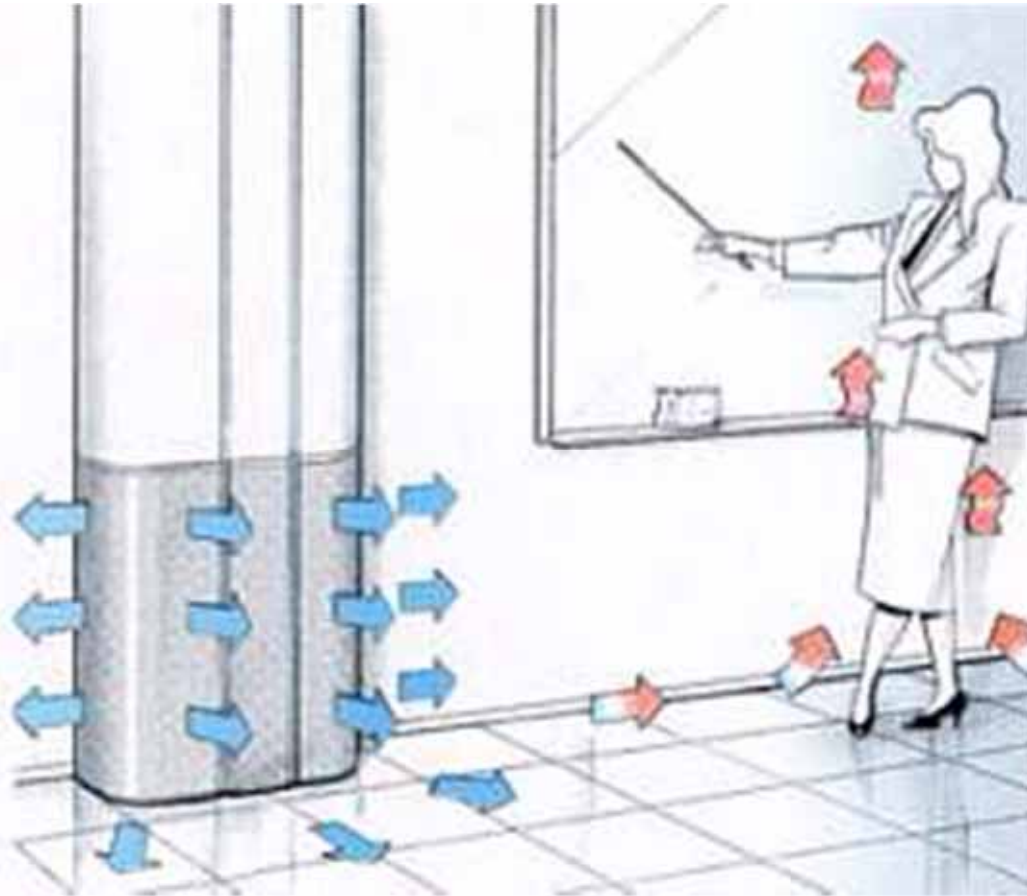

Displacement ventilation system

Displacement Flow



- Airflow patterns
 - Because of low discharge velocity, air motion is influenced to a large degree by convection flows
 - Convection flows (or thermal plumes) are created by heat sources, e.g. people, equipment, warm windows
 - Cold sinks (e.g. cold windows) may create flows down
- Airflow penetration
 - Supply air spread across the floor in a thin layer, filling the entire space
 - Flow around & beyond obstructions

Figure 5 - Horizontal Air Movement

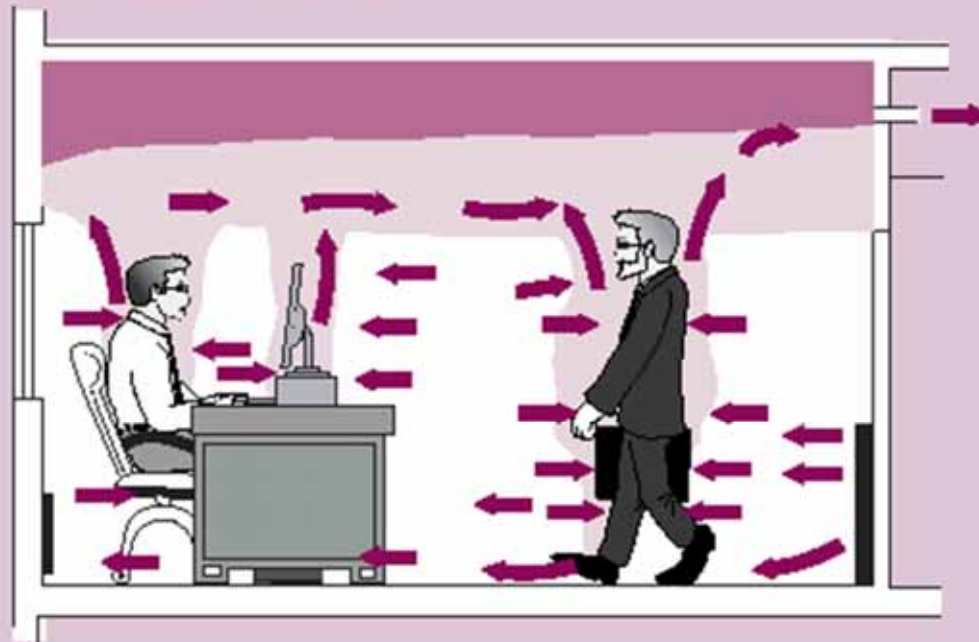
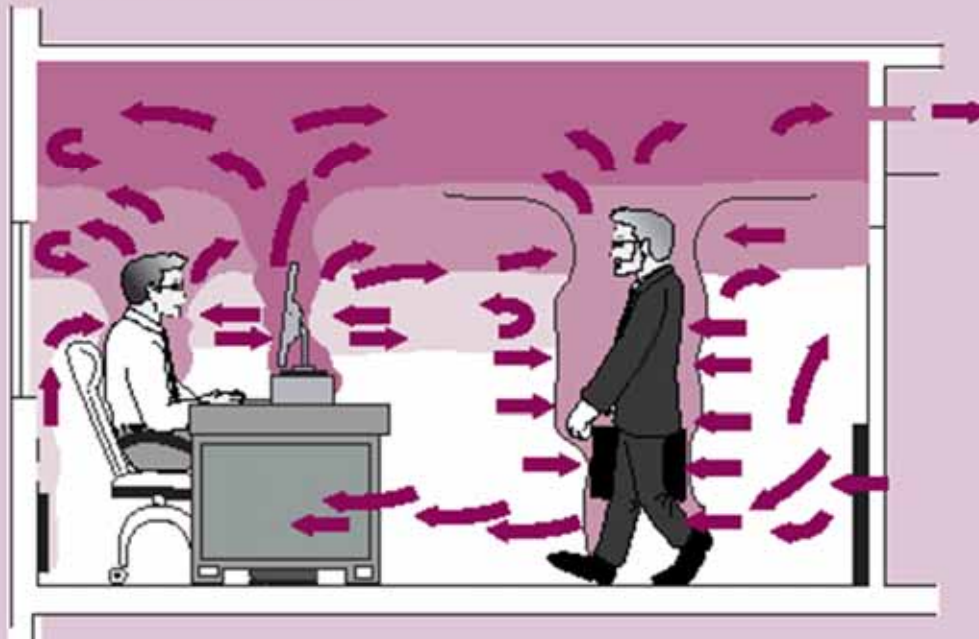

Figure 6 - Vertical Air Movement



Displacement flow patterns

(Source: <http://www.price-hvac.com>)

Figure 7 - Obstruction

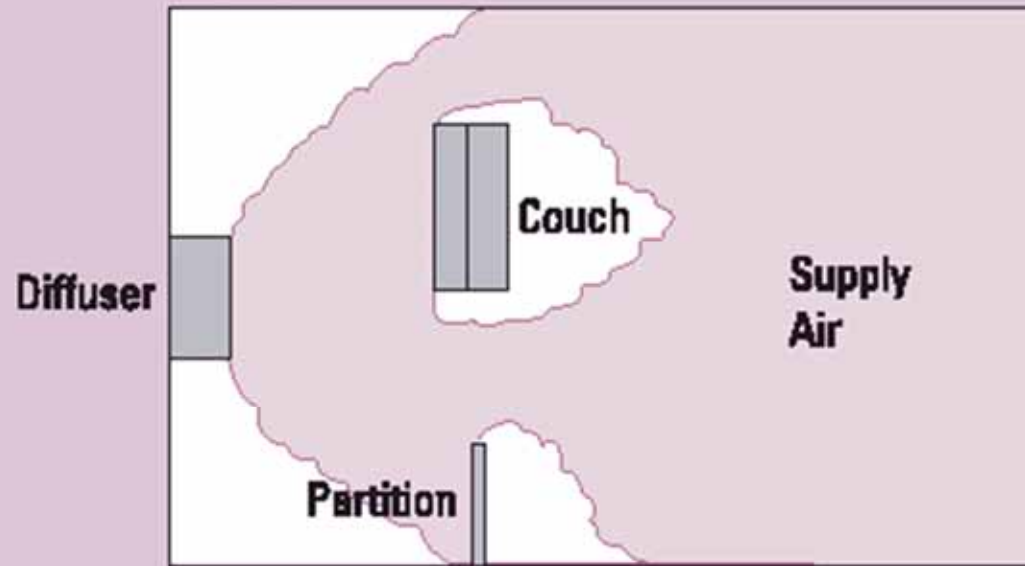
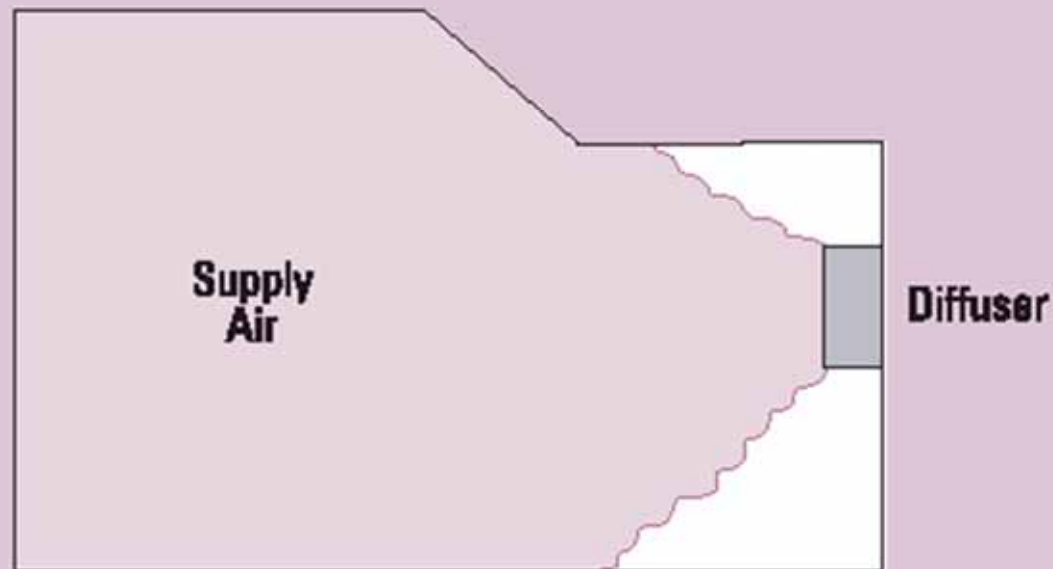

Figure 8 - Irregular Room Geometry



Airflow penetration

(Source: <http://www.price-hvac.com>)

Displacement Flow



- Diffuser airflow patterns
 - To avoid draft, displacement diffuser shall deliver the supply air uniformly at low velocity
 - With internal equalization baffle & low free area face
 - For cool air supply, it will fall towards the floor
 - For isothermal air, it will distribute horizontally
 - For heated air, the discharge air will rise
 - Therefore, it is not recommended to supply heated air

Figure 9 - Cool Air Supply

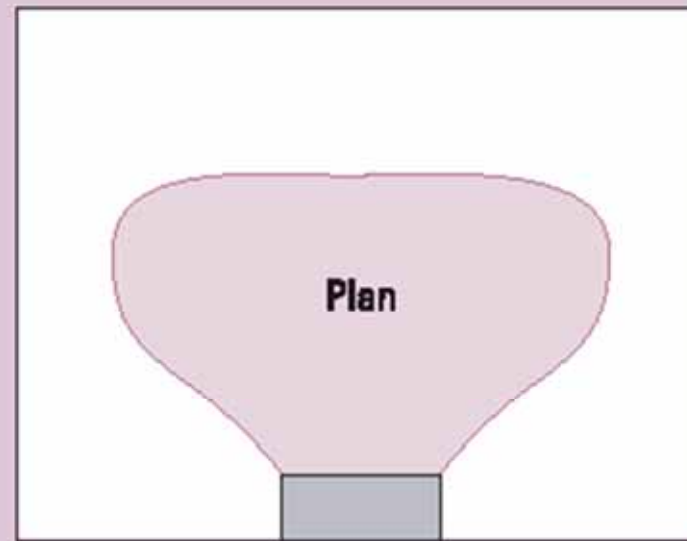
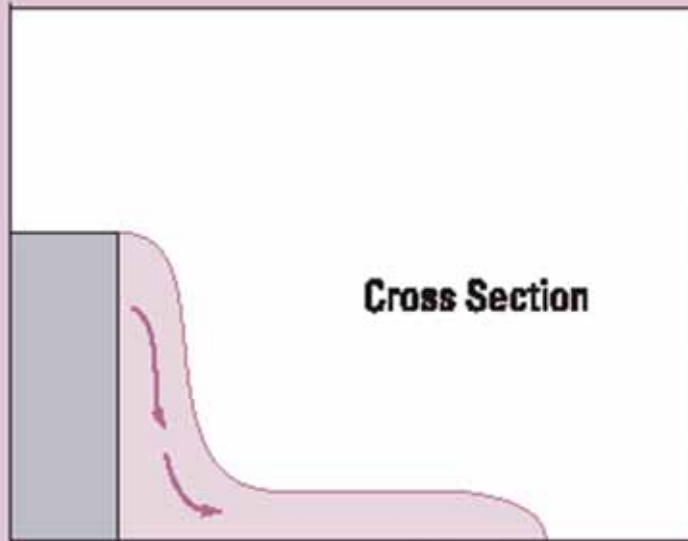

Figure 10 - Isothermal Air Supply

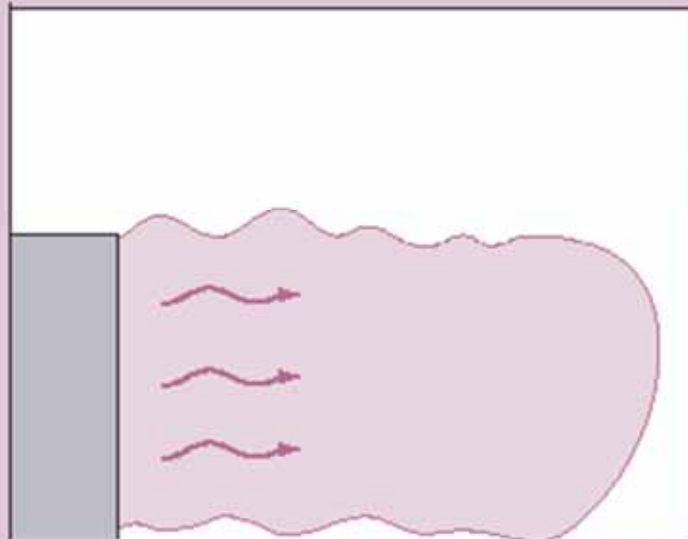
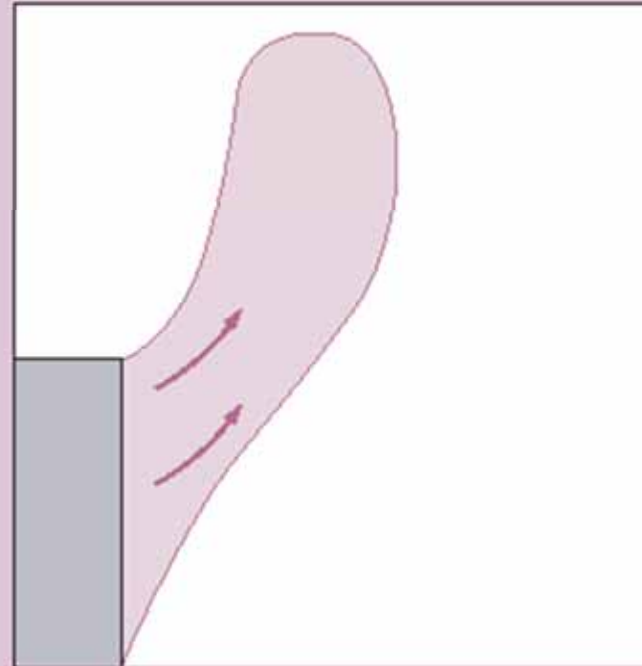

Figure 11 - Heating Air Supply



Displacement diffuser airflow pattern

(Source: <http://www.price-hvac.com>)

Displacement Flow



- Contaminant distribution
 - Can reduce contaminant in lower portion of room
 - Actual distribution is influenced by factors e.g. contaminant source type & location, human body convection and space height, strength of thermal plume
- Ventilation effectiveness
 - Displacement can achieve around 1.2-1.4; most mixing systems is around 1.0

Figure 12 - Contaminant Distribution

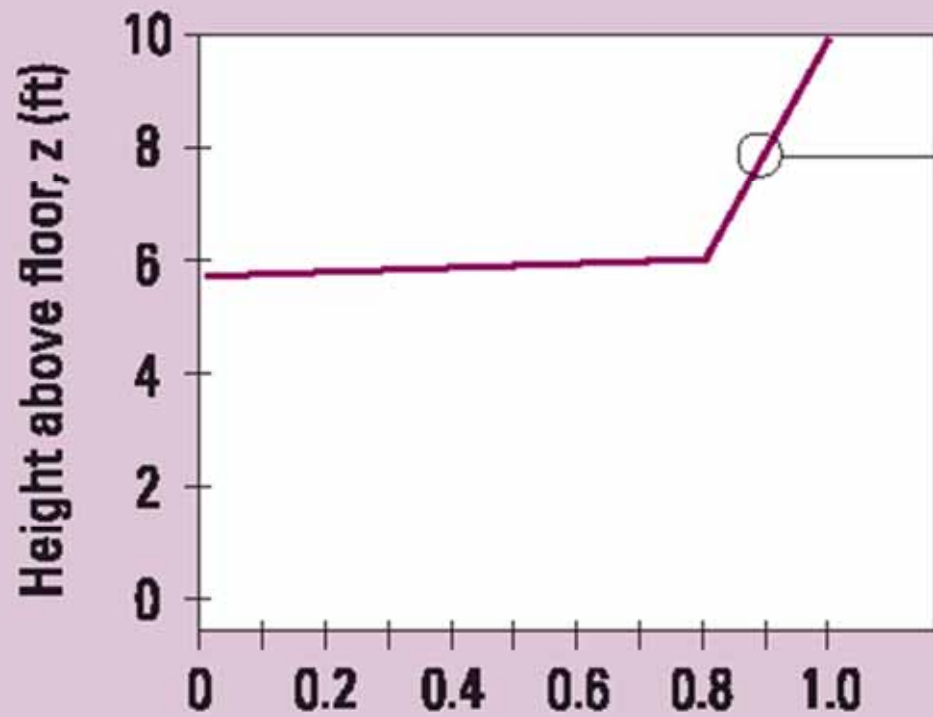

Contamination ratio, $C_{room} / C_{exhaust}$

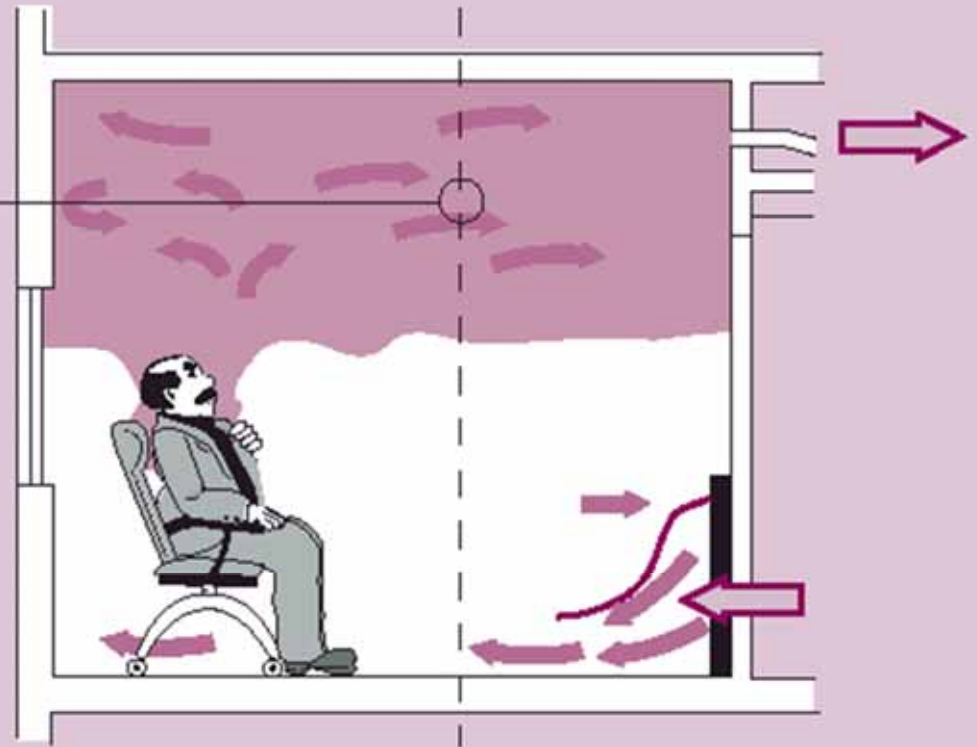

Ref: REHVA Guidebook

Displacement Flow



- Temperature distribution
 - Temperature gradient between the floor & ceiling
 - Also known as “Stratification”
 - Affected by factors e.g. supply air volume, room cooling load, location & type of heat source, height of the space
 - Controlling stratification is critical to maintain thermal comfort
- If heating is needed, may use radiator to offset cold downdrafts near the windows

Figure 13 - Vertical Temperature Gradient

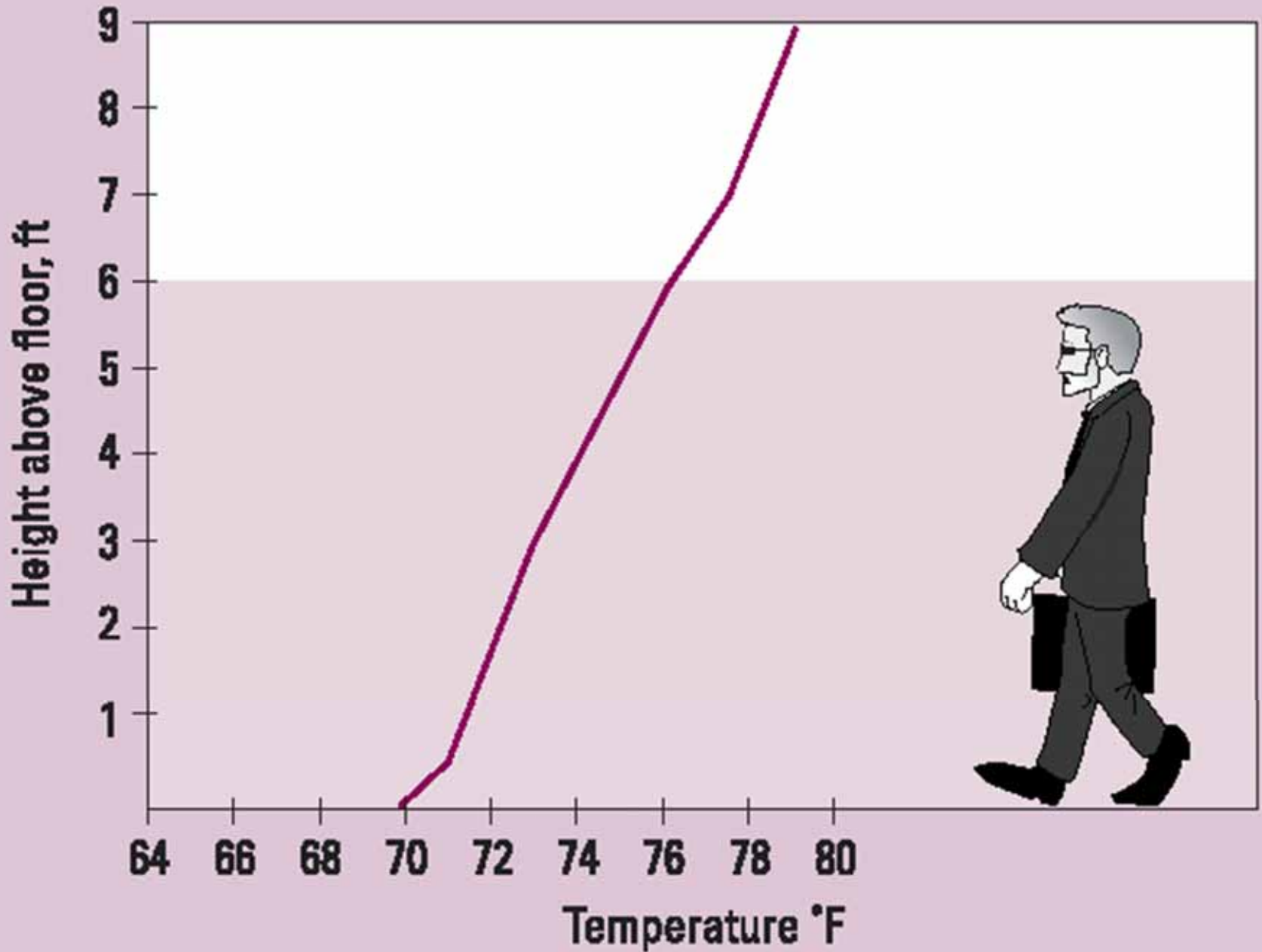

Displacement ventilation – temperature gradient

(Source: <http://www.price-hvac.com>)

Figure 14 - Heat Source Location

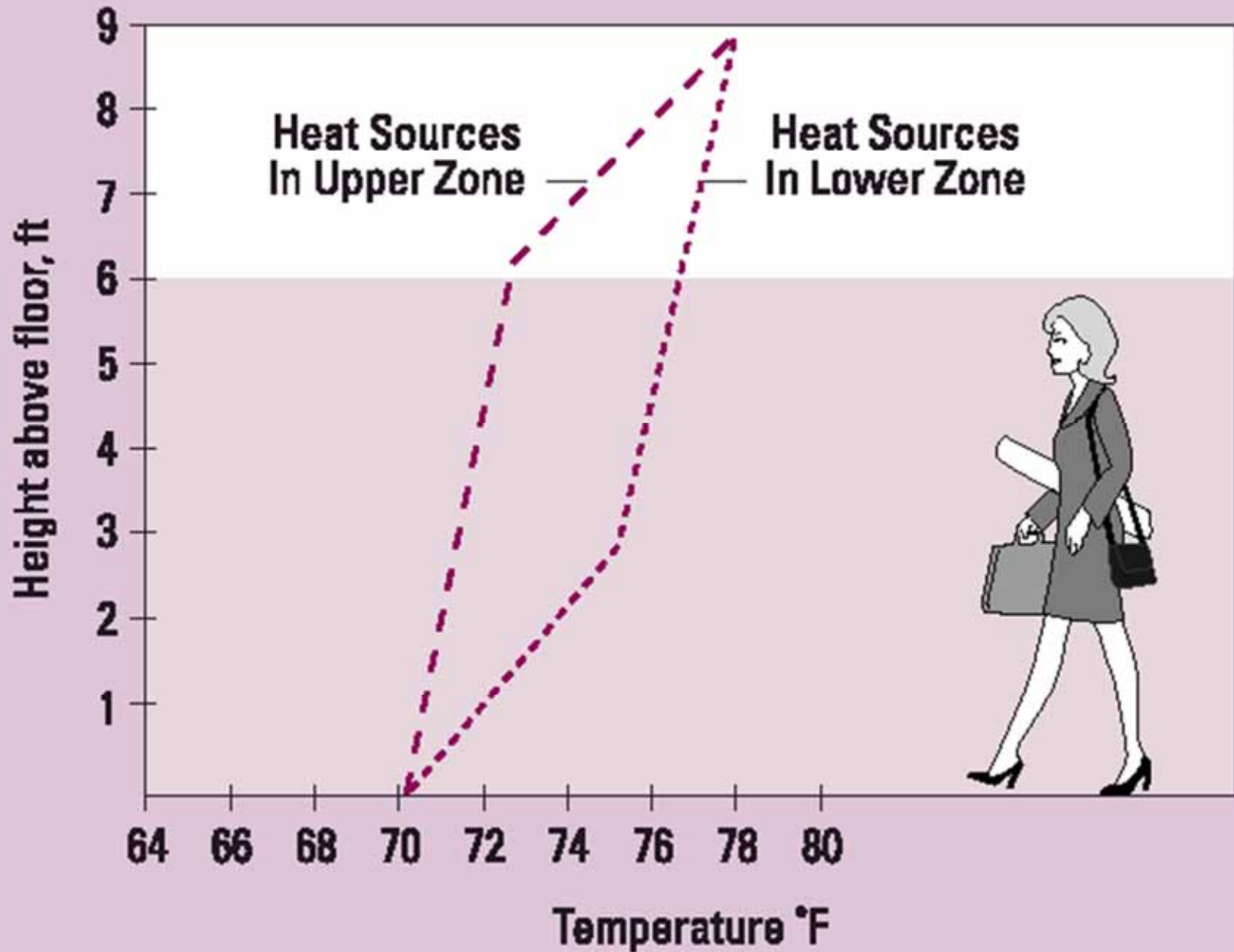

Displacement ventilation – temperature gradient

(Source: <http://www.price-hvac.com>)

Figure 15 - Baseboard Radiation

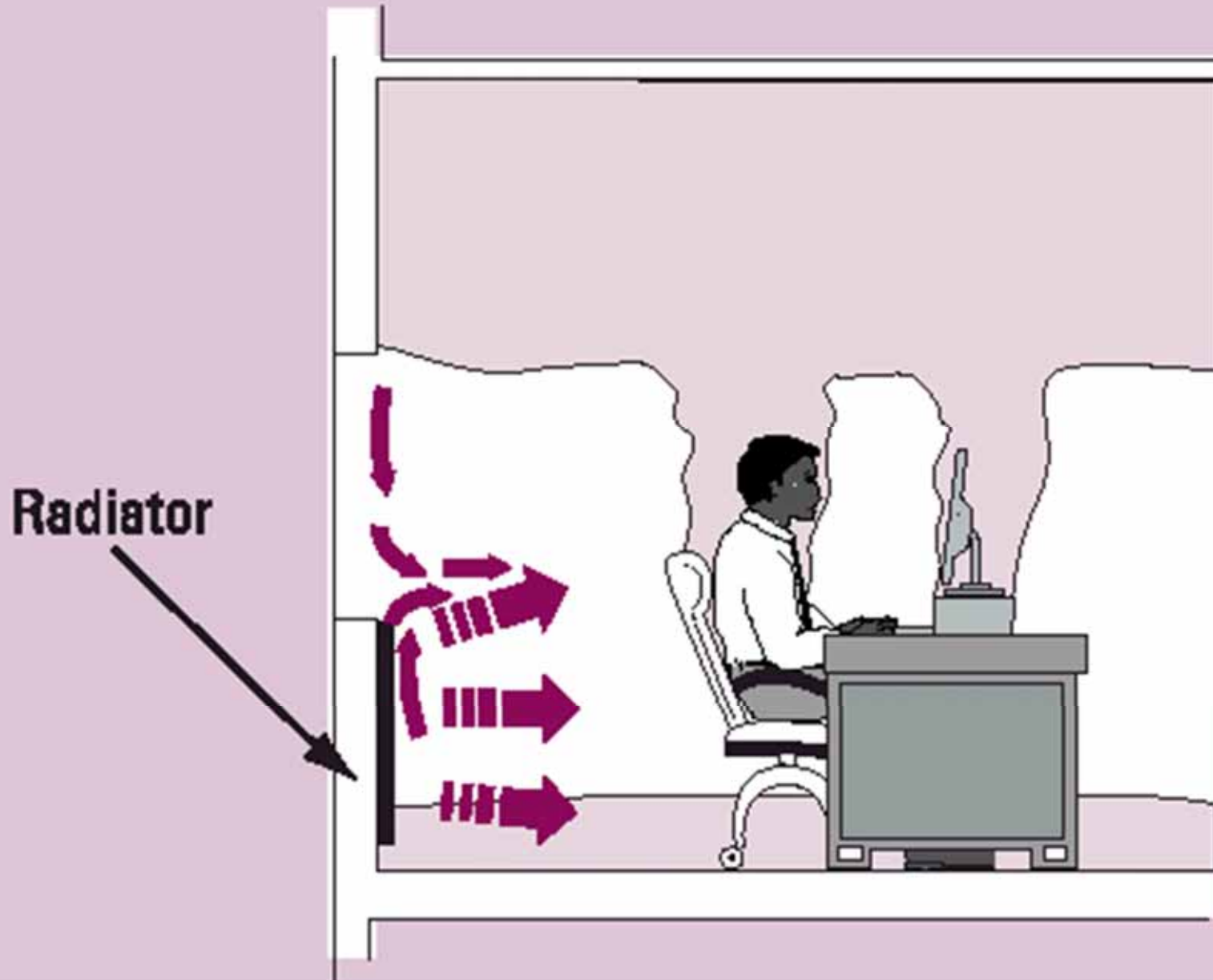

Displacement ventilation and radiator

(Source: <http://www.price-hvac.com>)

Displacement Flow



- Stratified displacement flow
 - First introduced in Scandinavian countries
 - Low-level supply outlet
 - Above heat & contaminated sources
 - Heated air rises upward due to buoyancy effect
 - Supply air is entrained into the upward convective flow
 - Stationary level: upward flow = supply flow
 - Two-zone stratified model: upper zone & lower zone

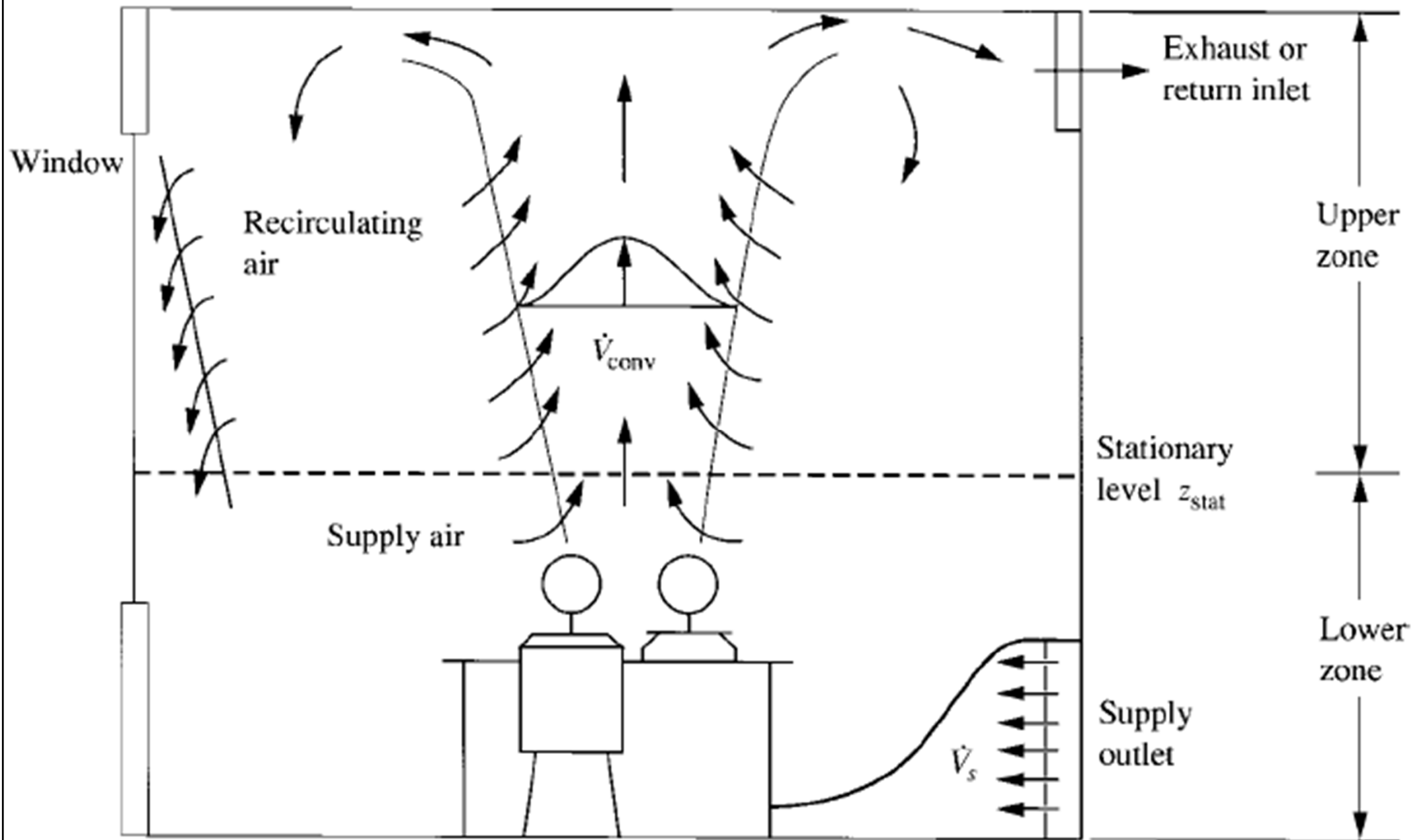

Stratified displacement flow in a typical room

Displacement Flow



- Characteristics of stratified displacement flow
 - Cold air supply of usually 100% outdoor air
 - Air must be supplied at low velocity (< 0.3 m/s) & at a height less than 0.54 m above floor
 - Cold air supplied at 2.8 to 5 °C lower than occupied zone
 - Height of lower zone shall be higher than a seated occupant (1.4 m); all air is supply air in lower zone
 - Smaller cooling load density (max. 41 W/m²)
 - Return or exhaust inlets located near ceiling level

Displacement Flow



- Design procedure
 - Step 1: determine summer cooling load
 - Occupants, lights, equipment, envelope
 - Step 2: determine cooling load ventiln. flow rate
 - Equation from the ASHRAE design guide
 - Step 3: determine flow rate of fresh air
 - Step 4: determine supply air flow rate
 - Max {Step 2, Step 3} flow rates
 - Step 5: determine supply air temperature
 - Step 6: determine exhaust air temperature

Displacement Flow



- Common diffuser types
 - Rectangular units
 - Corner units
 - Semi-circular units
 - Circular units
 - Floor mounted units



Underfloor Air Distribution



- Upward flow underfloor air distribution
 - Conditioned air from floor plenum (0.3-0.45 m)
 - Usually ductless (air duct has also been used in the past)
 - Supply outlets
 - Floor diffusers, fan-driven units, desktop units, supply outlets from fan coil units and water-source heat pumps
 - Often partial displacement & partial mixing
 - Cool primary air from AHU
 - Applications of underfloor air distribution
 - Computer rooms air conditioning
 - Commercial buildings (w/ access raised floor systems)

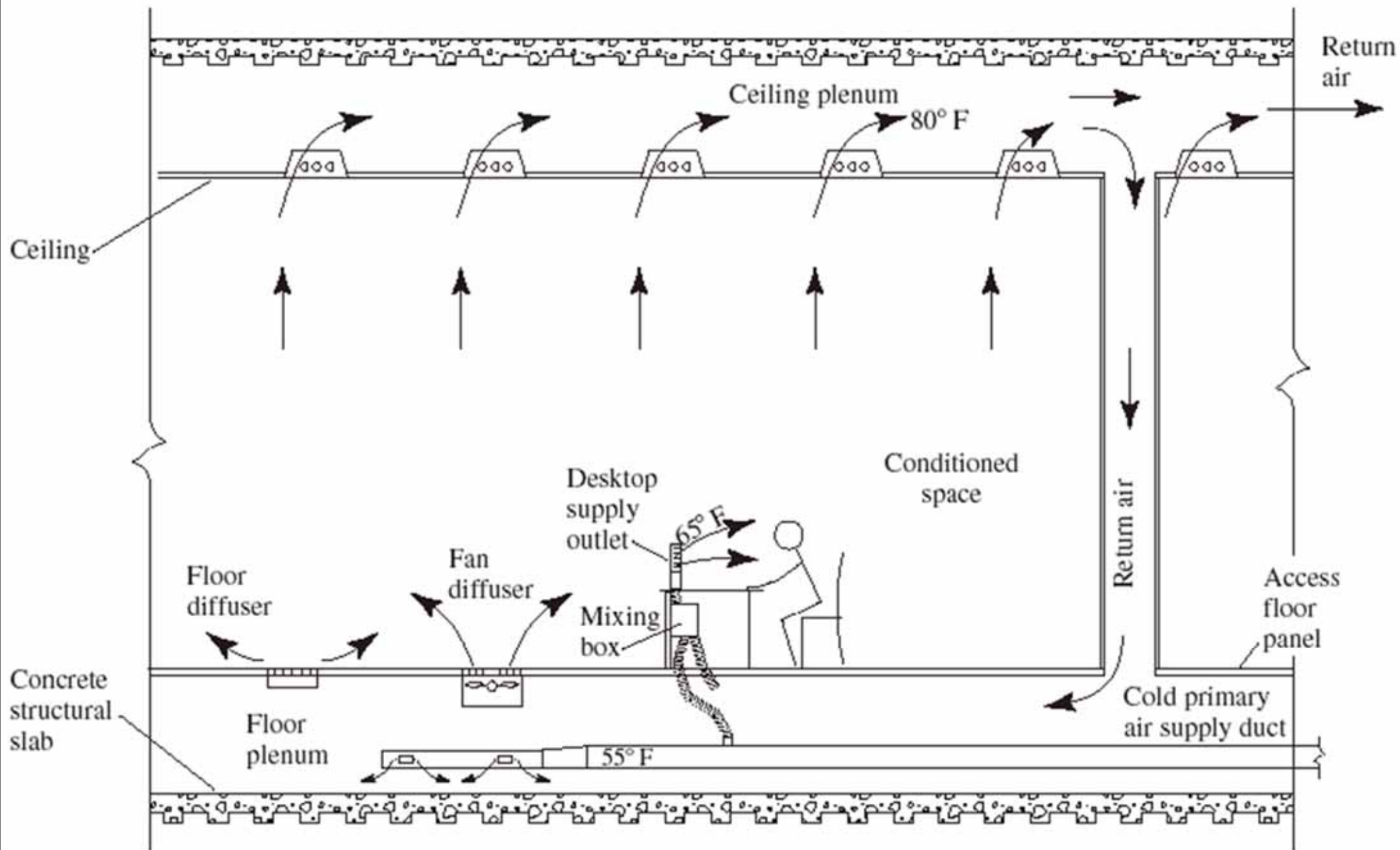

Upward flow underfloor air distribution system

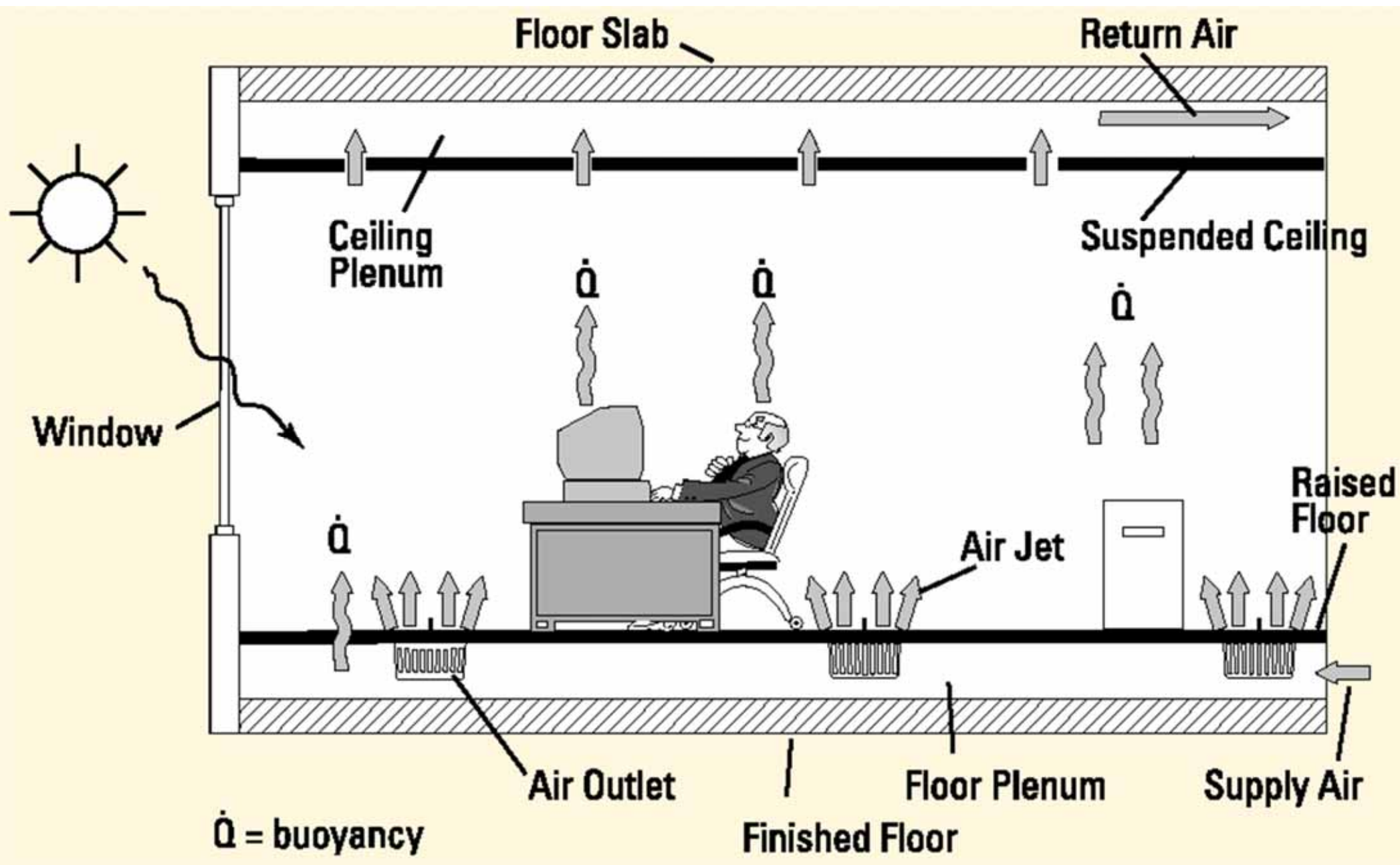

Underfloor air supply

(Source: <http://www.price-hvac.com>)

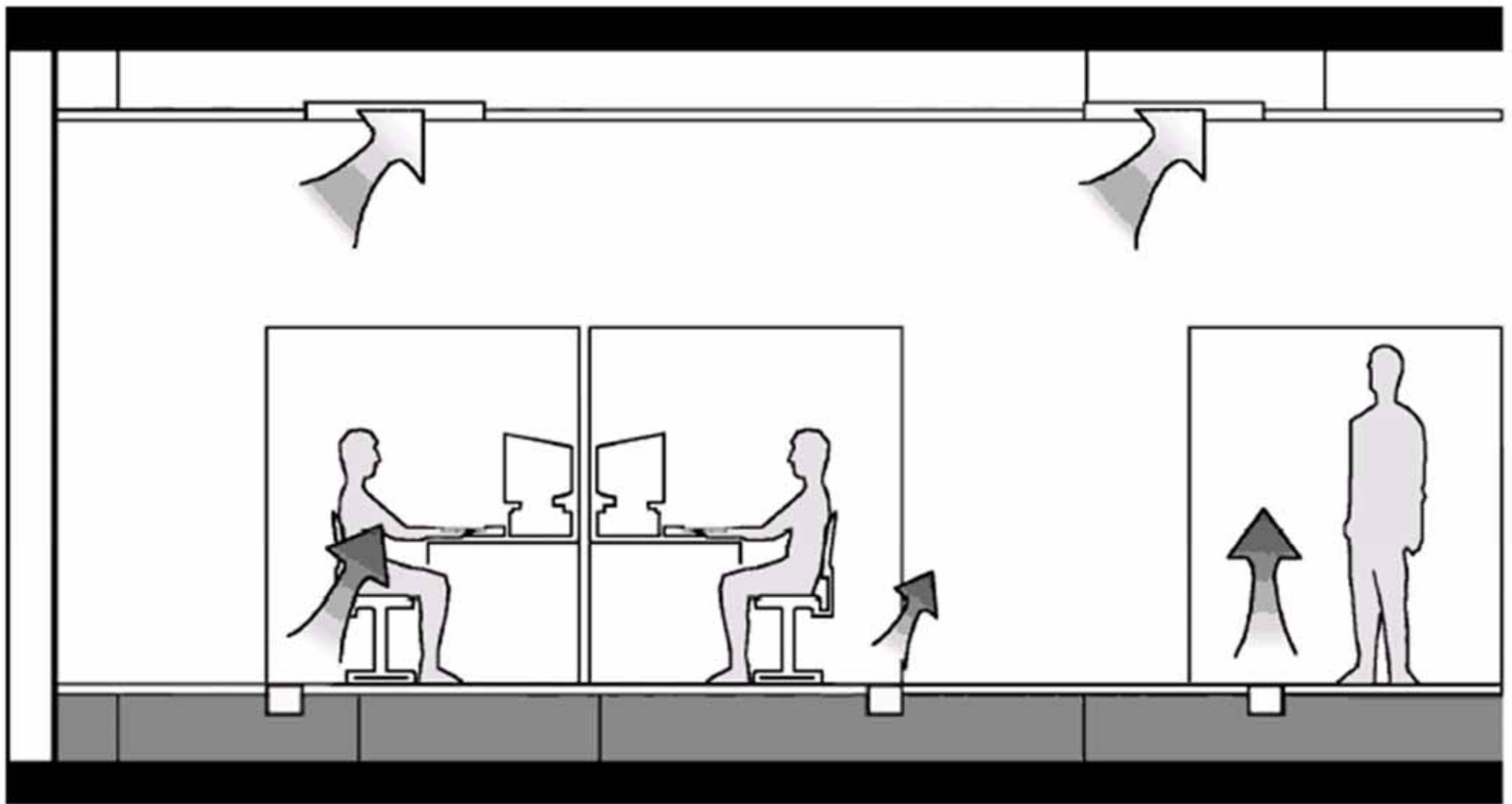

Underfloor air distribution system

(Source: *ASHRAE Underfloor Air Distribution Design Guide*)

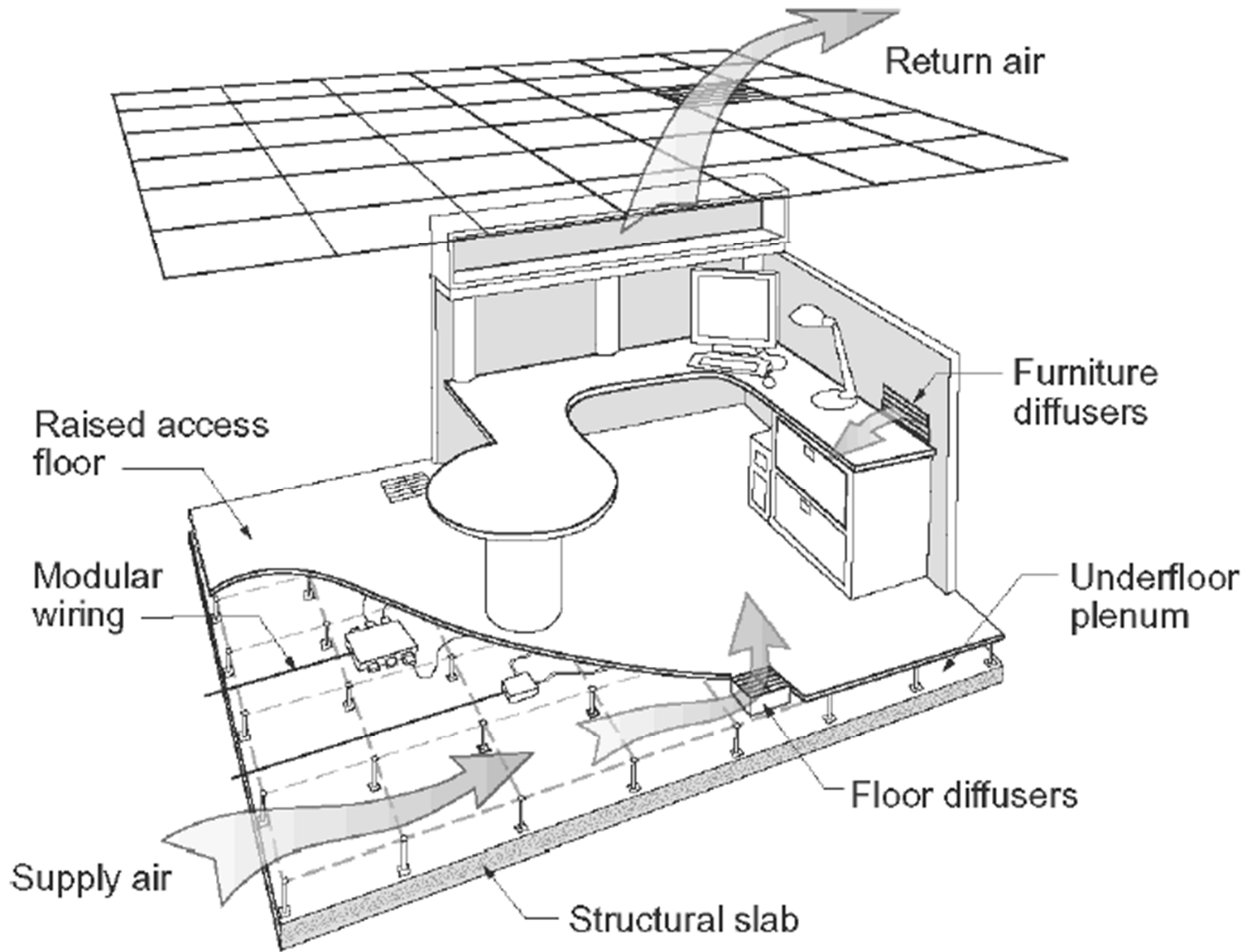

Office space with underfloor air distribution & task air-conditioning

(Source: *ASHRAE Underfloor Air Distribution Design Guide*)

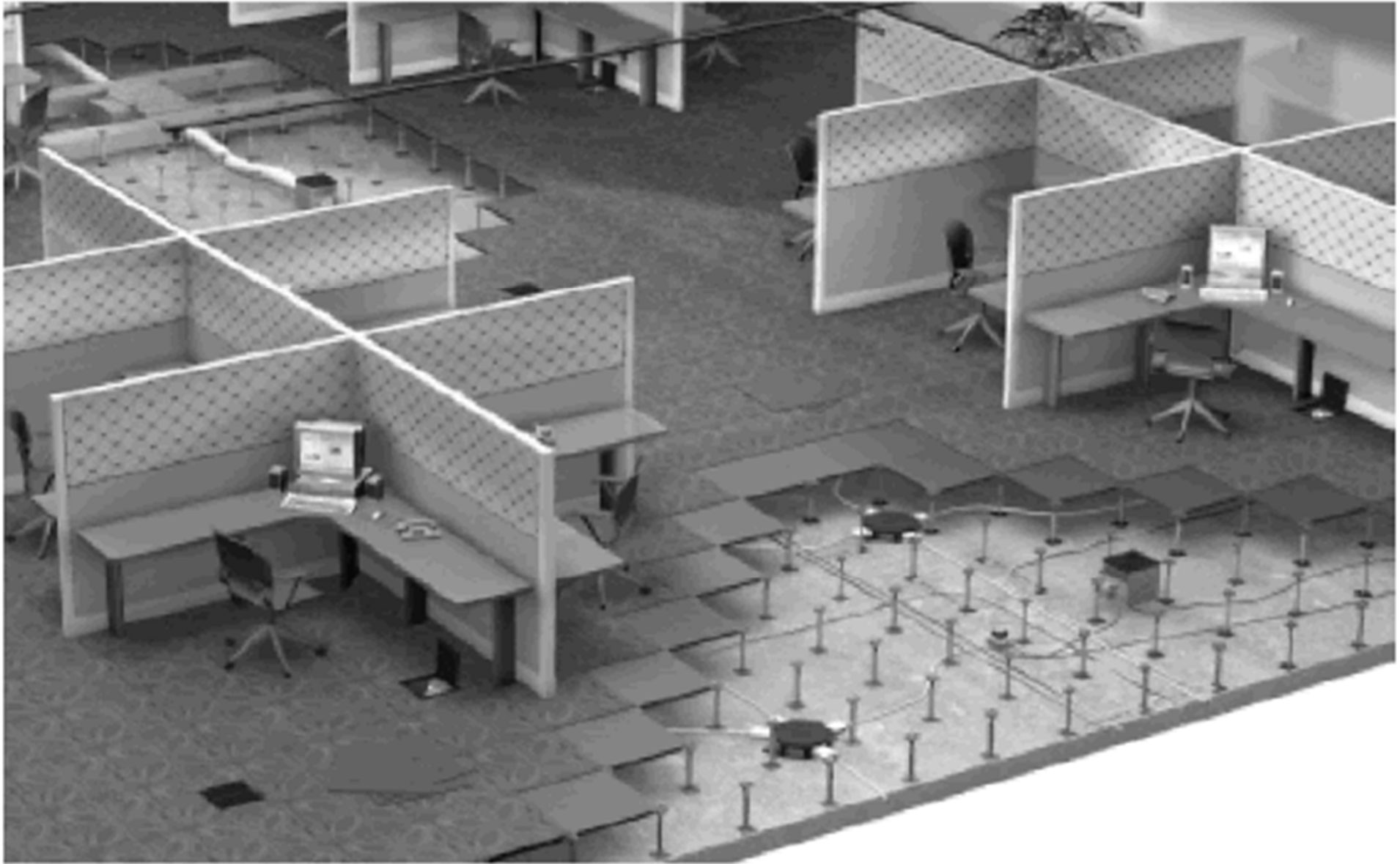

Installation of raised floor system in open plan office

(Source: *ASHRAE Underfloor Air Distribution Design Guide*)

Underfloor Air Distribution



- Design factors of underfloor air distribution
 - Thermal storage of floor plenum
 - Primary air in direct contact with concrete floor slab
 - Heat unneutralised
 - Upward air flow lifts the heat unneutralised to ceiling
 - Greater capability to capture/exhaust heat thru' ceiling
 - Maintaining a consistent access plenum temp.
 - Blending air for suitable temperature; travel distance
 - Master zone air temp. control
 - Important for VAV system to response to load changes

Underfloor Air Distribution



- Advantages of underfloor air distribution
 - Integrated well with raised floor plenum
 - Can be very flexible for future changes/relocations
 - Conditioned air is supplied directly to occupants
 - Stagnant air can be reduced (if ceiling return)
 - Upward flow lifts some unneutralised heat
 - It can utilise thermal mass of access floor & slab to reduce peak demands
- Disadvantages
 - Higher initial costs
 - Need for raised floor system & floor diffusers

Overhead VAV Distribution

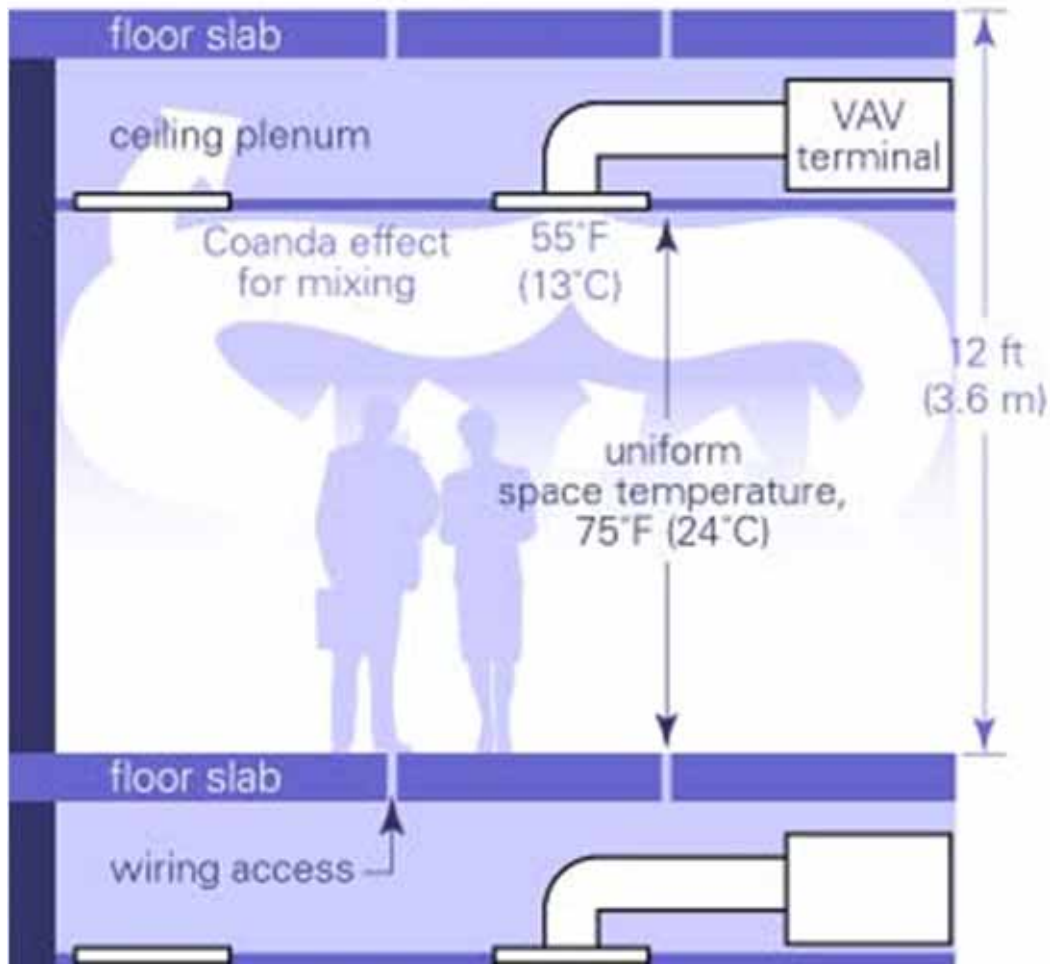

Displacement Ventilation

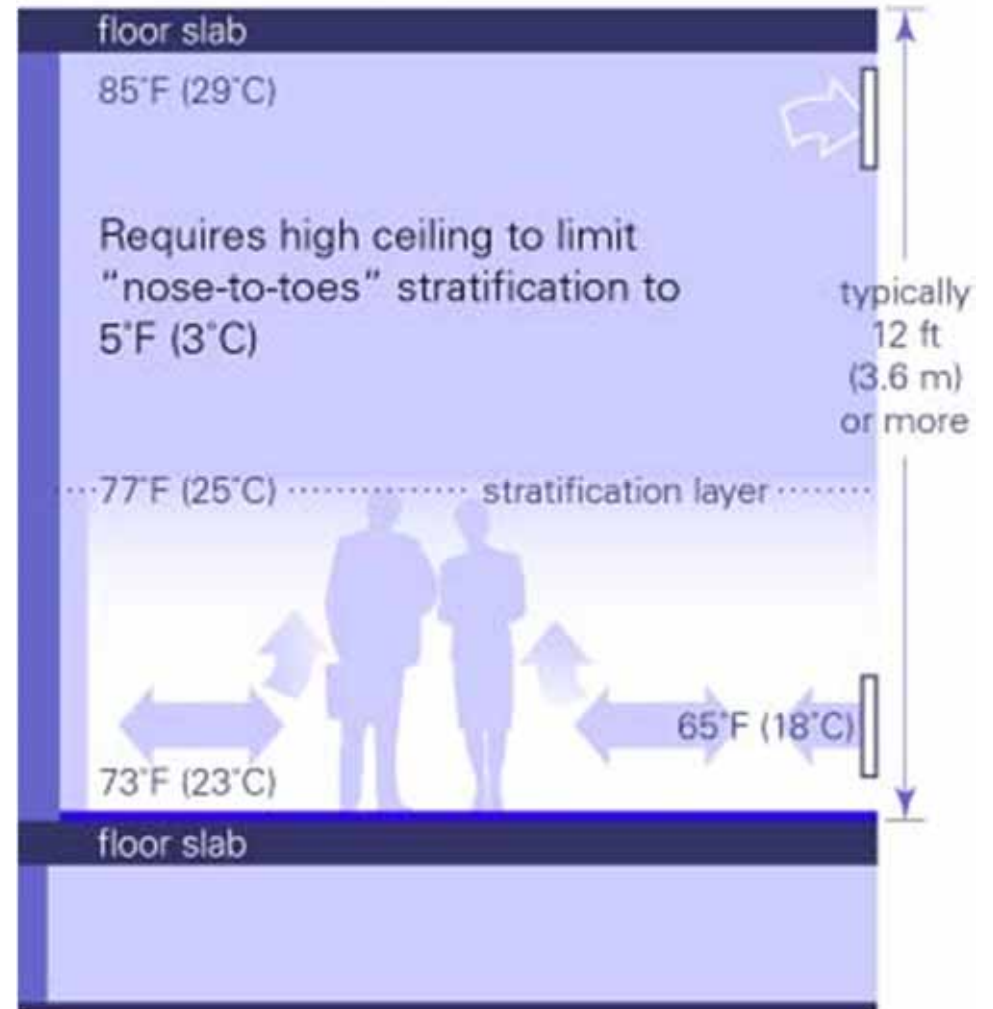

(Source: UC Berkeley)

"Partial" Displacement Ventilation (Underfloor Air Distribution)

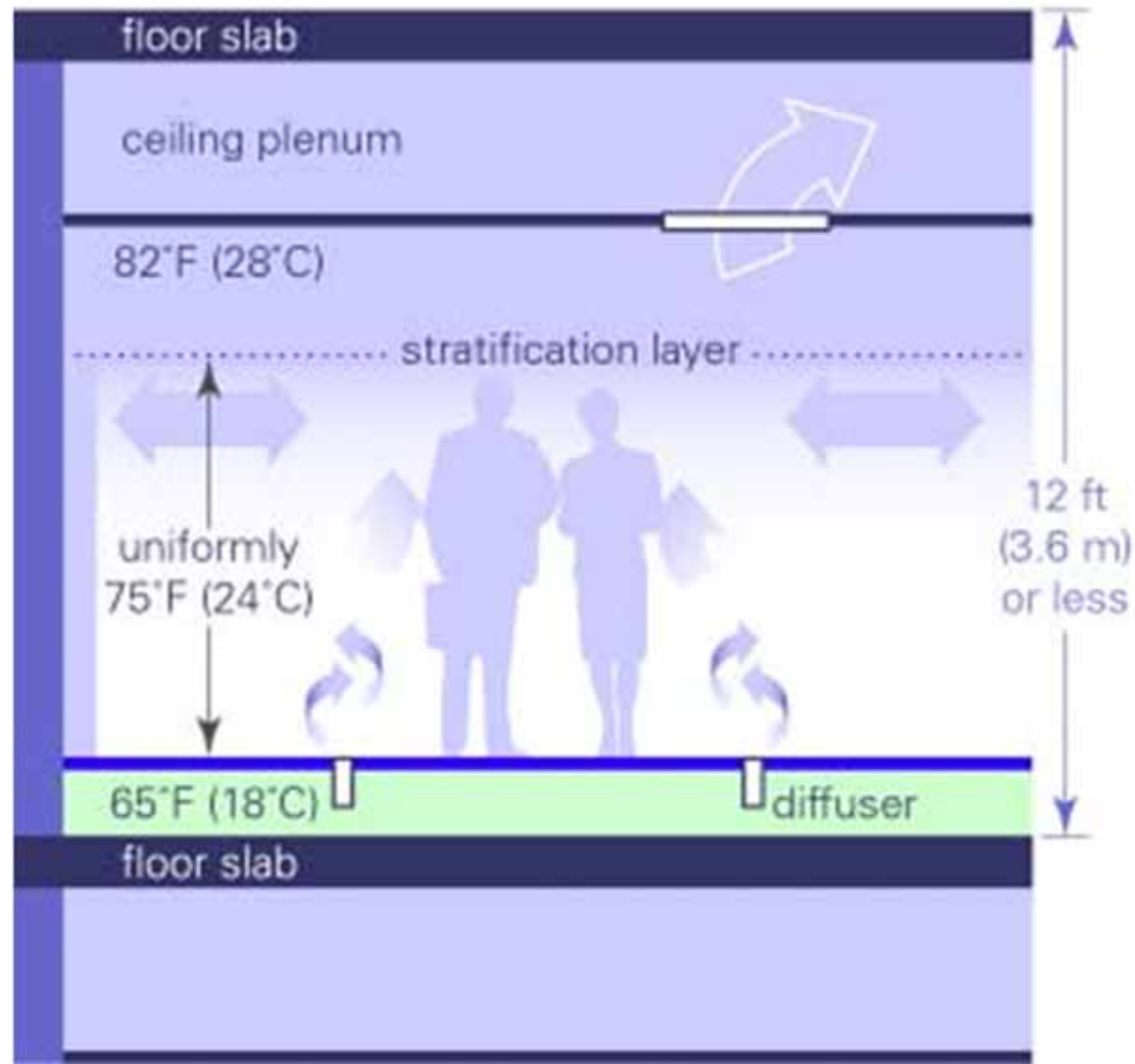

(Source: UC Berkeley)

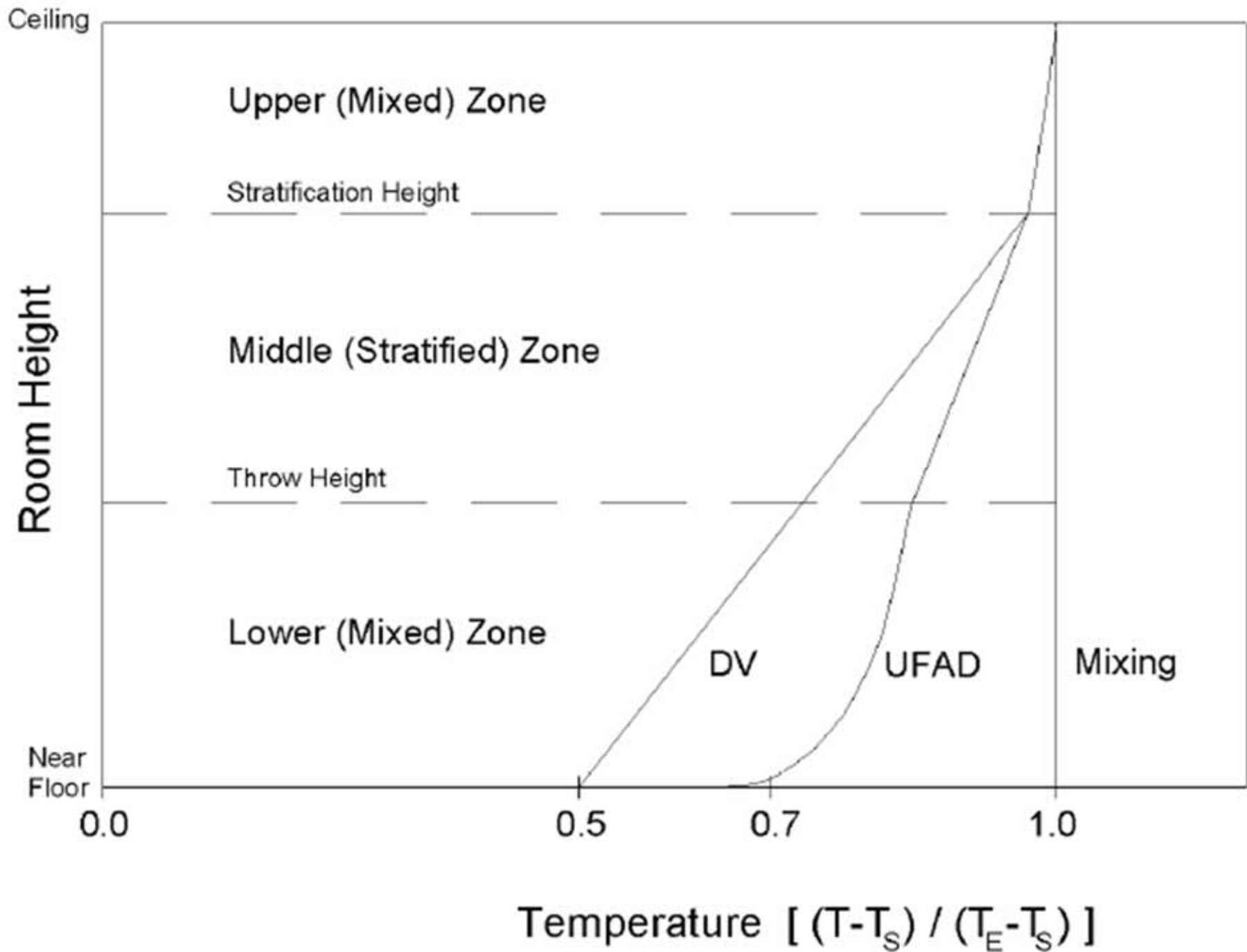

Comparison of typical vertical temperature profiles

(Source: ASHRAE Underfloor Air Distribution Design Guide)

References



- ASHRAE design guides:
 - Bauman, F. S. and Daly, A., 2003. *Underfloor Air Distribution Design Guide*
 - Chen, Q. and Glicksman, L., 2003. *System Performance Evaluation and Design Guidelines for Displacement Ventilation*
- Suppliers information:
 - <http://www.price-hvac.com>
 - <http://www.flexiblespace.com>

Unidirectional Flow



- Unidirectional flow
 - Airstream flows in the same direction as uniform airflow showers the entire working area or occupied zone (known as “[laminar flow](#)”)
 - Examples:
 - Clean rooms (downward or horizontal flow)
 - Ventilating or perforated ceiling
 - Advantages:
 - Contaminants generated cannot move laterally
 - Dust particles will not be carried to higher levels

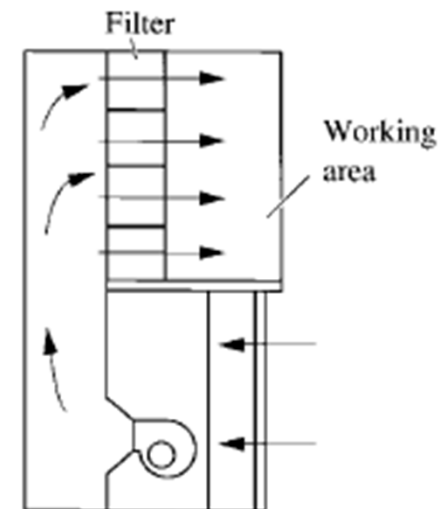
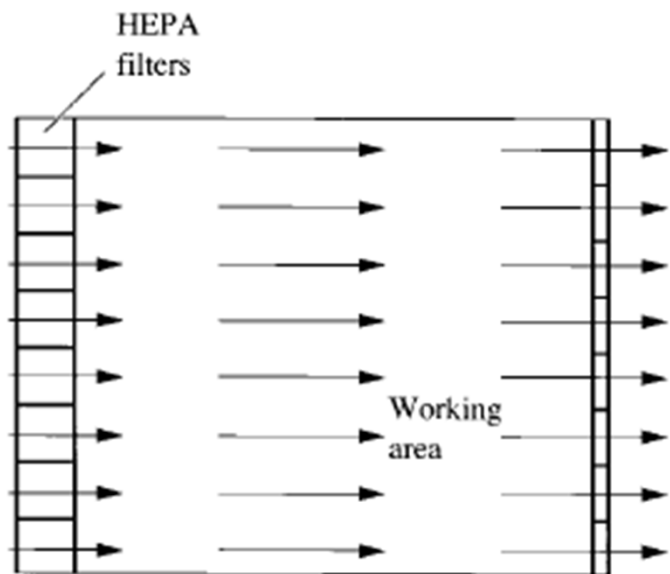
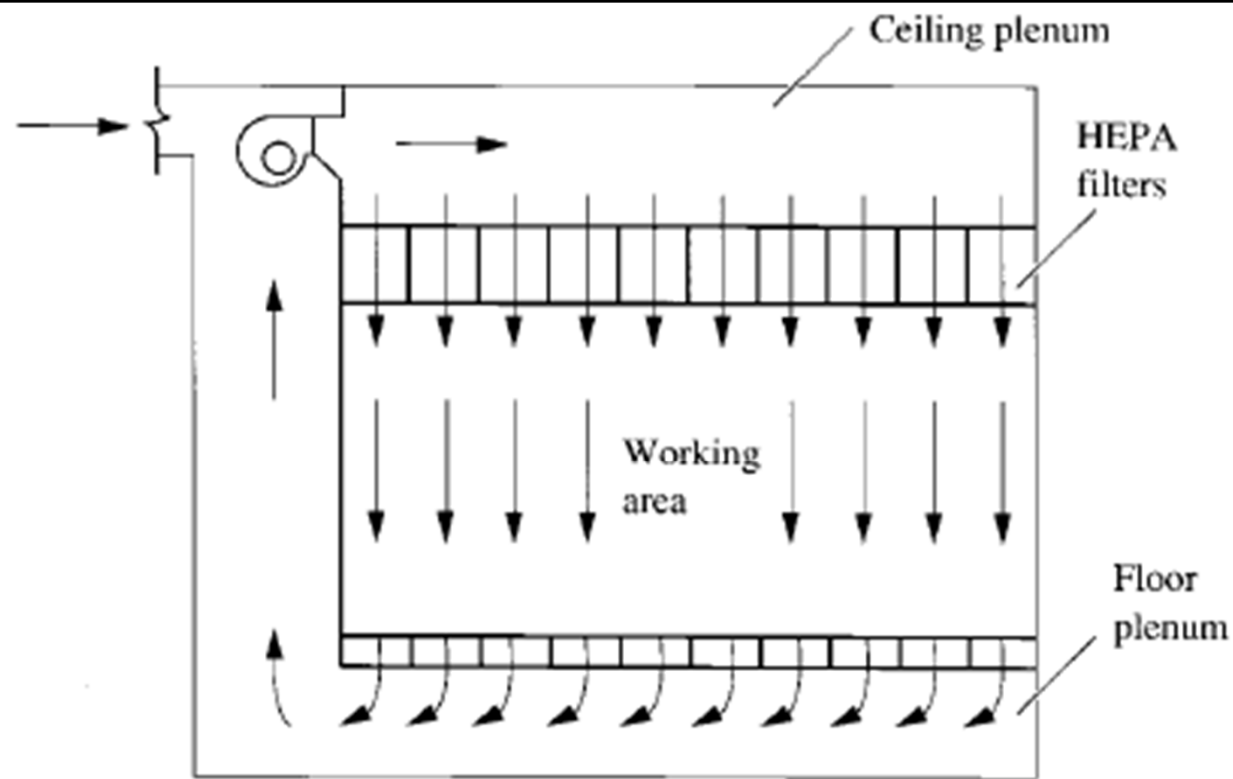

Unidirectional flow for clean rooms

(Source: Wang, S. K., 2001. *Handbook of Air Conditioning and Refrigeration*)

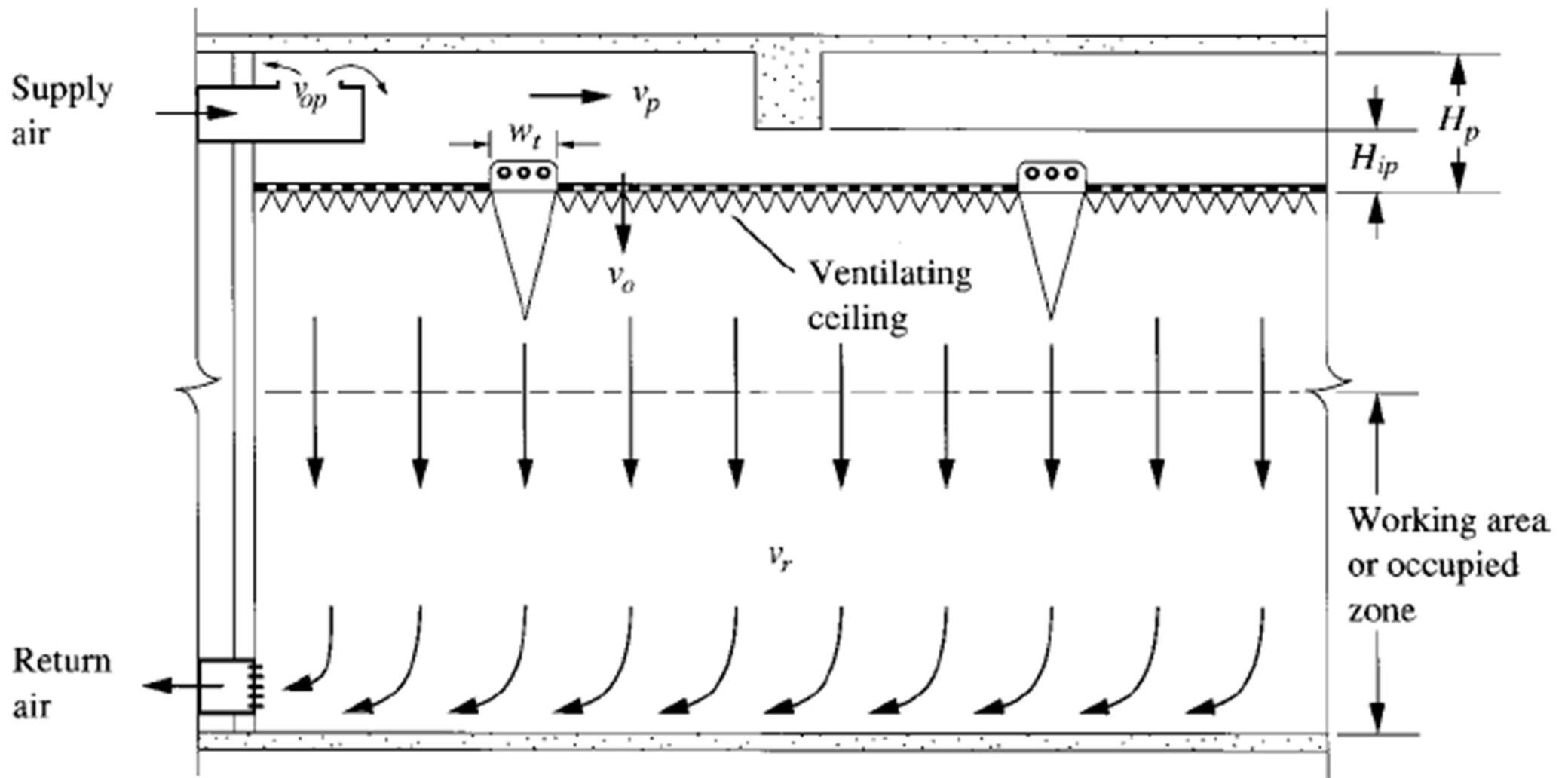

Ventilating ceiling

(Source: Wang, S. K., 2001. Handbook of Air Conditioning and Refrigeration)

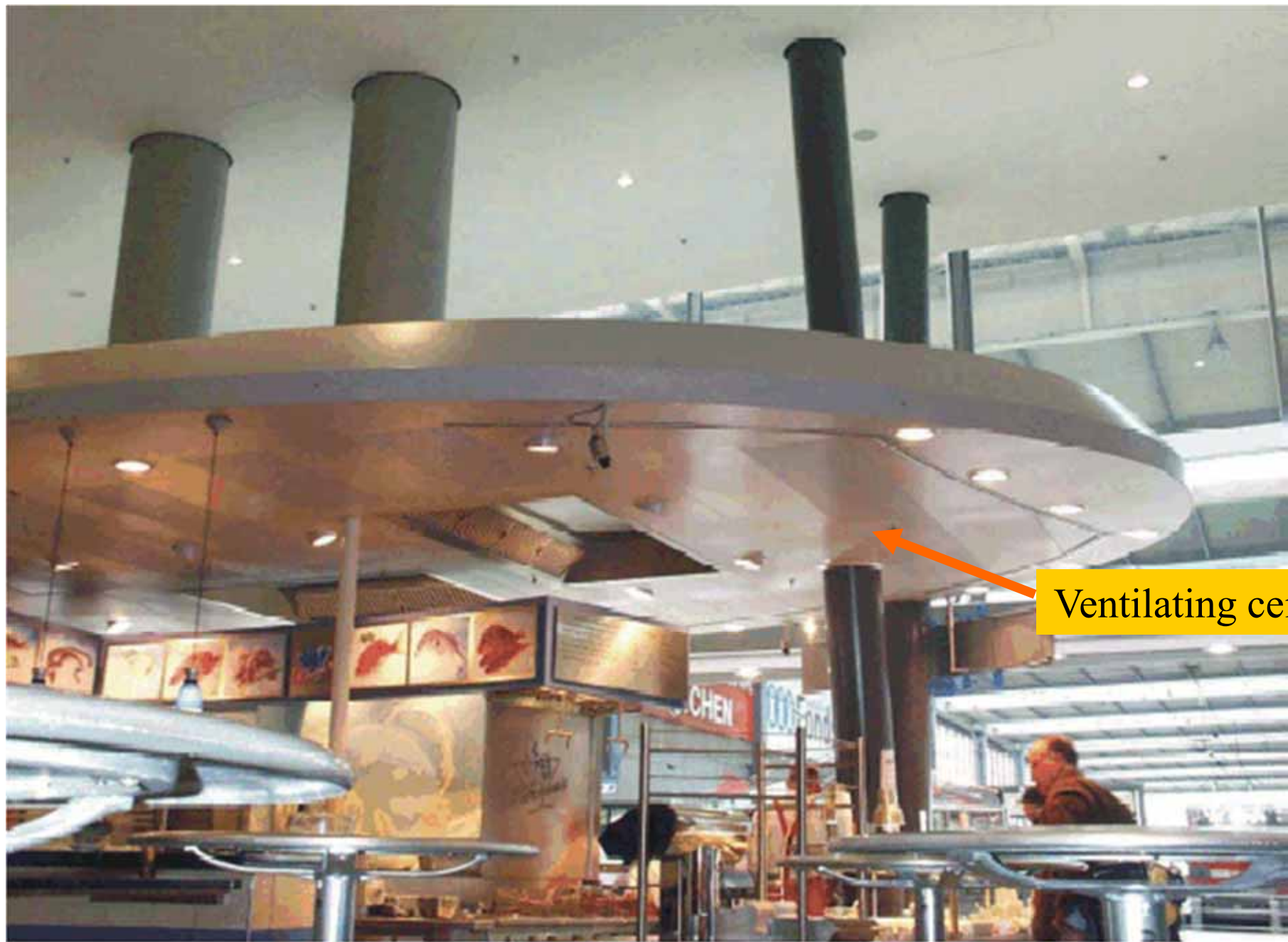

Ventilating ceiling: an example for kitchen

(Source: <http://www.reven.de>)

Unidirectional Flow



- Ceiling plenum & supply air velocity
 - To create a more uniform supply air velocity, the max. air velocity inside the ventilating ceiling plenum shall be low
 - If sufficient plenum height & few obstructions, distributing ductwork inside is not needed
- Applications of ventilating ceiling
 - Industrial process
 - Indoor sports stadium for badminton (< 0.2 m/s)

Unidirectional Flow



- Hospital applications (more critical)
 - Main purpose: control of airborne contaminants
 - Such as operating theatre and isolation wards
- Operating theatre
 - Large fresh air ventilation (100% outdoor air)
 - Large volume of supply air
 - At low uniform velocity to promote stable downward flow of air

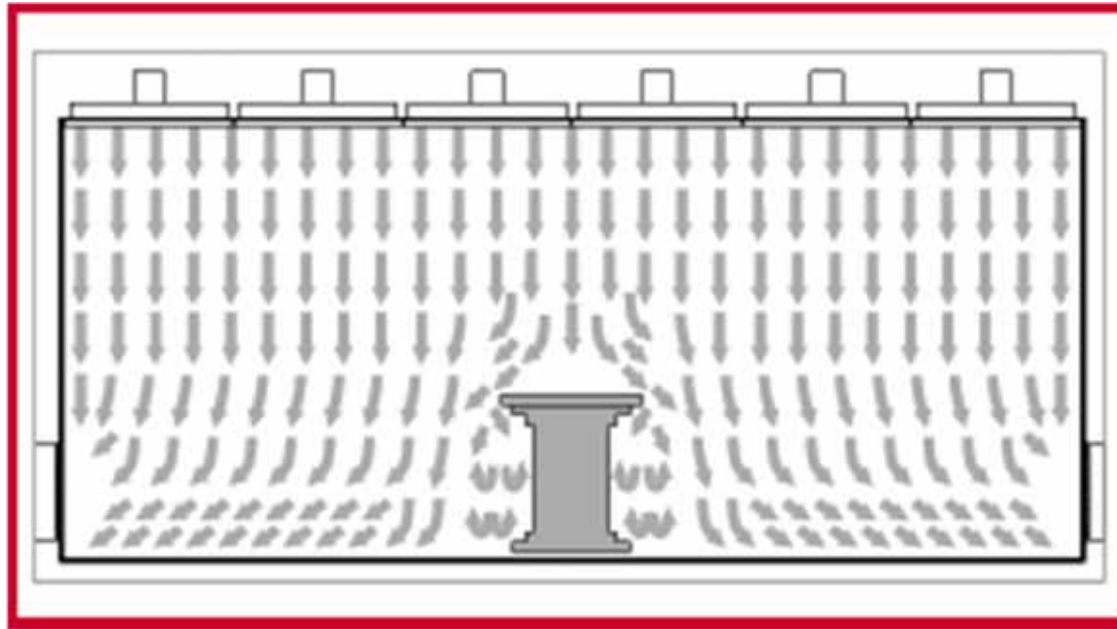

Laminar flow -
full ceiling
supply

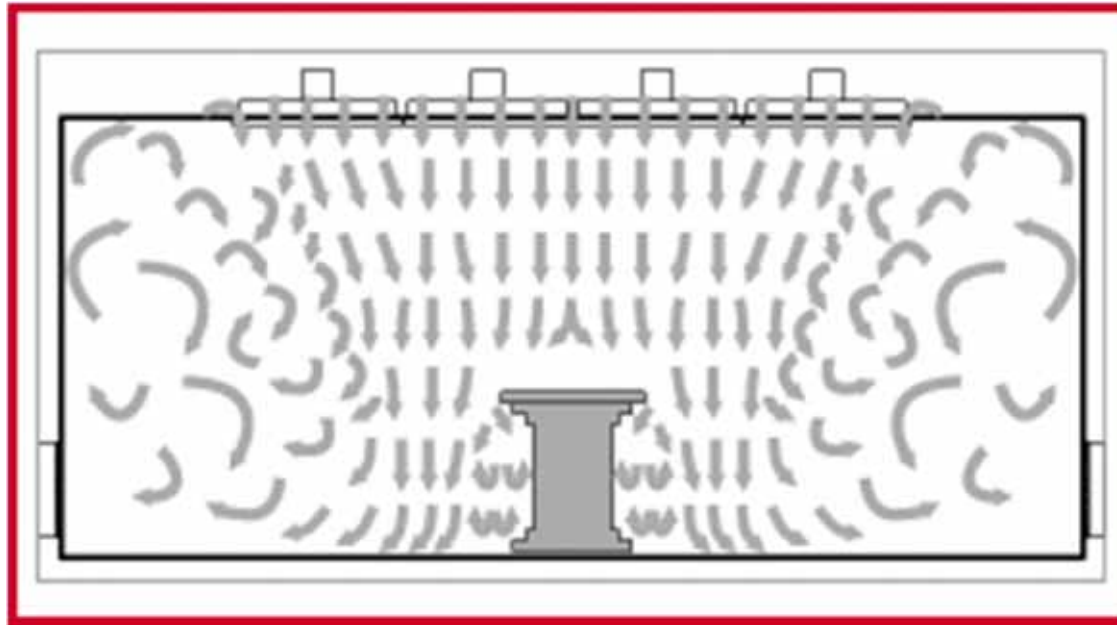

Laminar flow -
partial ceiling
supply

Flow patterns in hospital operating theatre

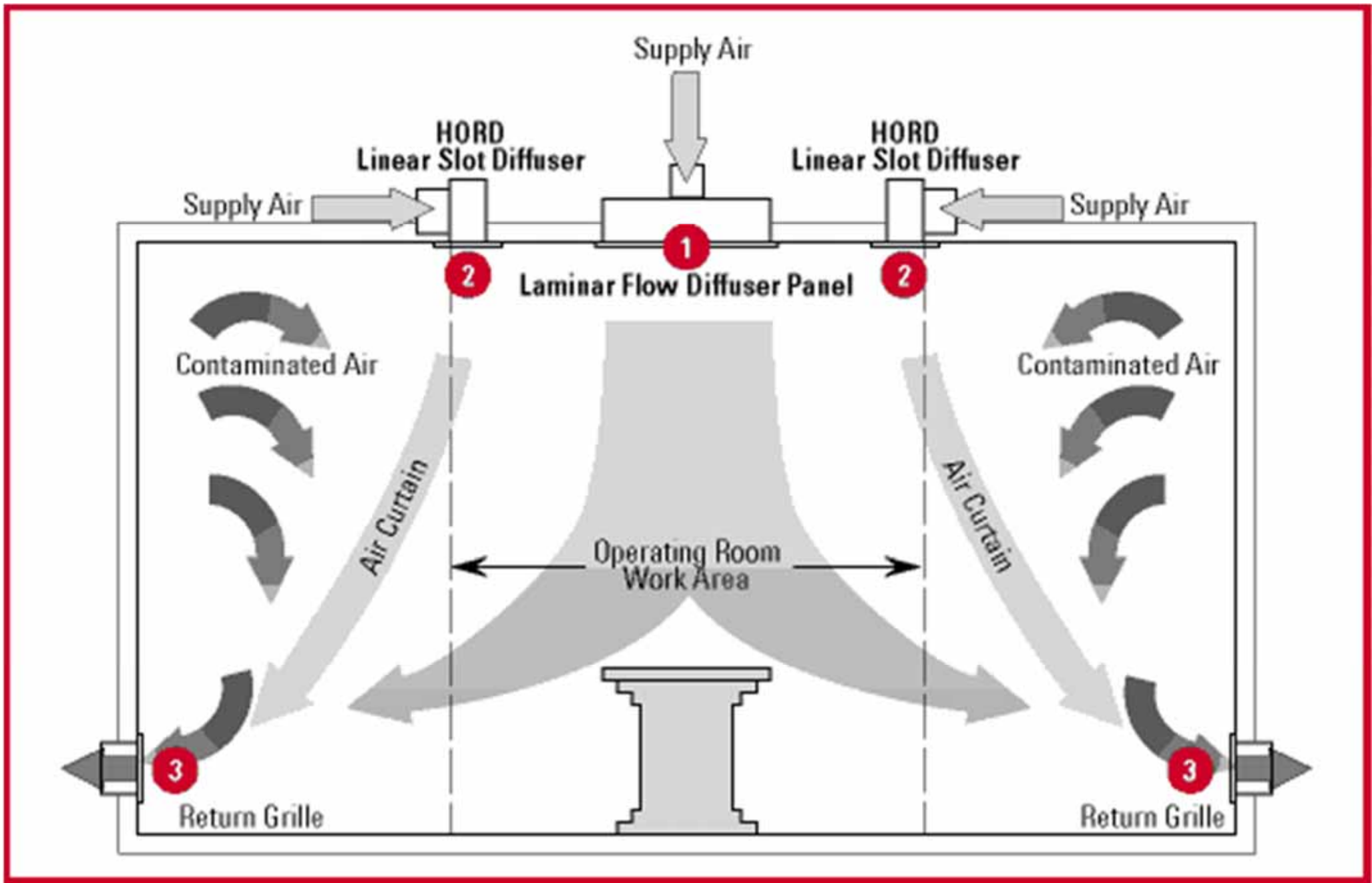

Hospital operating theatre (laminar flow with air curtains)

(Source: <http://www.price-hvac.com>)



Hospital operating theatre (typical design)

(Source: <http://www.price-hvac.com>)



- HORD**
Hospital Operating Room Diffuser
- Linear slot discharges vertical curtain of clean air.
 - Creates a “room within a room” around perimeter of operating table work area.
 - Single or multiple side feeds from supply air plenum.

- LFD / LFDSS / LFD2**
Laminar Flow Diffuser
- Perforated face discharges non-aspirating (non-mixing) vertical flow of clean air.
 - Air pattern “flows” over the operating table on its way to the floor.
 - Creates a “washing” and “rinsing” effect.

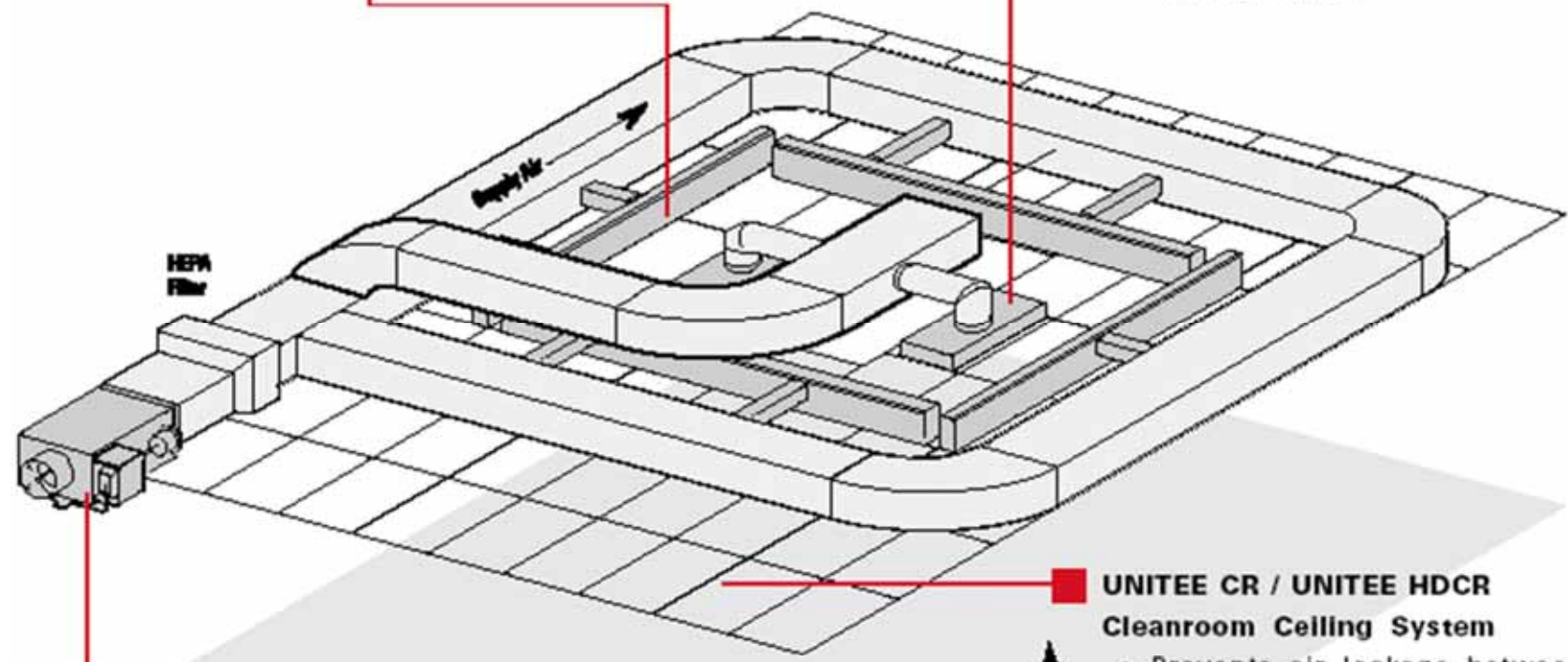

- Terminal Units for Cleanrooms**
- A variety of liner options are available.
 - Reduces risk of micro-organism growth.
 - Prevents fibrous particles from entering supply air stream.

- UNITEE CR / UNITEE HDCR**
Cleanroom Ceiling System
- Prevents air leakage between plenum and operating room.
 - Utilizes unique hold-down clip and gasketed tee design.
 - Ceiling panels available specific to applications.

Hospital operating theatre (typical design)

(Source: <http://www.price-hvac.com>)

Unidirectional Flow



- Hospital applications - isolation wards
 - Infectious isolation rooms
 - Patients with infectious diseases
 - Kept at a negative pressure
 - Protective isolation rooms
 - Patients with a high susceptibility to infection
 - Kept at a positive pressure
 - HEPA filters will be used
 - Ante rooms are recommended to minimize exchange of air between a hallway and the isolation room
 - Airflow pattern: protect health care staff or patient



Diagram #1 - Infectious Isolation Room

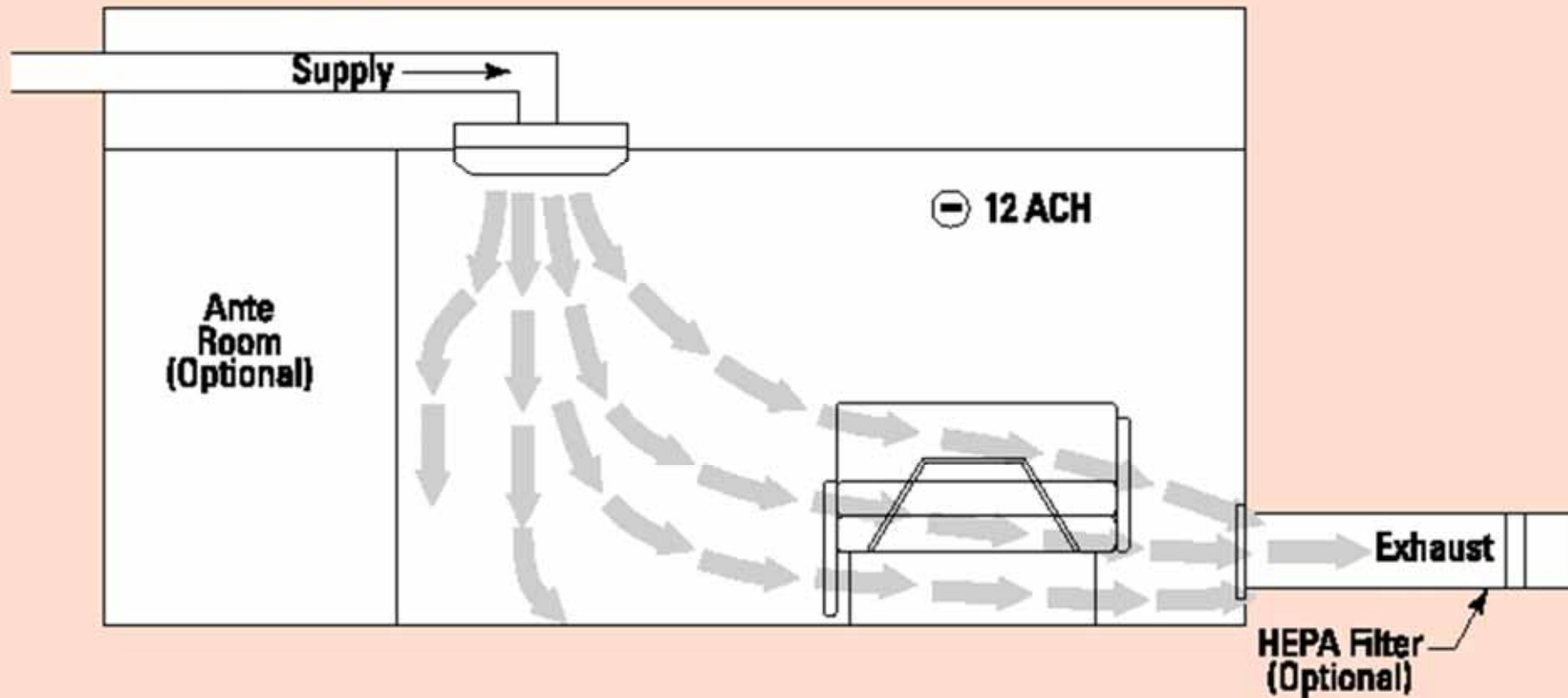

Infectious isolation room

(Source: <http://www.price-hvac.com>)

Diagram #2 - Protective Isolation Room

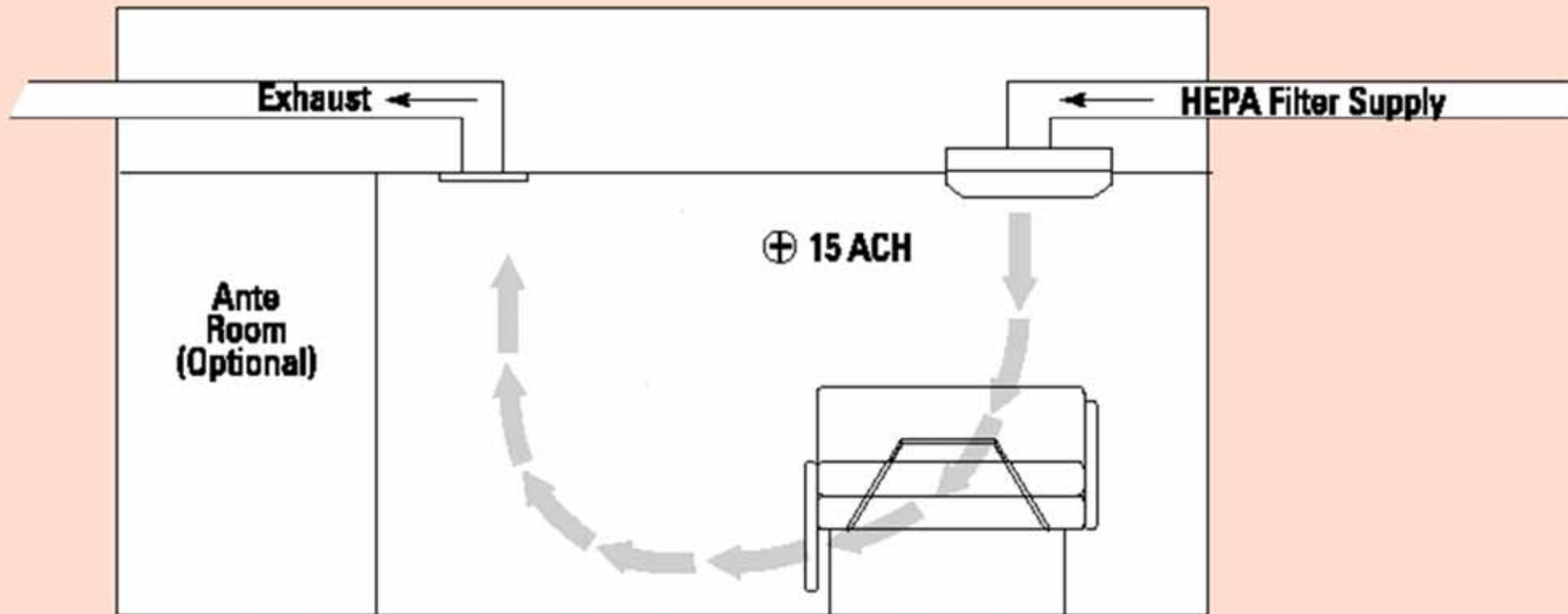

Protective isolation room

(Source: <http://www.price-hvac.com>)



SARS test chamber (inside HKU BSE Lab)

Projecting Flow



- Cold or warm air jet projected to target zone
- Benefits of projecting flow
 - Better control of temp., air cleanliness & air movement in a localised environment
 - Spot cooling improve occupants' thermal conditions & reduce heat stress
 - Greater direct outdoor air supply
 - Direct & efficient handling of local loads
 - Greater control of their own micro-environment

Projecting Flow



- Disadvantages of projecting flow
 - Draft discomfort or pressure air jet
 - Limited area of environmental control
 - More complicated space air diffusion design
- Usually free jets with high entrainment ratios
 - Long-throat round nozzles are often used
- Two types of projecting flow
 - Industrial spot cooling systems
 - Desktop task air conditioning systems

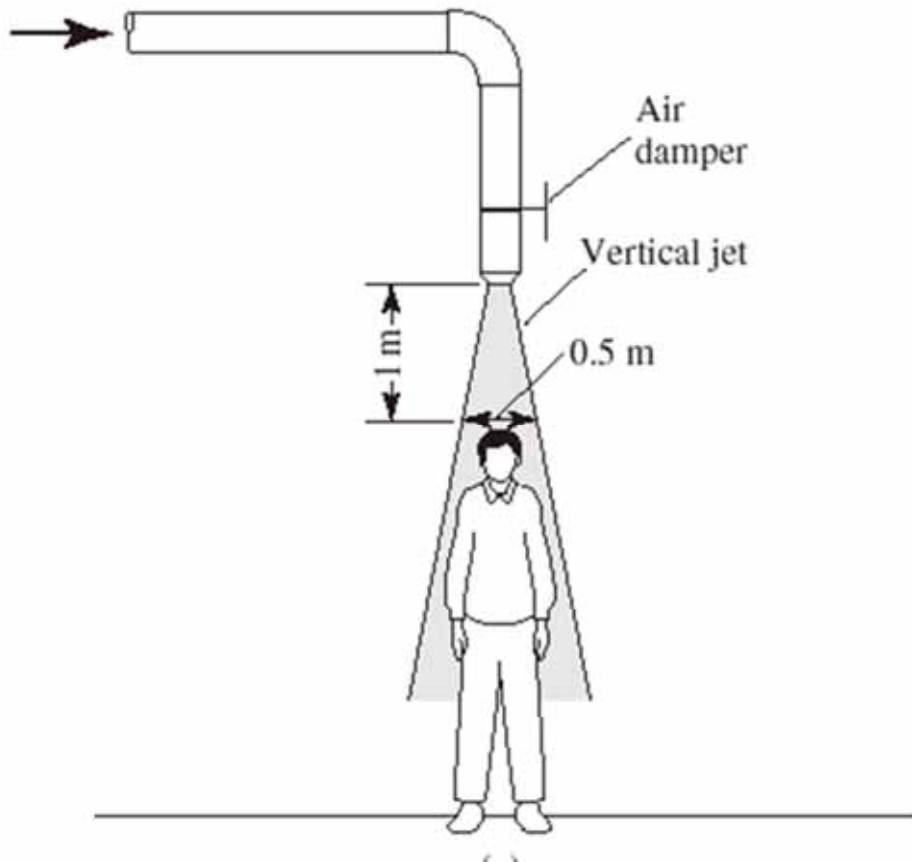

Industrial spot cooling system

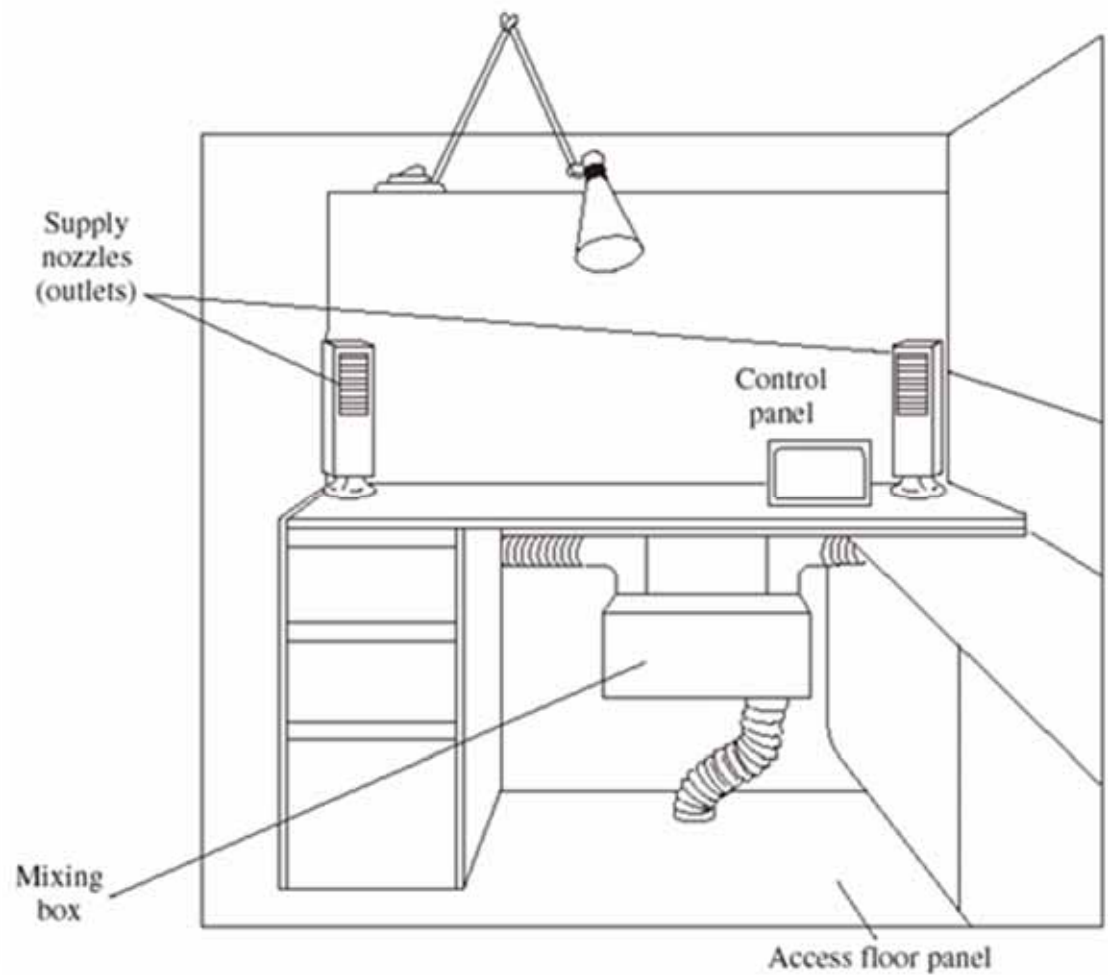

Desktop task air conditioning

(Source: Wang, S. K., 2001. Handbook of Air Conditioning and Refrigeration)

Projecting Flow



- Industrial spot cooling systems
 - Temperature difference between target zone & the room air is often 2.8 °C or greater
 - Distance between target zone & supply outlet
 - Vertical vs horizontal jet
 - Target velocities
 - Thermal sensation
 - Of whole body & for individual parts (local)
 - Allow occupants to have individual control

Projecting Flow



- Desktop task conditioning systems
 - Also task/ambient conditioning (TAC)
 - Typical design: self-powered mixing box, small supply fans, desktop supply outlets (nozzles), flexible ducts + control panel
 - Also integration with furniture or partitions
 - Advantages:
 - Allow occupants to fine-tune the local environment
 - Possible to off the unit when unoccupied to save energy
 - Direct supply of primary air to occupants

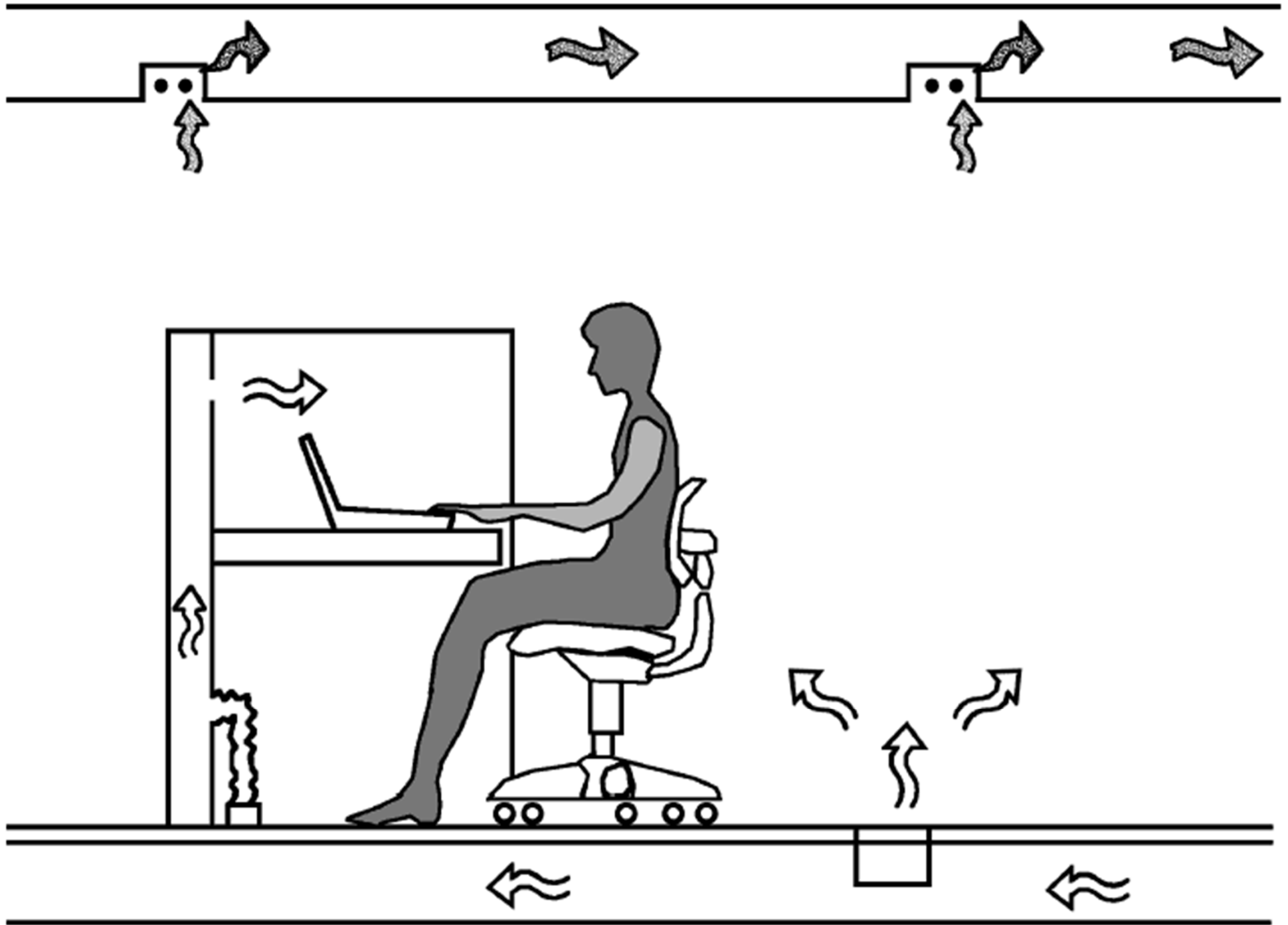

(Source: *ASHRAE Underfloor Air Distribution Design Guide*)

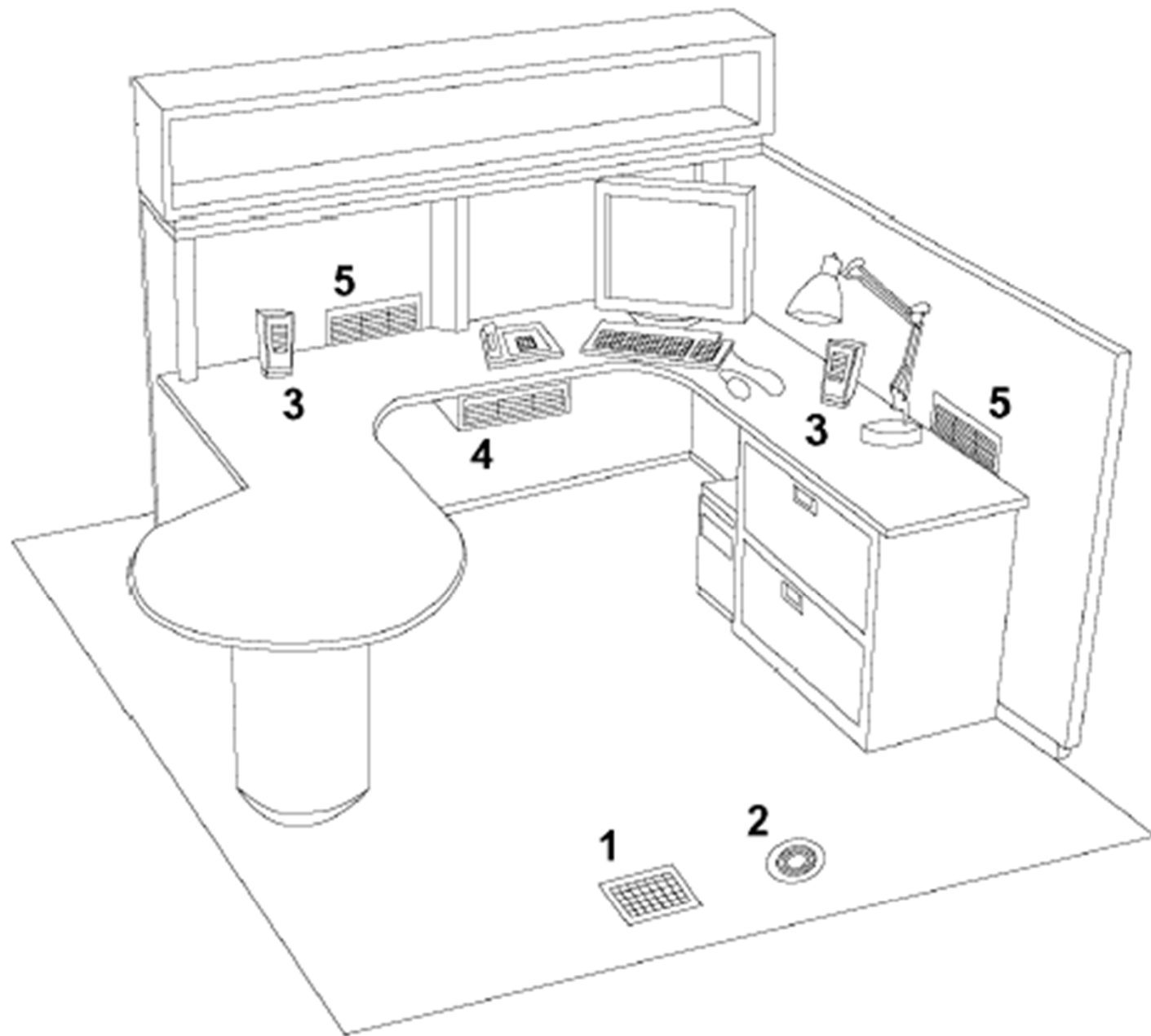

Figure 5.1 UFAD and TAC diffuser locations in a workstation.

(Source: *ASHRAE Underfloor Air Distribution Design Guide*)

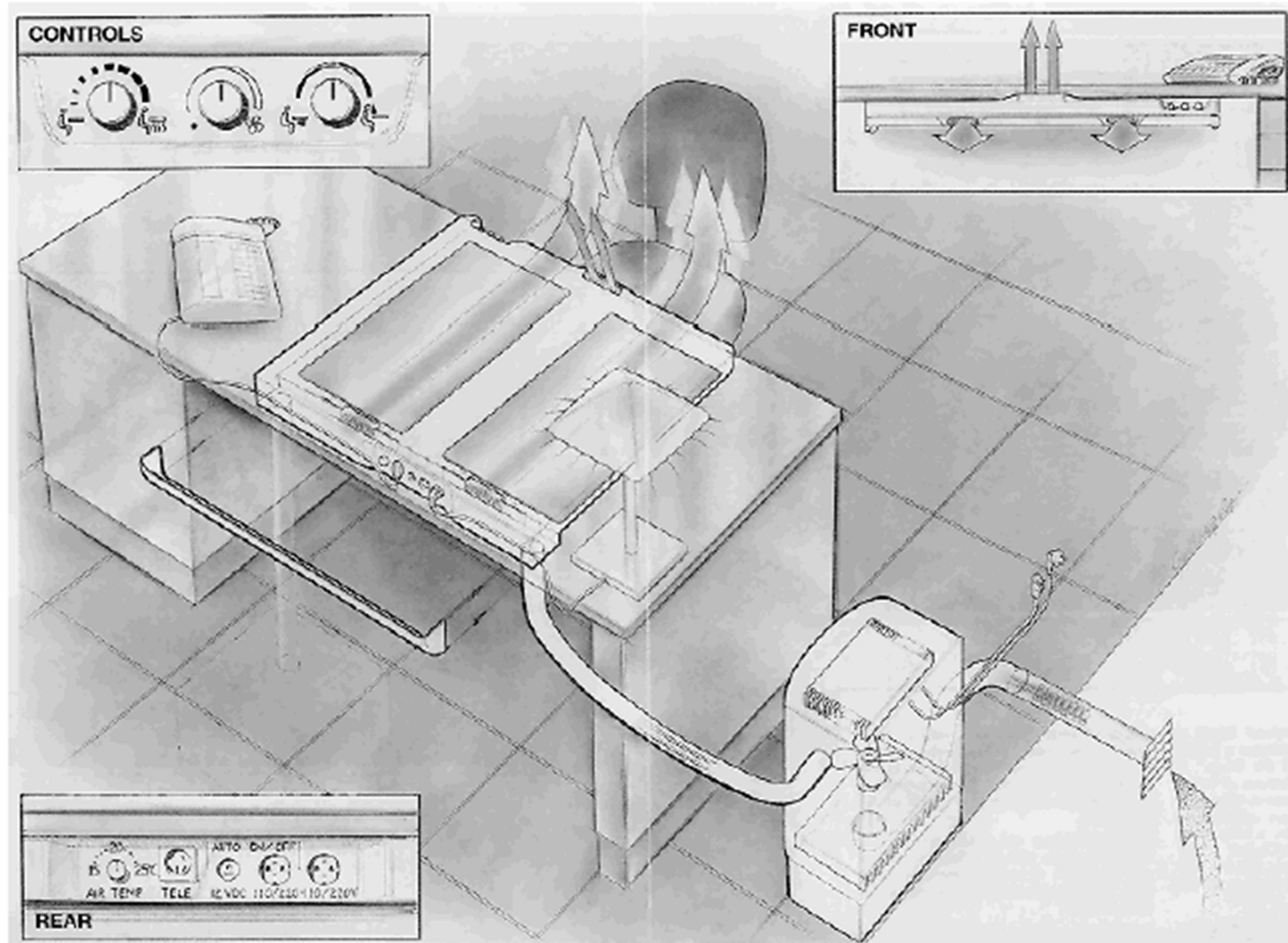

Figure 5.12 Underdesk TAC supply unit [Johnson Controls 2002].

(Source: *ASHRAE Underfloor Air Distribution Design Guide*)

Air Flow Analysis



- Computational fluid dynamics (CFD)
 - Computing technique for analysis & prediction of fluid motion and heat transfer
 - Using Navier-Stokes & thermal equations
 - Become more and more popular for study of air flow patterns, indoor temperature distribution & indoor contaminants
 - Useful tool for studying space air diffusion

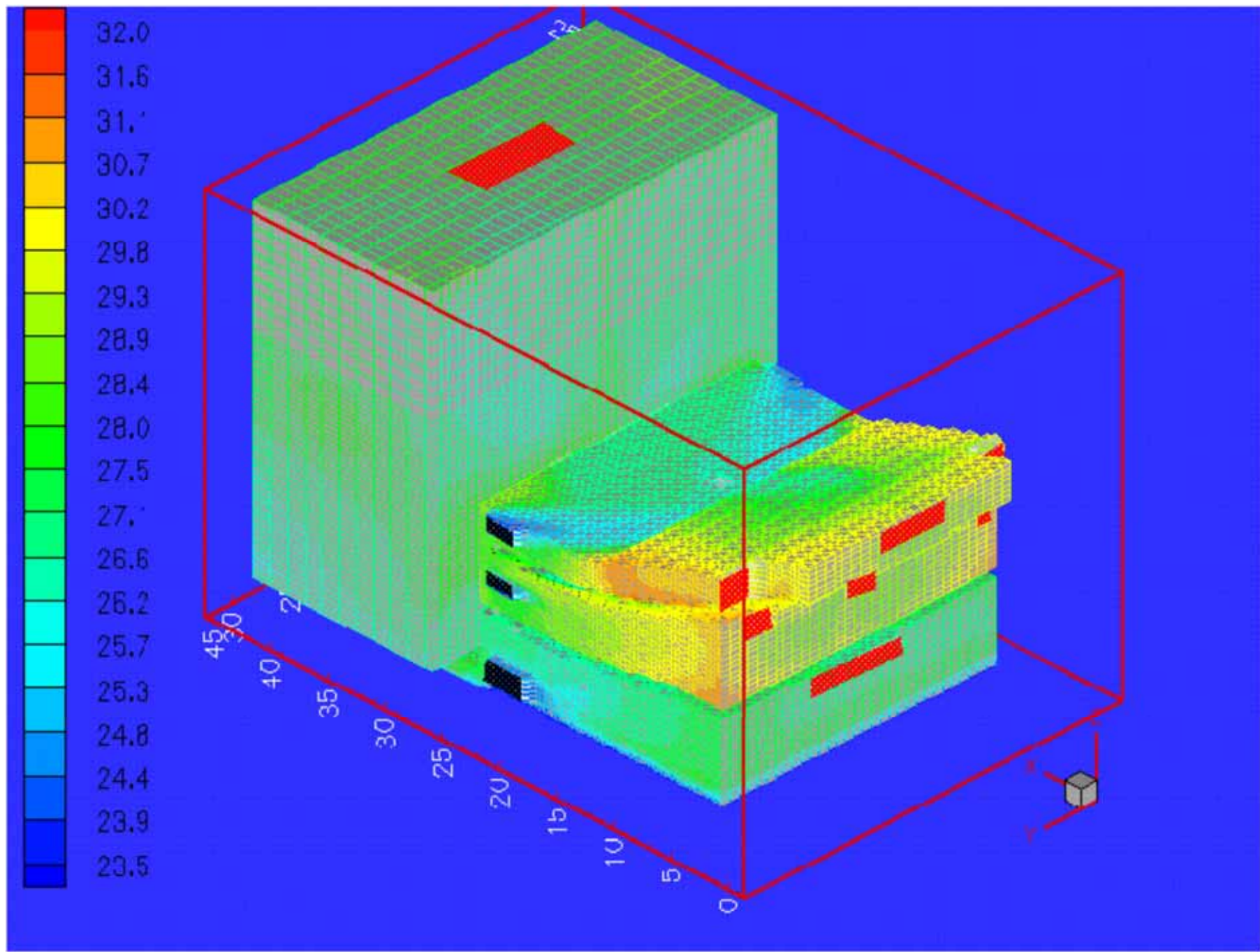

CFD visualisation – temp. distribution (St. James Theatre, Australia)

(Source: Dr. Yuguo Li, Dept of Mech Engg, HKU)

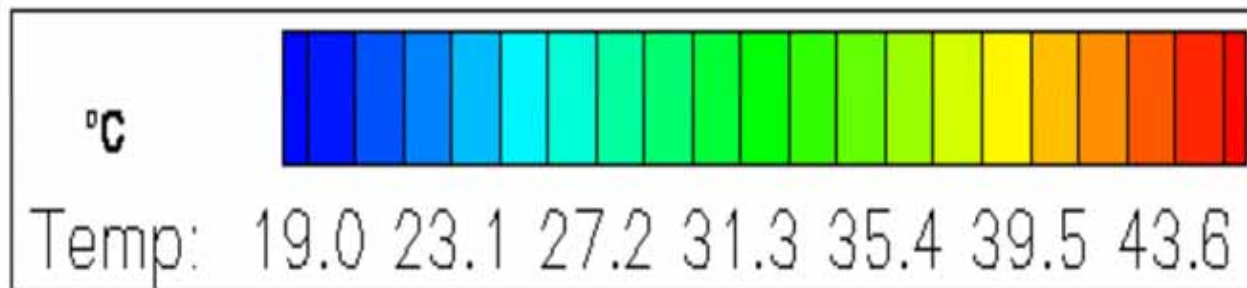
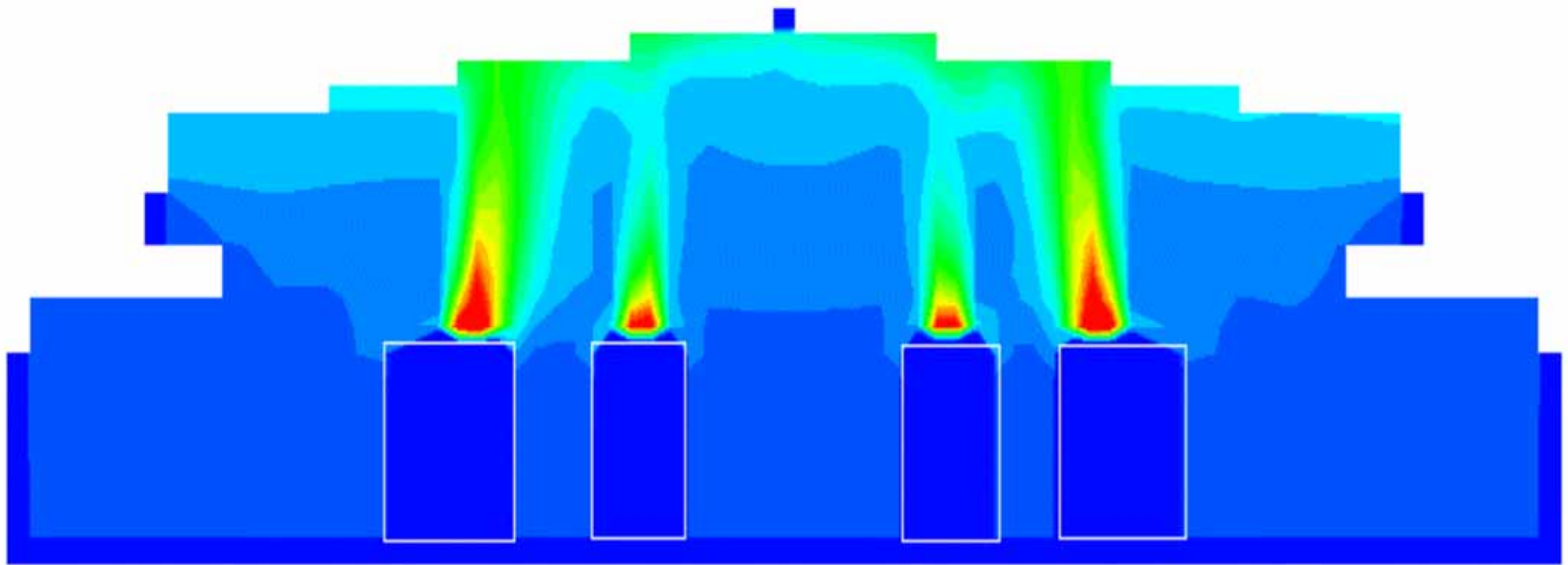

CFD visualisation – temp. distribution (Sydney Fruit Market)

(Source: Dr. Yuguo Li, Dept of Mech Engg, HKU)

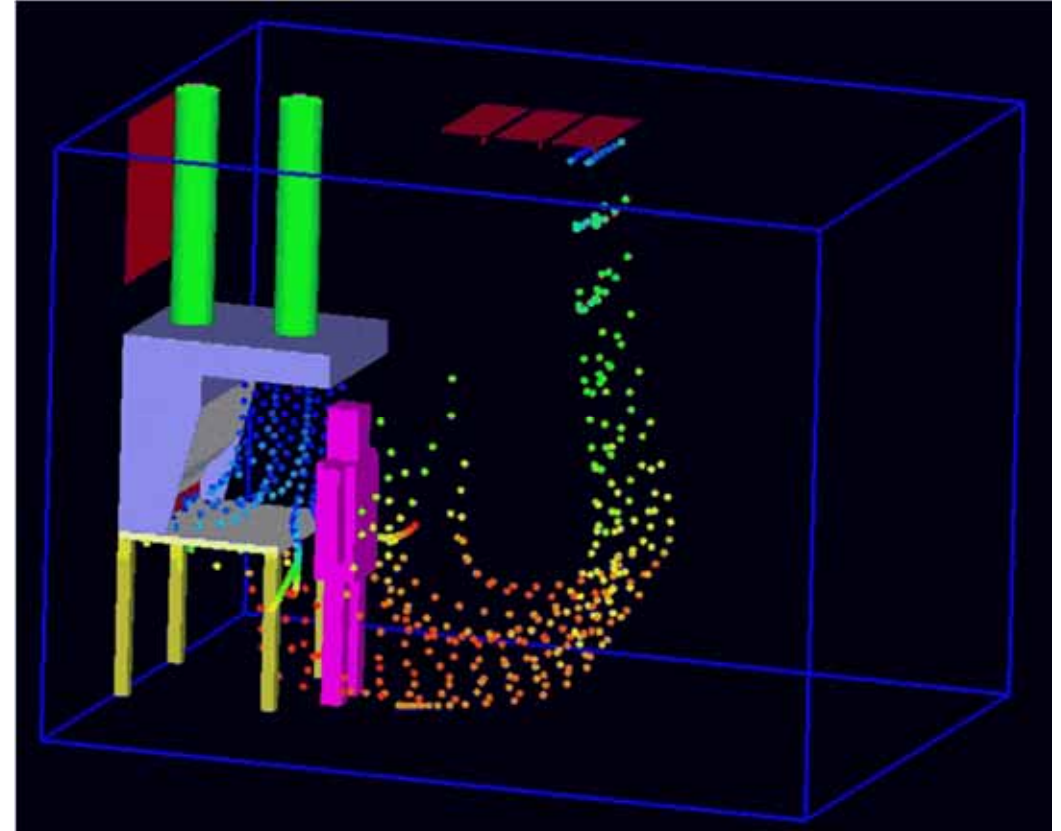
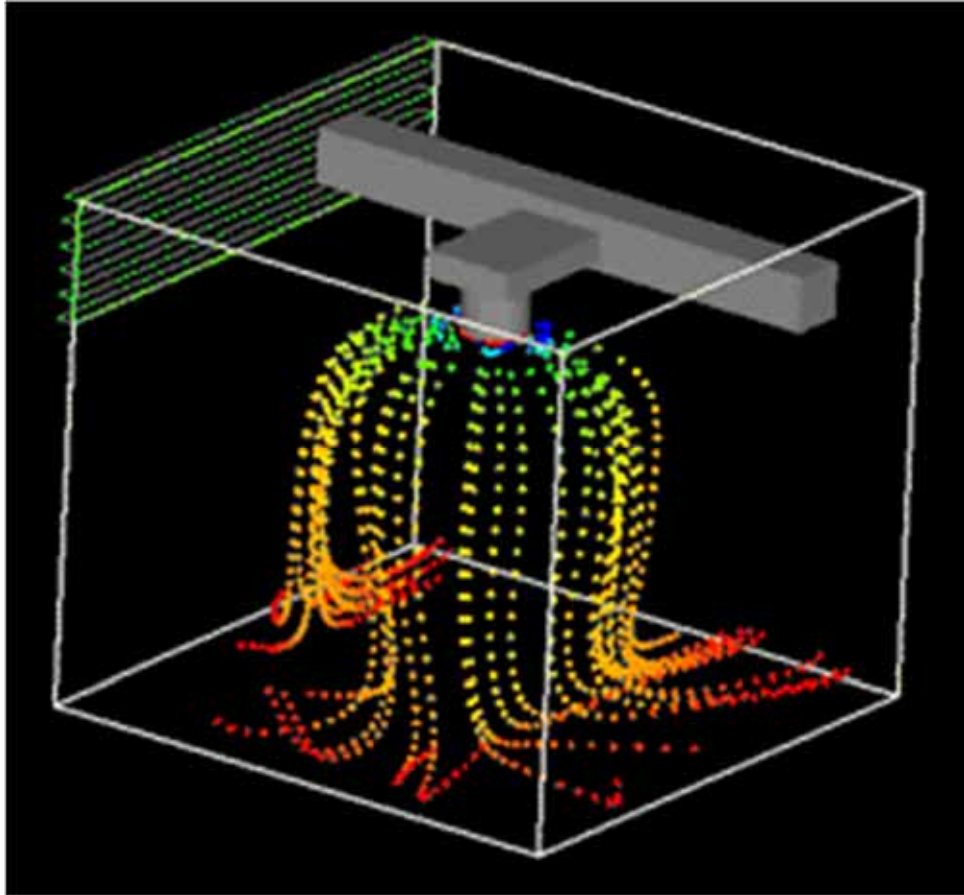

Computational fluid dynamics (CFD) applied to airflow study

(Source: <http://www.fluent.com/>)

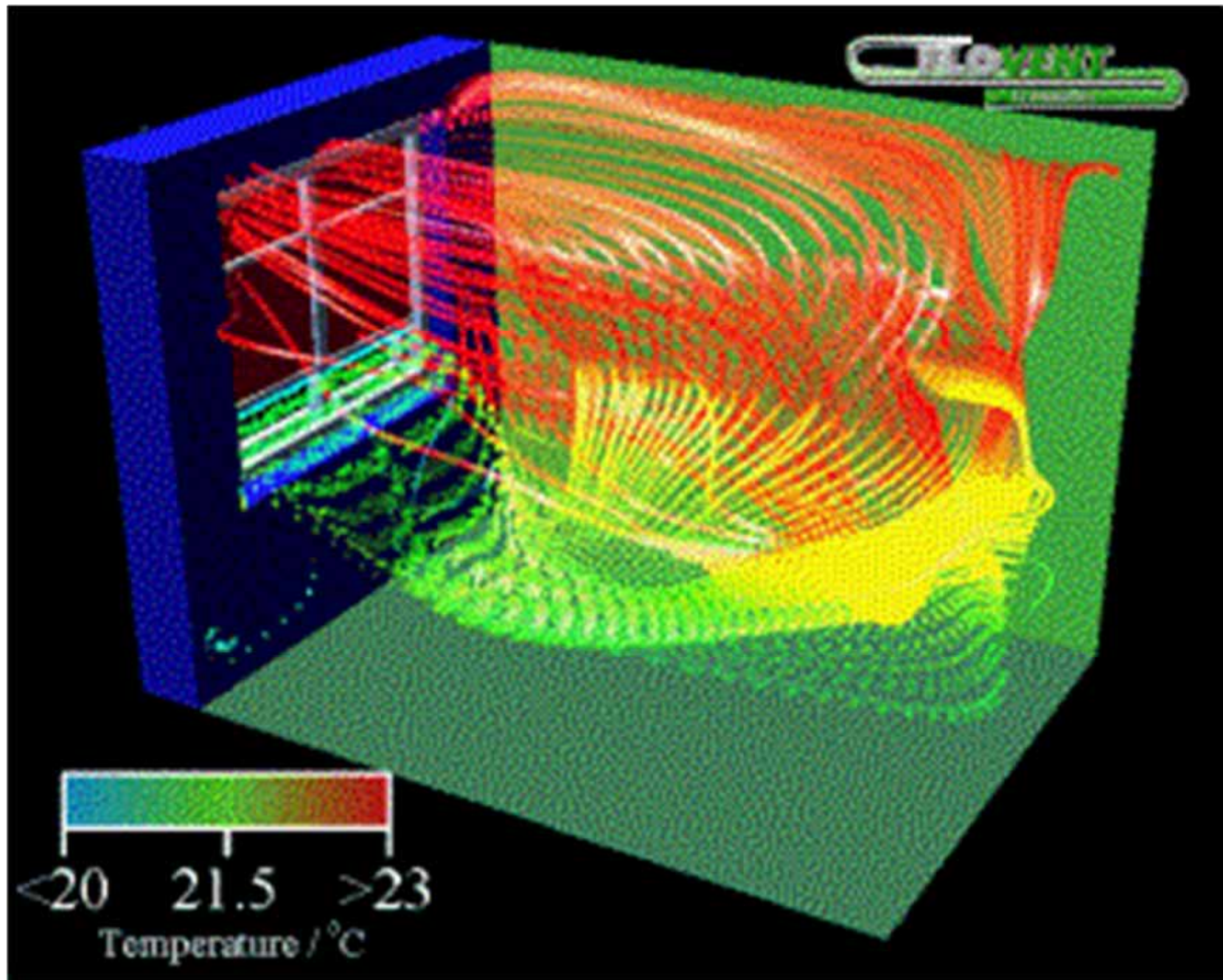

CFD applied to naturally ventilated buildings

(Source: <http://www.flovent.com>)

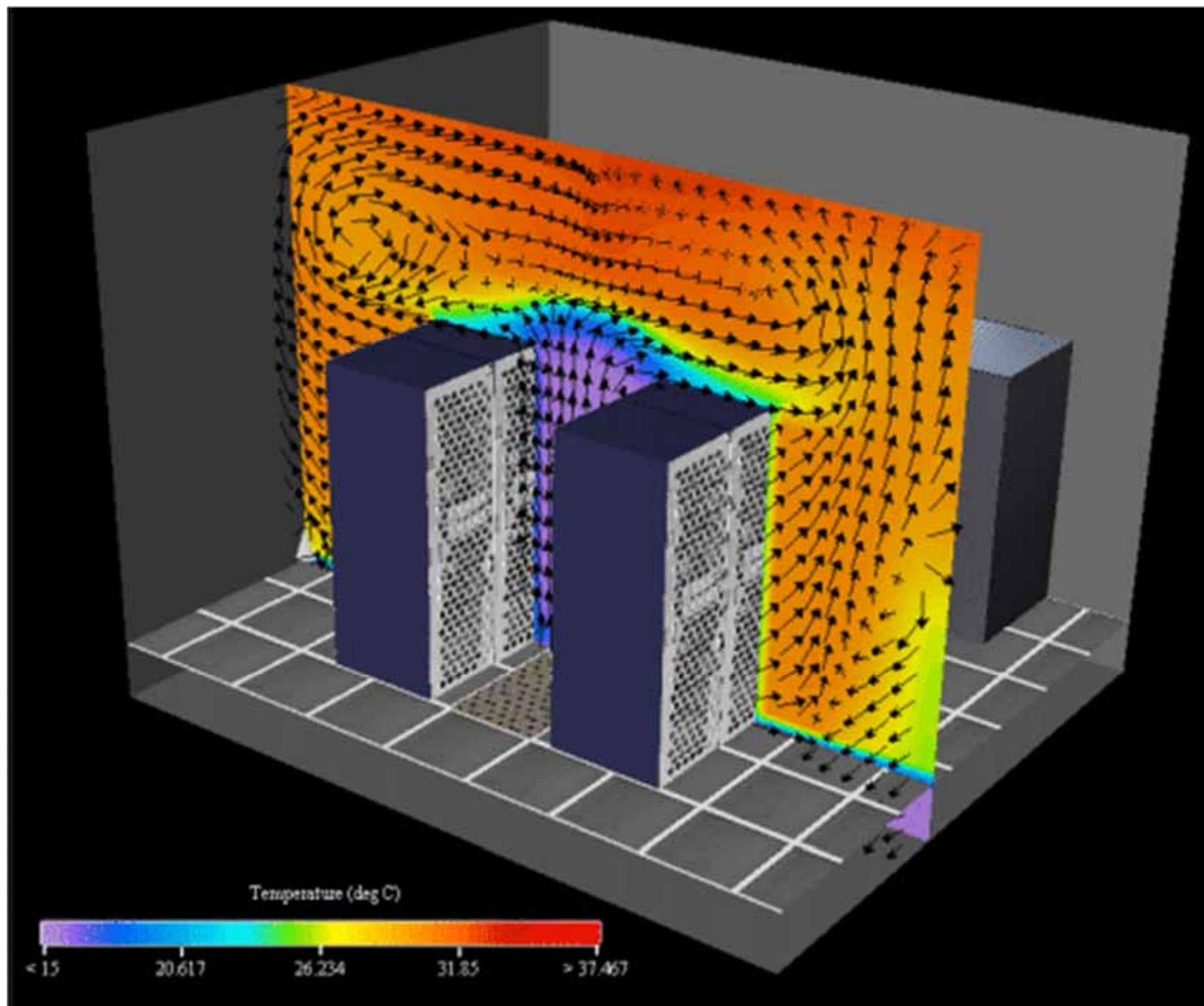

CFD applied to data centre design study

(Source: <http://www.flovent.com>)

Air Flow Analysis



- Computational fluid dynamics (CFD)
 - Turbulence modelling methods
 - Correlations, e.g. drag as a function of Re
 - Integral methods
 - Reynolds average models (κ - ε models)
 - Large eddy simulation (LES)
 - Direct numerical simulation (DNS)
 - Time average Navier-Stokes equations
 - Incompressible form of the momentum equation
 - Full and general set of partial differential equations governing fluid motion

Air Flow Analysis



- Computational fluid dynamics (CFD)

- Governing equations:-

Fluid density (ρ)

Velocity (U, V, W)

- Mass balance:
$$\frac{\partial \rho}{\partial t} + \frac{\partial}{\partial x}(\rho U) + \frac{\partial}{\partial y}(\rho V) + \frac{\partial}{\partial z}(\rho W) = 0$$

- Momentum:

Viscosity (μ)

x-momentum
y-momentum
z-momentum

$$\left. \begin{array}{l} \frac{\partial}{\partial t}(\rho U) + \frac{\partial}{\partial x}(\rho U U) + \frac{\partial}{\partial y}(\rho U V) + \frac{\partial}{\partial z}(\rho U W) \\ = -\frac{\partial P}{\partial x} + \frac{\partial}{\partial x}\left(\mu \frac{\partial U}{\partial x}\right) + \frac{\partial}{\partial y}\left(\mu \frac{\partial U}{\partial y}\right) + \frac{\partial}{\partial z}\left(\mu \frac{\partial U}{\partial z}\right) + \frac{1}{3} \frac{\partial}{\partial x} \left[\mu \left(\frac{\partial U}{\partial x} + \frac{\partial V}{\partial y} + \frac{\partial W}{\partial z} \right) \right] + \rho g_x \end{array} \right\}$$

- Energy:

$$\frac{\partial}{\partial t}(\rho \Gamma^*) + \frac{\partial}{\partial x}(\rho U \Gamma^*) + \frac{\partial}{\partial y}(\rho V \Gamma^*) + \frac{\partial}{\partial z}(\rho W \Gamma^*) = \frac{\partial}{\partial x}\left(\Gamma \frac{\partial \Gamma^*}{\partial x}\right) + \frac{\partial}{\partial y}\left(\Gamma \frac{\partial \Gamma^*}{\partial y}\right) + \frac{\partial}{\partial z}\left(\Gamma \frac{\partial \Gamma^*}{\partial z}\right)$$

Temperature (T^*)

Diffusivity (Γ)

References



- The Basics of Computational Fluid Dynamics Modeling
 - <http://www.flow3d.com/CFD-101/CFD101.htm>
- Navier-Stokes Equations (Foundations of Fluid Mechanics)
 - <http://www.navier-stokes.net/>
- FLOVENT Applications
 - <http://www.flovent.com/applications/>