

MEBS6008 Environmental Services II

<http://www.mech.hku.hk/bse/MEBS6008/>

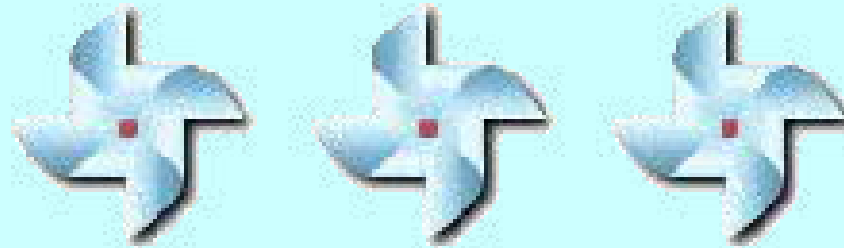

Fans and Pumps II



Dr. Sam C. M. Hui

Department of Mechanical Engineering

The University of Hong Kong

E-mail: cmhui@hku.hk

Jan 2015

Contents



- Fan Design
- Fan Performance
- Fan-duct Systems
- Duct Construction
- Air Duct Design

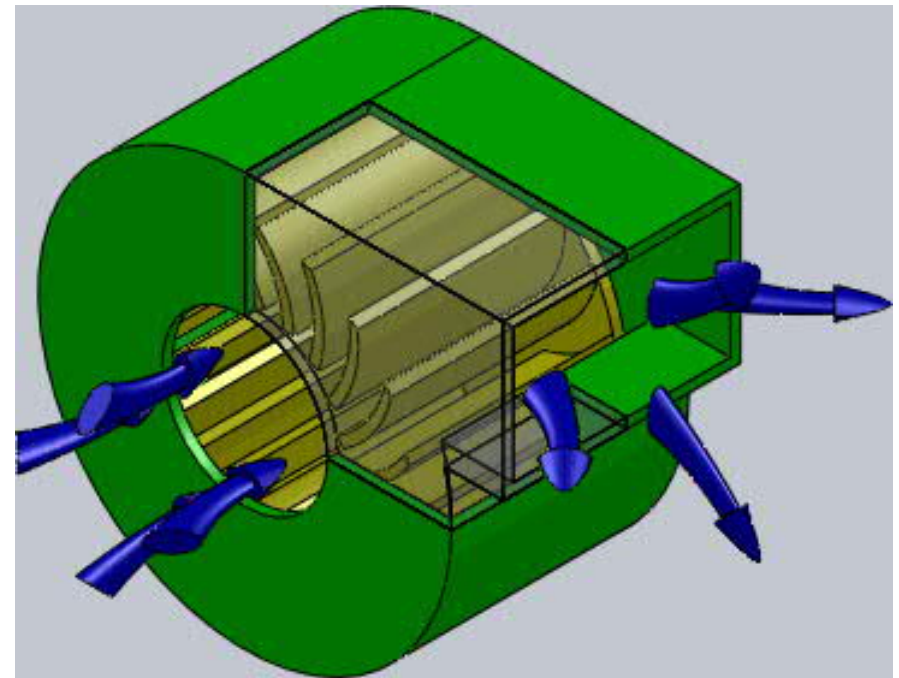

Fan Design

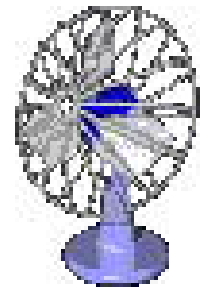

- Common types of fans
 - Centrifugal fans: radial, forward curved, air foil (backward curved), backward inclined, tubular, roof ventilator
 - Axial fans: propeller, tube-axial, vane-axial
- Fan arrangements
 - Motor location, air discharge orientation, drive train type (direct drive or pulley drive)
 - Centrifugal: single width single inlet (SWSI), double width double inlet (DWDI)

CENTRIFUGAL FANS

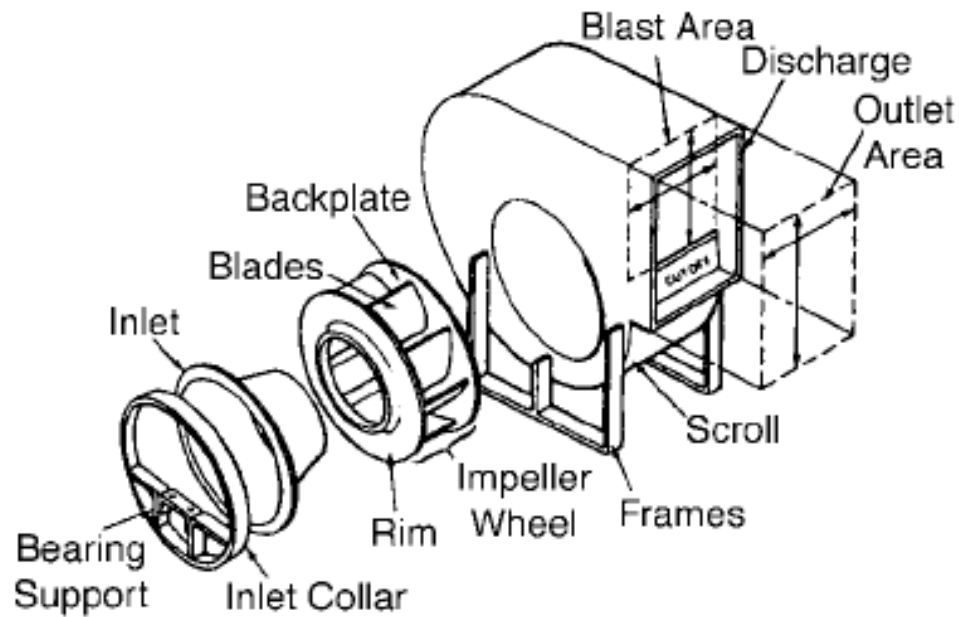

AXIAL FANS

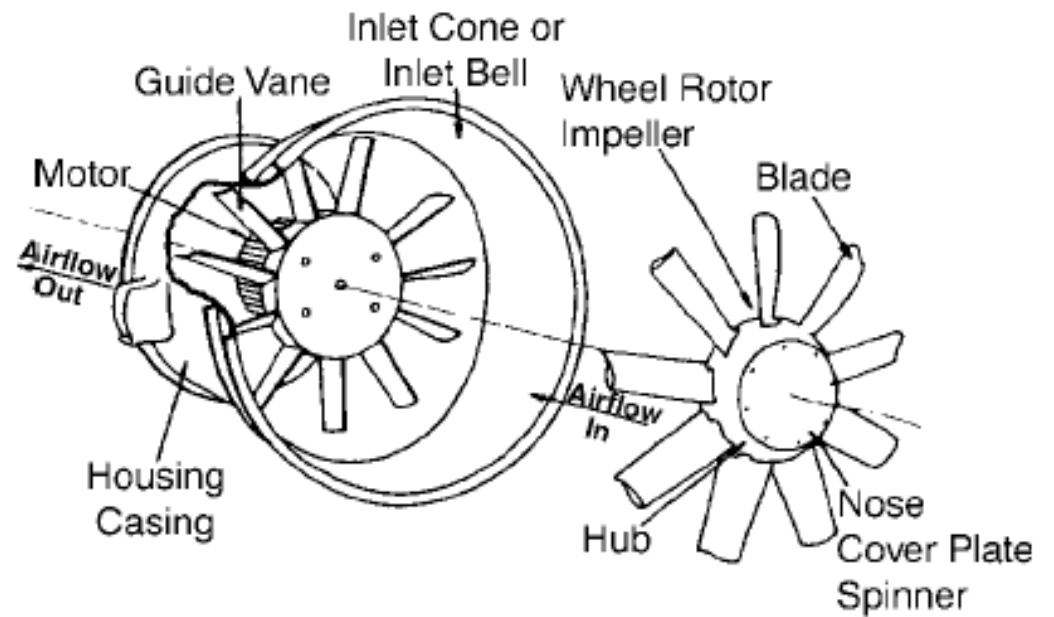

Centrifugal and axial fan components

AXIAL FANS

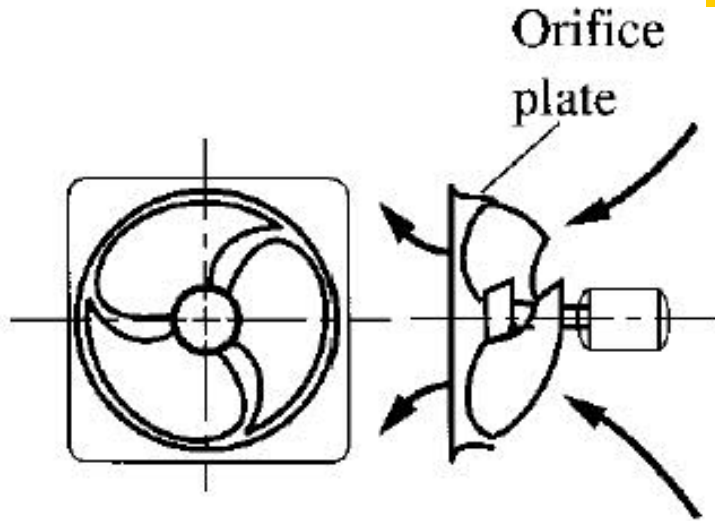

Propeller

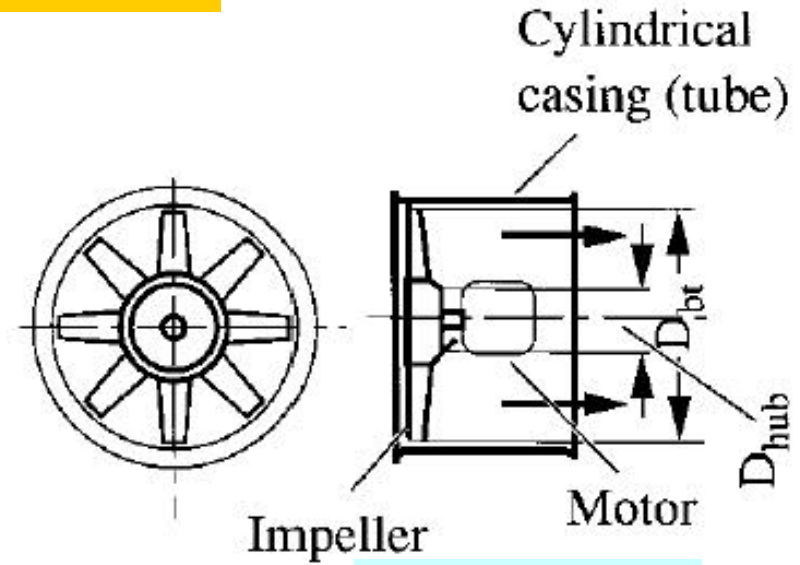

Tube-axial

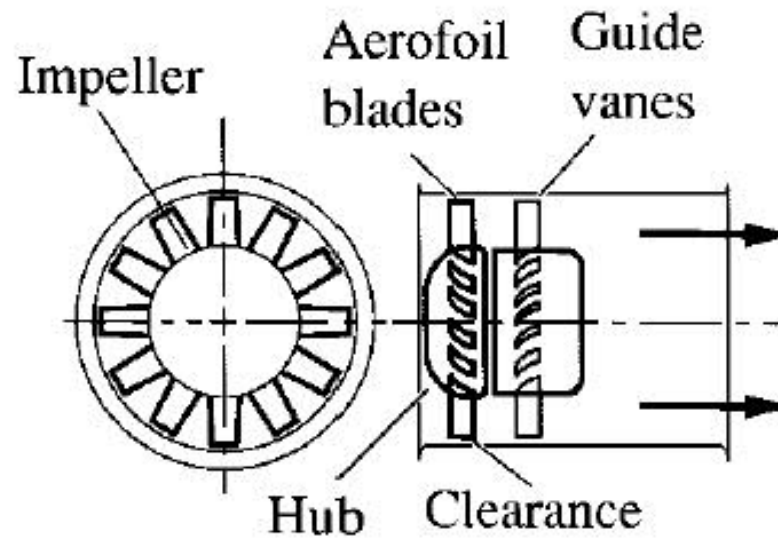

Tube-vane

CENTRIFUGAL FANS

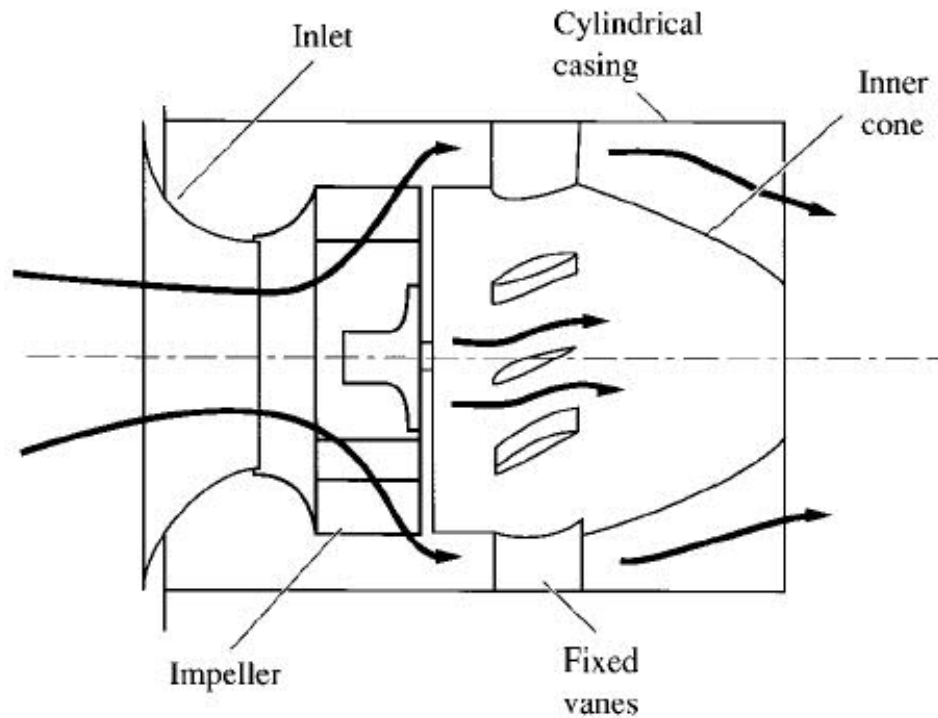

Tubular centrifugal fan

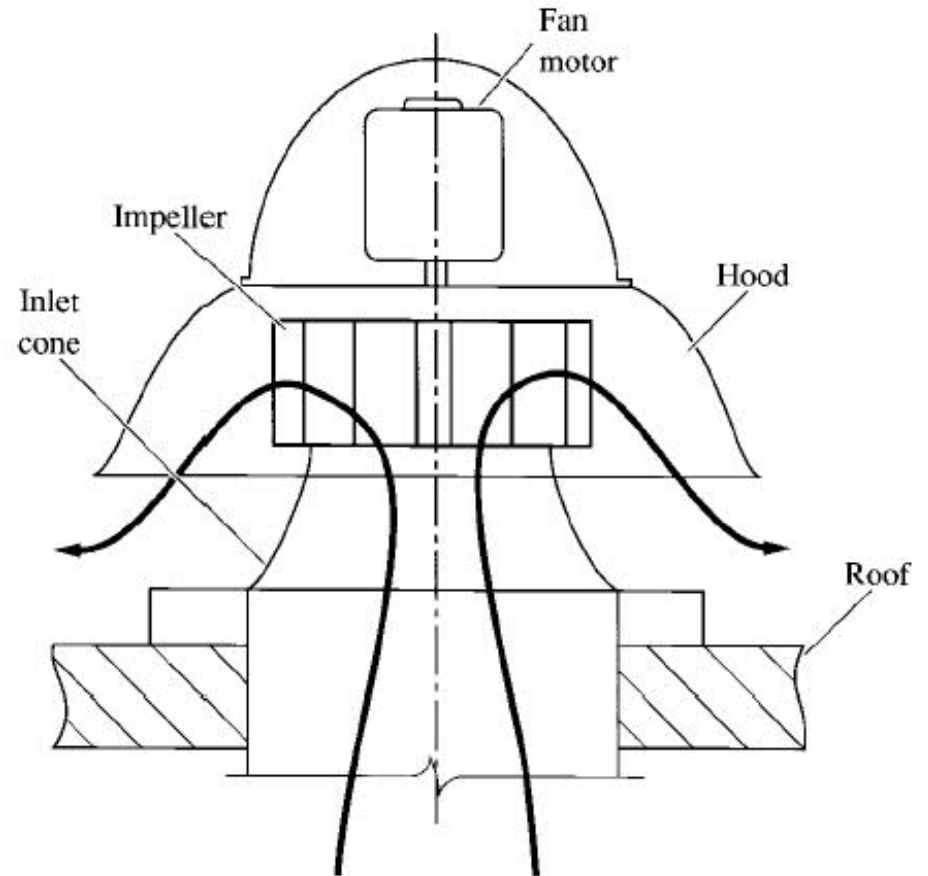

Centrifugal roof ventilator

(* Note the airflow paths and impeller design.)

(Source: Wang, S. K., 2001. Handbook of Air Conditioning and Refrigeration)

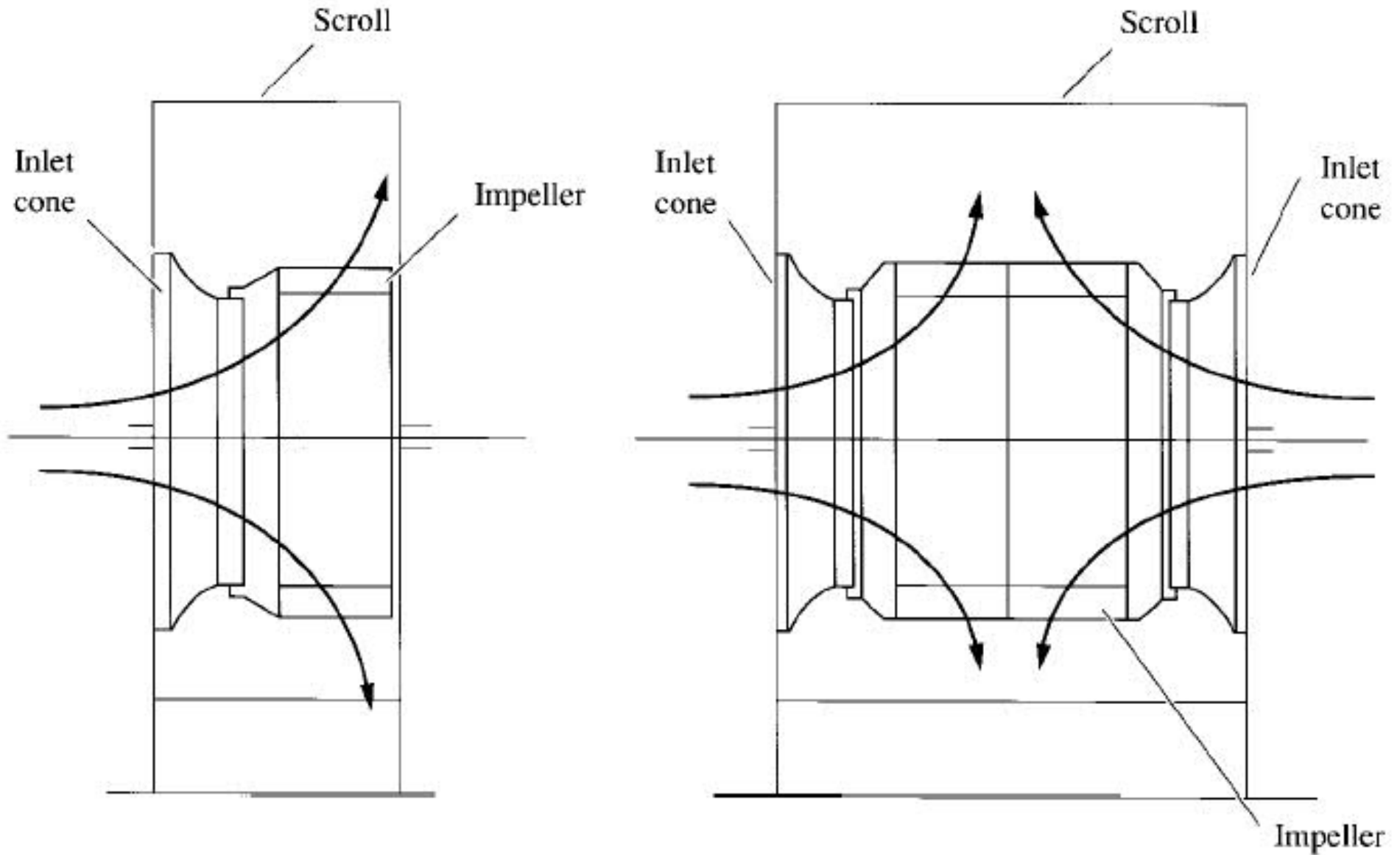

Single- and double-width centrifugal fans

(Source: Wang, S. K., 2001. *Handbook of Air Conditioning and Refrigeration*)

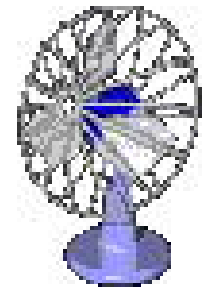

Fan Performance

- Major parameters
 - Fan volume flow rate (m^3/s or l/s), V_f
 - Fan total pressure Δp_{tf} , fan velocity pressure p_{vf} & fan static pressure Δp_{sf} (Pa)
 - Fan power & efficiency
 - Fan power or air power (W) = $\Delta p_{tf} \times V_f$
 - Fan power input on the fan shaft (brake horsepower), P_f
 - Fan total efficiency: $\eta_t = \Delta p_{tf} \times V_f / P_f$
 - Combined aerodynamic, volumetric & mechanical efficiencies
 - Fan static efficiency: $\eta_s = \Delta p_{sf} \times V_f / P_f$
 - Air temp. increase through fan, $\Delta T_f = \Delta p_{tf} / (\rho c_{pa} \eta_t)$

Fan performance curves

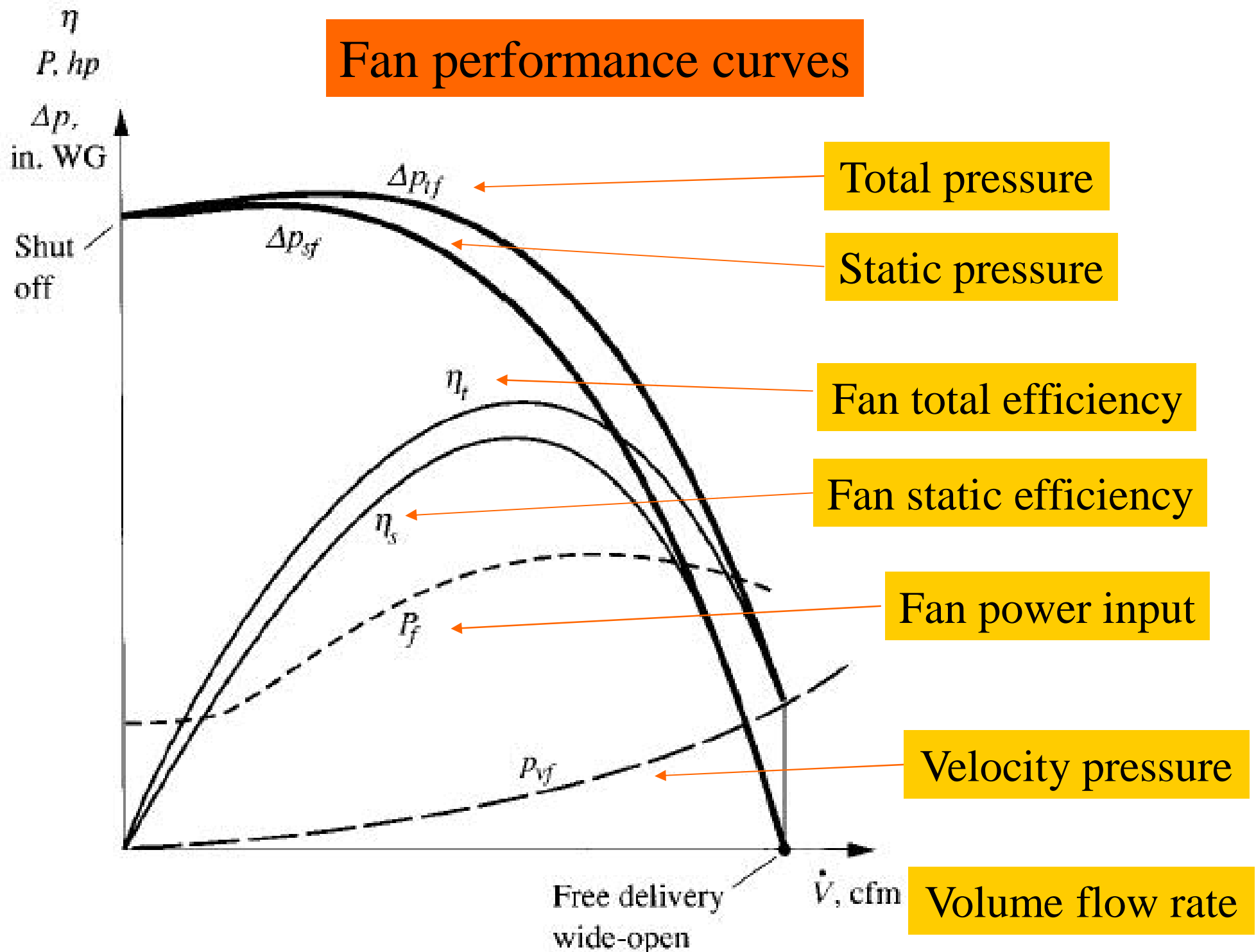

(Source: Wang, S. K., 2001. Handbook of Air Conditioning and Refrigeration)

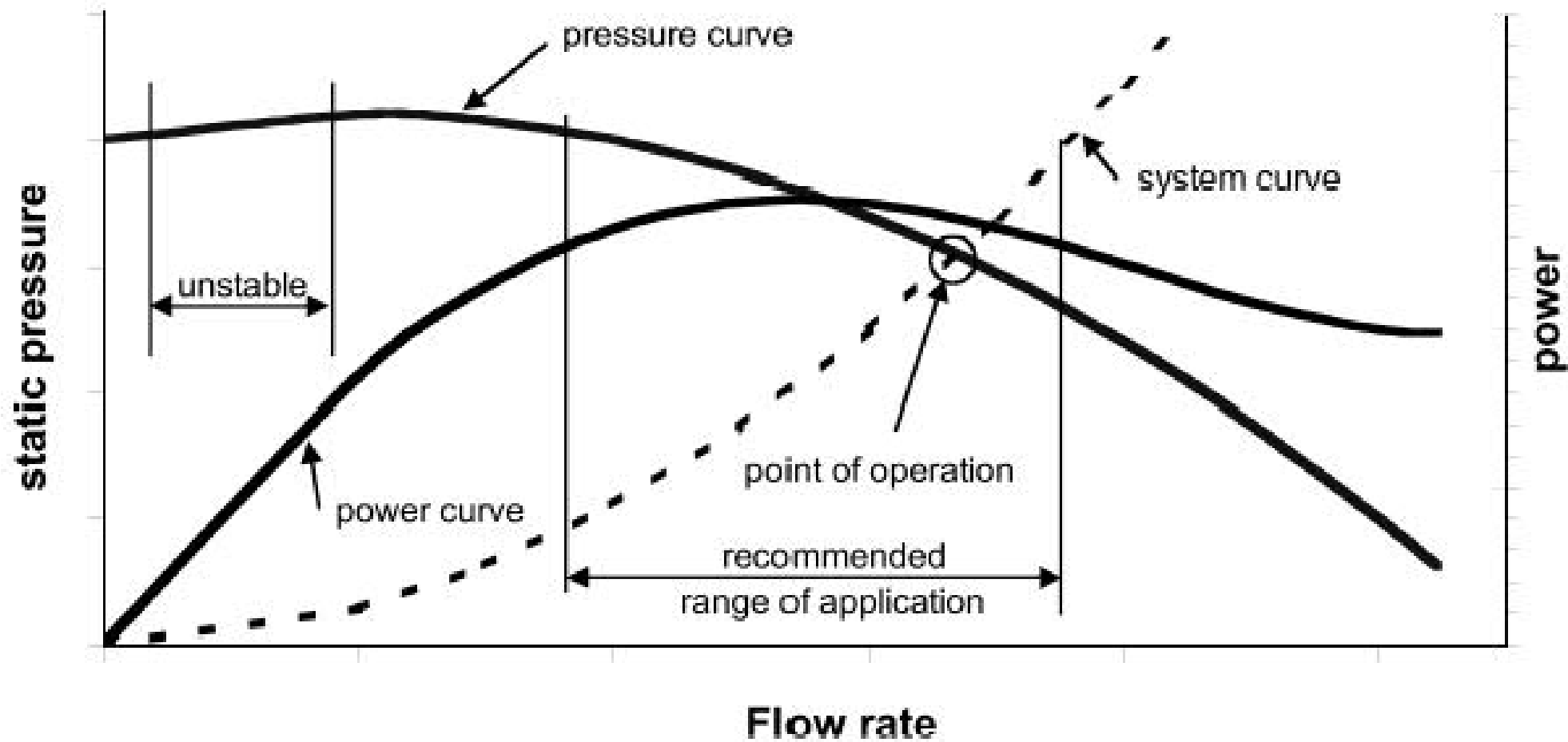

Typical fan performance curve

Fan Performance

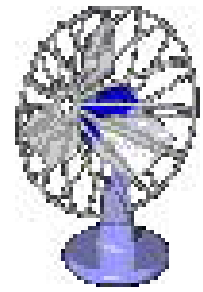

- Fan Laws

- Speed (n)
- Volume flow (V)
- Total pressure loss (Δp)
- Air density (ρ)
- For air systems that are geometrically & dynamically similar:
(D = impeller diameter)
- c.f.: pump laws

$$\dot{V}_2 / \dot{V}_1 = n_2 / n_1$$

$$\Delta p_{t2} / \Delta p_{t1} = (n_2 / n_1)^2 (\rho_2 / \rho_1)$$

$$P_2 / P_1 = (n_2 / n_1)^3 (\rho_2 / \rho_1)$$

$$\dot{V}_2 / \dot{V}_1 = (D_2 / D_1)^3 (n_2 / n_1)$$

$$\Delta p_{t2} / \Delta p_{t1} = (D_2 / D_1)^2 (n_2 / n_1)^2 (\rho_2 / \rho_1)$$

$$P_2 / P_1 = (D_2 / D_1)^5 (n_2 / n_1)^3 (\rho_2 / \rho_1)$$

CENTRIFUGAL FANS

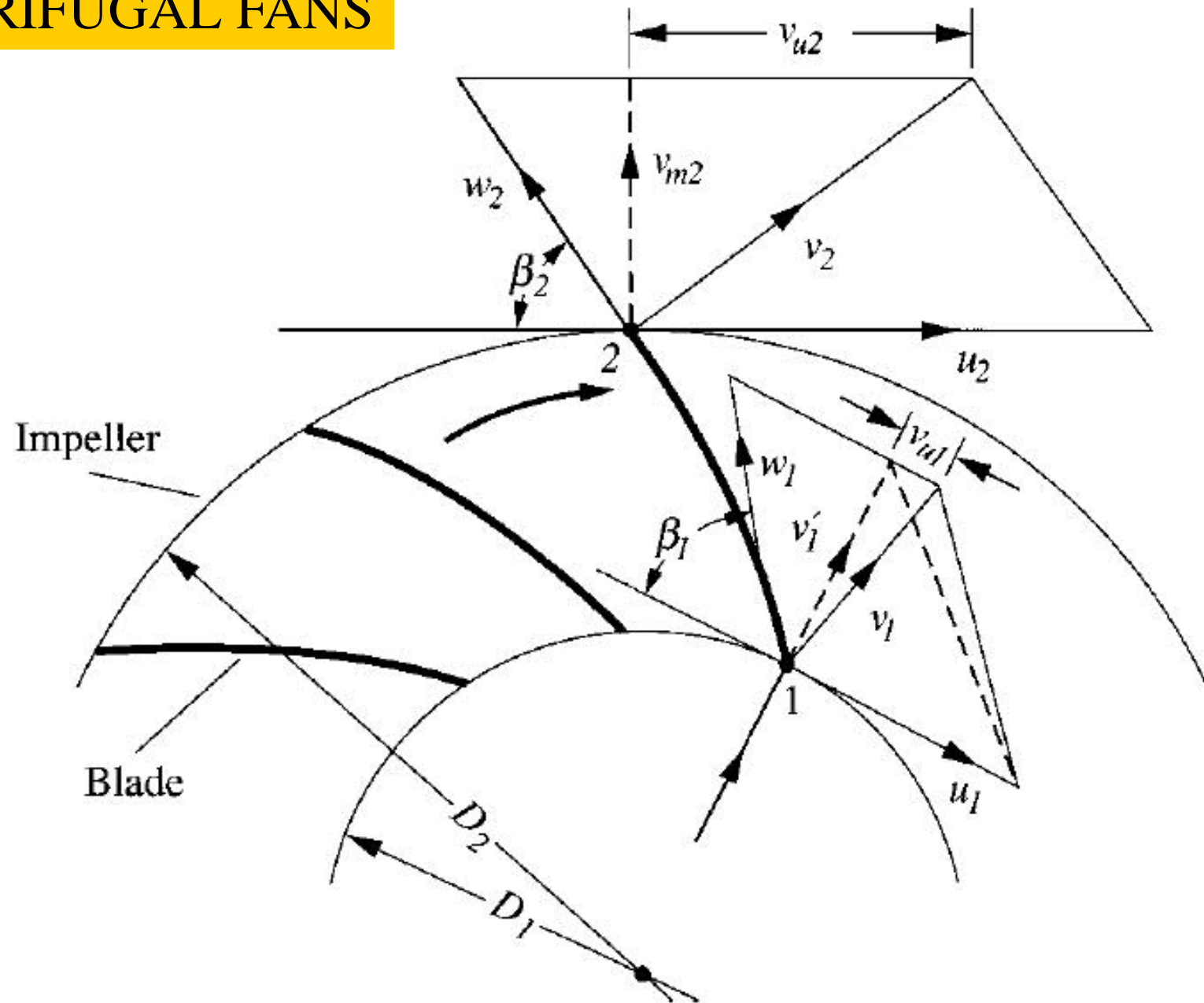

Velocity triangle at the blade inlet and outlet of a centrifugal fan

(Source: Wang, S. K., 2001. Handbook of Air Conditioning and Refrigeration)

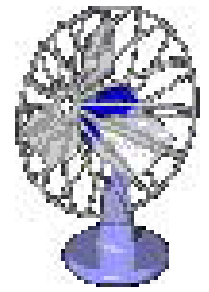

Fan Performance

- Major issues causing energy losses to a centrifugal fan:
 - Circulatory flow between the blades
 - Air leakage at the inlet
 - Friction between fluid particles and the blade
 - Energy loss at the entrance
 - Partially filled passage

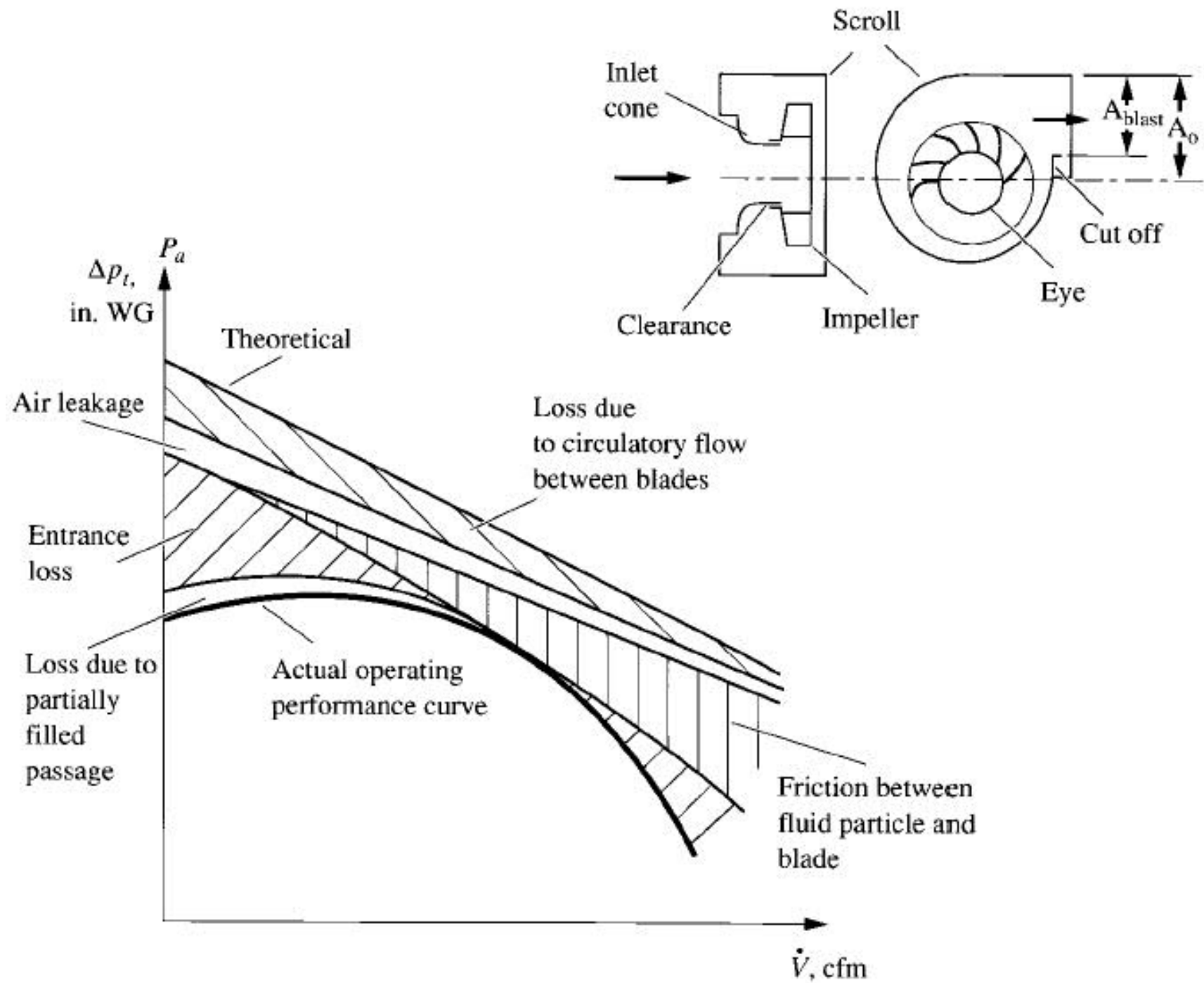

Operating characteristics for a backward-curved centrifugal fan

(Source: Wang, S. K., 2001. Handbook of Air Conditioning and Refrigeration)

Total efficiency curves for centrifugal fans

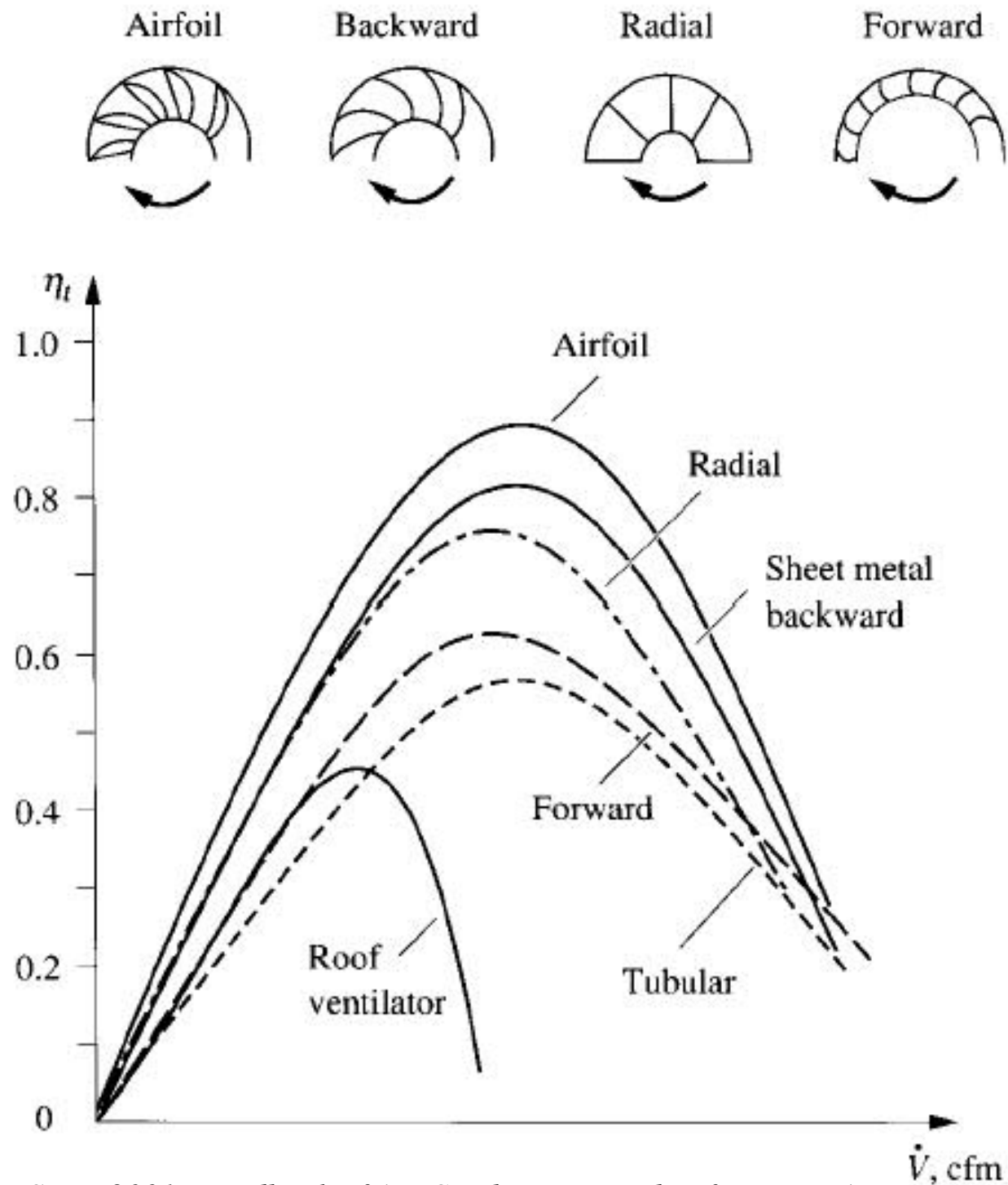

(Source: Wang, S. K., 2001. Handbook of Air Conditioning and Refrigeration)

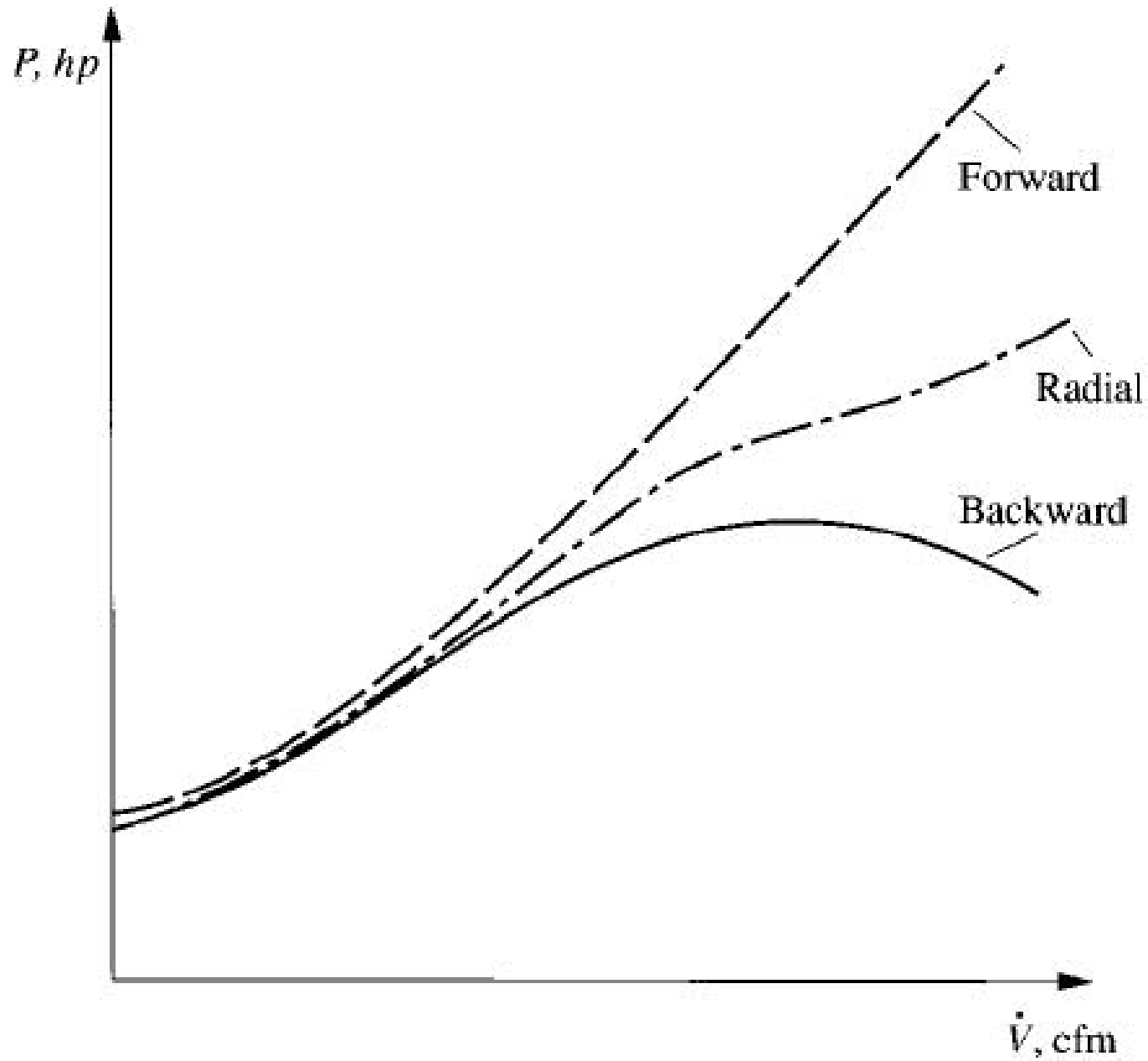

Fan power curves for centrifugal fans with same impeller diameter

(Source: Wang, S. K., 2001. *Handbook of Air Conditioning and Refrigeration*)

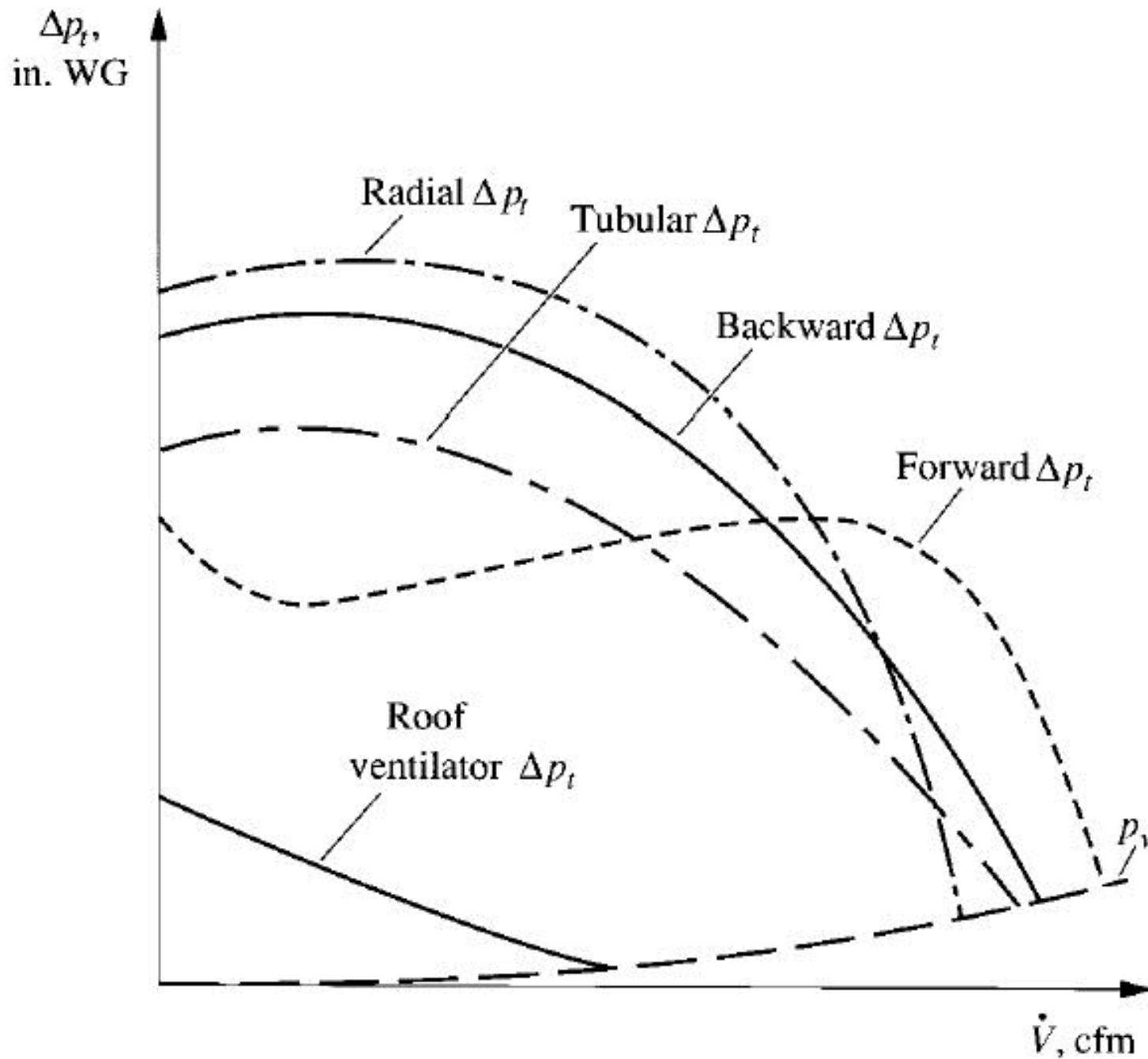

Fan pressure curves for centrifugal fans with same impeller diameter

(Source: Wang, S. K., 2001. Handbook of Air Conditioning and Refrigeration)

AXIAL FANS

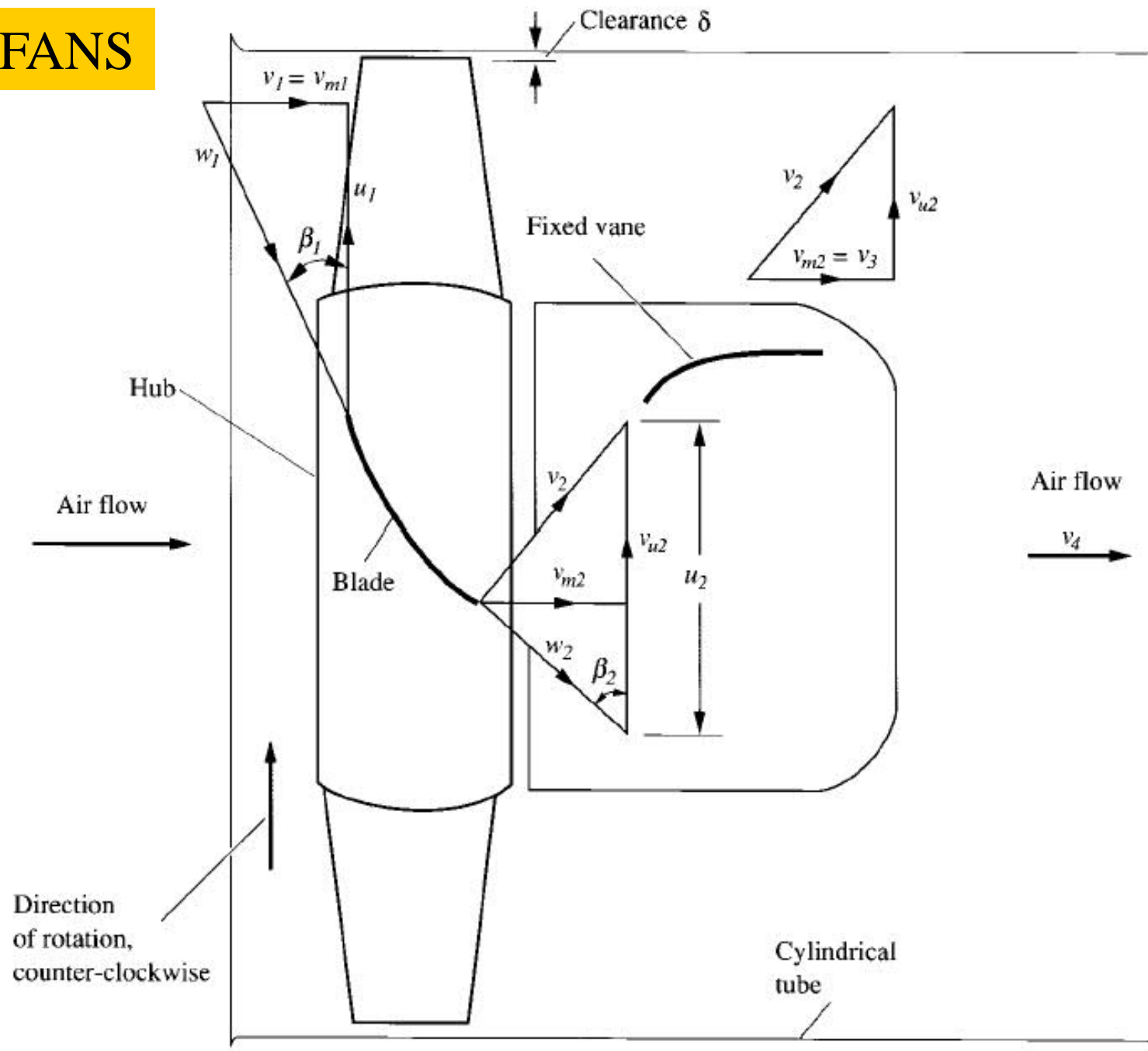

Velocity triangles for a vane-axial fan

(Source: Wang, S. K., 2001. Handbook of Air Conditioning and Refrigeration)

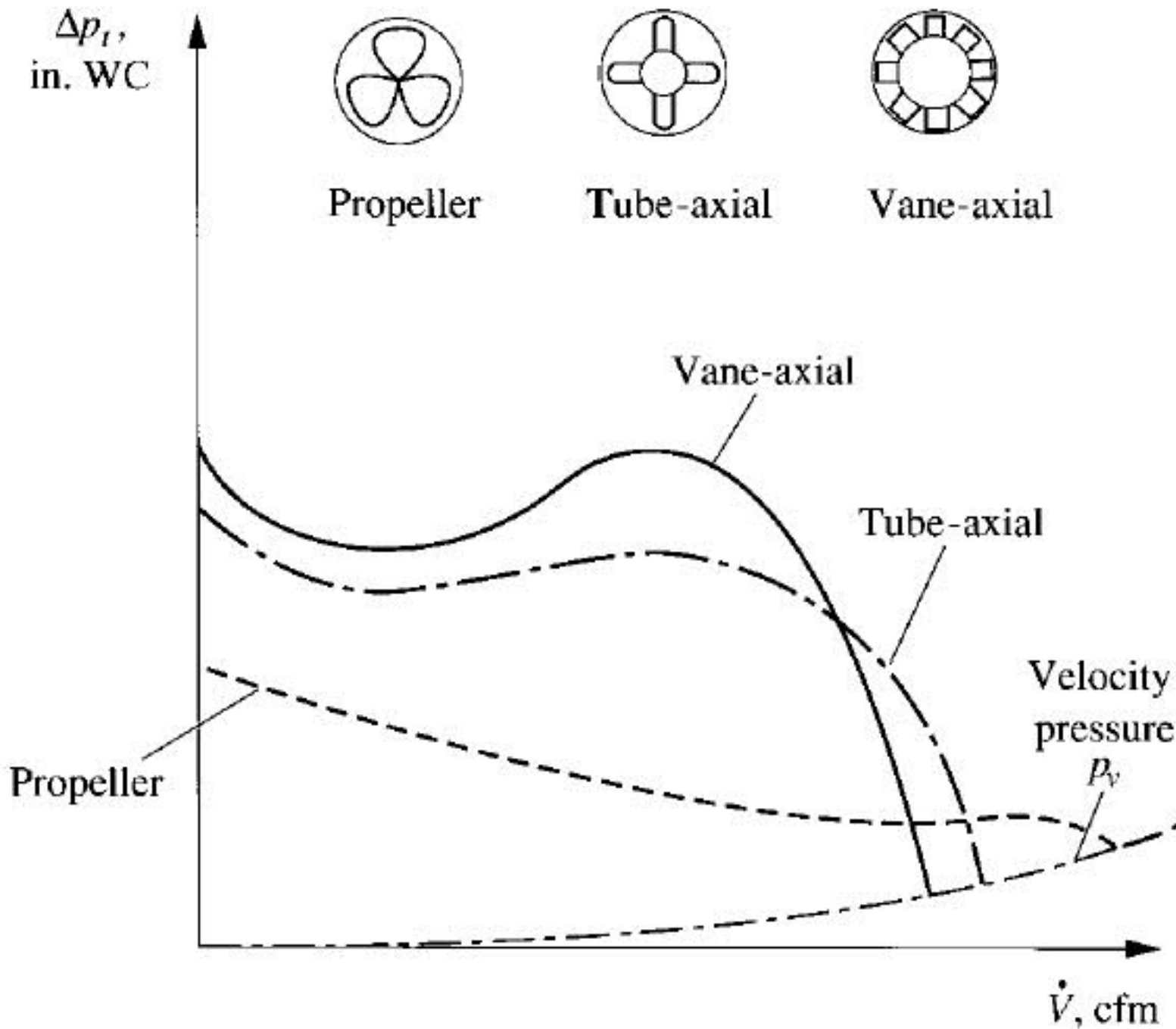

Fan pressure curves for axial fans with same impeller diameter

(Source: Wang, S. K., 2001. Handbook of Air Conditioning and Refrigeration)

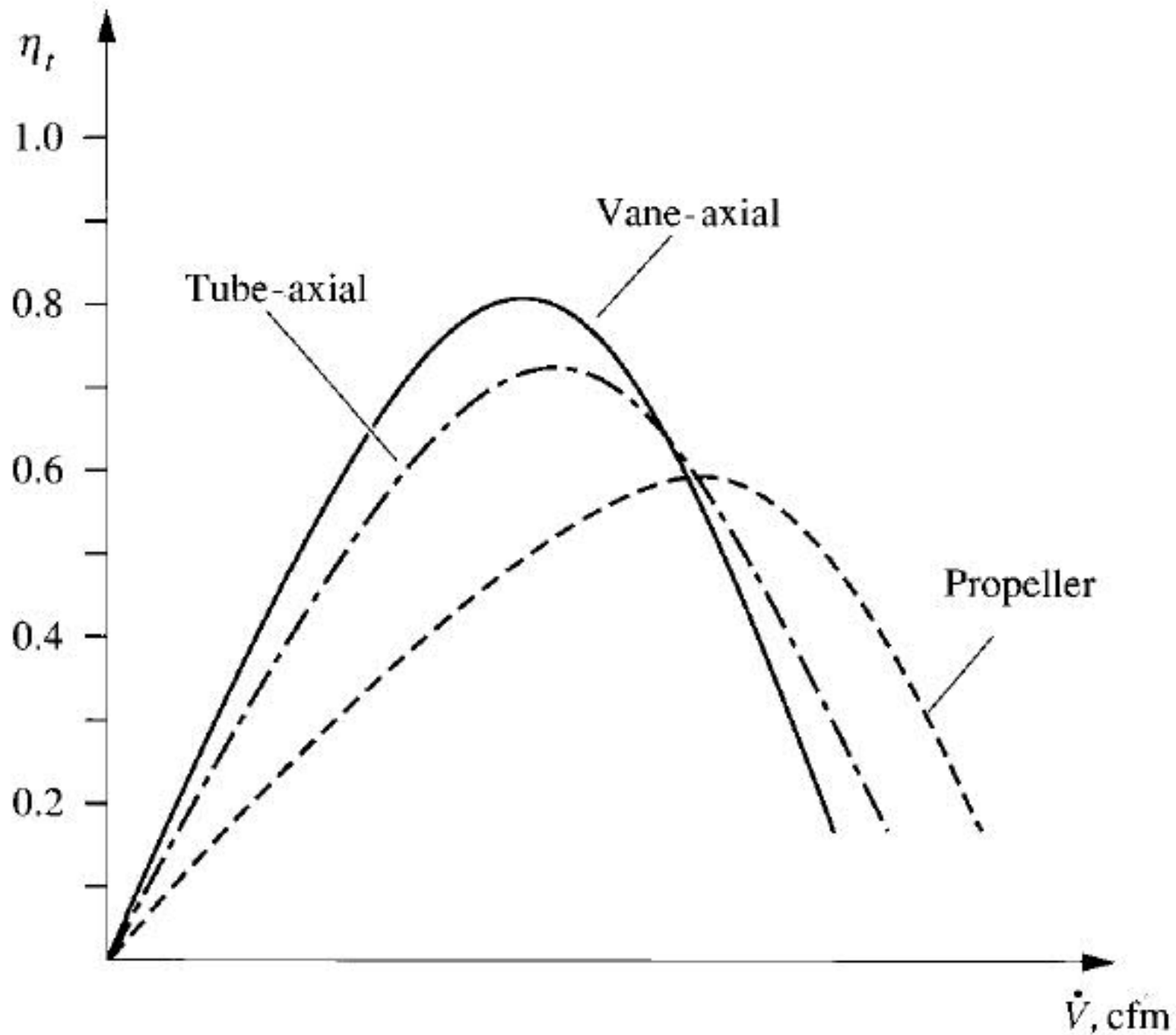

Fan efficiency curves for axial fans with same impeller diameter

(Source: Wang, S. K., 2001. Handbook of Air Conditioning and Refrigeration)

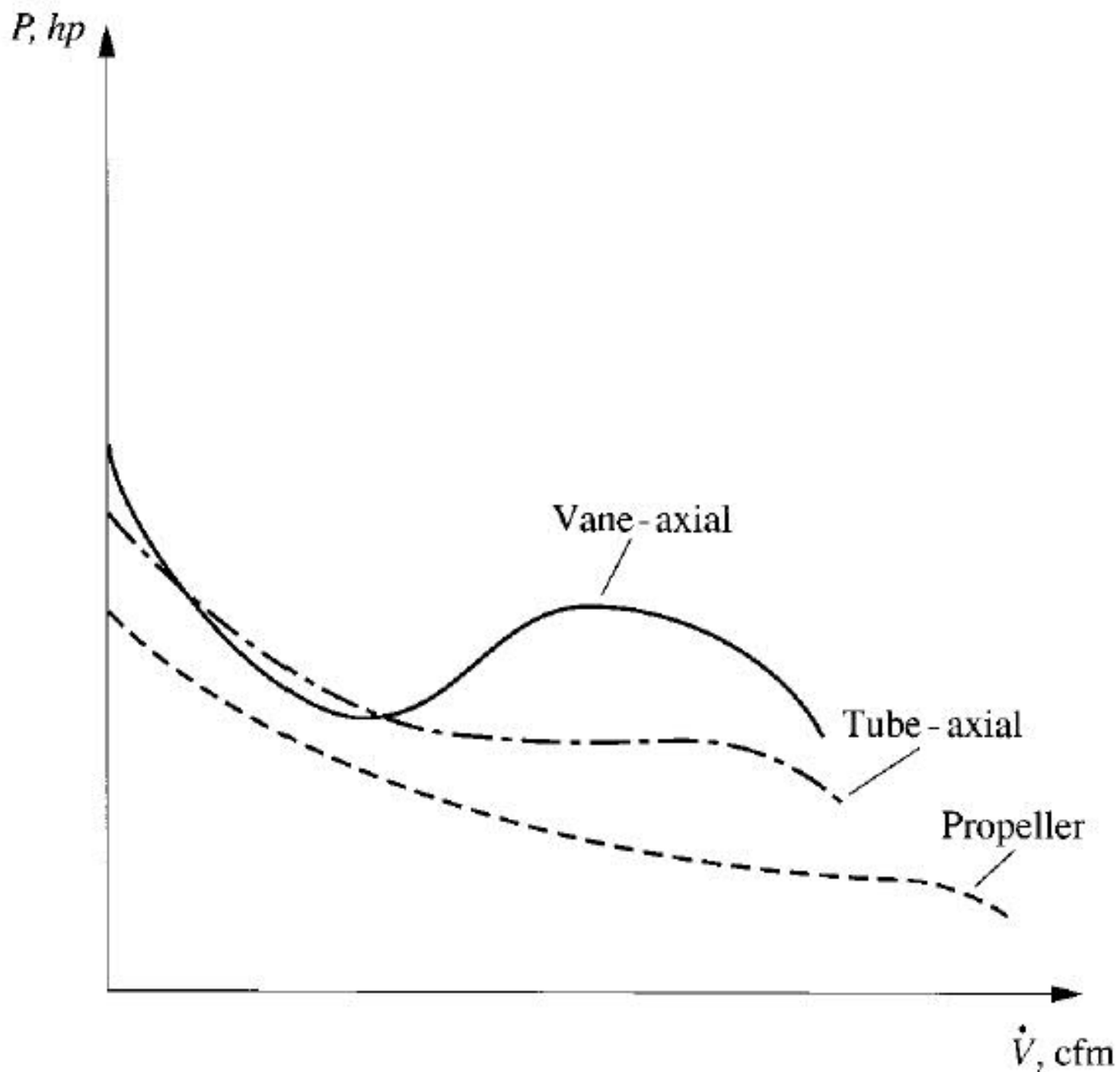

Fan power curves for axial fans with same impeller diameter

(Source: Wang, S. K., 2001. *Handbook of Air Conditioning and Refrigeration*)

Performance curves for controllable-pitch vane-axial fans

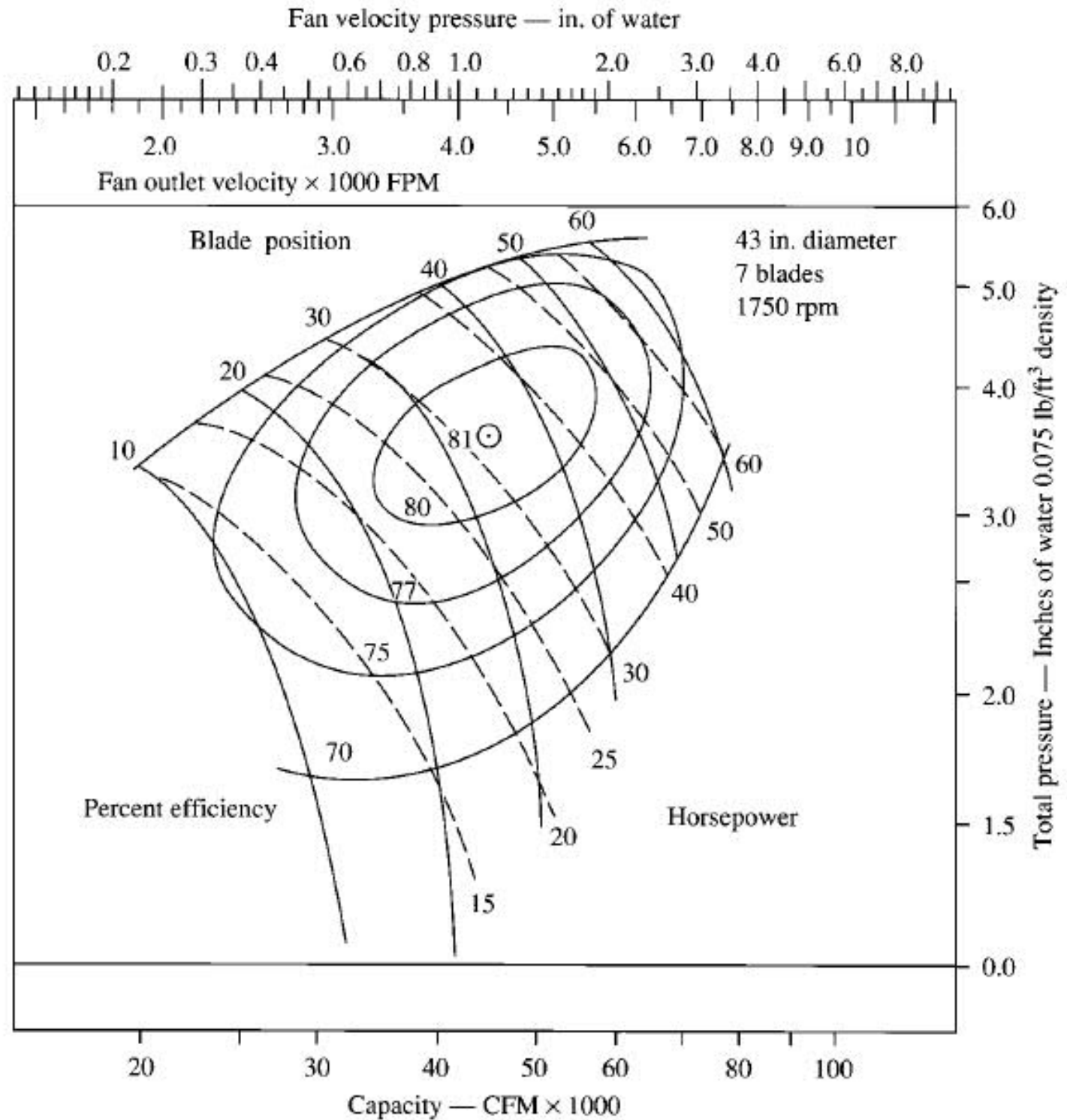

(Source: Wang, S. K., 2001. Handbook of Air Conditioning and Refrigeration)



Fan-duct Systems

- Duct pressure changes (c.f. atm pressure)
 - Static pressure (SP)
 - Velocity pressure (VP) = $\rho V^2 / 2 g$
 - Total pressure (TP) = SP + VP
- Fan: a pumping device
 - Fan (total) pressure = pressure difference between fan inlet and fan discharge
 - At fan suction/inlet, SP = negative (c.f. atmospheric); at discharge, SP = positive

STATIC AND TOTAL PRESSURE

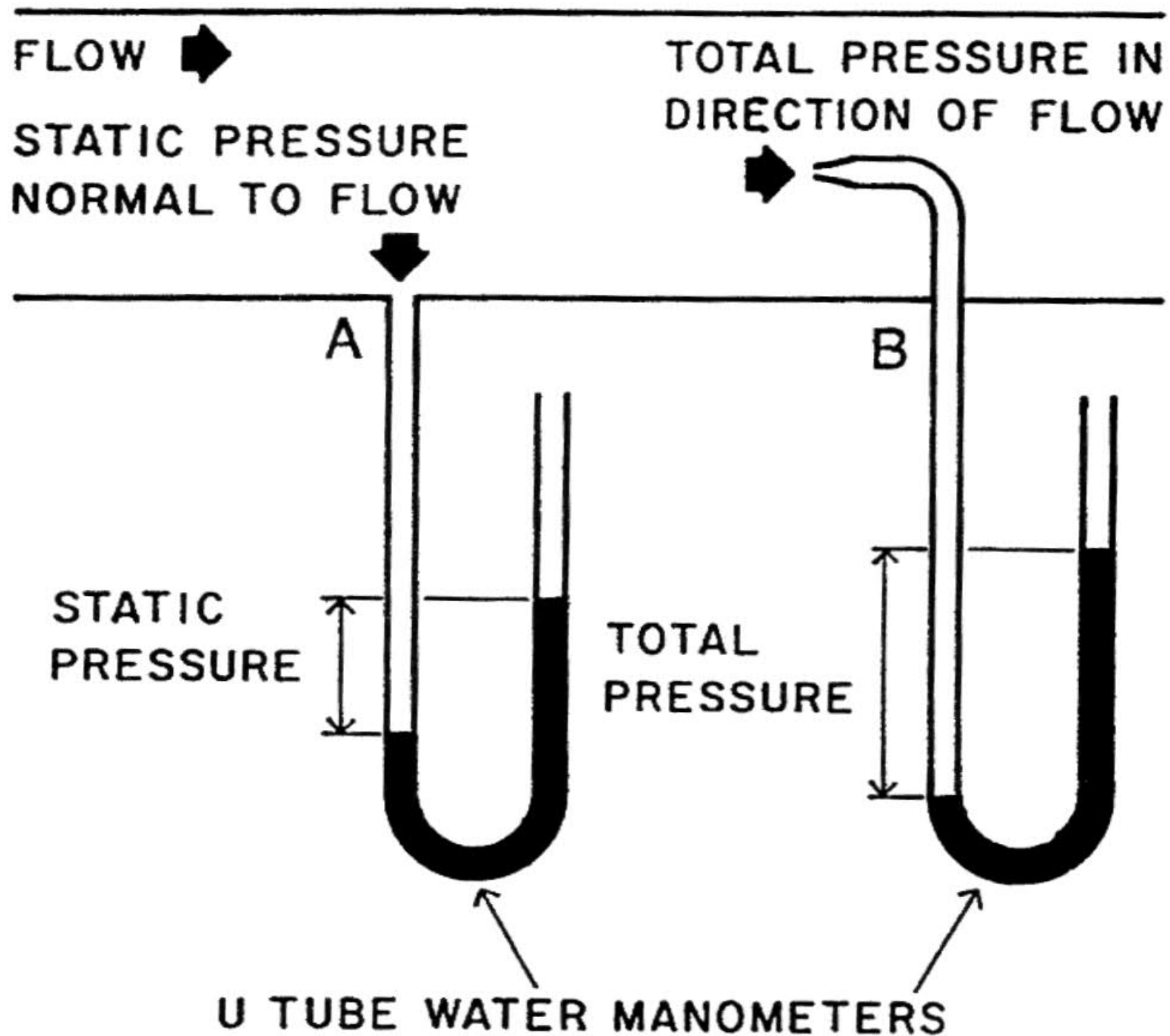

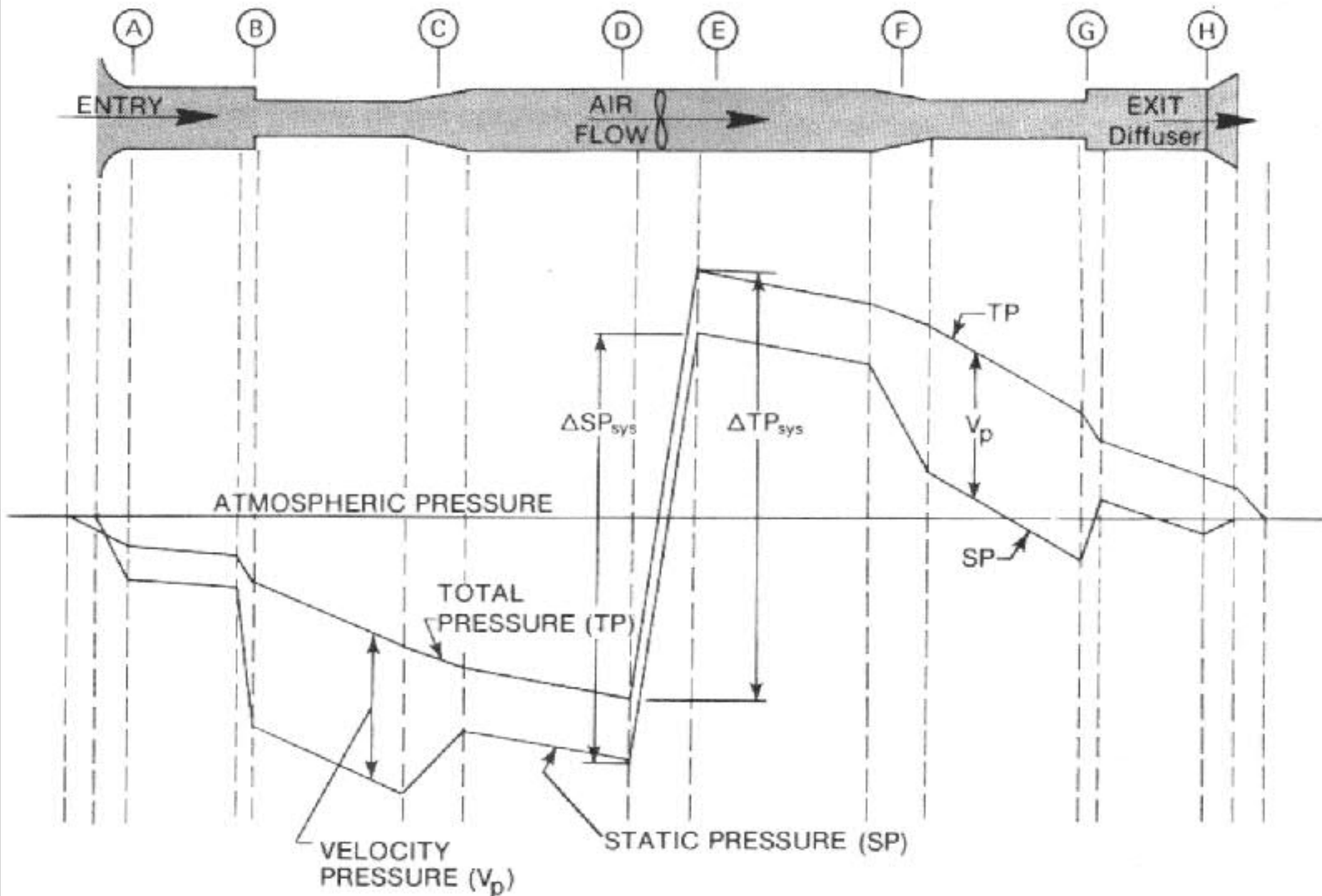

Fan-duct Systems



- Pressure characteristics
 - SP and VP are mutually convertible (\uparrow or \downarrow)
 - TP always decreases in the direction of airflow
 - For constant-area straight duct sections
 - Velocity and VP are constant
 - TP change = SP change
 - When duct cross-sectional areas are reduced
 - Velocity and VP increase
 - Absolute value of both TP and SP decrease
 - Dynamic losses from elbow, dampers, etc.

Fan-duct Systems

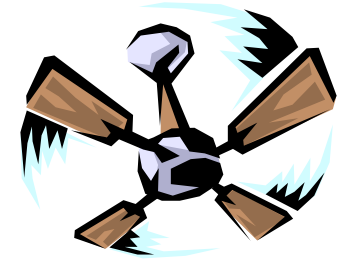

- Fan-duct systems
 - Flow resistance R , pressure drop Δp and volume flow rate V

$$\Delta p = R \cdot \dot{V}^2$$

- Duct sections in series: $R_s = R_1 + R_2 + \dots + R_n$
- Duct sections in parallel:

$$\frac{1}{\sqrt{R_p}} = \frac{1}{\sqrt{R_1}} + \frac{1}{\sqrt{R_2}} + \dots + \frac{1}{\sqrt{R_n}}$$

Fan-duct Systems

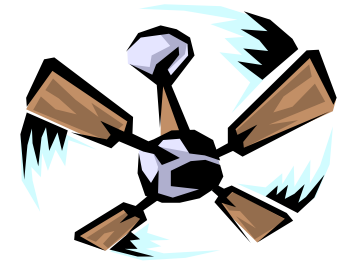

- Fan-duct systems
 - Terminology
 - Primary air (conditioned air or makeup air)
 - Secondary air (induced space air, plenum air, or recirculating air)
 - Transfer air (indoor air that moves from an adjacent area)
 - System curve: volume flow vs pressure loss
 - System operating point

Fan-duct Systems

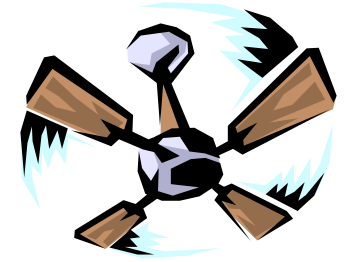

- System effect Δp_{ts}
 - Its additional total pressure loss caused by uneven or non-uniform velocity profile at the fan inlet, or at duct fittings after fan outlet
 - Due to the actual inlet and outlet connections as compared with the total pressure loss of the fan test unit during laboratory ratings

$$\begin{aligned}\Delta p_{ts} &= \Delta p_{sy} + \Delta p_{se} = \Delta p_{sy} + \Delta p_{s.i} + \Delta p_{s.o} \\ &= \Delta p_{sy} + C_{s.i} \left(v_{fi} / 4005 \right)^2 + C_{s.o} \left(v_{fo} / 4005 \right)^2\end{aligned}$$

Inlet **Outlet**

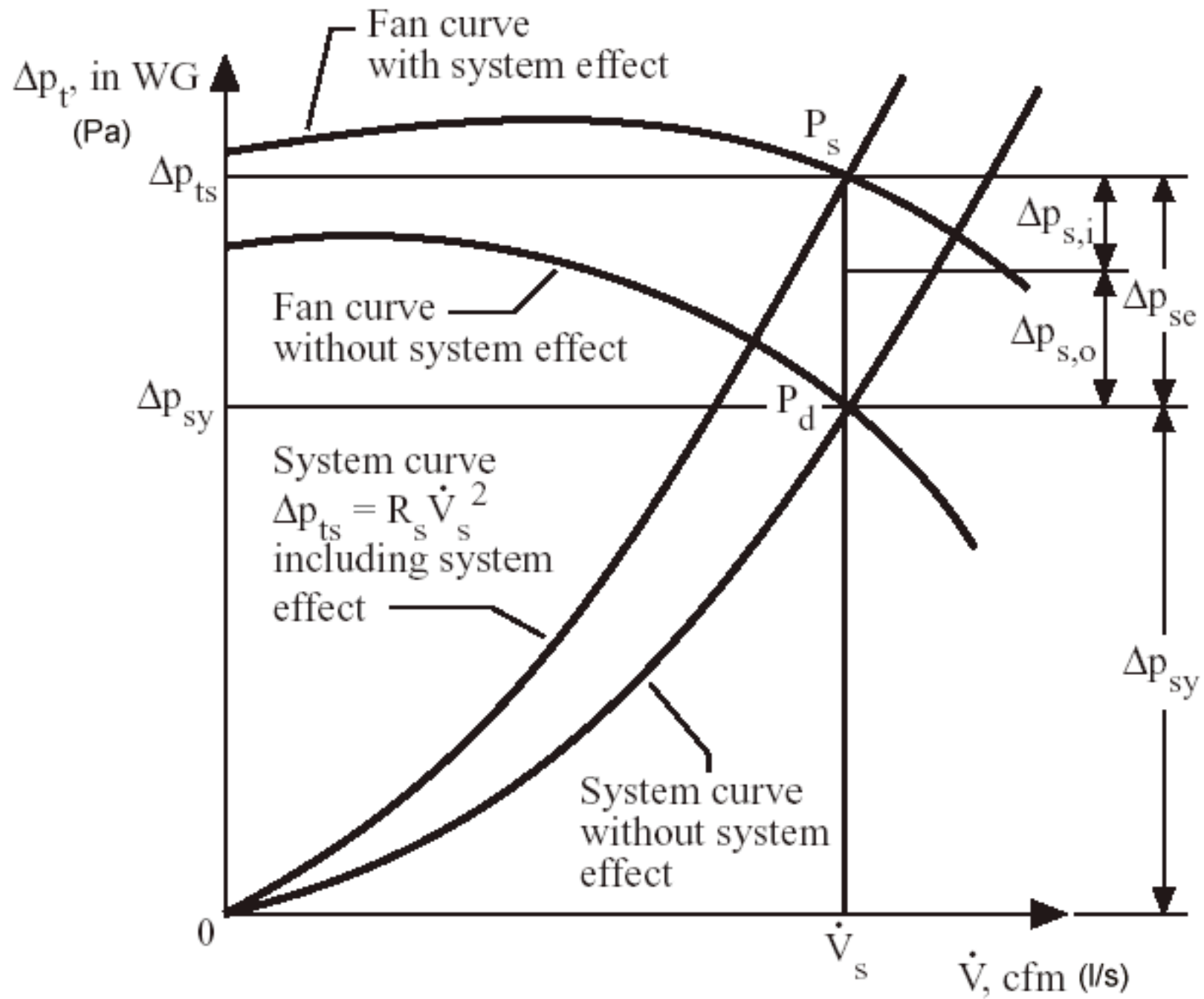

Fan system operating point & system effect

(Source: Wang, S. K., 2001. Handbook of Air Conditioning and Refrigeration)

Fan-duct Systems

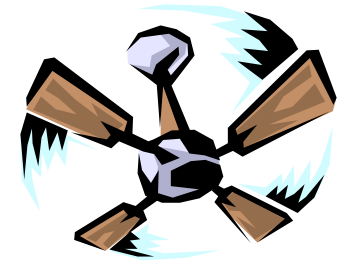

- Modulation of air systems
 - Constant volume system
 - Volume flow rate remains constant
 - Supply temperature is raised during part load
 - Variable-air-volume (VAV) system
 - Volume flow rate is reduced to match part load operation
 - Modulation curve

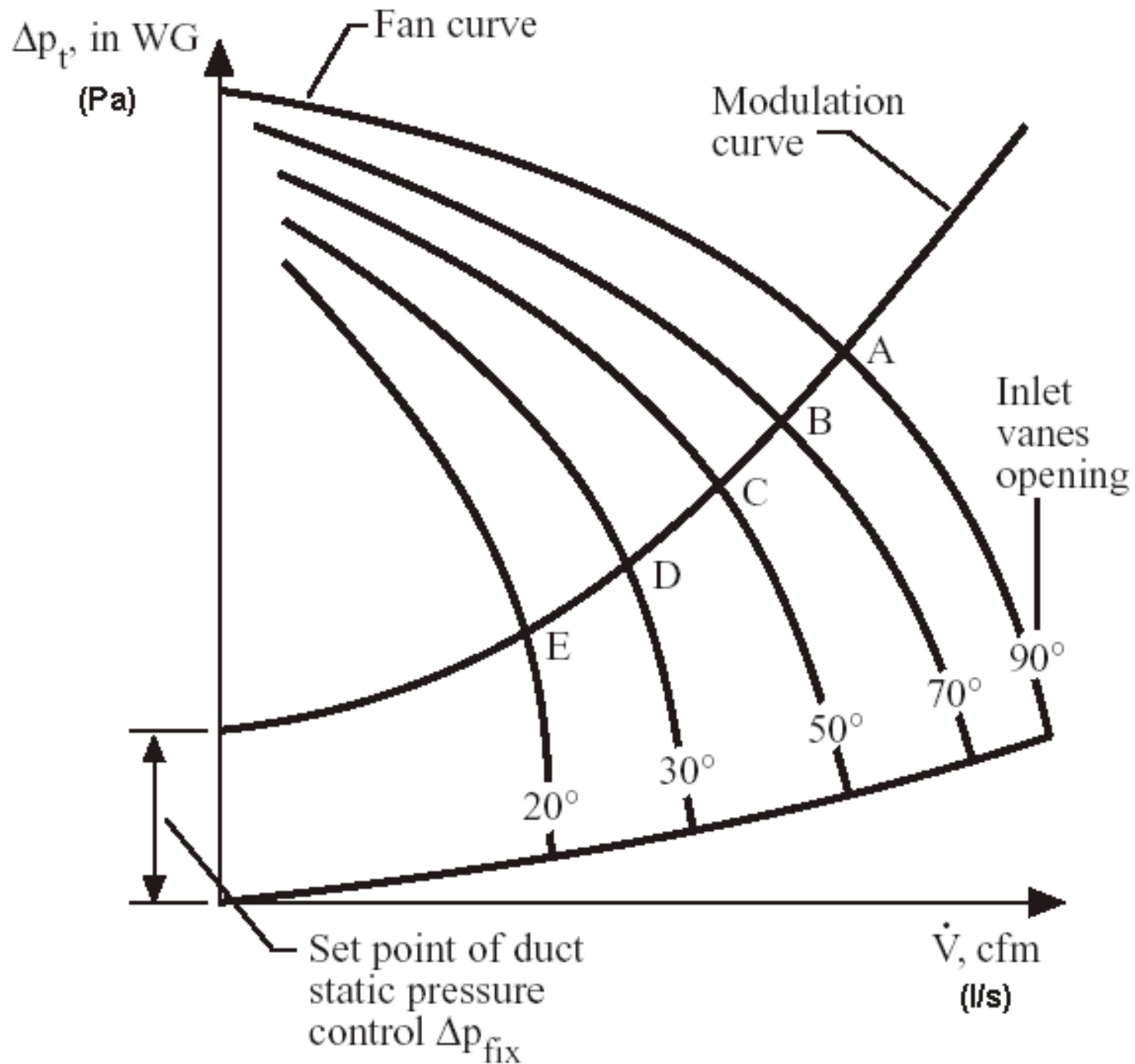

Fan modulation curve

(Source: Wang, S. K., 2001. Handbook of Air Conditioning and Refrigeration)

Fan-duct Systems

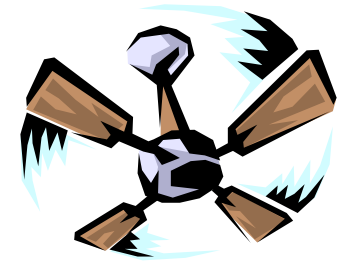

- Fan modulation methods
 - **Damper** (vary the opening of the air flow passage)
 - Waste energy
 - **Inlet vanes** (opening & angle of inlet vanes)
 - Low cost; less efficient than following types
 - **Inlet cone** (peripheral area of fan impeller)
 - Inexpensive; for backward curved centrifugal fan
 - **Blade pitch** (blade angle of axial fan)
 - **Fan speed** (using adjustable frequency drives)
 - Most energy-efficient; but usually cost more

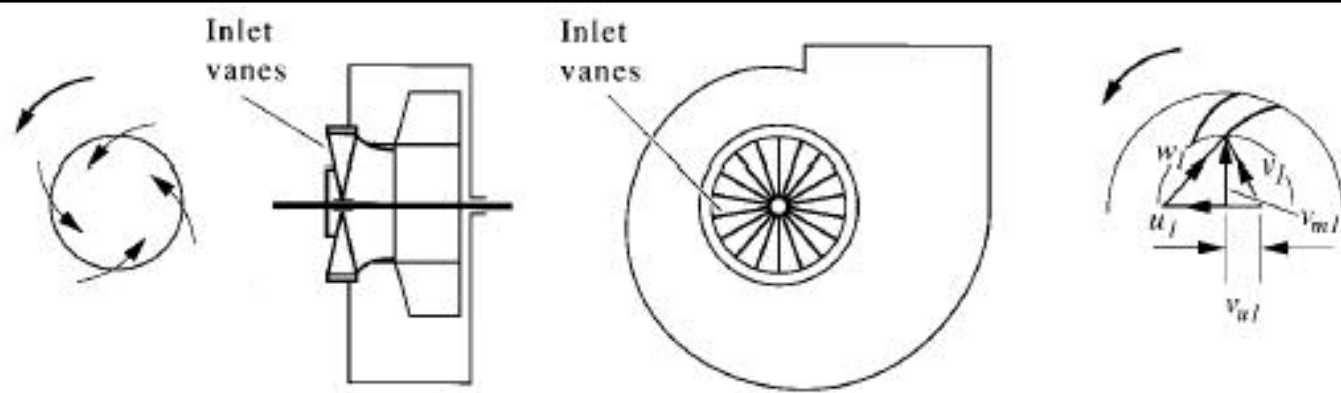

Inlet vane modulation

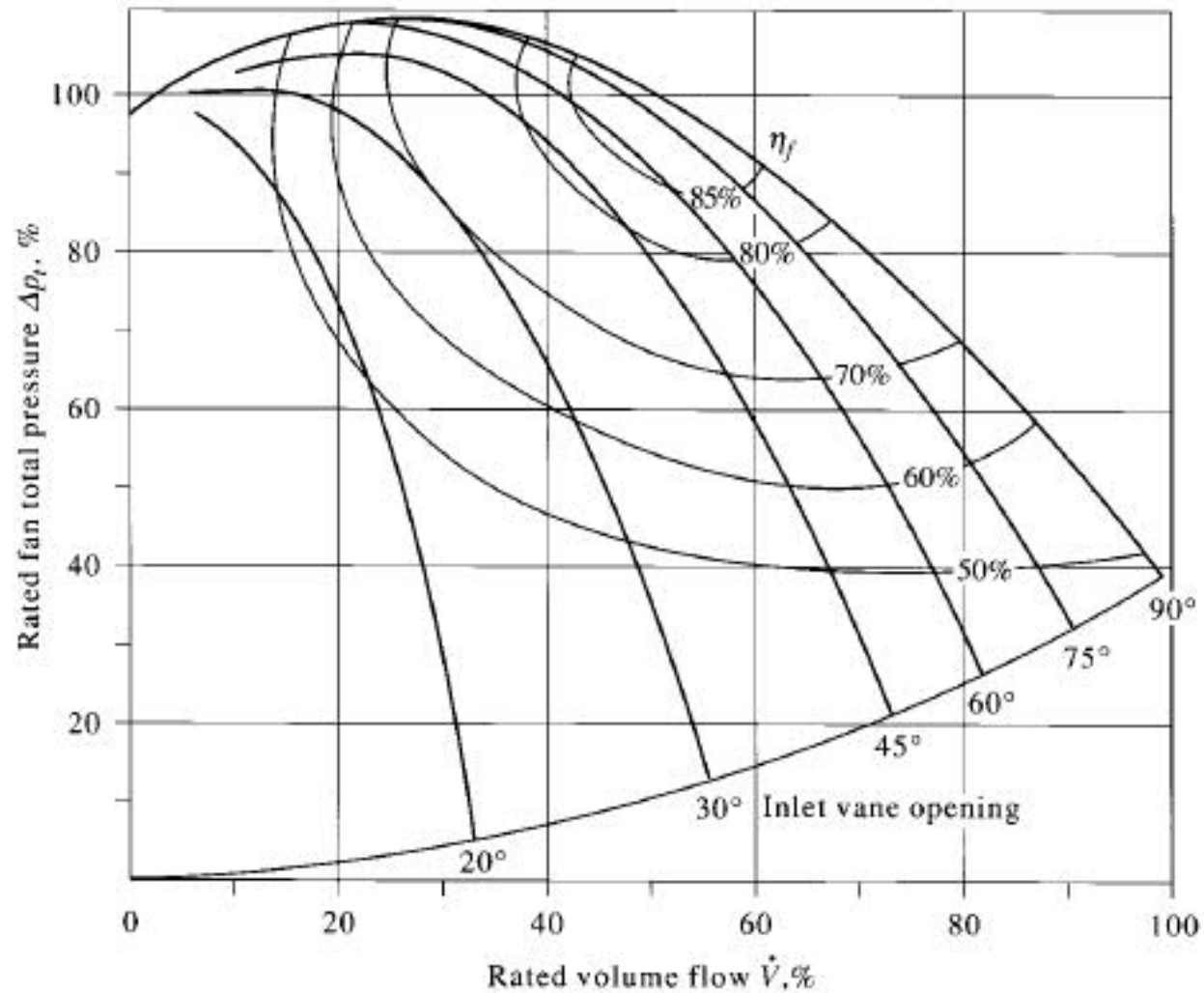

(Source: Wang, S. K., 2001. Handbook of Air Conditioning and Refrigeration)

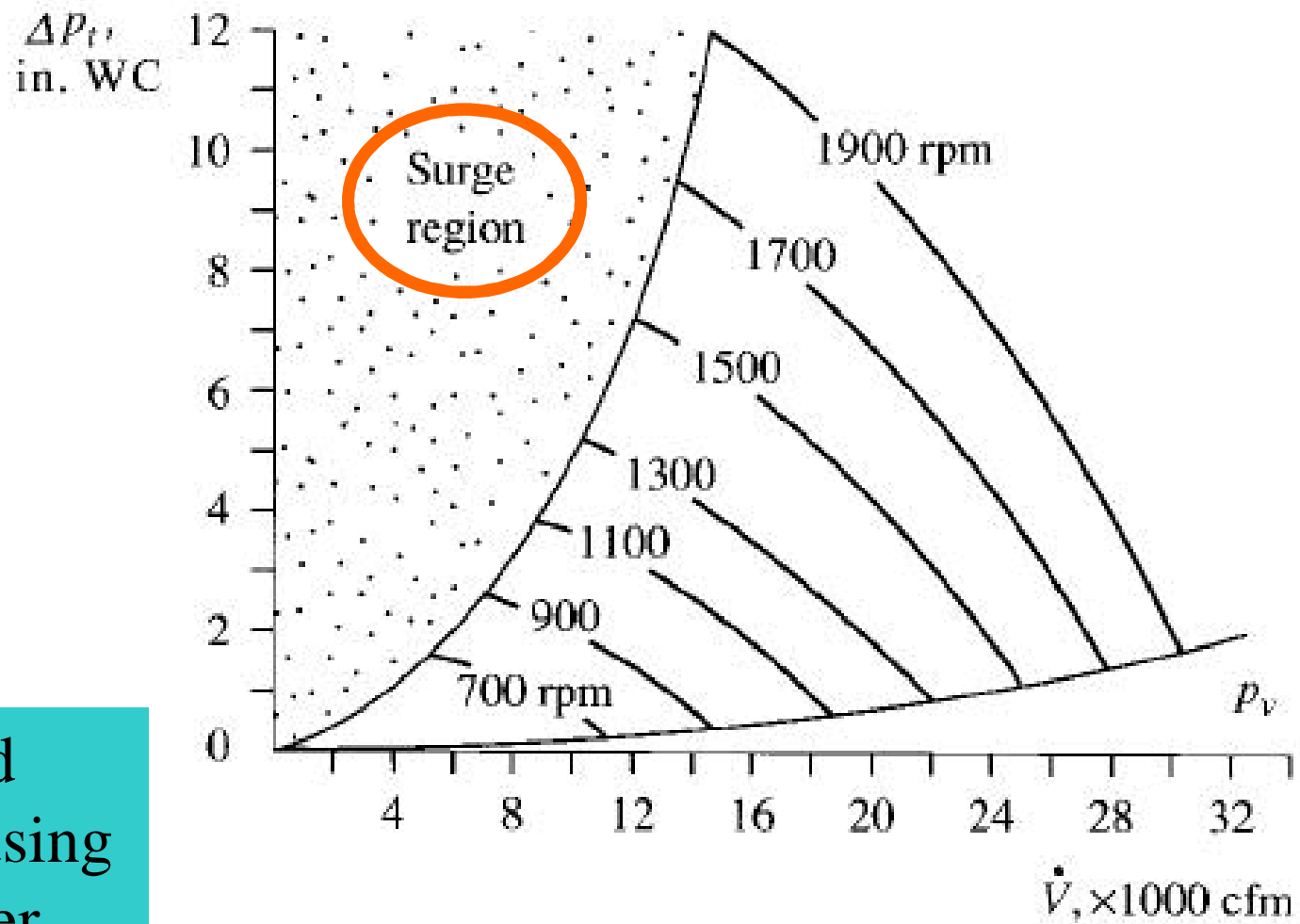

Fan speed modulation using AC inverter

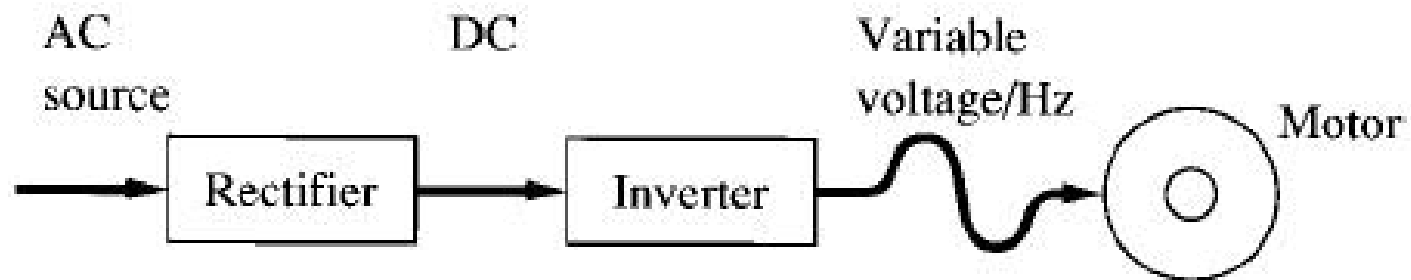

(Source: Wang, S. K., 2001. Handbook of Air Conditioning and Refrigeration)

Fan-duct Systems

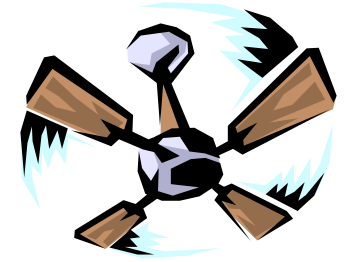

- **Fan surge** (in centrifugal fan)
 - Occurs when air volume flow is not sufficient to sustain the static pressure difference between discharge & suction
 - Discharge pressure is reduced momentarily
 - Volume flow & pressure fluctuations
 - Create noise & vibration
 - Surge region: shall avoid operation in it
- **Fan stall** (in axial fans)
 - When smooth air flow suddenly breaks & pressure difference across the blades decreases
 - The fan loses pressure capability drastically

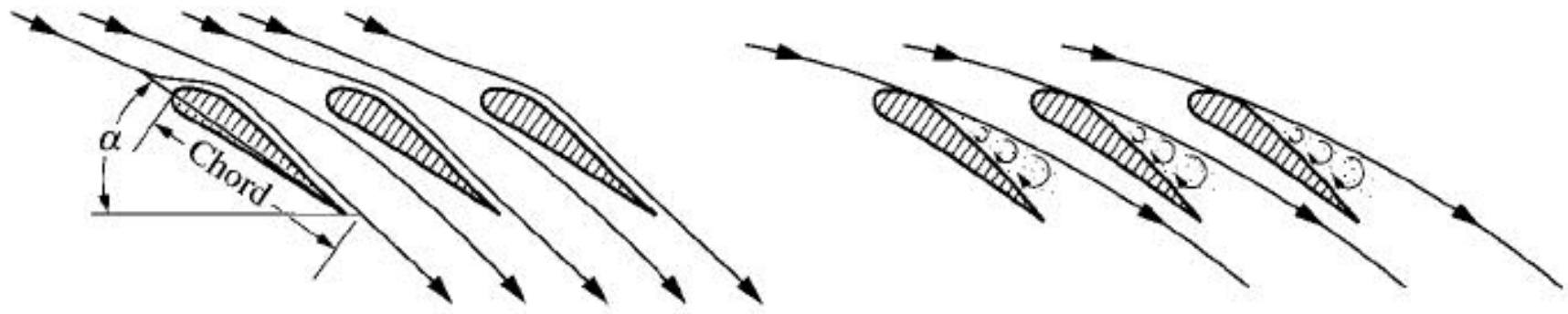

Normal operation

Stall

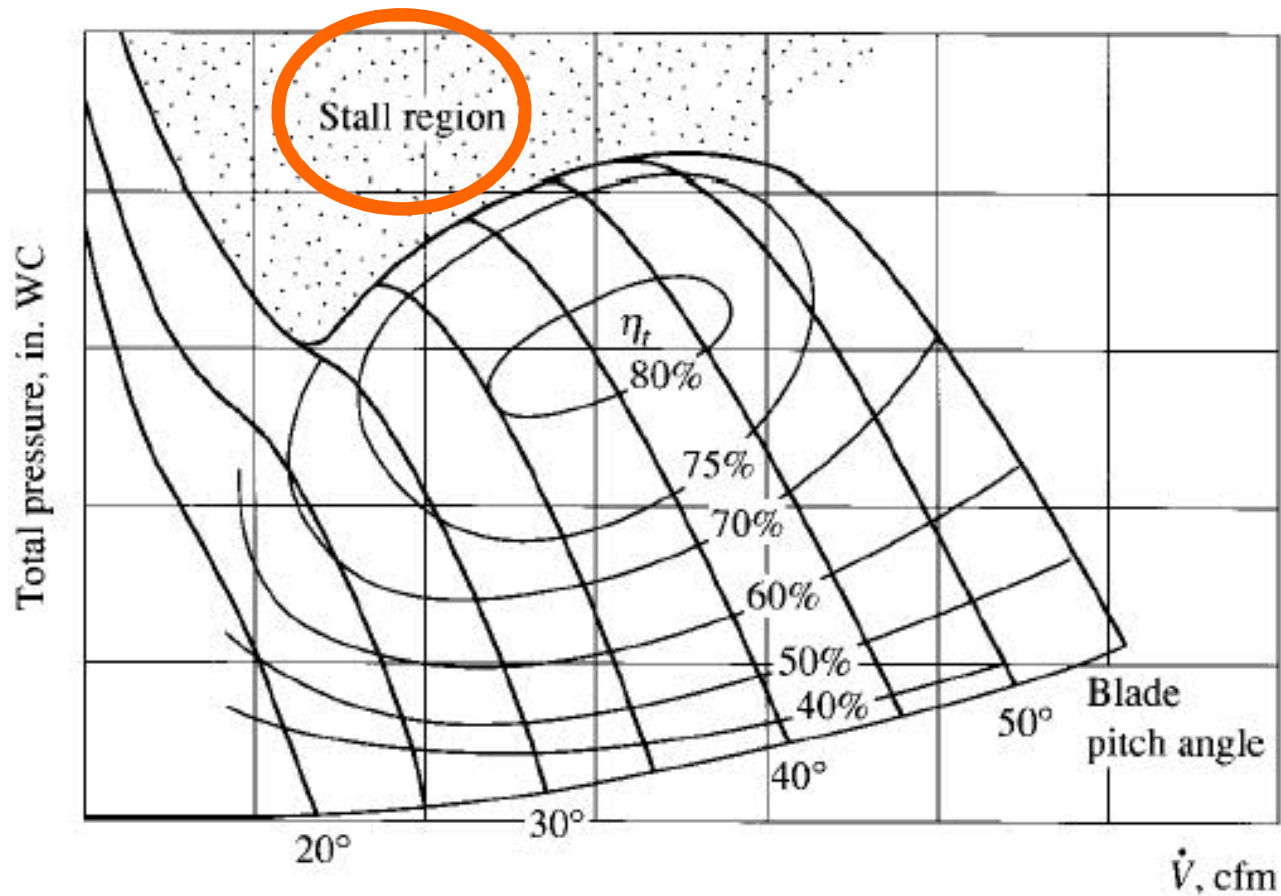

Stall and stall region of an axial fan

(Source: Wang, S. K., 2001. *Handbook of Air Conditioning and Refrigeration*)

Fan-duct Systems

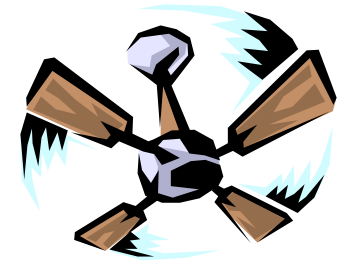

- Fan selection
 - Select fan type + determine fan size
 - Important factors:
 - Pressure-volume flow operating characteristics
 - Fan capacity modulation
 - Fan efficiency
 - Sound power level
 - Airflow direction
 - Initial cost

TABLE 15.2 Comparison between Various Types of Fans

	Backward, airfoil centrifugal fan	Forward-curved centrifugal fan	Vane-axial	Propeller fan
Fan total pressure Δp_{tf}	Higher Δp_t	Comparatively lower Δp_t	Higher Δp_t	Low Δp_t
Flow rate	All flow rates	Larger flow rate	All flow rates	Larger flow rate
Fan power input	Nonoverloading	Overloading	Nonoverloading	Nonoverloading
Fan modulation	Inlet vanes AC inverter	Inlet vanes AC inverter	Controllable pitch AC inverter	
Fan total efficiency	0.7 to 0.86	0.6 to 0.75	0.7 to 0.88	0.45 to 0.6
Sound power level	Lower, higher L_w at low frequencies	Medium, higher L_w at low frequencies	Medium, difference of L_w values is small at various Hz	Higher, higher L_w at high frequencies
Airflow direction	90° turn	90° turn	Parallel to axle	Parallel to axle
Volume and weight	Greater	Less	Greater	Medium volume and lower weight
Initial cost	Higher	Medium	Higher	Low
Applications	Large HVAC&R systems	Lower pressure, small HVAC&R systems	Large HVAC&R systems	Low-pressure, high- volume flow exhaust systems

(Source: Wang, S. K., 2001. *Handbook of Air Conditioning and Refrigeration*)

Duct Construction

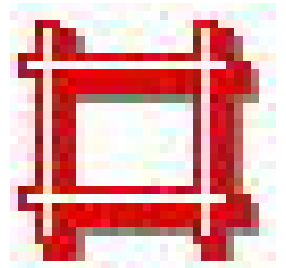

- Types of air duct
 - Supply air duct
 - Return air duct
 - Outdoor air duct
 - Exhaust air
- Duct sections
 - Header or main duct (trunk)
 - Branch duct or runout

Duct Construction

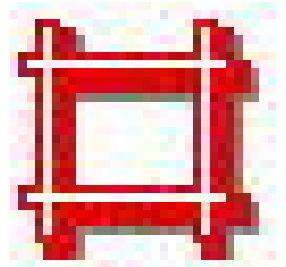

- Duct systems
 - Max. pressure difference (between air inside the duct and the ambient air)
 - 125, 250, 500, 750, 1000, 1500, 2500 Pa
 - Commercial buildings
 - Low-pressure duct system: ≤ 500 Pa, max 12 m/s
 - Medium-pressure system: 500-1500 Pa, max 17.5 m/s
 - Residential buildings: 125 Pa or 250 Pa
 - Industrial duct system: ΔP can be higher

Duct Construction

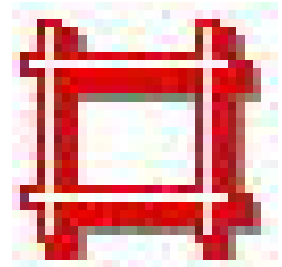

- Shapes of air duct
 - Rectangular
 - More easily fabricated on site, air leakage
 - Round
 - Less fluid resistance, better rigidity/strength
 - Flat oval
 - Flexible
 - Multiple-ply polyester film w/ metal wire or strips
- SMACNA (Sheet Metal and Air Conditioning Contractors' National Association) standards

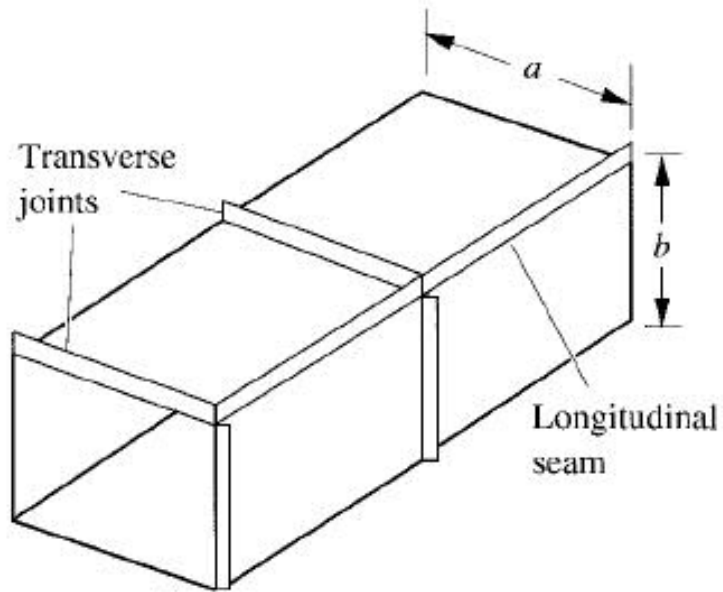

Rectangular duct

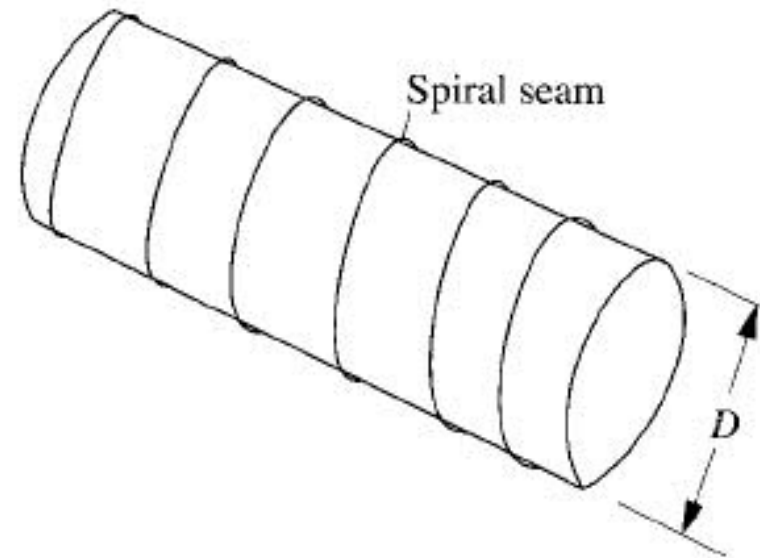

Round duct w/ spiral seam

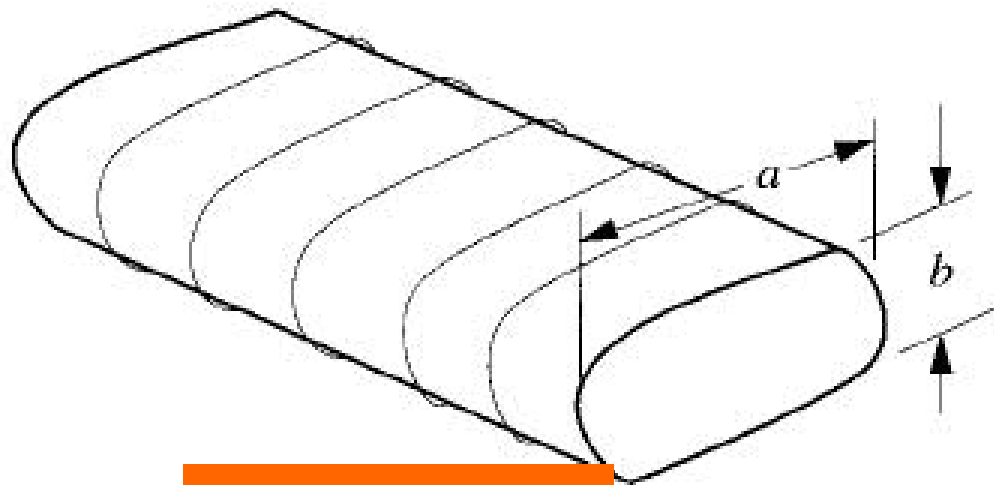

Flat oval duct

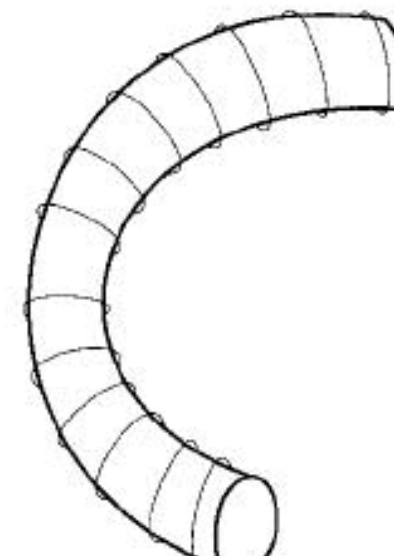

Flexible duct

Duct Construction

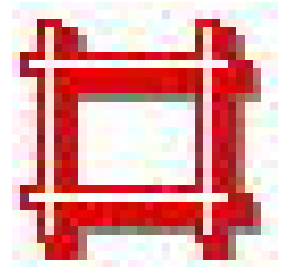

- Duct specification
 - Sheet gauge and thickness of duct material
 - Traverse joints & longitudinal seam reinforcements
 - Duct hangers & their spacing
 - Tapes & adhesive closures
 - Fire spread and smoke developed
 - Site-fabricated or factory-/pre-fabricated

Duct Construction

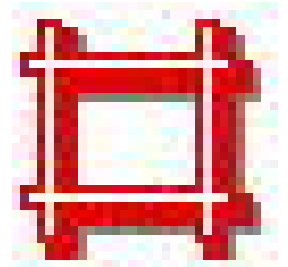

- Frictional losses

- Darcey-Weisbach Equation

- H_f = friction head loss, or Δp_f = pressure loss

$$H_f = f \left(\frac{L}{D} \right) \left(\frac{v^2}{2g} \right) \quad \Delta p_f = f \left(\frac{L}{D} \right) \left(\frac{\rho v^2}{2g_c} \right)$$

- f = friction factor (dimensionless)
 - L = length of duct or pipe (m)
 - D = diameter of duct or pipe (m)
 - v = mean air velocity in duct (m/s)

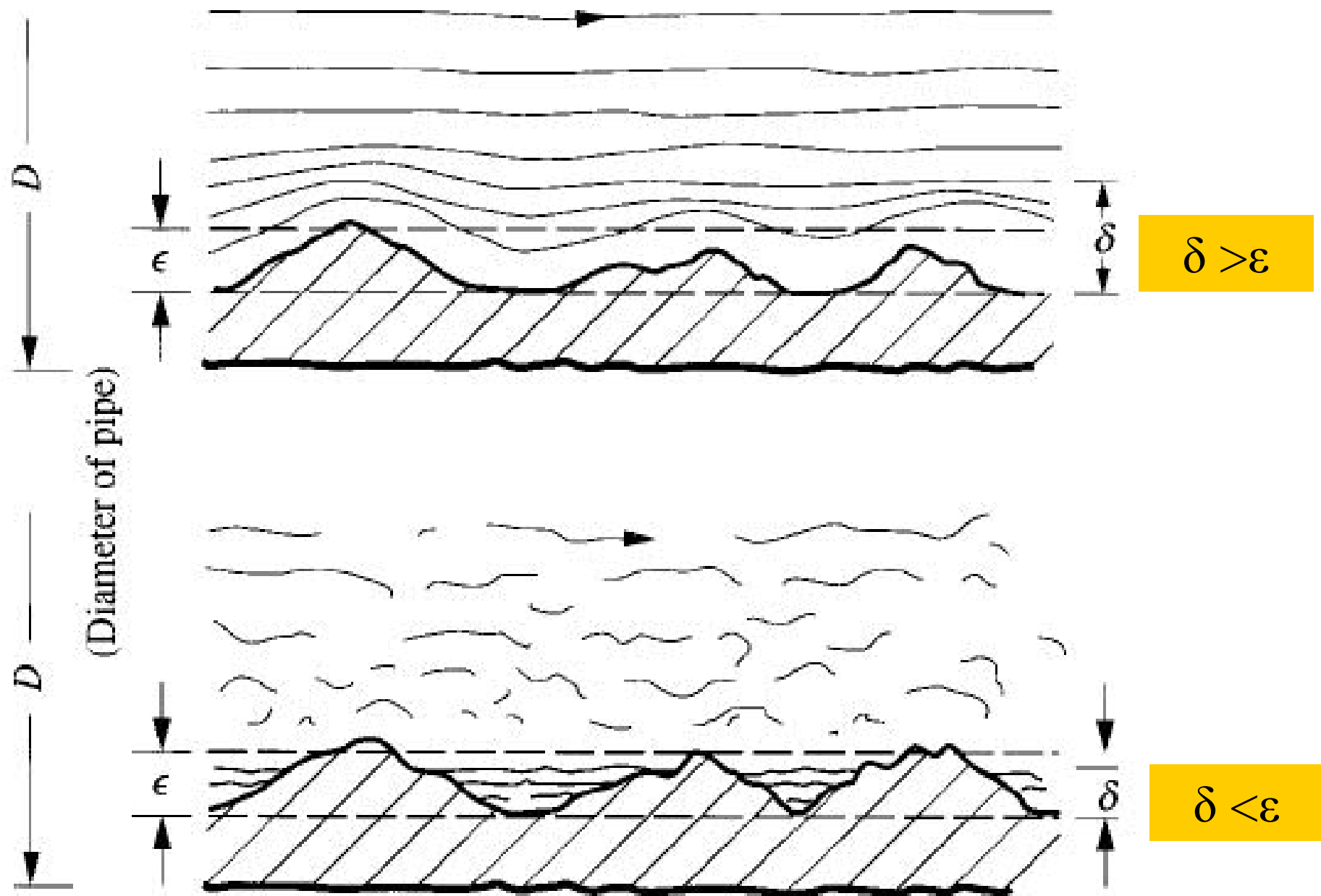

Mode of airflow when air passes over and around surface protuberances of the duct wall

(Source: Wang, S. K., 2001. Handbook of Air Conditioning and Refrigeration)

Duct Construction

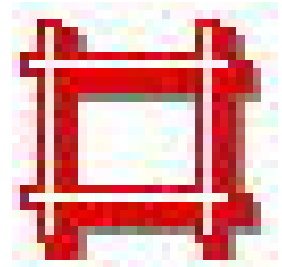

- Duct friction chart

- Colebrook formula
$$\frac{1}{\sqrt{f}} = -2 \log \left(\frac{\varepsilon}{3.7D} + \frac{2.51}{\text{Re}_D \sqrt{f}} \right)$$

- Roughness & temperature corrections

- $$\Delta p_f = K_{\text{sr}} K_T K_{\text{el}} \Delta p_{f,c}$$

- K_{sr} = correction factor for surface roughness

- K_T = correction factor for air temperature

- K_{el} = correction factor for elevation

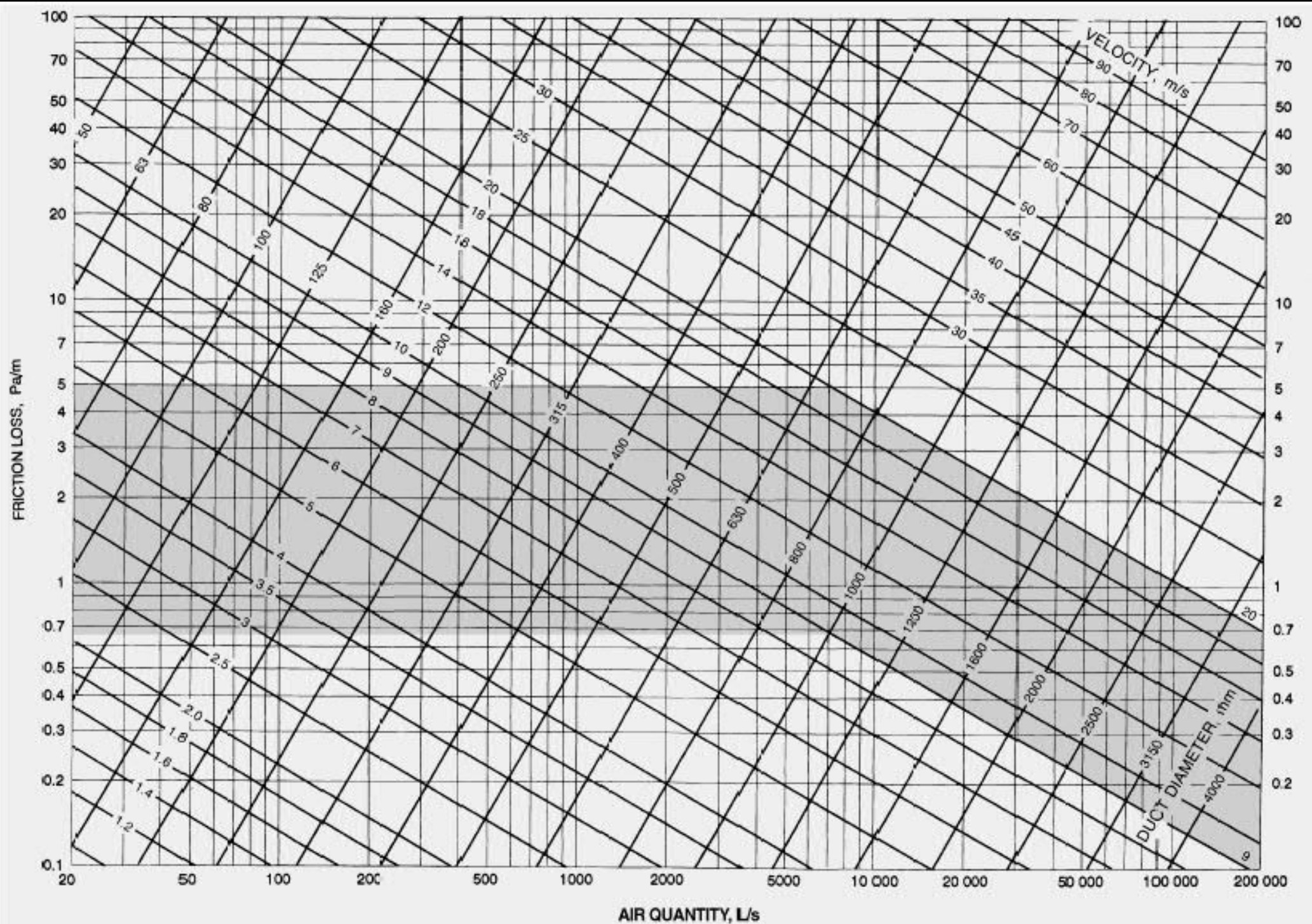

Friction chart for round duct

(Source: ASHRAE Handbook Fundamentals 2001)

Duct Construction

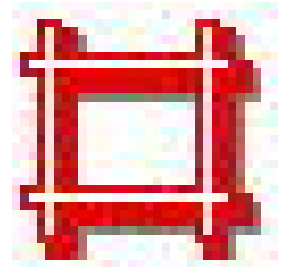

- Circular equivalent

- Hydraulic diameter, $D_h = 4 A / P$

- $A = \text{area (mm}^2\text{)}; P = \text{perimeter (mm)}$

- Rectangular duct:

$$D_e = \frac{1.30(ab)^{0.625}}{(a + b)^{0.25}}$$

- Flat oval duct:

$$D_e = \frac{1.55A^{0.625}}{P^{0.25}}$$

$$A = \frac{\pi b^2}{4} + b(a - b)$$

$$P = \pi b + 2(a + b)$$

Duct Construction

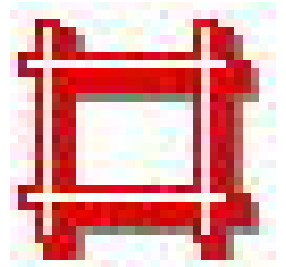

- Dynamic losses
 - Result from flow disturbances caused by duct-mounted equipment and fittings
 - Change airflow path's direction and/or area
 - Flow separation & eddies/disturbances
 - In dynamic similarity (same Reynolds number & geometrically similar duct fittings), dynamic loss is proportional to their velocity pressure

Duct Construction

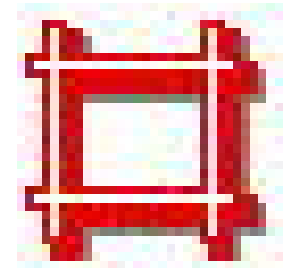

- Local or dynamic loss coefficient
 - Ratio of total pressure loss to velocity pressure

$$C = \frac{\Delta p_j}{(\rho V^2 / 2)} = \frac{\Delta p_j}{p_v}$$

where

C = local loss coefficient, dimensionless

Δp_j = total pressure loss, Pa

ρ = density, kg/m³

V = velocity, m/s

p_v = velocity pressure, Pa

FITTING LOSS COEFFICIENTS

Fittings to support [Examples 8](#) and [9](#) and some of the more common fittings are reprinted here.

For the complete fitting database see the *Duct Fitting Database* (ASHRAE 1994).

ROUND FITTINGS

CD3-1 Elbow, Die Stamped, 90 Degree, $r/D = 1.5$

D , mm	75	100	125	150	180	200	230	250
C_o	0.30	0.21	0.16	0.14	0.12	0.11	0.11	0.11

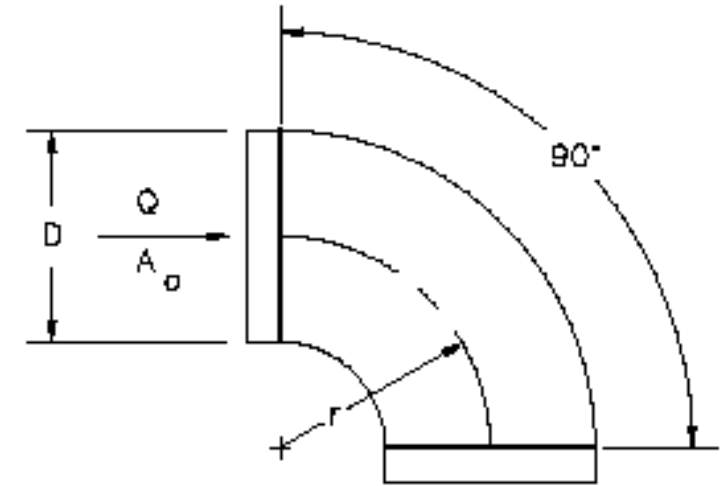

CD3-3 Elbow, Die Stamped, 45 Degree, $r/D = 1.5$

D , mm	75	100	125	150	180	200	230	250
C_o	0.18	0.13	0.10	0.08	0.07	0.07	0.07	0.07

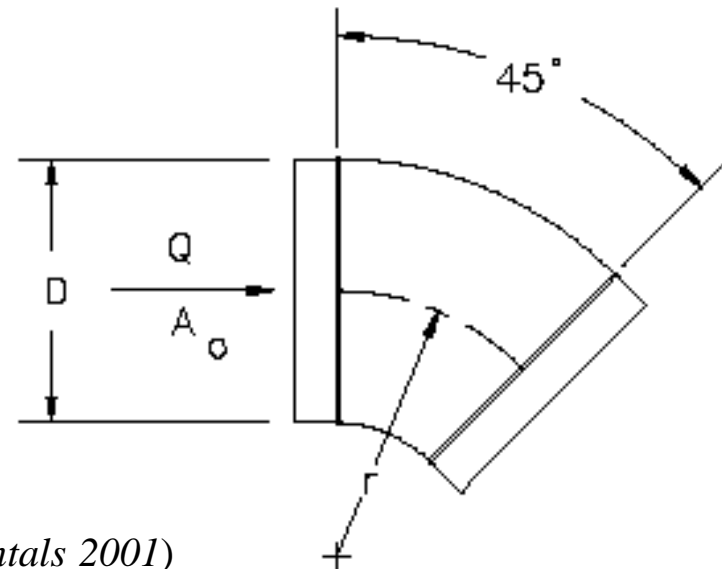

(Source: *ASHRAE Handbook Fundamentals 2001*)

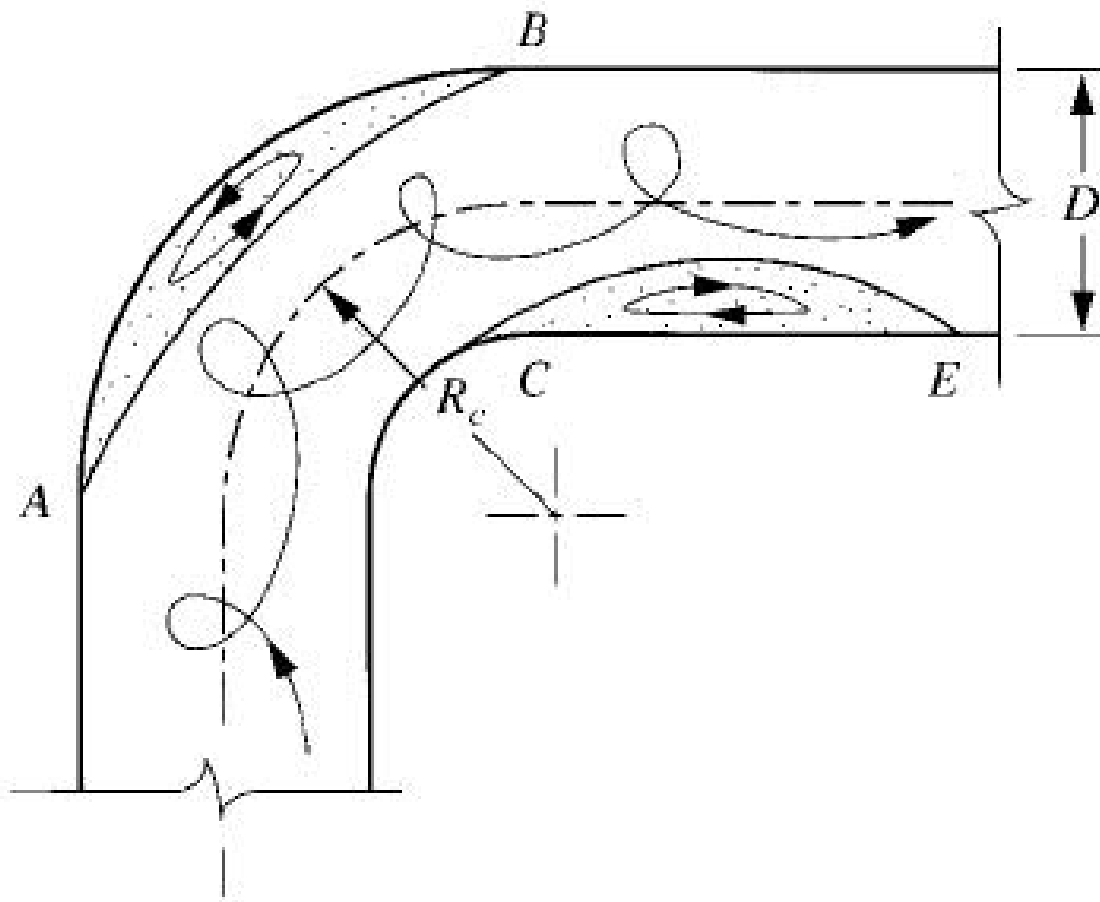

Region of eddies and turbulences in a round elbow

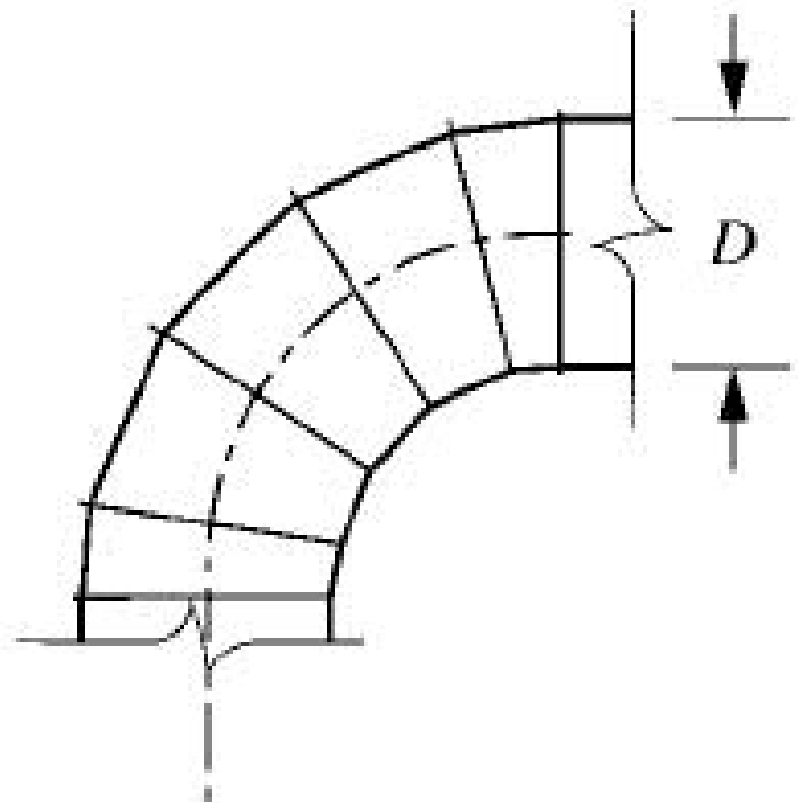

5-piece 90° round elbow

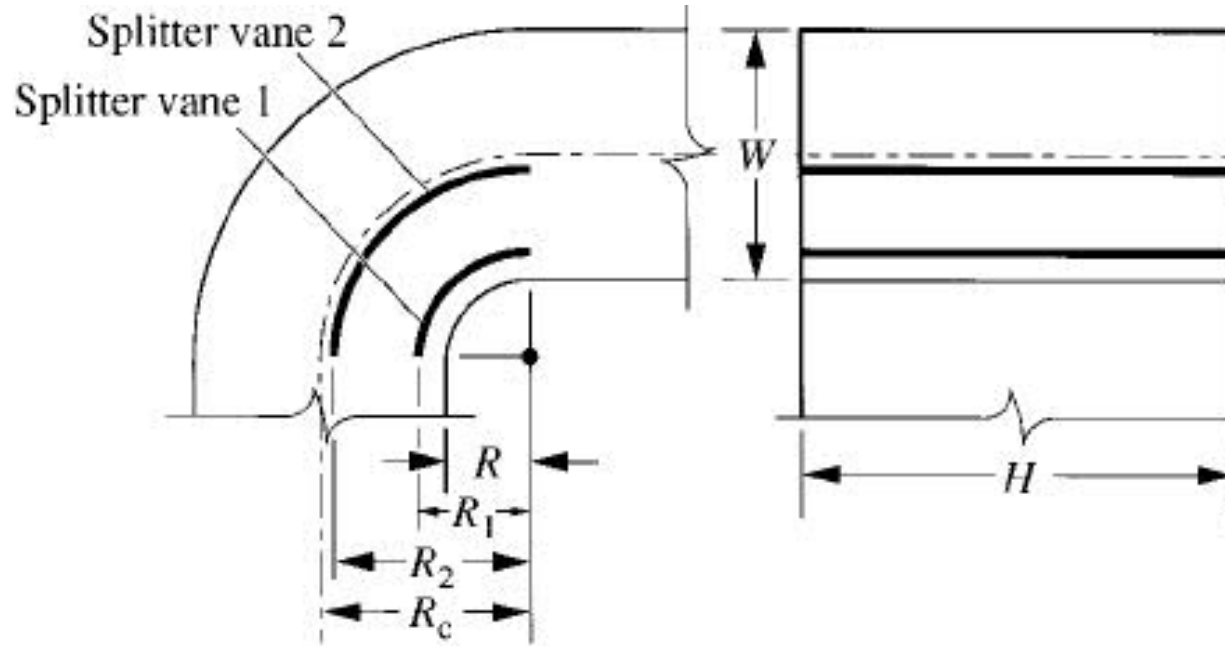

Rectangular elbow, smooth radius, 2 splitter vanes

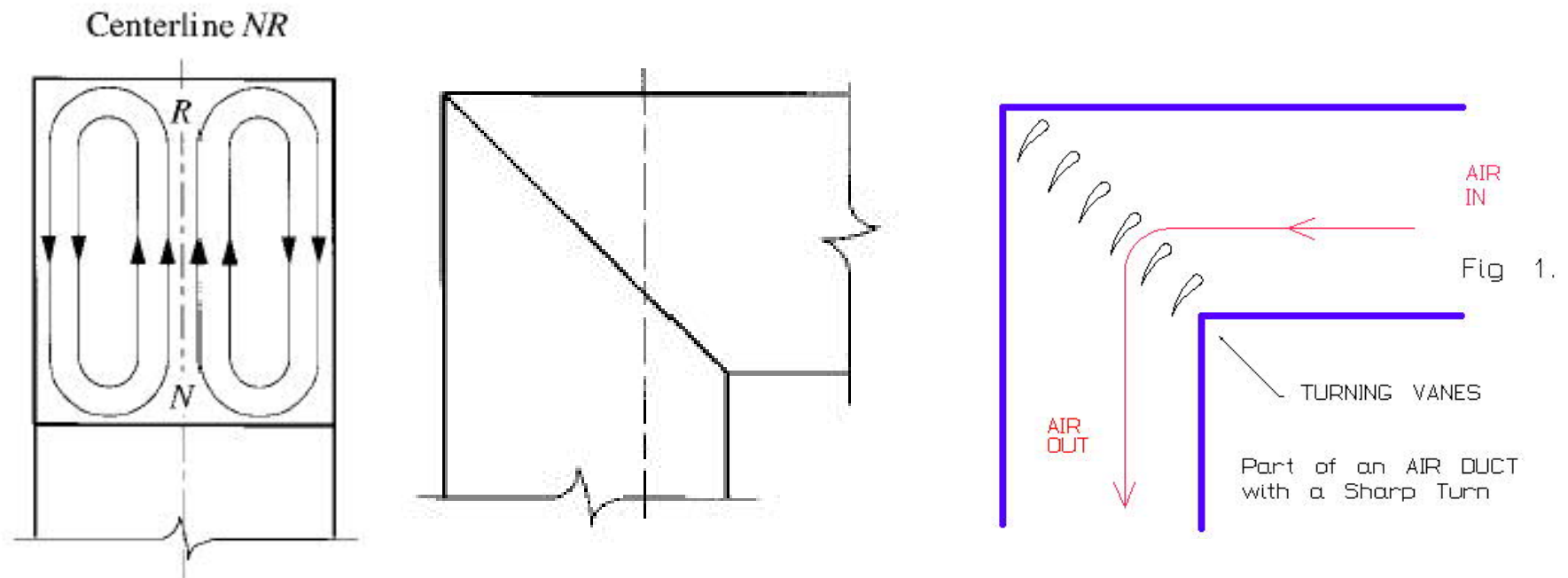

Mitered elbow and its secondary flow

(Source: ASHRAE Handbook Fundamentals 2001)

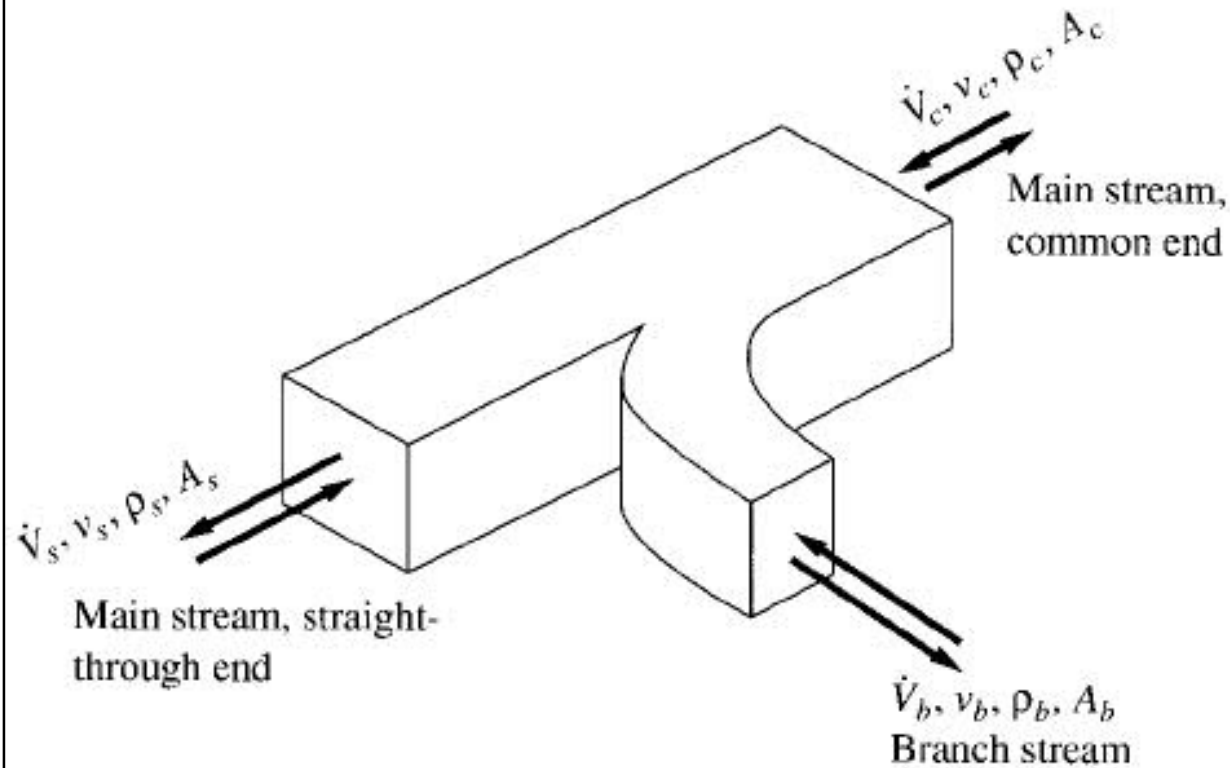
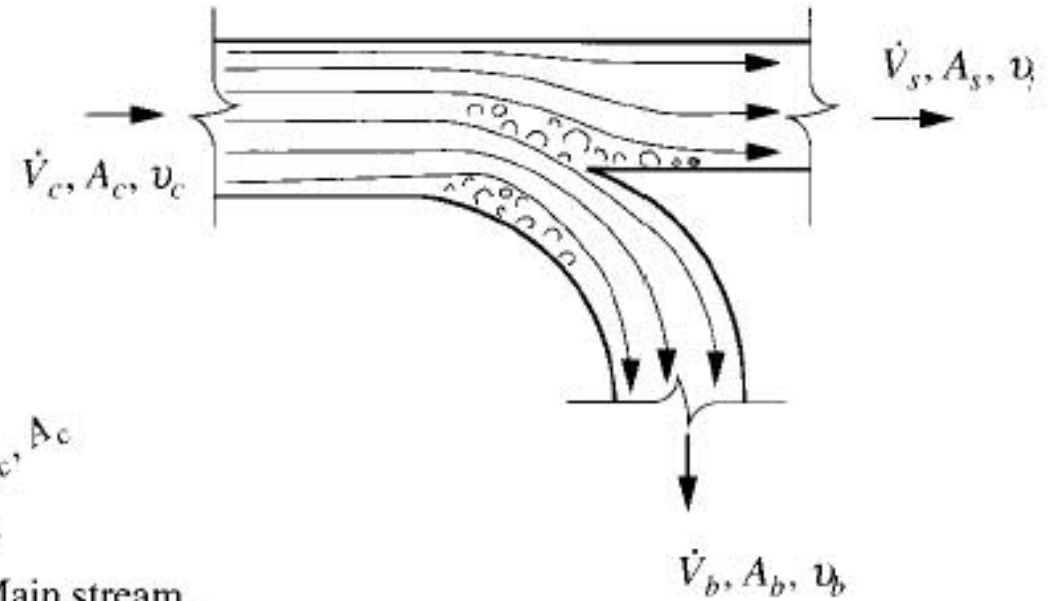
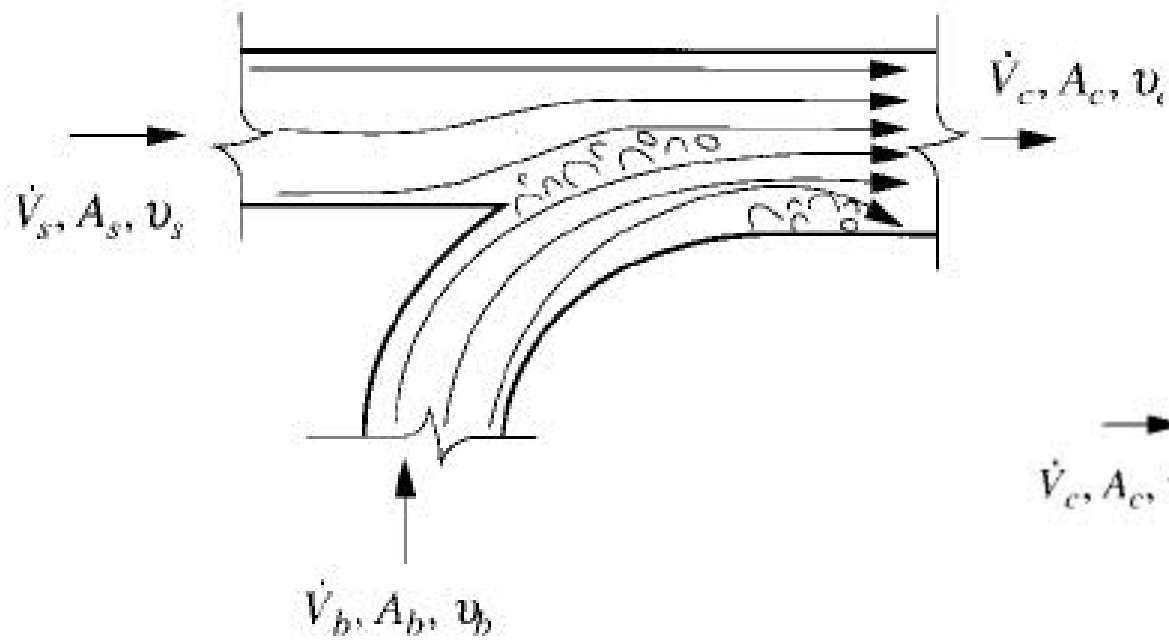

Airflow through a rectangular converging or diverging wye

Entrance

Exit

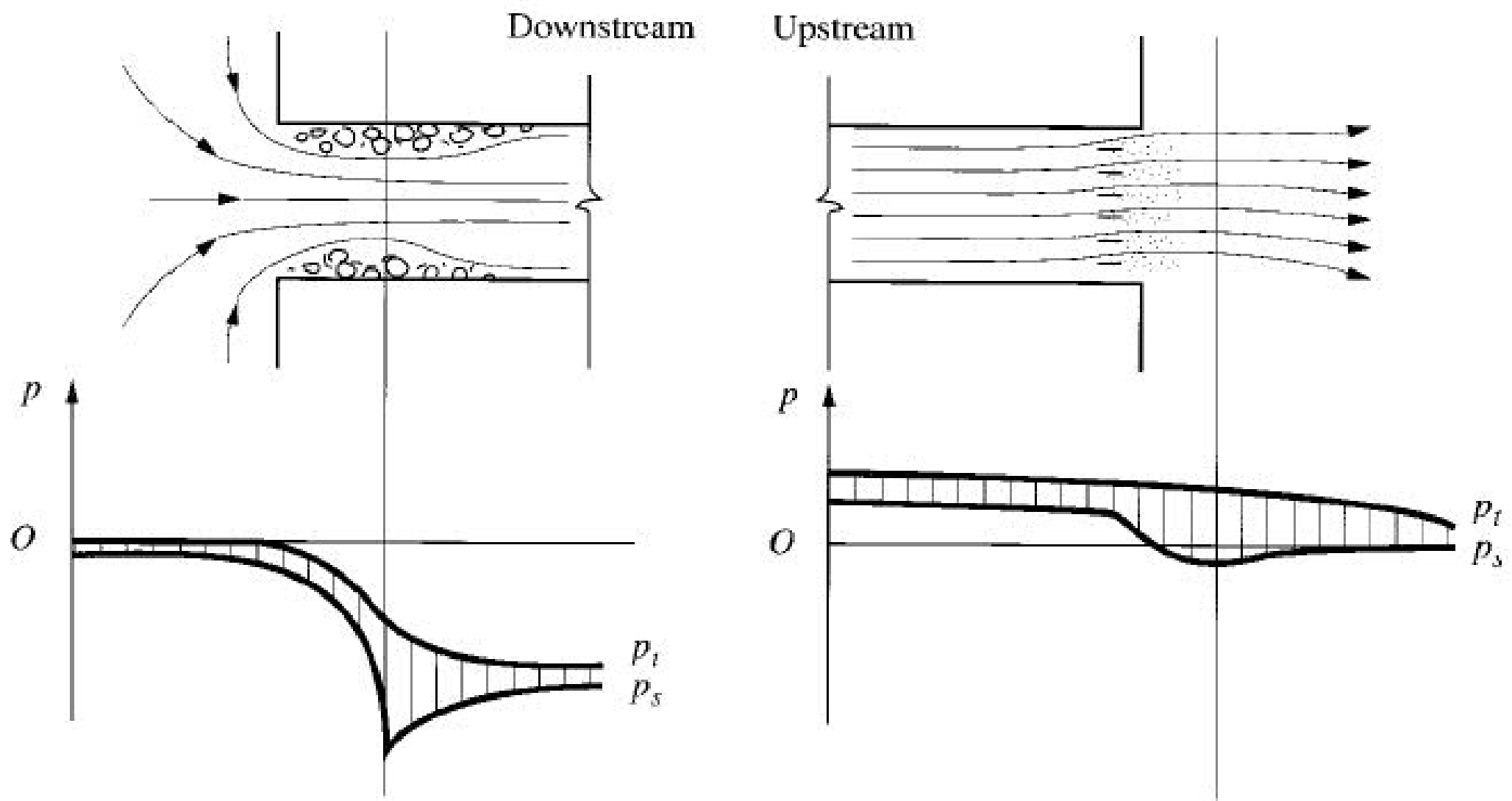

(Source: Wang, S. K., 2001. Handbook of Air Conditioning and Refrigeration)

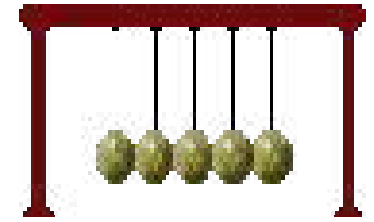

Air Duct Design

- Optimal air duct design
 - Optimal duct system layout, space available
 - Satisfactory system balance
 - Acceptable sound level
 - Optimum energy loss and initial cost
 - Install only necessary balancing devices (dampers)
 - Fire codes, duct construction & insulation
- Require comprehensive analysis & care for different transport functions

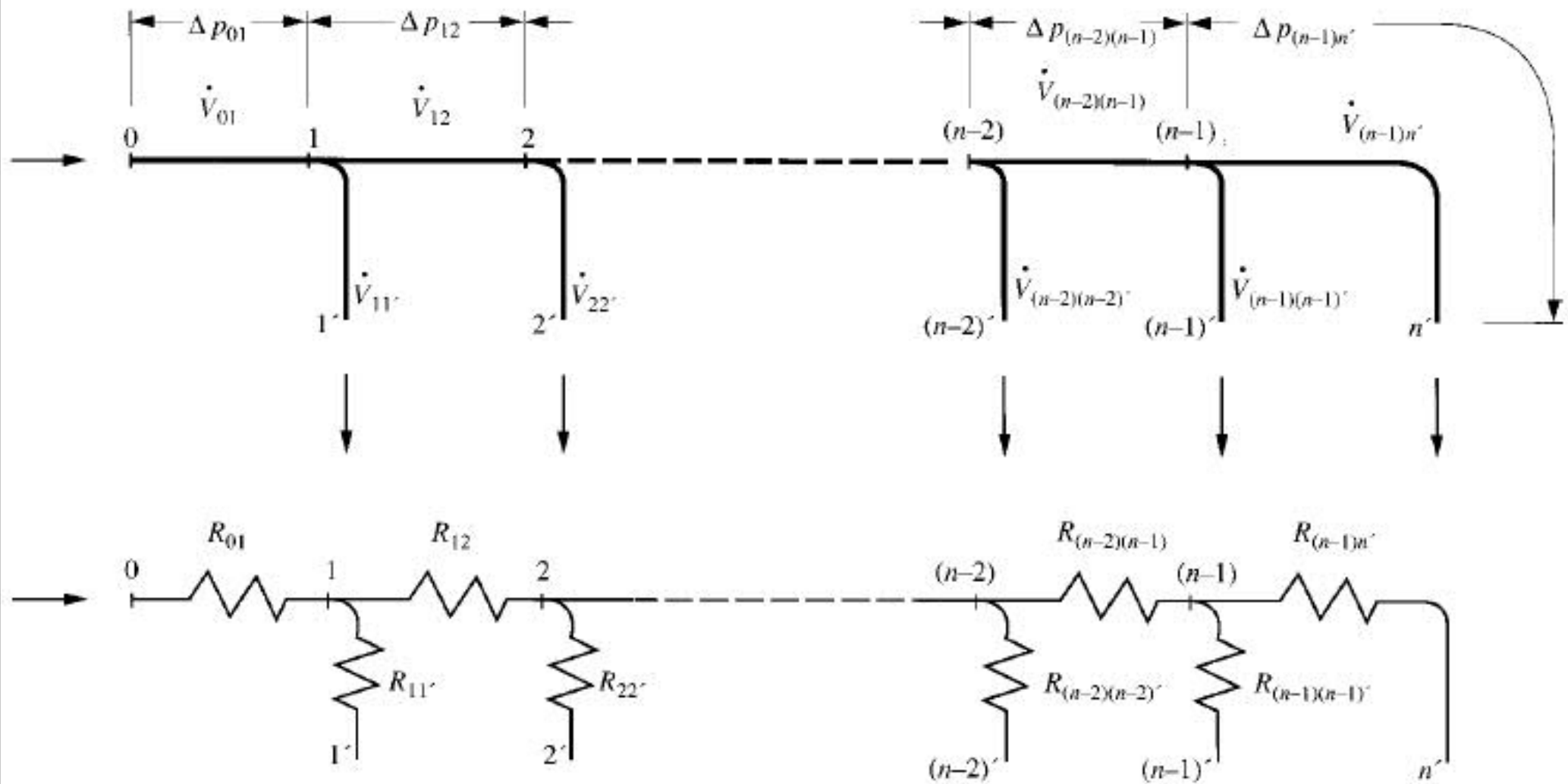

Flow characteristics of a supply duct system

(Source: Wang, S. K., 2001. Handbook of Air Conditioning and Refrigeration)

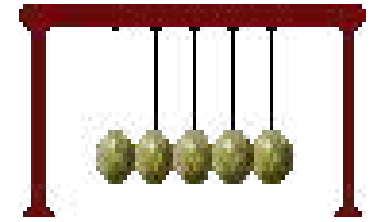

Air Duct Design

- Design velocity
 - Constraints: space available, beam depth
 - Typical guidelines:
 - Main ducts: air flow usually ≤ 15 m/s; air flow noise must be checked
 - With more demanding noise criteria (e.g. hotels), max. air velocity: main duct $\leq 10-12.5$ m/s, return main duct ≤ 8 m/s, branch ducts ≤ 6 m/s
 - Face velocities for air-handling system components

Table 10 Typical Design Velocities for HVAC Components

Duct Element	Face Velocity, m/s
LOUVERS^a	
Intake	
3300 L/s and greater	2
Less than 3300 L/s	See Figure 15
Exhaust	
2400 L/s and greater	2.5
Less than 2400 L/s	See Figure 15
FILTERS^b	
Panel filters	
Viscous impingement	1 to 4
Dry-type, extended-surface	
Flat (low efficiency)	Duct velocity
Pleated media (intermediate efficiency)	Up to 3.8
HEPA	1.3
Renewable media filters	
Moving-curtain viscous impingement	2.5
Moving-curtain dry media	1
Electronic air cleaners	
Ionizing type	0.8 to 1.8
HEATING COILS^c	
Steam and hot water	2.5 to 5 1 min., 8 max.
Electric	
Open wire	Refer to mfg. data
Finned tubular	Refer to mfg. data
DEHUMIDIFYING COILS^d	
	2 to 3
AIR WASHERS^e	
Spray type	1.5 to 3.0
Cell type	Refer to mfg. data
High-velocity spray type	6 to 9

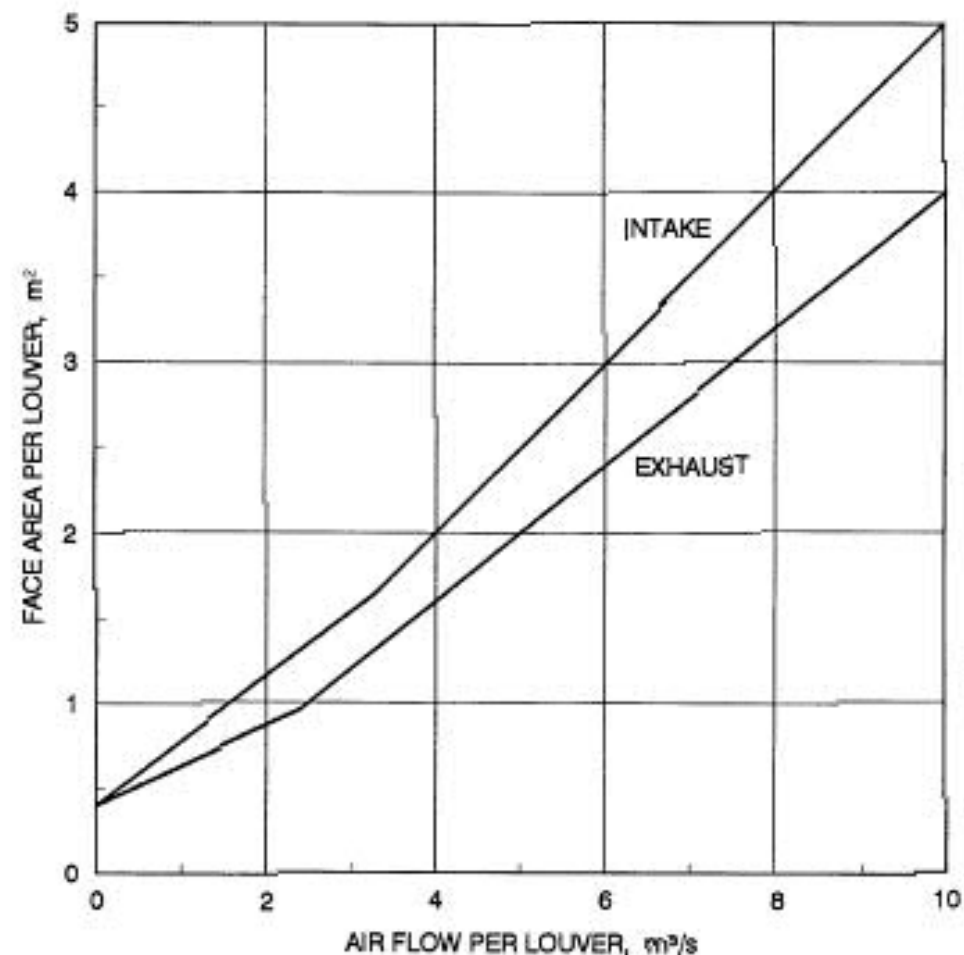

Parameters Used to Establish Figure	Intake Louver	Exhaust Louver
Minimum free area (1220 mm square test section), %	45	45
Water penetration, $\mu\text{L}/(\text{m}^2 \cdot \text{s})$	Negligible (less than 0.6)	na
Maximum static pressure drop, Pa	35	60

Fig. 15 Criteria for Louver Sizing

(Source: ASHRAE Handbook Fundamentals 2001)

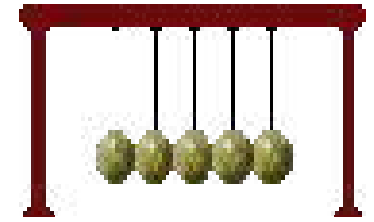

Air Duct Design

- Reduce dynamic losses of the critical path
 - Maintain optimum air velocity through duct fittings
 - Emphasize reduction of dynamic losses nearer to the fan outlet or inlet (high air velocity)
 - Proper use of splitter vanes
 - Set 2 duct fittings as far apart as possible
- Air duct leakage
 - Duct leakage classification
 - AISI, SMACNA, ASHRAE standards

Air Duct Design

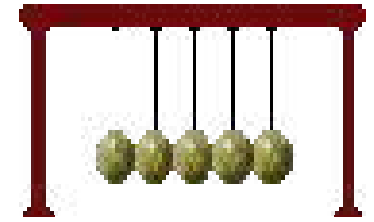

- Fire protection
 - Duct material selection
 - Vertical ducts (using masonry, concrete or clay)
 - When ducts pass through floors & walls
 - Use of fire dampers
 - Filling the gaps between ducts & bldg structure
 - Duct systems for industrial applications
- Any other fire precautions?

Air Duct Design

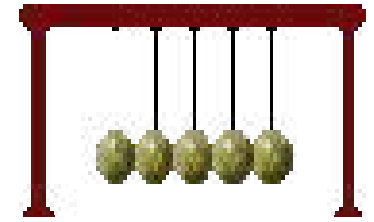

- Design procedure (computer-aided or manual)
 - Verify local codes & material availability
 - Preliminary duct layout
 - Divide into consecutive duct sections
 - Minimise local loss coefficients of duct fittings
 - Select duct sizing methods
 - Critical total pressure loss of tentative critical path
 - Size branch ducts & balance total pressure at junctions
 - Adjust supply flow rates according to duct heat gain
 - Resize duct sections, recalculate & balance parallel paths
 - Check sound level & add necessary attenuation

Air Duct Design

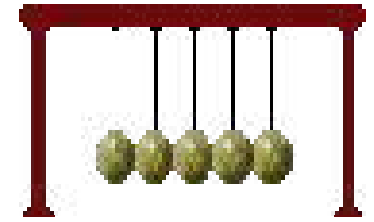

- Duct layout
 - Symmetric layout is easier to balance
 - Smaller main duct & shorter design path
 - For VAV systems, duct looping allows feed from opposite direction
 - Optimise transporting capacity (balance points often follow the sun's position)
 - Result in smaller main duct
 - Compare alternative layouts & reduce fittings
 - For exposed ducts, appearance & integration with the structure is important

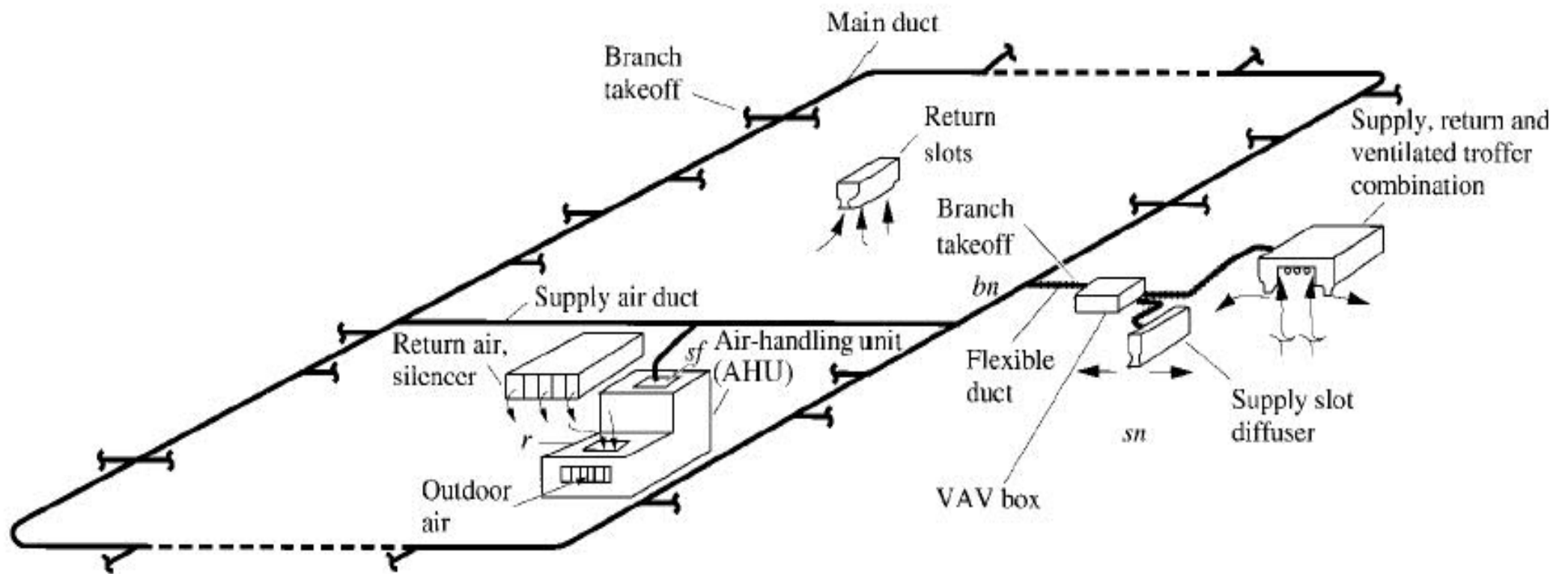

Typical supply duct system with symmetric layout & looping

(Source: Wang, S. K., 2001. Handbook of Air Conditioning and Refrigeration)

Air Duct Design

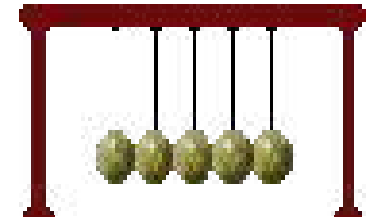

- Duct sizing methods
 - **Equal-friction method** with maximum velocity
 - Duct friction loss per unit length remains constant
 - Most widely used in normal HVAC applications
 - **Constant-velocity method**
 - Often for exhaust ventilation system
 - Minimum velocity to carry dust is important
 - Limit velocity to reduce noise

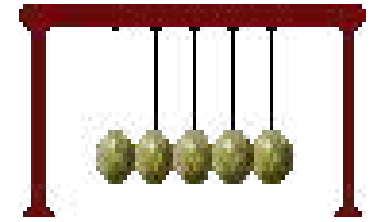

Air Duct Design

- Duct sizing methods
 - **Static regain method**
 - Normally used with a computer package for high velocity systems (e.g. in main duct)
 - Size air duct so that \uparrow static pressure nearly offset the pressure loss of succeeding duct section along main duct
 - **T method**
 - Optimising procedure by minimising life-cycle cost
 - System condensing (into a single imaginary duct)
 - Fan selection (optimum system pressure loss)
 - System expansion (back to original duct system)

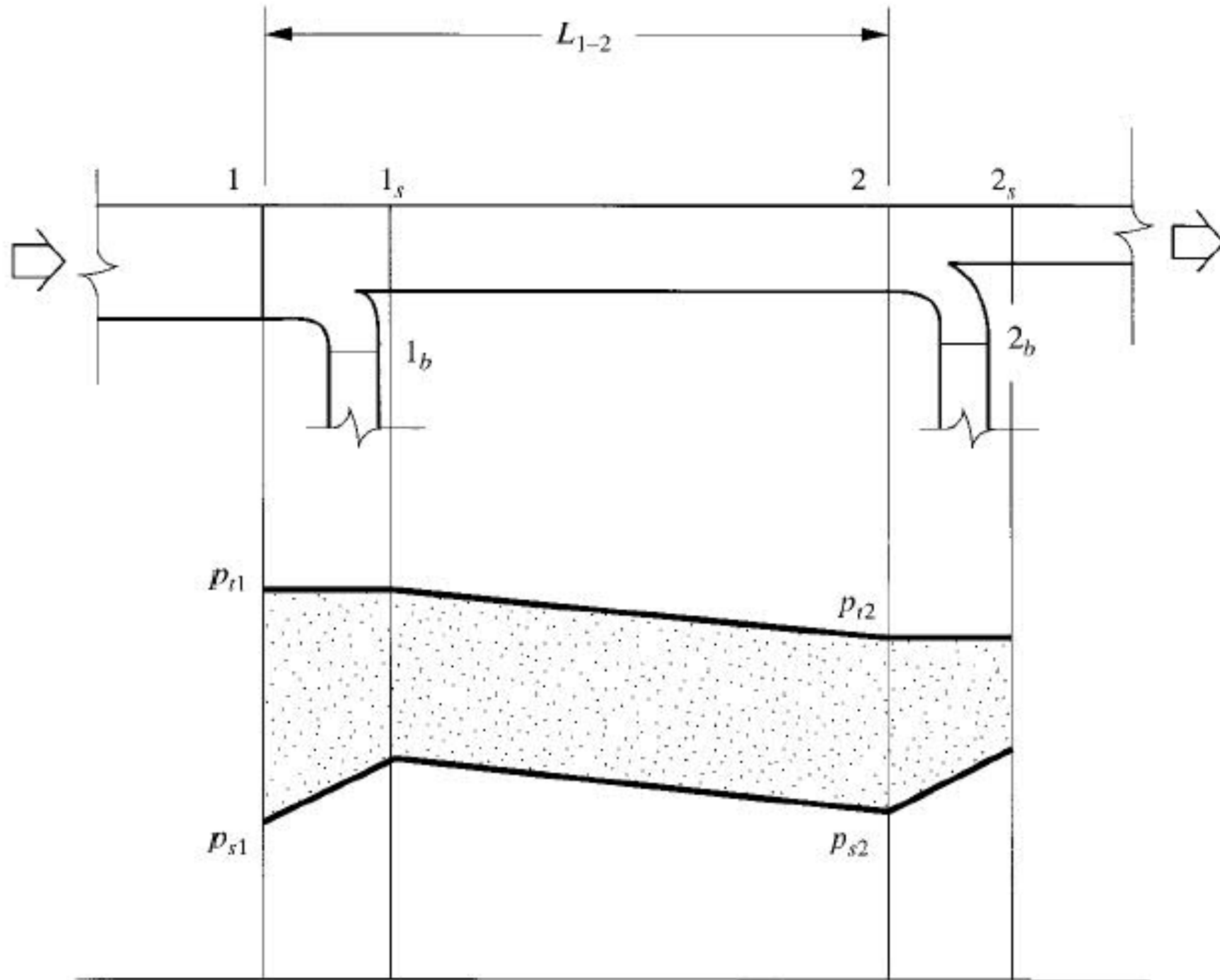

Concept of static regain method

(Source: Wang, S. K., 2001. Handbook of Air Conditioning and Refrigeration)

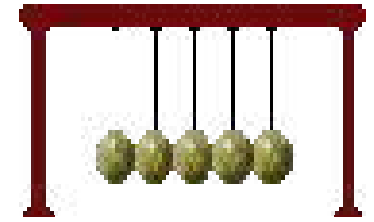

Air Duct Design

- Duct liner
 - Lined internally on inner surface of duct wall
 - Mainly used for noise attenuation & insulation
 - Fiberglass blanket or boards
- Duct cleaning
 - Prevent accumulation of dirt & debris
 - Agitation device to loosen the dirt & debris
 - Duct vacuum to extract loosened debris
 - Sealing of access openings

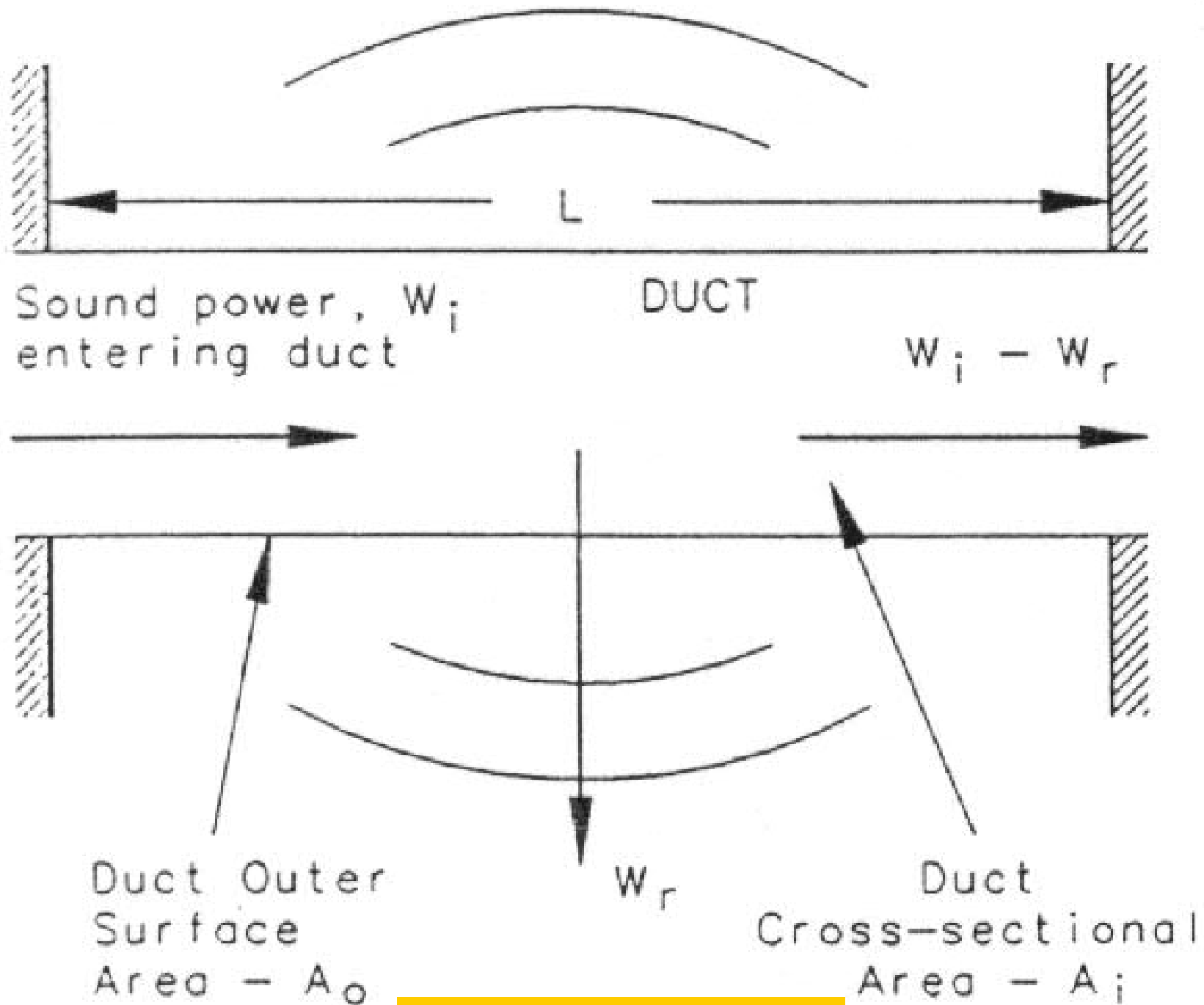

Duct breakout noise

(Source: Wang, S. K., 2001. Handbook of Air Conditioning and Refrigeration)



Further Reading

- *ASHRAE Systems and Equipment Handbook 2012*, SI edition, Chp. 20 - Fans
- *ASHRAE Handbook Fundamentals 2009*, Chp. 21 - Duct Design
- Race, G. L. and Mitchell, S., 2003. *A Practical Guide to HVAC Building Services Calculations*, Building Services Research and Information Association, Bracknell, Berkshire, England, pp. 79-95. [697 R1 p][697 R1 p8]
- Wang, S. K., 2001. *Handbook of Air Conditioning and Refrigeration*, 2nd ed., Chps. 15 & 17, McGraw-Hill, New York. [697.93 W24 h]