

# Light Sources and Systems

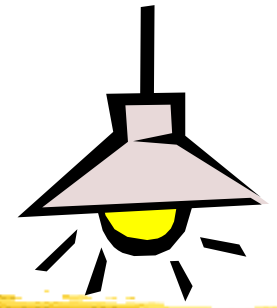


*Ir. Dr. Sam C. M. Hui*

Faculty of Science and Technology

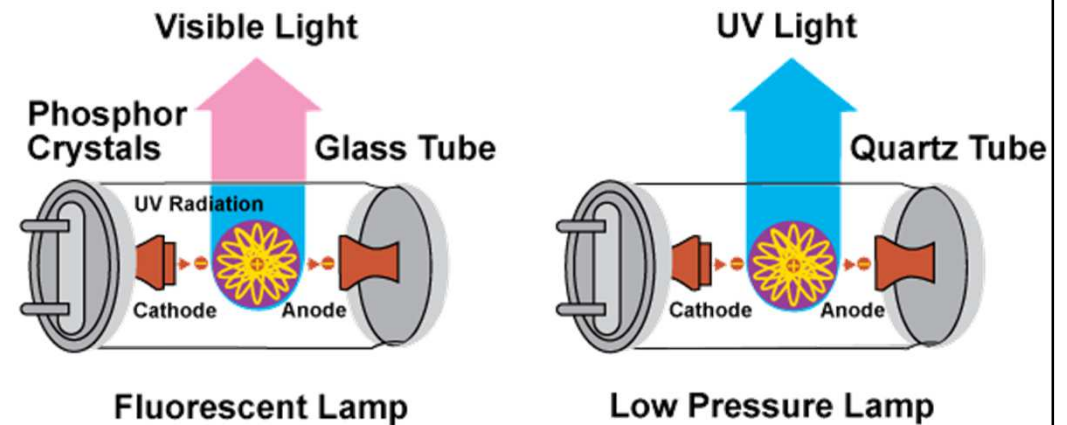
E-mail: [cmhui@vtc.edu.hk](mailto:cmhui@vtc.edu.hk)

# Light Sources



- Mechanism for production of light radiation:

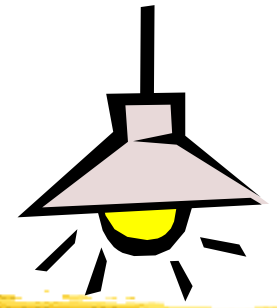
- Incandescence
- Electric discharges
- Electroluminescence
- Luminescence
- Radioluminescence
- Cathodoluminescence
- Chemiluminescence
- Thermoluminescence





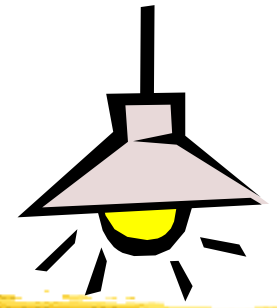
Examples of light sources for general lighting  
(Source: Advanced Lighting Guidelines, [www.algonline.org](http://www.algonline.org))

# Light Sources



- Commonly used light sources (abbrev./code)
  - Incandescent filament (I or GLS = general lighting service)
  - Tungsten-halogen (TH or H)
  - Fluorescent (F)
  - High intensity discharge (HID)
    - Metal halide (MH or MBI or M)
    - Mercury vapour (MBF or HPMV or Q)
    - High pressure sodium (HPS or S or SON)
  - Low pressure sodium (LPS or LS or SOX)

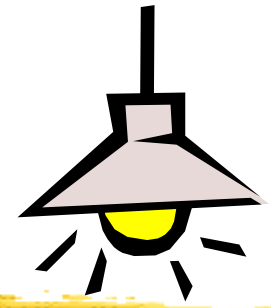
# Light Sources



- Other light sources
  - Induction lamps
  - Light emitting diodes (LEDs)
  - Electroluminescent lamps
  - Lasers
  - Combustion sources
    - Candle flame
    - Gas light (e.g. using kerosene)

(\* See also [http://en.wikipedia.org/wiki/List\\_of\\_light\\_sources](http://en.wikipedia.org/wiki/List_of_light_sources))

# Light Sources

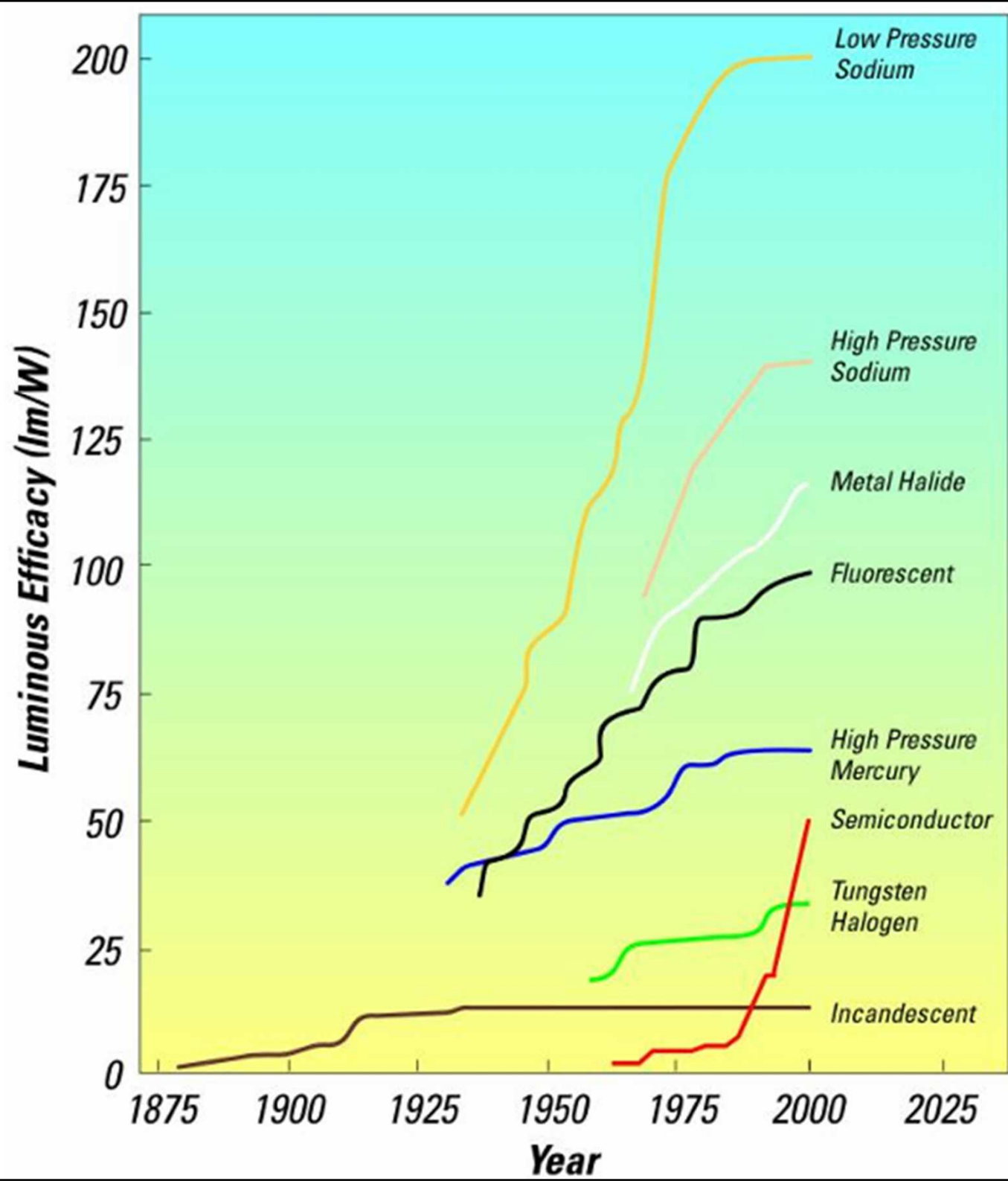


- 10 principal families of lamps (according to the manner of light emission) [*CIBSE/SLL Lighting Code*]
  - 1. Tungsten filament
  - 2. Tungsten halogen
  - 3. Metal halide
  - 4. Low pressure mercury (fluorescent)
  - 5. High pressure mercury
  - 6. Compact fluorescent (CFL)
  - 7. Low pressure sodium
  - 8. High pressure sodium
  - 9. Light emitting diodes (LED)
  - 10. Induction (mercury, sodium & sulphur)

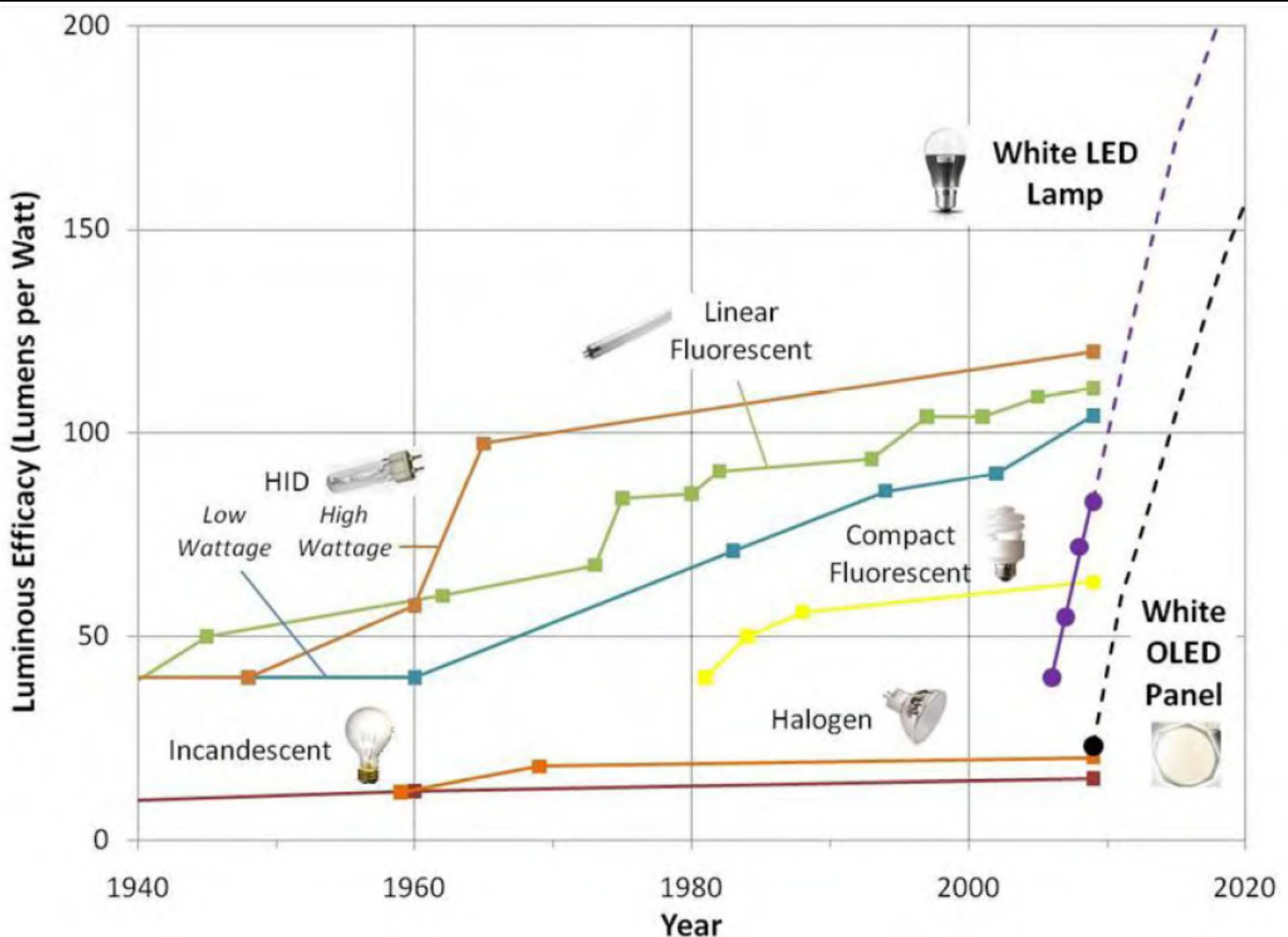


# Trends in luminous efficacy of lamps

(Source: LampTech,  
<http://www.lamptech.co.uk/>)





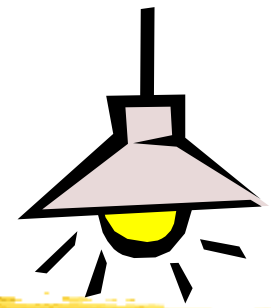


Historical and predicted efficacy of light sources

(Source: US Department of Energy)



# Incandescent

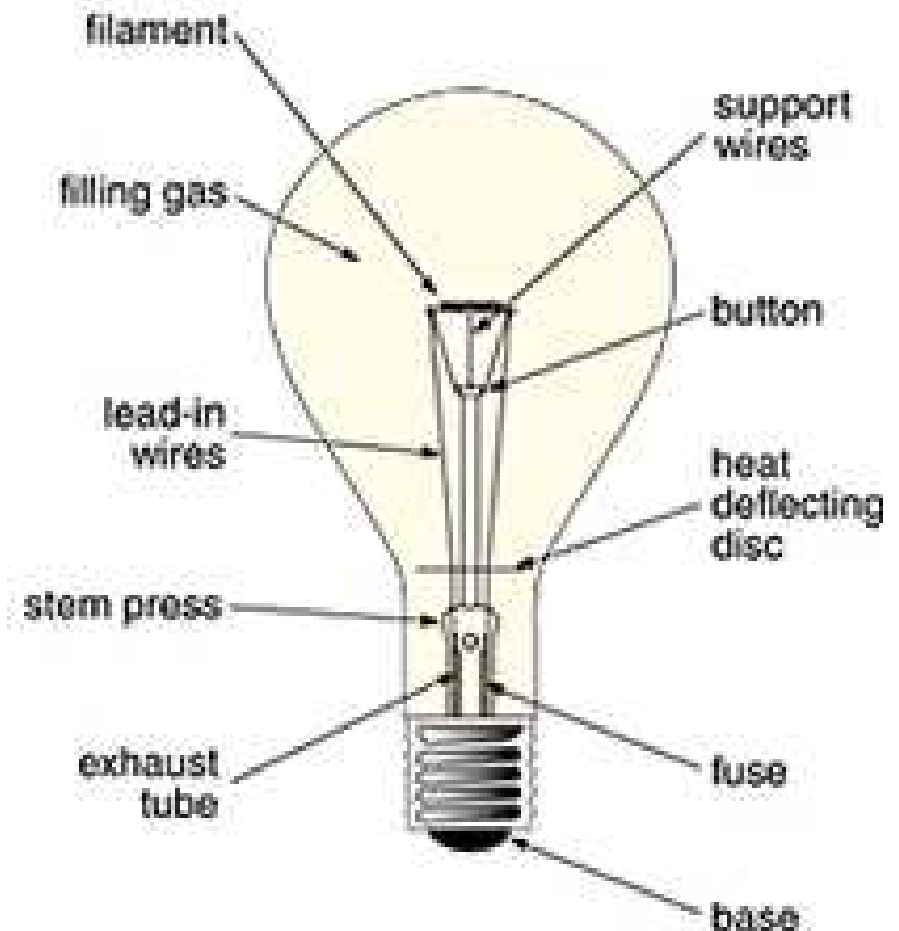


- Advantages

- Low initial cost
- Inexpensive to dim
- High colour rendering
- Can enhance texture

- Disadvantages

- Lowest efficacy
- Voltage sensitive
- Short life
- Heat generation



# Tungsten halogen cycle for incandescent lamp

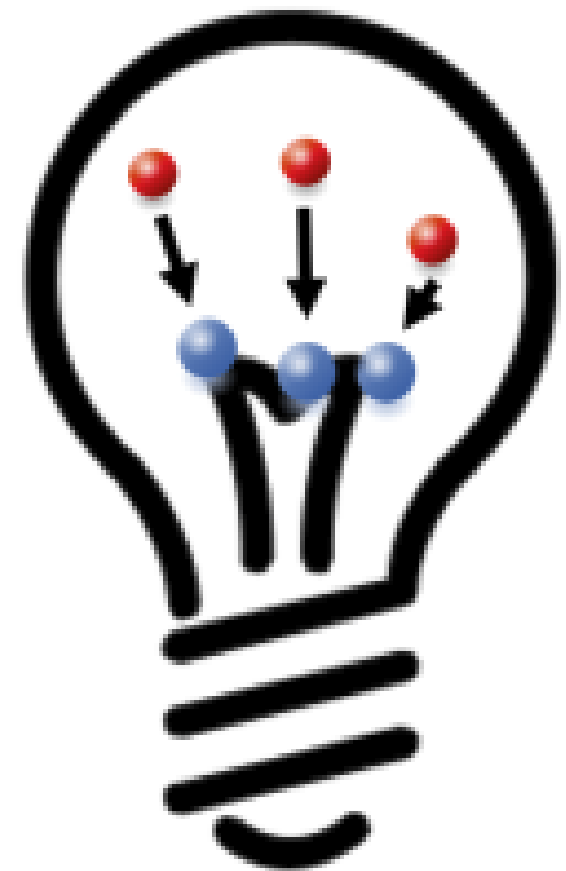


Tungsten evaporates from filament

 Tungsten     Halogen

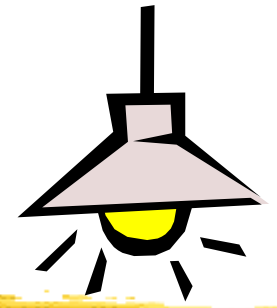


Evaporated tungsten reacts with halogen to form tungsten halide

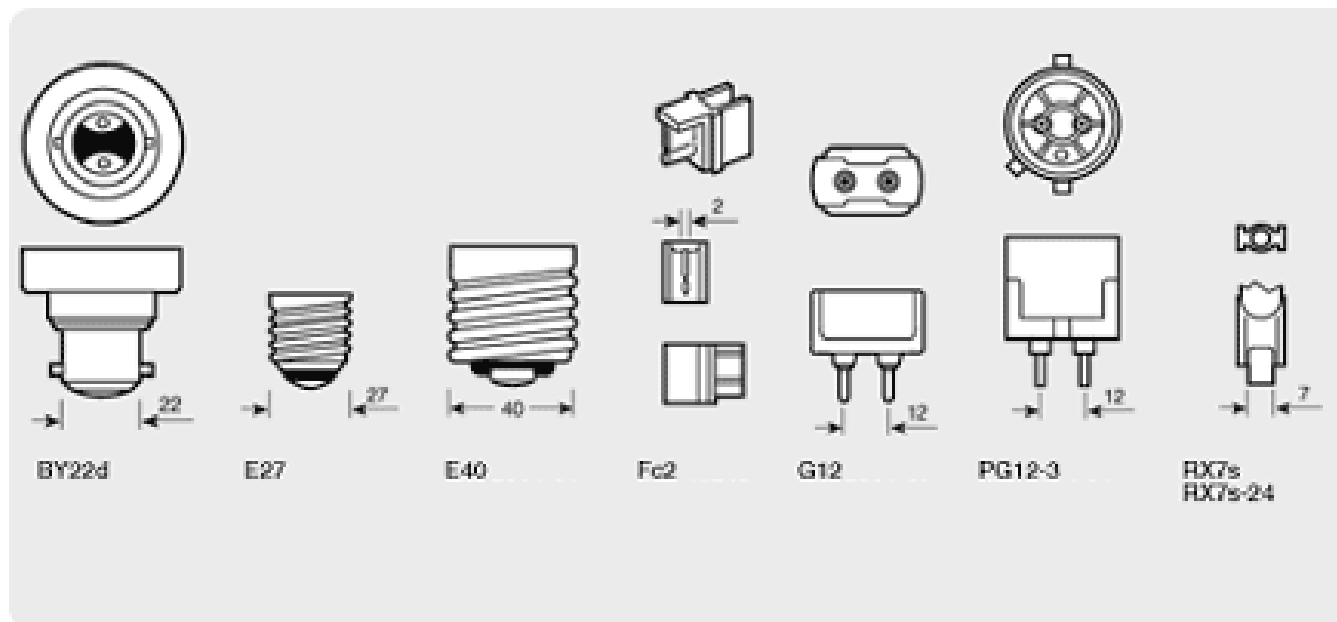


Tungsten halide dissociates, tungsten redeposits onto filament

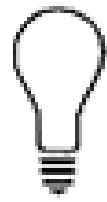
# Incandescent



- Specification
  - Lamp/Bulb shape designations
  - Typical filament construction
  - Common lamp bases



# Lamp shapes and bases



Type A



Type B



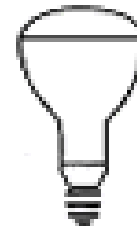
Type BA



Type BR



Type C



Type ER



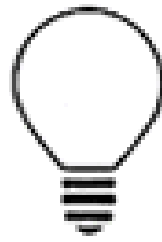
Type F



Type G



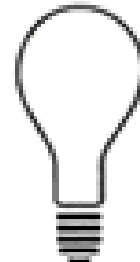
Type K



Type P



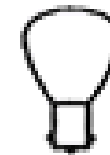
Type PAR



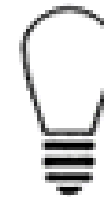
Type PS



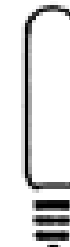
Type R



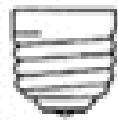
Type RP



Type S



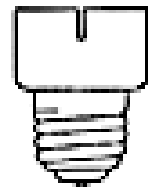
Type T



Medium  
(Standard)



3 Cont.  
Med.



Med.  
Skirted



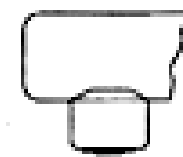
Mogul



3 Cont.  
Mogul



Mogul  
Prefocus



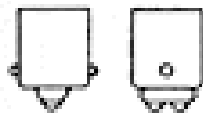
S-14s



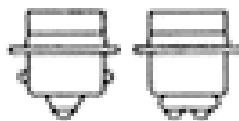
Mini  
Cand.



Cand.



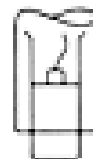
Cand.  
Bayonet  
SC/DC



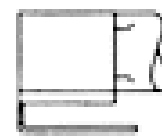
Cand.  
Prefocus  
SC/DC



Inter-  
mediate



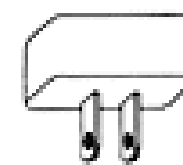
Recessed  
Single  
Cont.



Metal  
Sleeve  
Flex Lead



Medium  
Side  
Prong

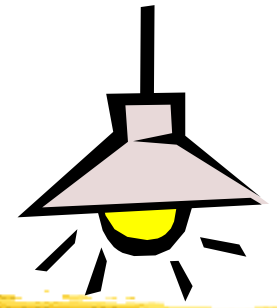


End  
Prong



Multi-  
purpose

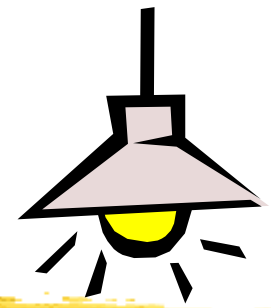
# Incandescent



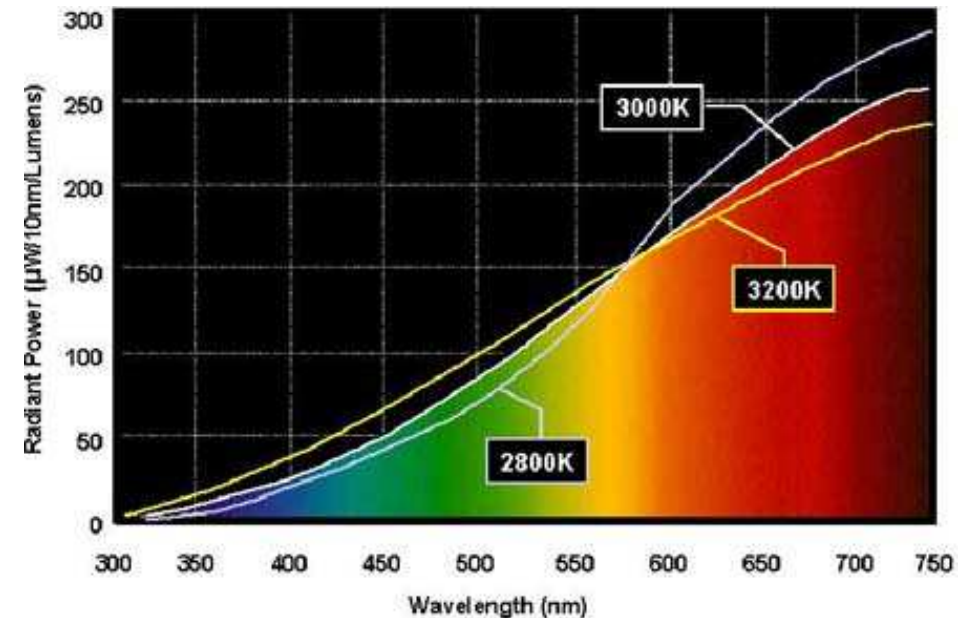
- Construction
  - Glass envelope
    - Lime glass, borosilicate (hard glass)
  - Fills
    - Vacuum, nitrogen, argon, krypton
  - Coatings
    - Acid etch, silica smoke, ceramic, paint
  - Basing
    - Aluminum, brass, nickel plated brass



# Incandescent



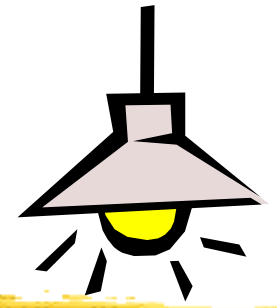
- Lamp characteristics
  - Colour temperature
  - Depreciation
  - Mortality
  - Life / lumens / colour / voltage relationships
  - Bulb & socket temperature



Spectral power distribution  
(incandescent)



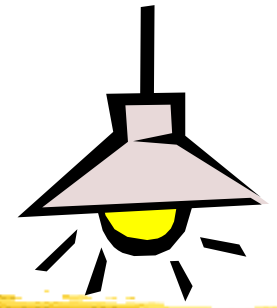
# Incandescent



- Major types of incandescent lamps
  - Standard general service (GLS)
  - Decorative
  - Rough service
  - Vibration service
  - Sign lamps
  - Indicator
  - Three way



# Incandescent



- Tungsten-halogen lamp, or quartz-halogen lamp (line voltage or low voltage)

- Advantages

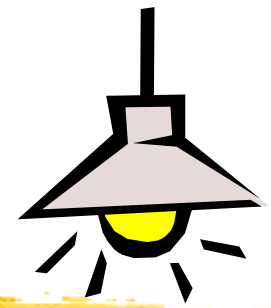
- Compact size
- Whiter light
- Excellent lumen maintenance
- Longer life

- Disadvantages

- More costly

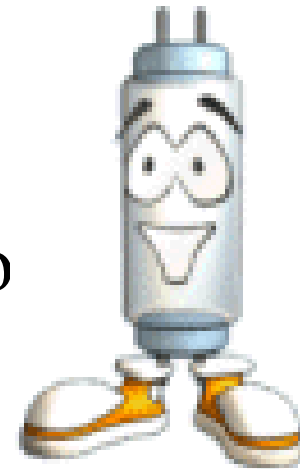


# Fluorescent



- Advantages

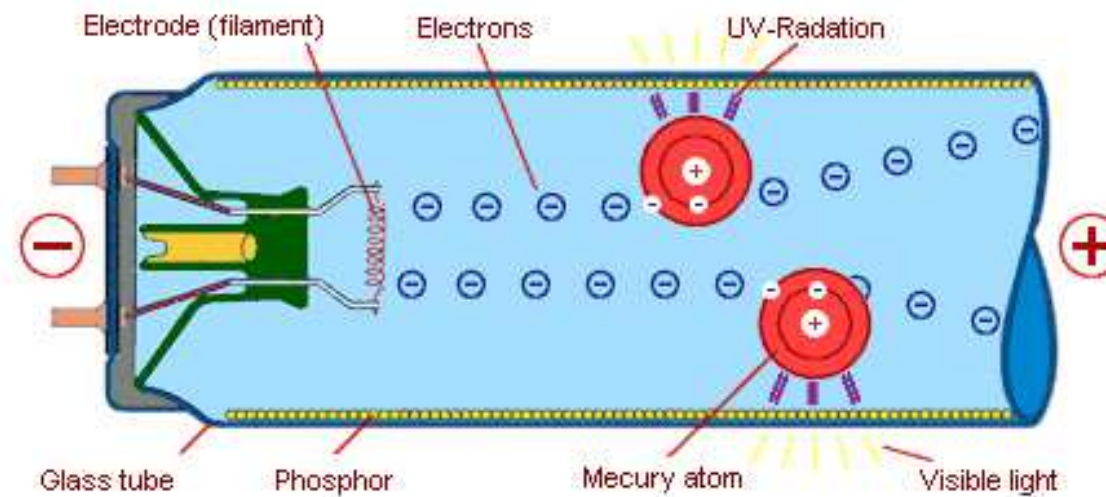
- High efficiency
- Super efficacy at high frequency operation
- Wide range of colour choices



- Disadvantages

- Require ballast
- Temperature sensitivity



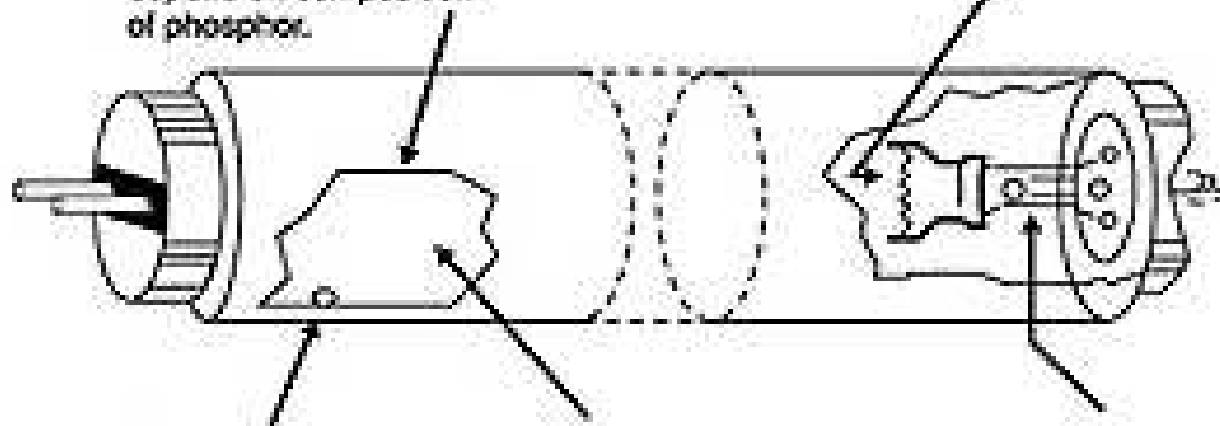


### Phosphor

Coating inside the bulb transforms ultraviolet radiation into visible light. Light color properties depend on composition of phosphor.

### Electrode

Electrodes at each end of lamp emits electrons. Usually made of single-coil tungsten wire.



### Mercury

A minute quantity of liquid mercury is placed in the bulb to furnish mercury vapor.

### Gas

Usually argon or a mixture of inert gases at low pressure. Krypton is sometimes used.

### Lead-In Wires

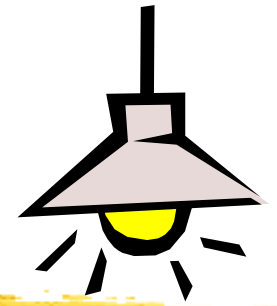
Connect to the base pins and carry the current to and from the electrodes and the mercury arc.



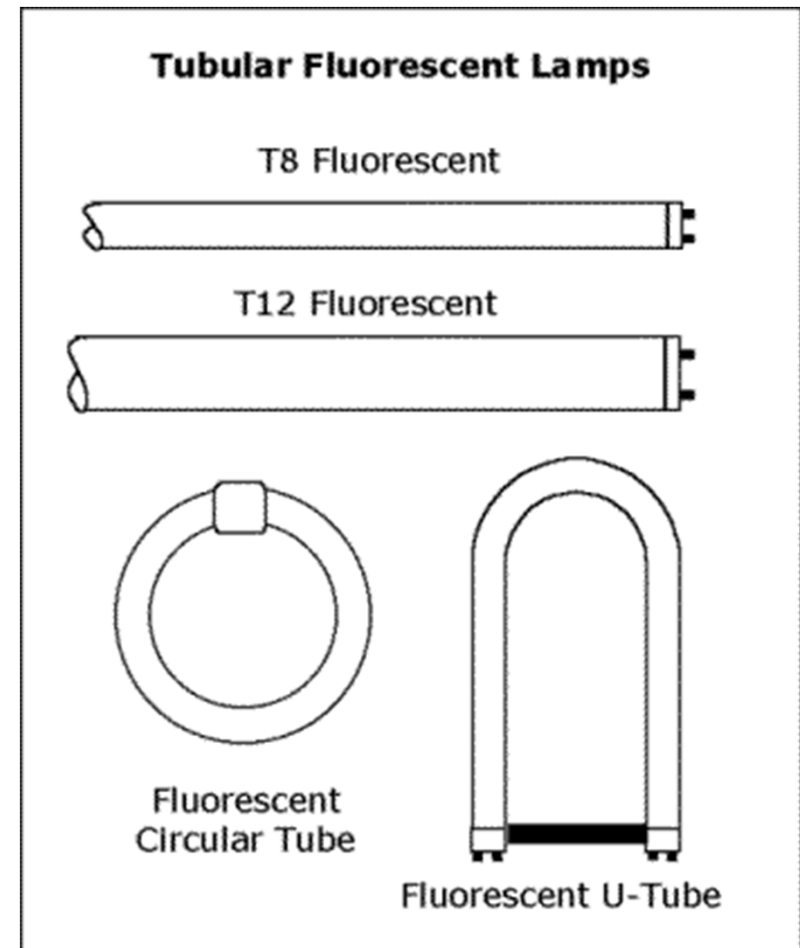
## Construction and operation of fluorescent lamp

(Source: LampTech, <http://www.lamptech.co.uk/> and <http://osram.no>)

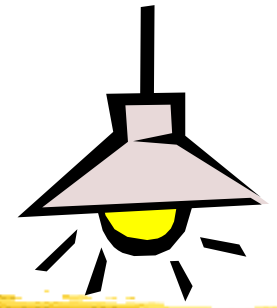
# Fluorescent



- Types of fluorescent lamps
  - Linear (tubular)
  - Compact
  - Circline
  - U shape
  - Subminiature
  - Reflector
  - Cold cathode



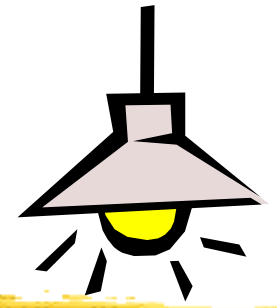
# Fluorescent



- Fluorescent lamp identification
  - Example: F30T12/CW/RS
    - "F" ... fluorescent
    - "30" ... rated nominal wattage
    - "T" ... tubular shape
    - "12" ... diameter in eighths of an inch;  $12/8 = 1.5$  in.
    - "CW" ... color; this lamp is a cool white lamp
    - "RS" ... mode of starting; rapid-start lamp

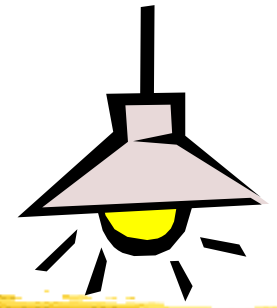


# Fluorescent



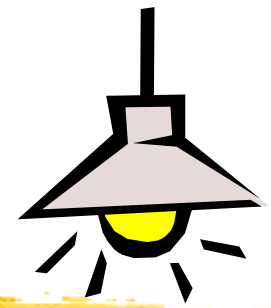
- Classification of fluorescent lamps
  - Lamp shapes
  - Lamp bases
  - Coating technology for (double- & tri-) Phosphor
- Lamp characteristics
  - Efficacy (longer the lamp, higher the efficacy)
  - Temperature effects
  - Strobe effect (flicker)
  - High frequency operation

# Fluorescent



- Operating characteristics
  - Light output vs. ambient temperature
    - Optimal at 25 °C (highest lumens per lamp)
    - Also affect the colour of the light produced
  - Lumen maintenance
    - Initial lumens decrease w/ operating hours
  - Effect of starting frequency on lamp life
    - Loss of the electron emissive coating on electrodes
    - Rated average life = based on 3 hrs operation per start

# Fluorescent



- Compact fluorescent

- Advantages

- Compact size
    - High efficacy
    - High CRI
    - Long life
    - Dimmable (some)
    - High frequency operation
    - Excellent lumen maintenance

- Disadvantages

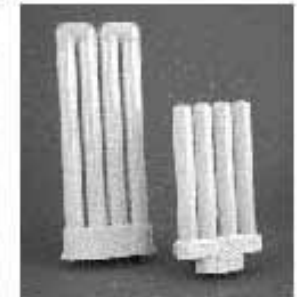
- Position sensitive
    - Thermal sensitivity
    - Require ballast
    - Higher initial cost (over incandescent)



Quad-lamp



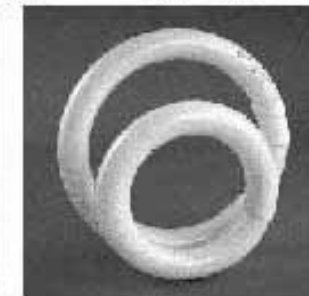
Triple-twin



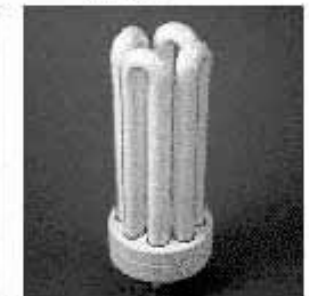
F-lamp



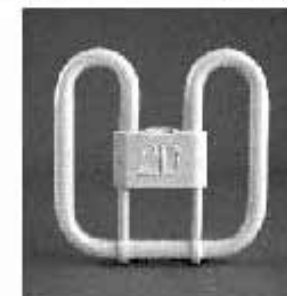
Twin-tube



Circline



Oct lamp

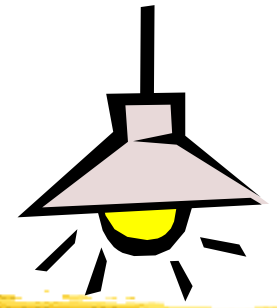


2-D

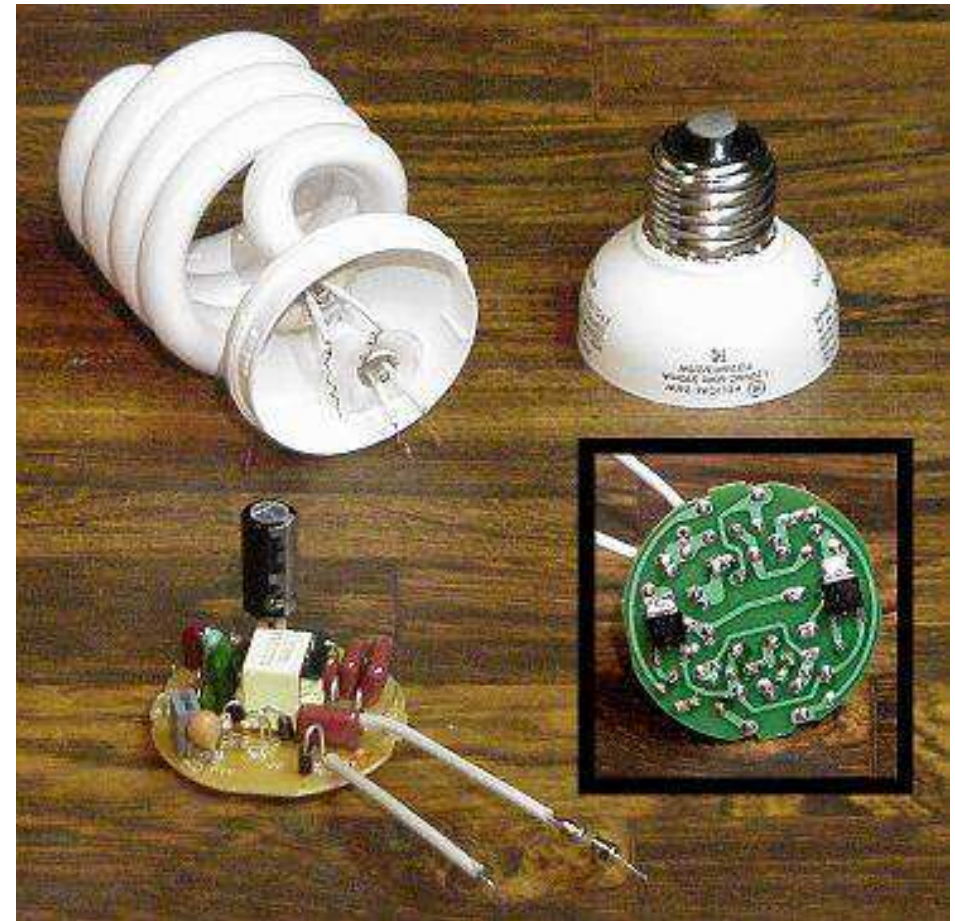


Helical

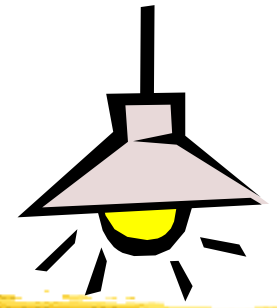
# Fluorescent



- Compact fluorescent
  - Types
    - Twin tubes
    - Quads
    - Triples
    - Globes
    - Reflectors
  - Adapter ballasts
  - Self-ballasted

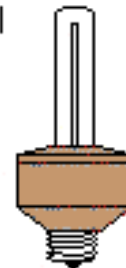


# Fluorescent

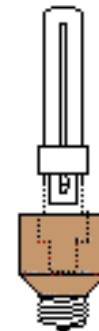


- Compact fluorescent
  - Thermal factor affecting light output & performance
  - Bulb wall temperature
    - Lamp positioning
    - Luminaire design (e.g. ventilation)
    - Plenum temperature
    - Ambient temperature
    - Amalgam temperature
  - Ballasting

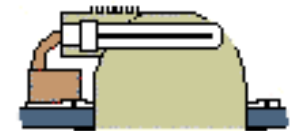
Integral



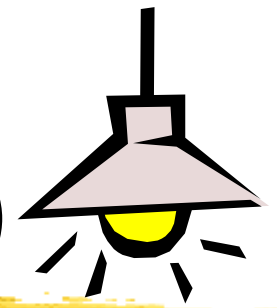
Modular



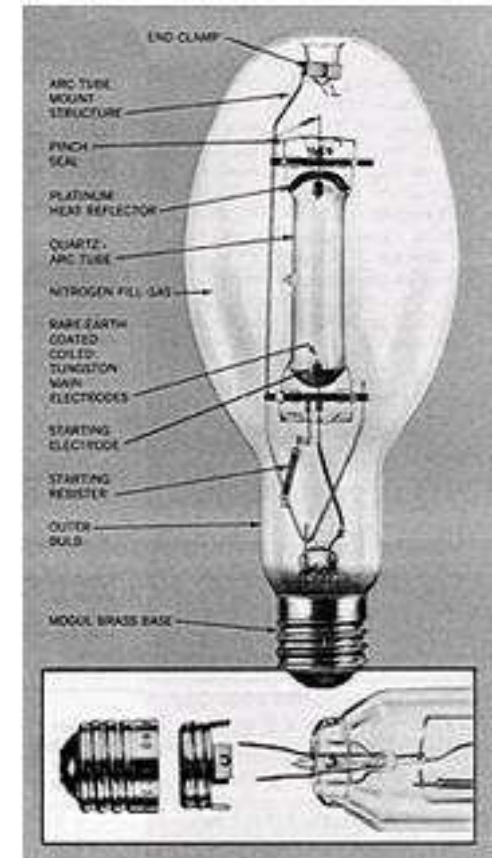
Dedicated



# High Intensity Discharge (HID)

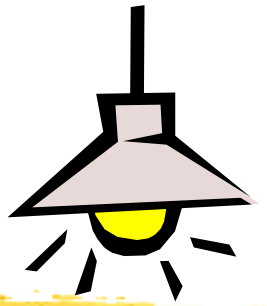


- High intensity discharge (HID)
  - Mercury vapour
  - Metal halide
  - High pressure sodium
- \* See example in LampTech website
  - <http://www.lamptech.co.uk/>



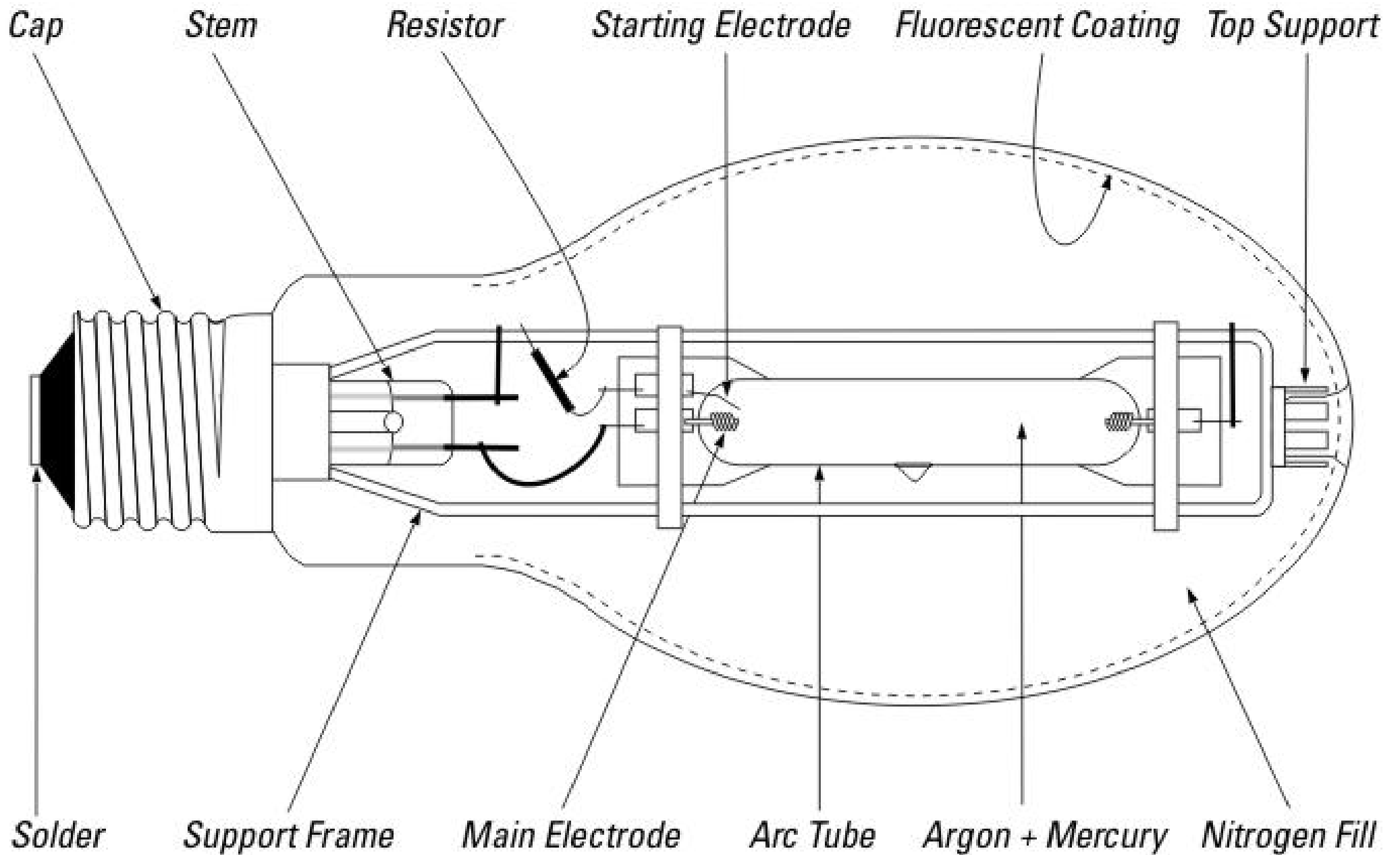


# High Intensity Discharge (HID)



- Mercury vapour
  - Advantages
    - Good for landscape lighting
  - Disadvantages
    - Lowest HID efficacy
    - Poor lumen maintenance
    - Poor colour
- (\* historical, use less nowadays)

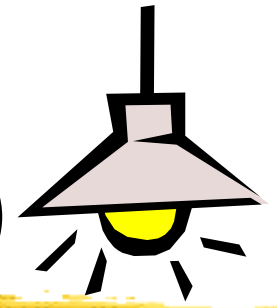




## Mercury vapour lamp

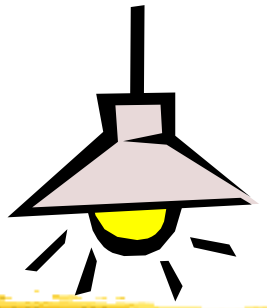
(Source: LampTech, <http://www.lamptech.co.uk/>)

# High Intensity Discharge (HID)



- Mercury vapour
  - Lamp types
    - Standard, PAR (parabolic), R (reflector), Safety
  - Operating characteristics
    - Starting characteristics
    - Lamp operating position (vertical/horizontal)
    - Lamp life & lumen maintenance
    - Temperature effects
    - Flicker & strobe

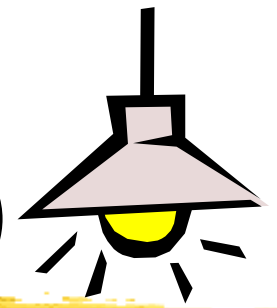
# High Intensity Discharge (HID)



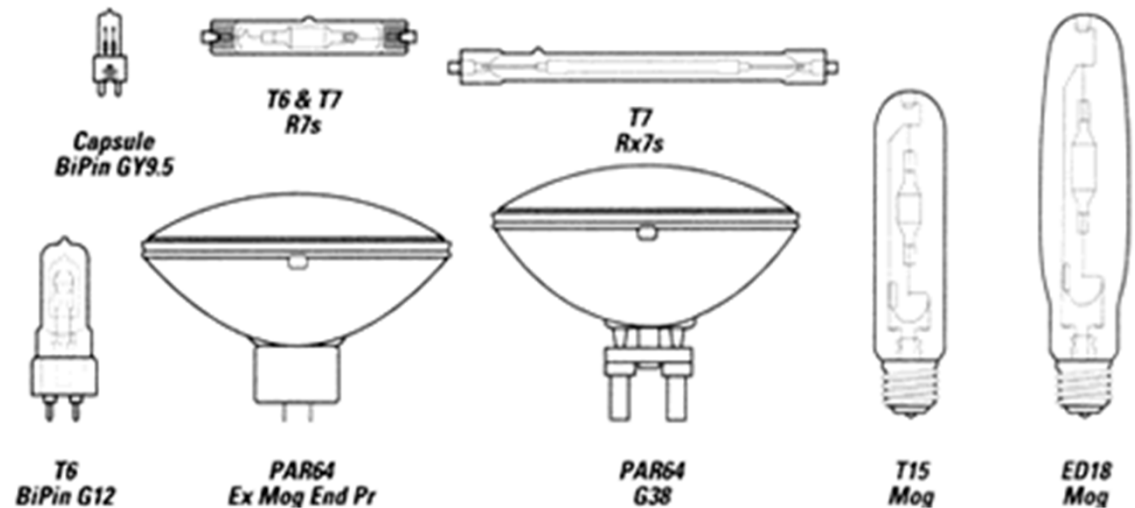
- Metal halide
  - Advantages
    - High efficacy
    - Good to excellent colour
    - Good lumen maintenance
    - Wide range of wattages
  - Disadvantages
    - Colour shift
    - Hot restrike time



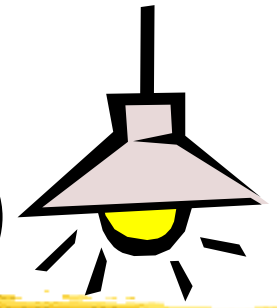
# High Intensity Discharge (HID)



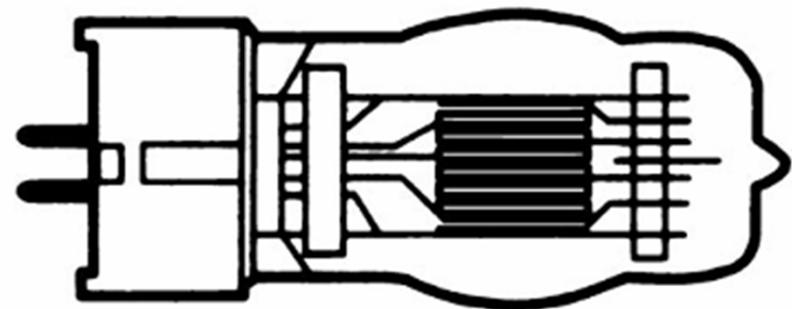
- Metal halide
  - Lamp types
    - Standard
    - High output
    - PAR (parabolic)
    - Open luminaires
    - Safety
    - Double ended



# High Intensity Discharge (HID)



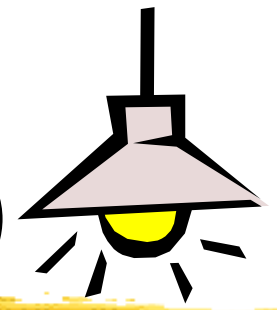
- Metal halide
  - Operating characteristics
    - Starting characteristics
    - Lamp operating position (vertical/horizontal)
    - Lamp life & lumen maintenance
    - Temperature effects
    - Flicker & strobe



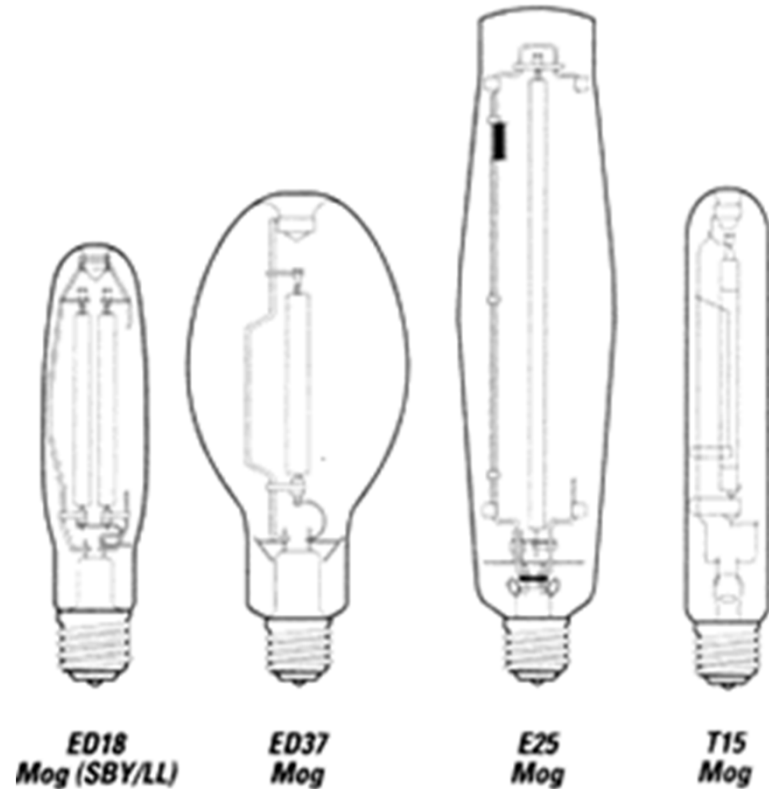
For theatre projection



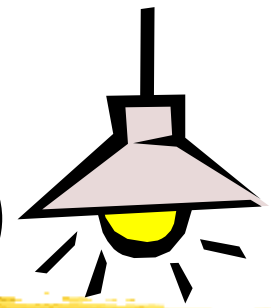
# High Intensity Discharge (HID)



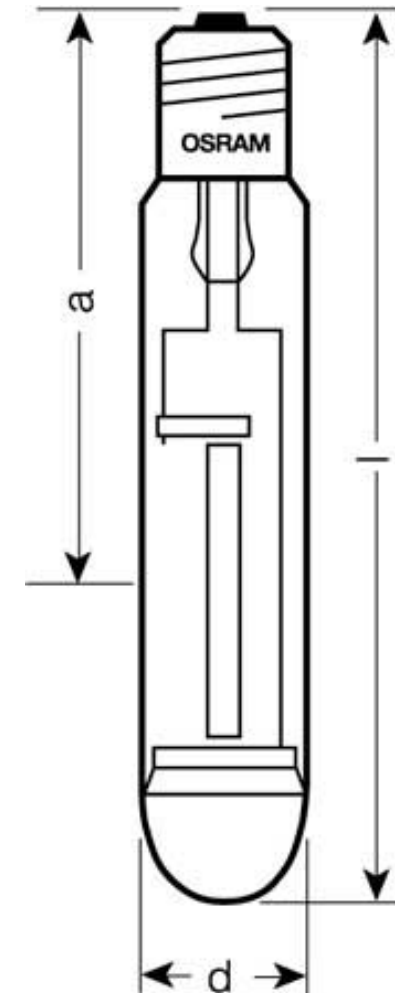
- High pressure sodium
  - Advantages
    - High efficacy
    - Long life
    - Universal burning position
    - Wide range of wattages
    - Good lumen maintenance
  - Disadvantages
    - Colour (standard lamp)
    - Require ballast
    - Cycling (standard lamp)



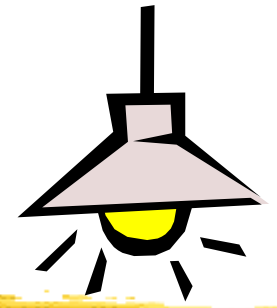
# High Intensity Discharge (HID)



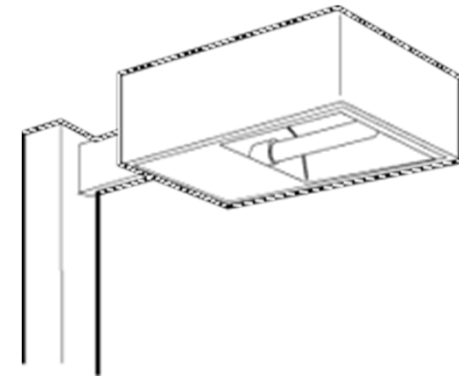
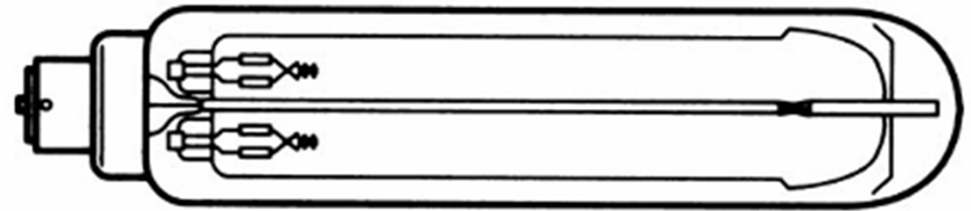
- High pressure sodium
  - Lamp types
    - Standard
    - Standby/instant restrike
    - High output
    - Non-cycling
    - Deluxe colour
    - Double ended
    - Self-ballasted
    - Mercury retrofit
  - Operating characteristics
    - Starting characteristics
    - Lamp operating position (vertical/horizontal)
    - Lamp life & lumen maintenance
    - Temperature effects
    - Cycling

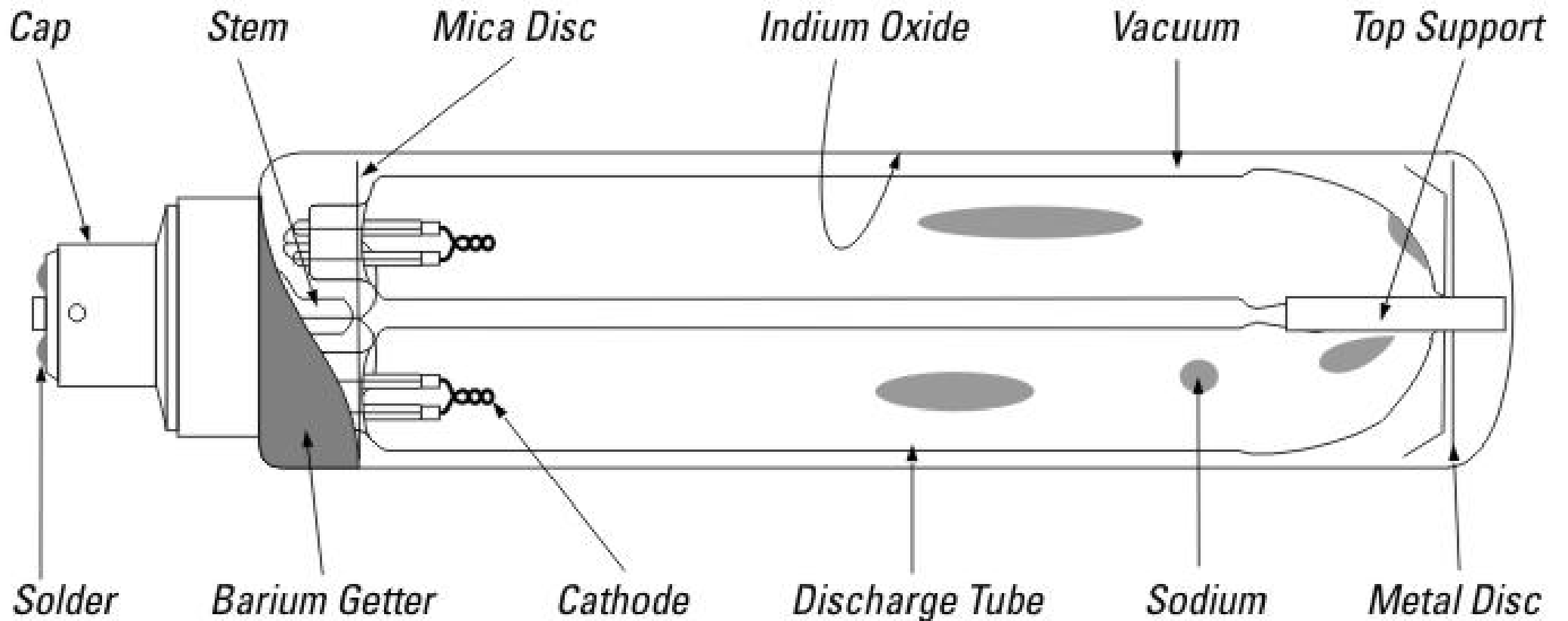


# Low Pressure Sodium



- Low pressure sodium
  - Advantages
    - Highest efficacy
    - Hot restrike
  - Disadvantages
    - Monochromatic
    - Optical control
    - Lamp disposal
    - Increased wattage over life

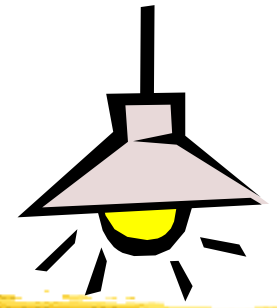




## Low pressure sodium lamp

(Source: LampTech, <http://www.lamptech.co.uk/>)

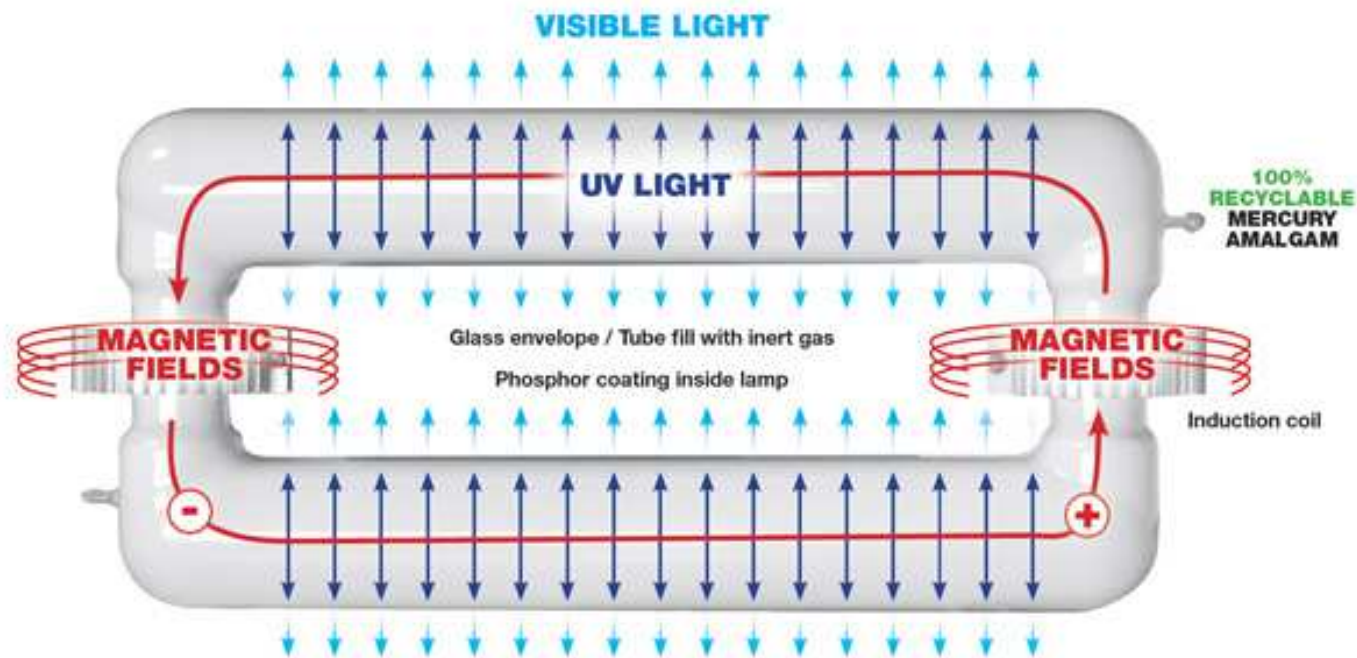
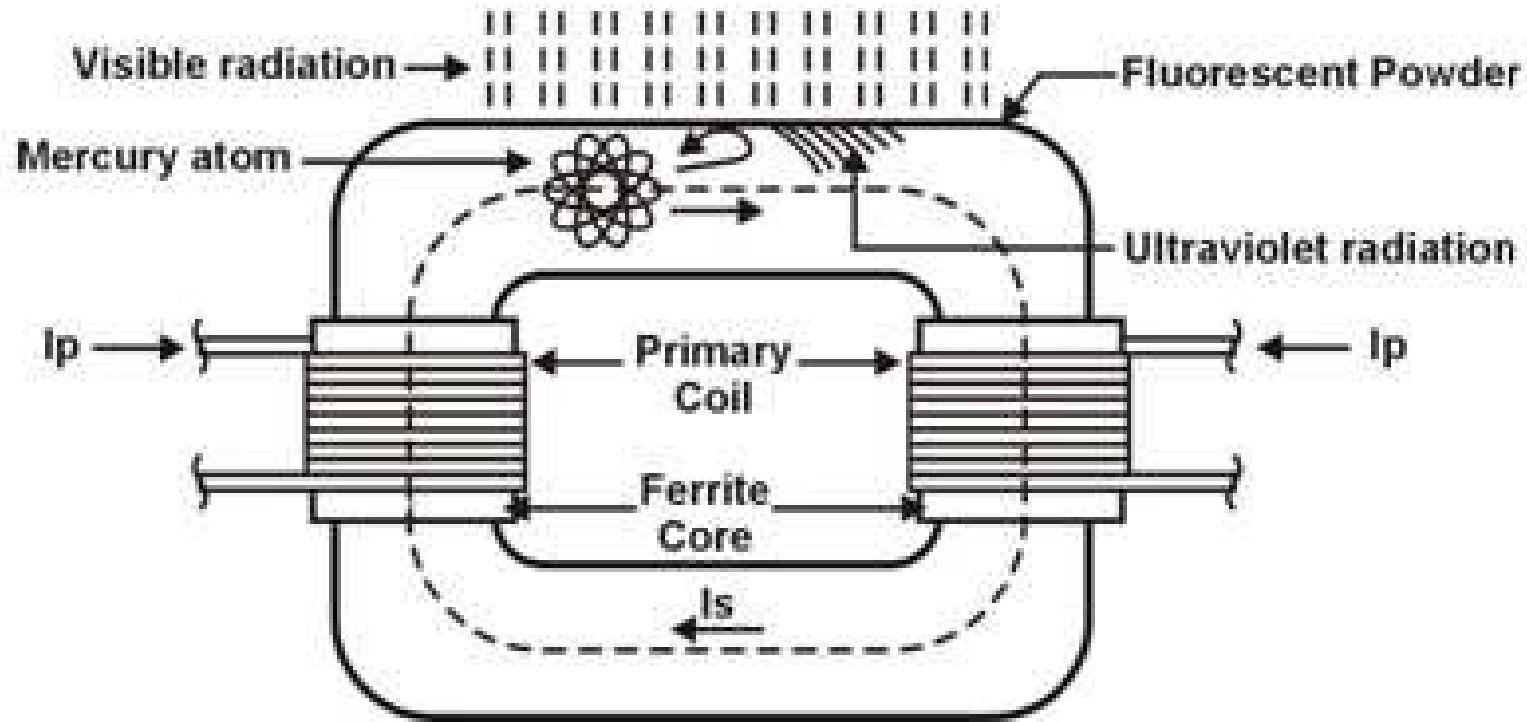
# Induction Lamps



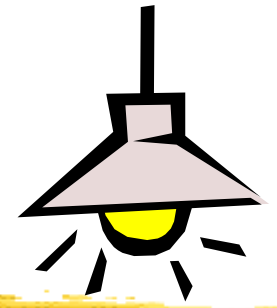
- They are gas discharge lamps that do not have electrodes
- The electric field in the lamp is induced by an induction coil that is operating at high frequency



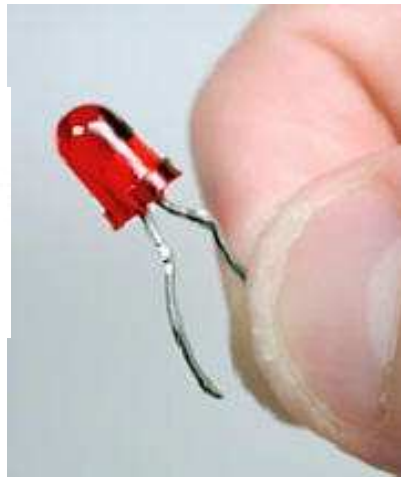
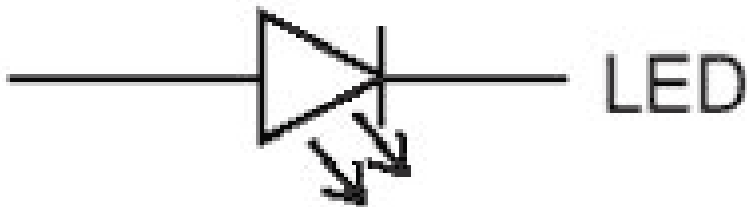
# Induction lamps based on fluorescent lamp technology



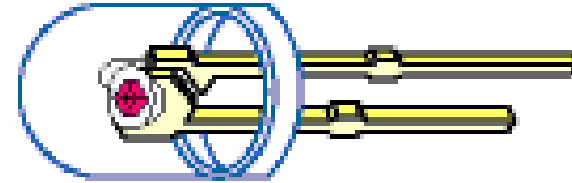
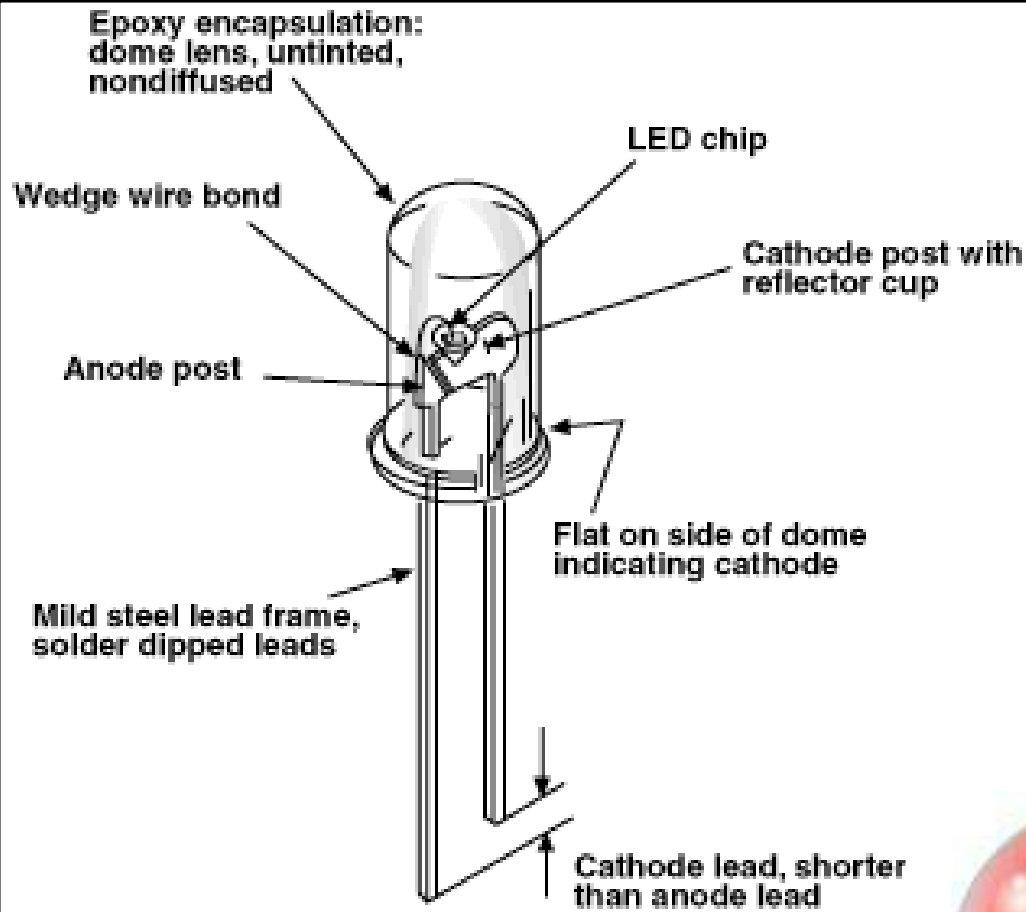
# Light Emitting Diode (LED)



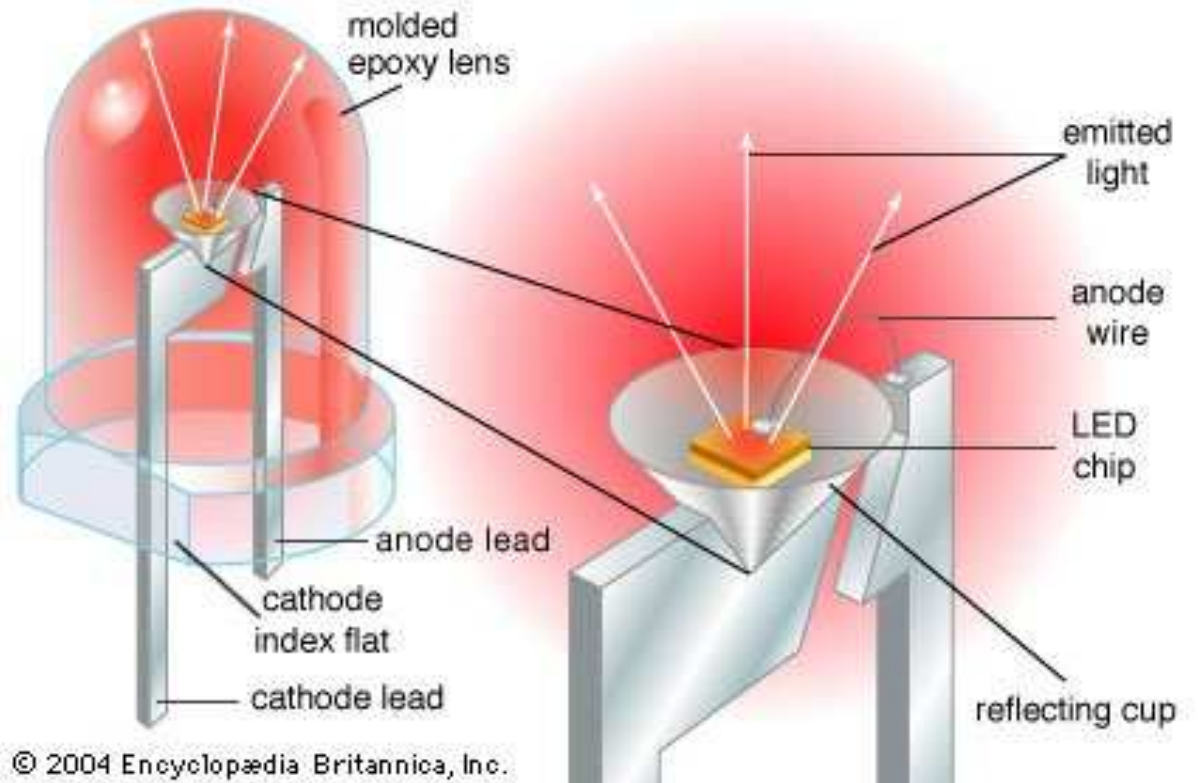
- Light emitting diode (LED)
  - Produces light by electroluminescence at low voltage “p-n” junction (e.g. indicator lights)
  - Development of white light & high output LEDs enables wider use in lighting systems





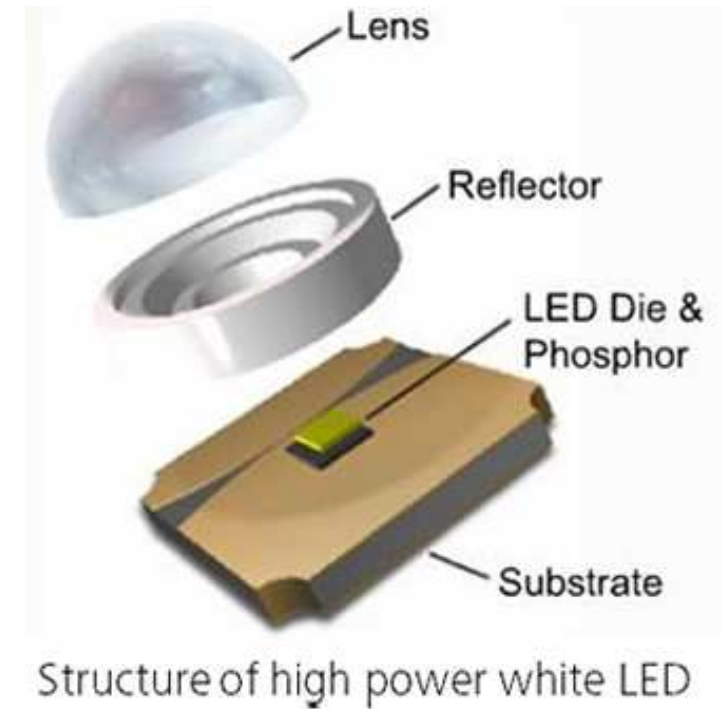
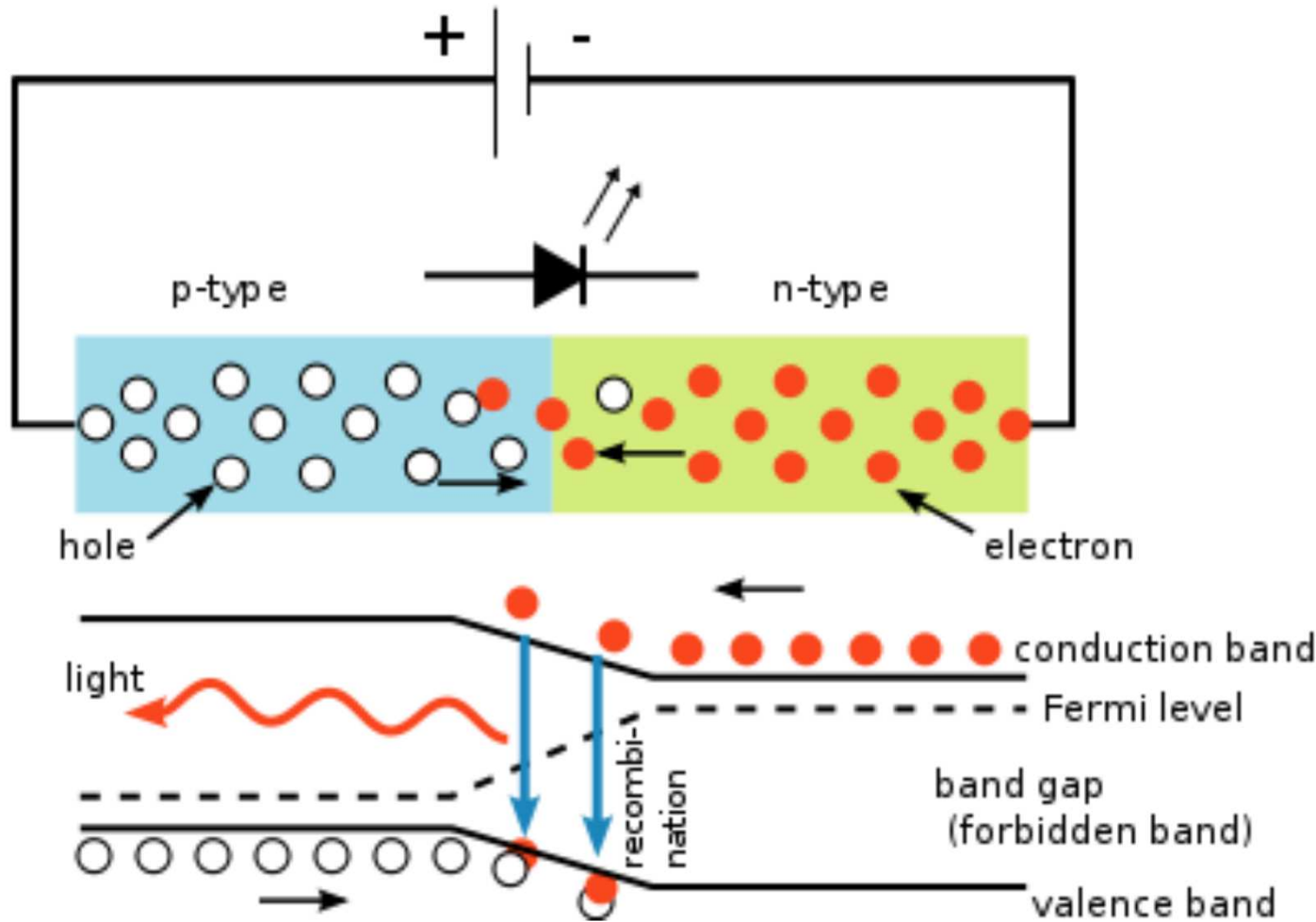


**Figure 1. The anatomy of a plastic, T-1<sup>3/4</sup> TS AlInGaP LED lamp**





# Principle of LED and structure of high power white LED\*



Structure of high power white LED

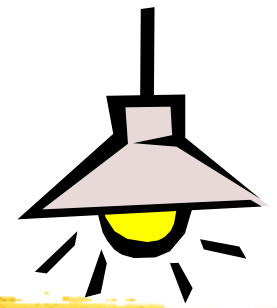


(\* See How LED Works, <http://www.omslighting.com/ledacademy/>)



Examples of LED lamp application

# Light Emitting Diode (LED)



- Light emitting diode (LED)

- Advantages

- Low power consumption
    - Long lasting (long useful life)
    - Durable (withstand impact & vibration)
    - Cool (little heat produced)
    - Modular design & compact size
    - Controllability (colour balance & intensity)
    - Instant on, frequent switching
    - No annoying flicker
    - Low cost of manufacture
    - No ultraviolet & infrared radiation
    - Mercury free

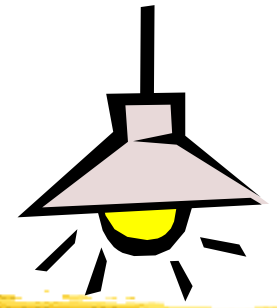
- Disadvantages

- Focused, directional light
    - Need different optics design
    - May need heat sink (thermal management)

LED candles



# Light Emitting Diode (LED)

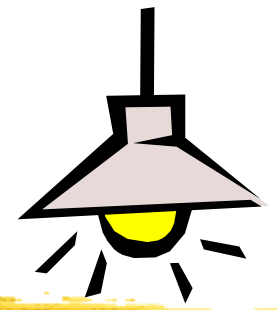


- Solid state lighting (SSL)
  - Emits light from semi-conductor (solid)
    - Light emitting diode (LED)
    - Organic light-emitting diodes (OLED)
    - Polymer light-emitting diodes (PLED)
  - Advantages:
    - Low power consumption
    - Reduced heat generation
    - Greater resistance to shock, vibration, and wear
  - LED retrofits (not ideal), versus LED luminaires





# Light Emitting Diode (LED)

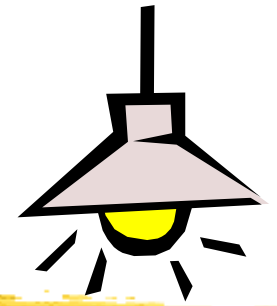


- Video: LEDs and OLEDs - How it Works, Inventors (7:18)



- <http://www.youtube.com/watch?v=8quZrUcRFlw>
- All about Light Emitting Diodes and Organic LEDs. How they work, the difference between them.
- Learn about the inventors of the lights at the end of the program.

# Ballasts

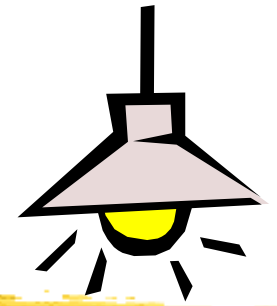


(\* See also [http://en.wikipedia.org/wiki/Electrical\\_ballast](http://en.wikipedia.org/wiki/Electrical_ballast))

- Ballasts\* (e.g. electromagnetic and electronic ballasts)
  - For operation of gas discharge lamps (e.g. fluorescent, HID)
  - Provide several functions:
    - Deliver proper voltage to start or ignite the lamp(s)
    - Current limiting (to safely sustain operation)
    - Compensate for variations in line voltage
    - May offer electrode preheat, dimming or power quality adjustment
  - Consume power & reduce overall lumens per watt rating
  - Ballast factor (BF) (range from 0.7 to 1.2)
    - It is a measure of actual lumen output for a specific *lamp-ballast* system relative to the rated lumen output measured with a reference ballast under test conditions

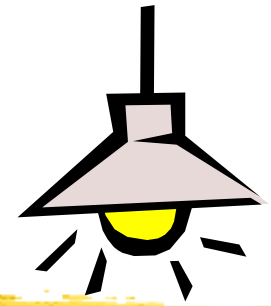


# Ballasts



- Ballast efficacy factor (BEF)
  - = Ballast factor (BF) x 100 / Input Watts
- Harmonics caused by electronic ballasts
  - Switching techniques in solid-state electronic ballasts may cause line current harmonics
  - Total harmonic distortion (THD)
    - Distorted wave from superimposing harmonic sine waves (multiples of the fundamental)
  - Consequences of harmonics:
    - Contribute to resistive heating in wiring, insulation, etc
    - Cause lower power factors
    - Produce overheating in transformers
    - Cause excessive current in neutral conductor

# Luminaire



- Luminaire (light fixture)

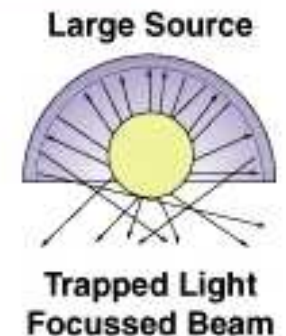
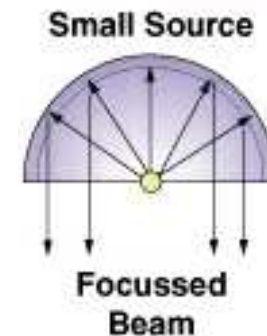
- A complete lighting system:

- A housing and lampholders
- Lamps (w/ a ballast/transformer)
- Optical system

- Reflector, and either a lens, louver or diffuser
- For controlling brightness

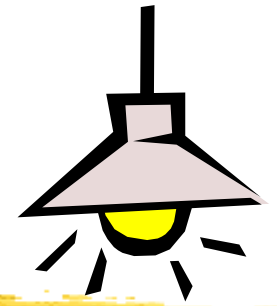
- It may also include some type of electrical control dimmers, hilo switching, daylight sensors, etc.

## IDENTICAL REFLECTORS



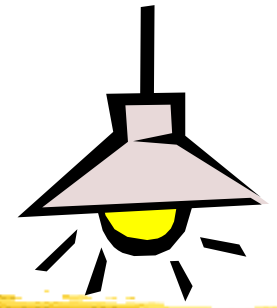


# Luminaire

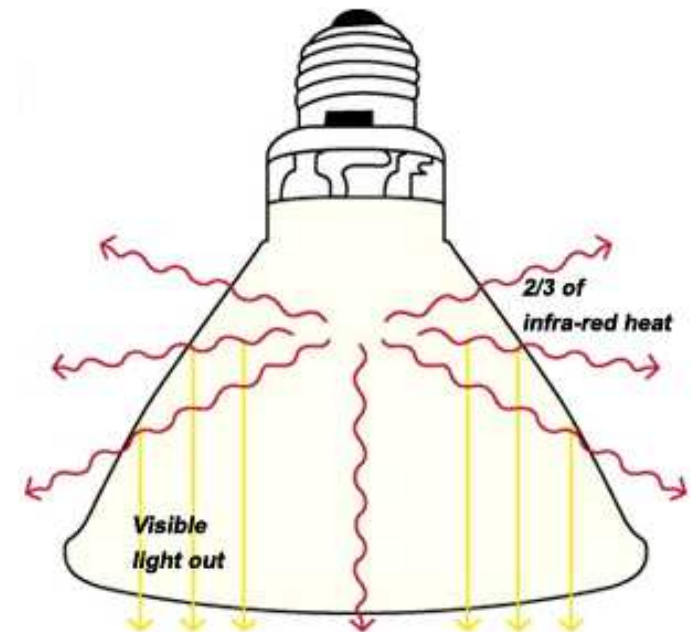
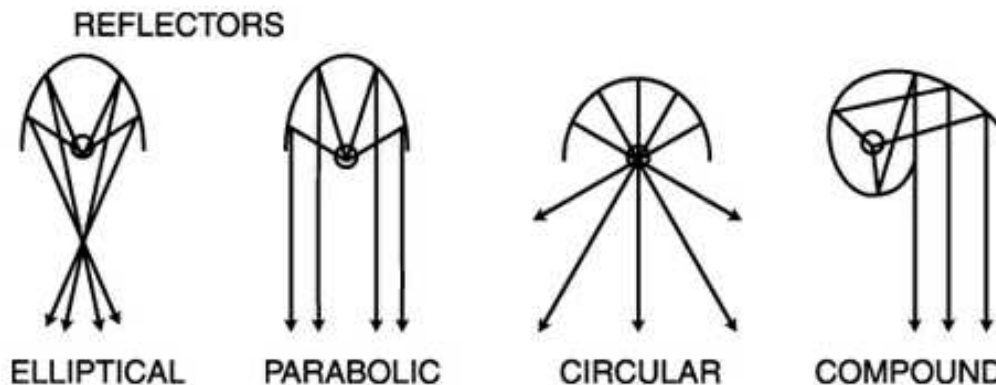


- Six basic classifications of luminaires:
  - Direct luminaire where all the light is directed down
  - Semi-direct luminaire where the majority of the light is directed down
  - General diffuse luminaire where light is distributed in all directions
  - Direct-indirect luminaire where light is distributed equally up and down
  - Semi-indirect luminaire where the majority of light is directed up
  - Indirect luminaire where all the light is directed up

# Luminaire



- Optical systems
  - Typical methods of controlling light
    - Reflection
      - Specular, diffuse, spread, selective
    - Transmission
      - Direct, diffuse, spread, selective
    - Refraction



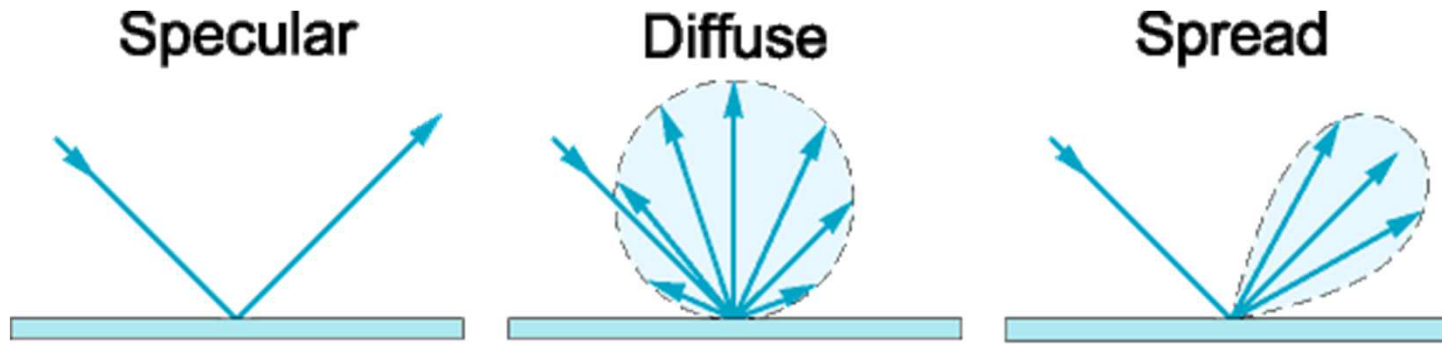


Fig. 3.2 Specular, diffuse, and spread reflection from a surface.

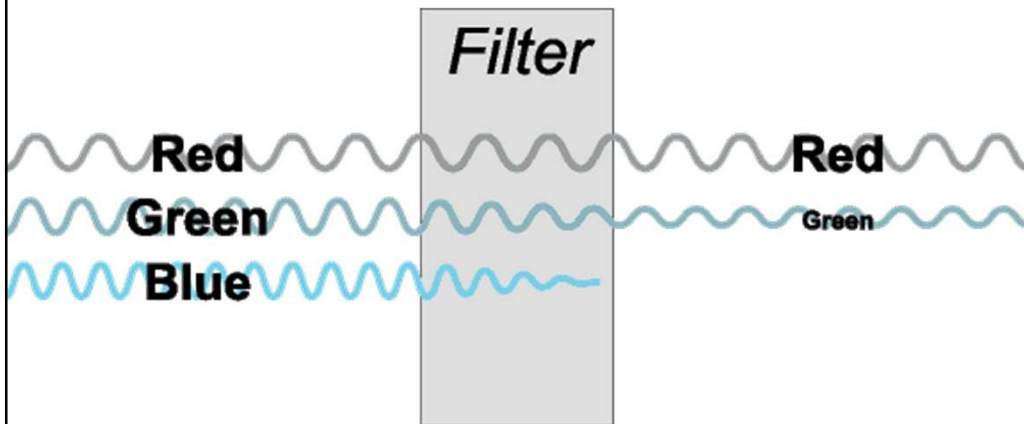


Fig. 3.3 Transmission through an optical filter.

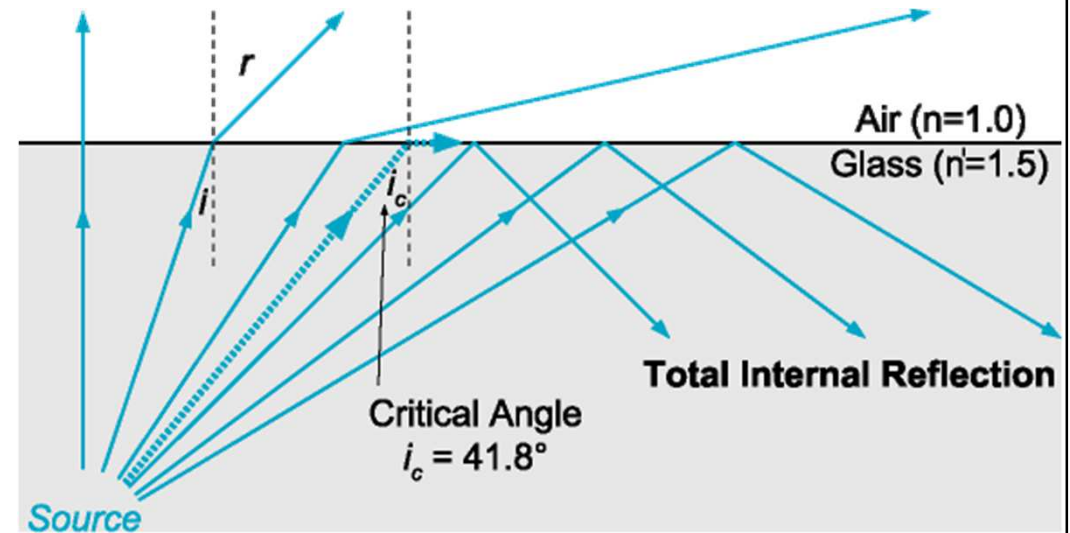
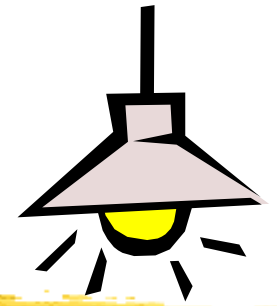


Fig. 3.5 Refraction and total internal reflection.

Methods of controlling light  
 (Source: IESNA Handbook 9th ed.)

# Luminaire

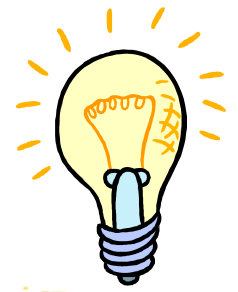


- Luminaires Efficacy Rating (LER)
  - $LER = (\text{Photometric Efficiency} \times \text{Total Lamp Lumens} \times \text{Ballast factor}) / \text{Luminaire Input Watts}$
- How to classify fluorescent luminaires & systems
  - Mounting: recessed, surface (ceiling or wall) & suspended
  - Distribution: direct, indirect, direct/indirect
  - Type of fluorescent lamp: T12, T8, T5
  - Nominal dimensions: 1 x 4, 2 x 4, etc
  - Application: commercial, industrial, residential, special purpose



# Further Reading

- The Electric Light (Edison Tech Center)  
<http://www.edisontechcenter.org/Lighting.html>
- Incandescent Lamps  
<http://www.edisontechcenter.org/incandescent.html>
- The Fluorescent Lamp  
<http://www.edisontechcenter.org/Fluorescent.html>
- Mercury Vapor Lamps  
<http://www.edisontechcenter.org/MercuryVaporLamps.html>
- Metal Halide Lamps <http://www.edisontechcenter.org/metalhalide.html>
- Sodium Lamp <http://www.edisontechcenter.org/SodiumLamps.html>
- LEDs and OLEDs <http://www.edisontechcenter.org/LED.html>



# Further Reading

- SLL, 2009. *The SLL Lighting Handbook*, Society of Light and Lighting (SLL), Chartered Institution of Building Services Engineers, London.
  - Chapter 3: Light sources
  - Chapter 4: Luminaires
  - Chapter 5: Electrics