

Assignment 01: BIM for Conceptual Design and Analysis

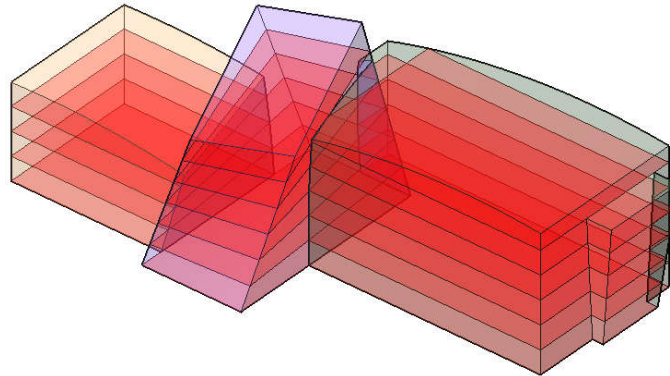

Building information modelling (BIM) can be used in conceptual design phase to explore ideas and perform early analyses for a building project. During the early planning stages of a building project, building designers can analyze the conceptual design in several ways and for various purposes. Typical studies and analyses include:

(a) Massing studies

- Explore design ideas by using shapes to conceptualize a building model.
- Establish and visualize building forms, shadows and contextual information.

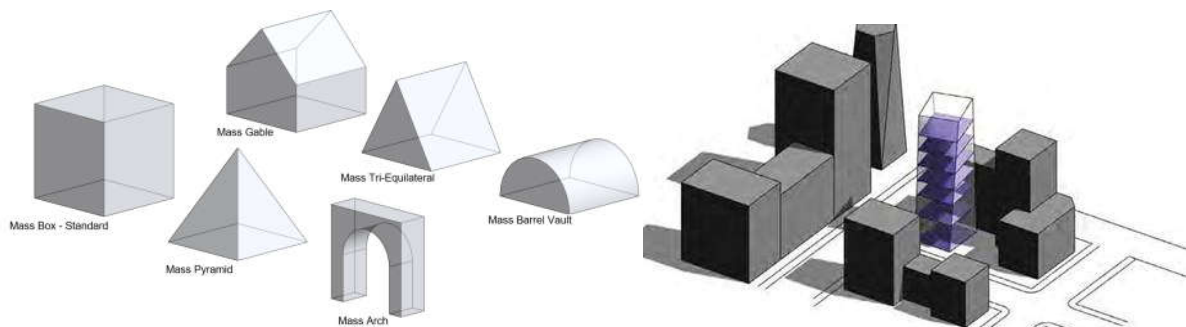

(b) Building performance (physics) analyses

- Examine building performance issues such as sun, light, wind, energy and comfort.
- Evaluate shading effects, window design, daylighting, solar photovoltaic generation, ventilation strategies, thermal loads, building energy use and thermal comfort.

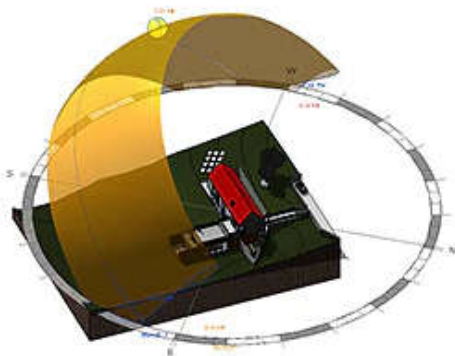

(Image source: Autodesk)

Objectives of this assignment

- To appreciate the building design and analysis techniques in conceptual design phase.
- To apply BIM and other software for massing studies and building physics analysis.
- To learn how to document the analysis results in a concise and systematic way.

Methodology

Each student should select a practical situation of a generic building project in conceptual design phase in order to demonstrate the use of massing studies and building performance analysis. The current functions and plug-in features of Autodesk Revit can be applied to carry out the studies and analyses. For example,

Under the “*Massing & Site*” menu:

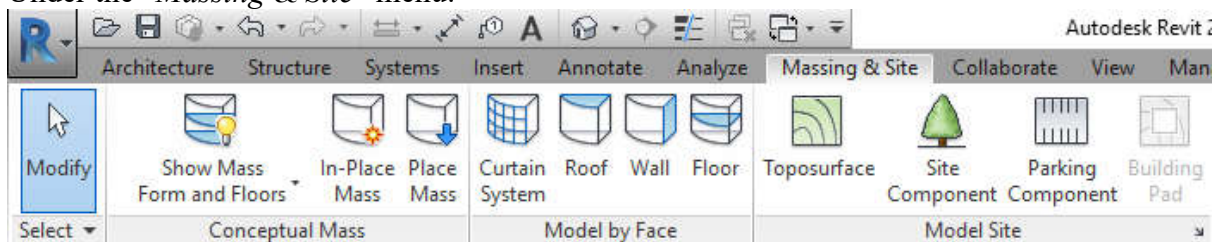

Under the “*Analyze*” menu:

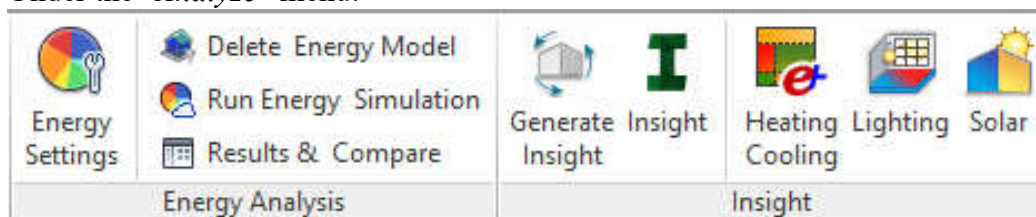

Students may make use of other software (such as SketchUp, 3ds Max and Form/Z) to prepare the 3D elements and then import the geometry to Revit. They may also apply other analysis tools or software to support the building performance analyses (such as solar studies, overshadowing and daylight analysis).

Submission

Each student should complete the massing studies and building performance analyses in an effective manner and then document the results in a concise and systematic way. The submission should include clear description of the building model, design ideas and options, intention of the massing studies and building performance analyses, as well as key summaries of the analysis results. The description should be neat and properly written and organized to communicate your findings. Proper credit and referencing should be provided to the information sources. Students making direct copy of the information in other publications or sources (plagiarism), if found, will be disqualified.

The documentation and related details (contained in appendices) should be submitted through the Moodle system. Normally the submission file should not be more than 30 nos. A4 pages. The assessment criteria include clarity of the information, quality of the content, report organization and writing skills. Submission deadline: **on or before 20 Mar 2019 (Wed)**

Resources

Massing studies:

12 tips for efficient conceptual massing

http://www.extensionmedia.com/basecamp/1289422/augiaecedgesummerseptemberissue/BOWLES_12TIPS_v1.pdf

Mass Modeling (Revit Architecture)

[http://wiki.bk.tudelft.nl/toi-pedia/Mass_Modeling_\(Revit_Architecture\)](http://wiki.bk.tudelft.nl/toi-pedia/Mass_Modeling_(Revit_Architecture))

Massing - Wikipedia <https://en.wikipedia.org/wiki/Massing>

Massing In Revit <https://prezi.com/wps9yqi51tmi/massing-in-revit/>

Massing Studies (Autodesk)

<http://help.autodesk.com/view/RVT/2018/ENU/?guid=GUID-B8858693-F46D-4211-8C-CC-B5E88681C466>

Building performance analysis:

Conceptual Design and Analysis: BIM in High Gear

<https://www.slideshare.net/Array-Architects/conceptual-design-and-analysis-bim-in-high-gear>

Energy Optimization for Revit (Autodesk)

<http://help.autodesk.com/view/RVT/2018/ENU/?guid=GUID-2043E09F-40E5-4155-AE28-134F62E54F54>

Insight: building performance analysis software (Autodesk)

<https://www.autodesk.com/products/insight/overview>

Software for sun & daylight analyses (by Dr Andrew Marsh)

<http://andrewmarsh.com/software/>

- 2D Sun-Path <http://andrewmarsh.com/software/sunpath2d-web/>

- 3D Sun-Path <http://andrewmarsh.com/software/sunpath3d-web/>

- Dynamic Overshadowing <http://andrewmarsh.com/software/shading-box-web/>

- Dynamic Daylight <http://andrewmarsh.com/software/daylight-box-web/>

Solar Studies (Autodesk)

<http://help.autodesk.com/view/RVT/2018/ENU/?guid=GUID-F68D32C9-0391-4115-95C5-90DCD115426A>

References

de Wilde, P., 2018. *Building Performance Analysis*, Wiley Blackwell, Hoboken, NJ.

Kensek, K. M. and Noble, D., 2014. *Building Information Modeling: BIM in Current and Future Practice*, Wiley, Hoboken, NJ. (ebook)

- Chapter 7 - Energy Modeling in Conceptual Design

Krygiel, E. and Nies, B., 2008. *Green BIM: Successful Sustainable Design with Building Information Modeling*, Wiley, Indianapolis, IN. (ebook)

- Chapter 5 - Sustainable BIM—Building Form

- Chapter 6 - Sustainable BIM—Building Systems