



Analysis of Building Services Systems



Dr. Sam C. M. Hui

Department of Mechanical Engineering

The University of Hong Kong

E-mail: cmhui@hku.hk

Contents



- Overview
- Ventilation Strategy
- Displacement Ventilation
- Chilled Ceiling
- Lighting Control

Overview

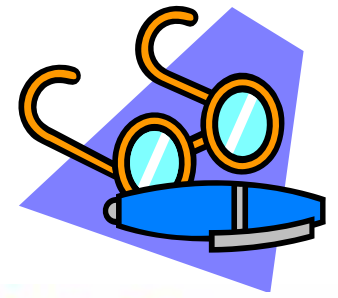

- Building services systems being controlled
 - **HVAC** (heating, ventilation & air-conditioning)
 - Fire services
 - Plumbing & drainage
 - Electrical installations
 - Lighting
 - Lifts & escalators
 - Security & communication
 - Special systems e.g. medical gas

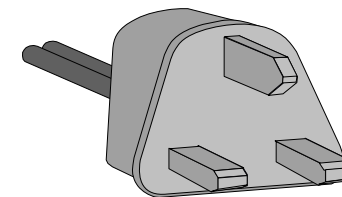
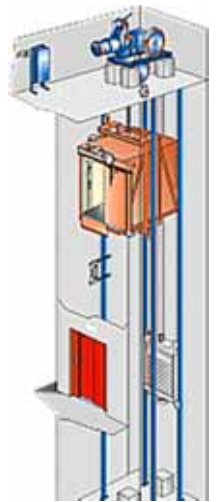
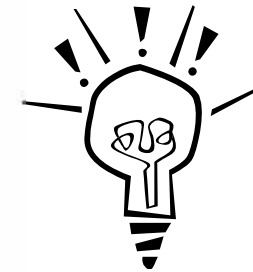
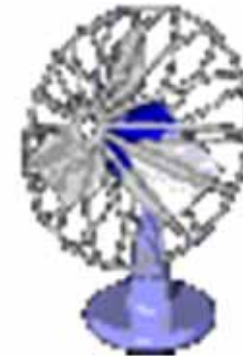

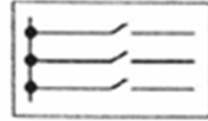

Electrical installation



Blinds and shutters



Ventilation



Air conditioning

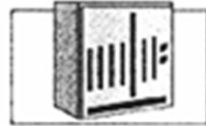

Switchgear and controlgear



Stand-by power supply

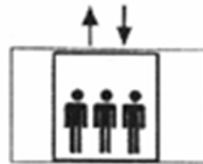

Elevator



Security

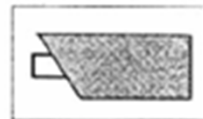

Video



Office and data systems technology



Telephone



Waste disposal

Building Services Systems

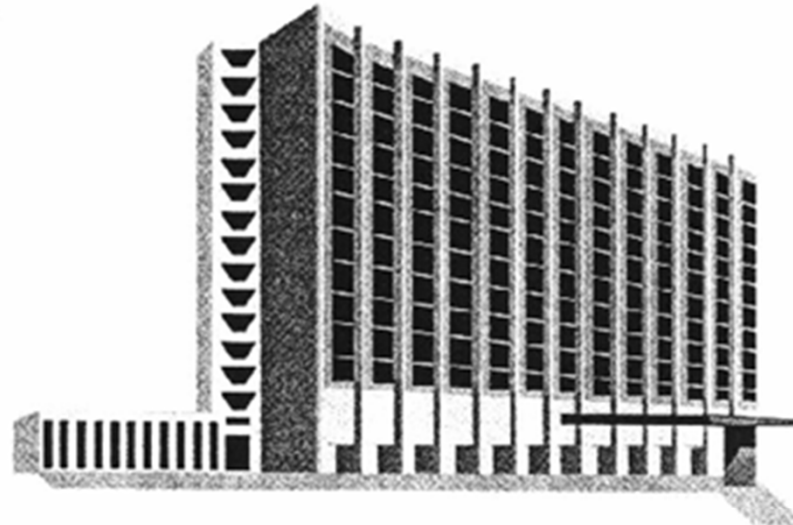

Heating



Cooling



Sanitation



Lighting

Examples of control systems and devices in buildings

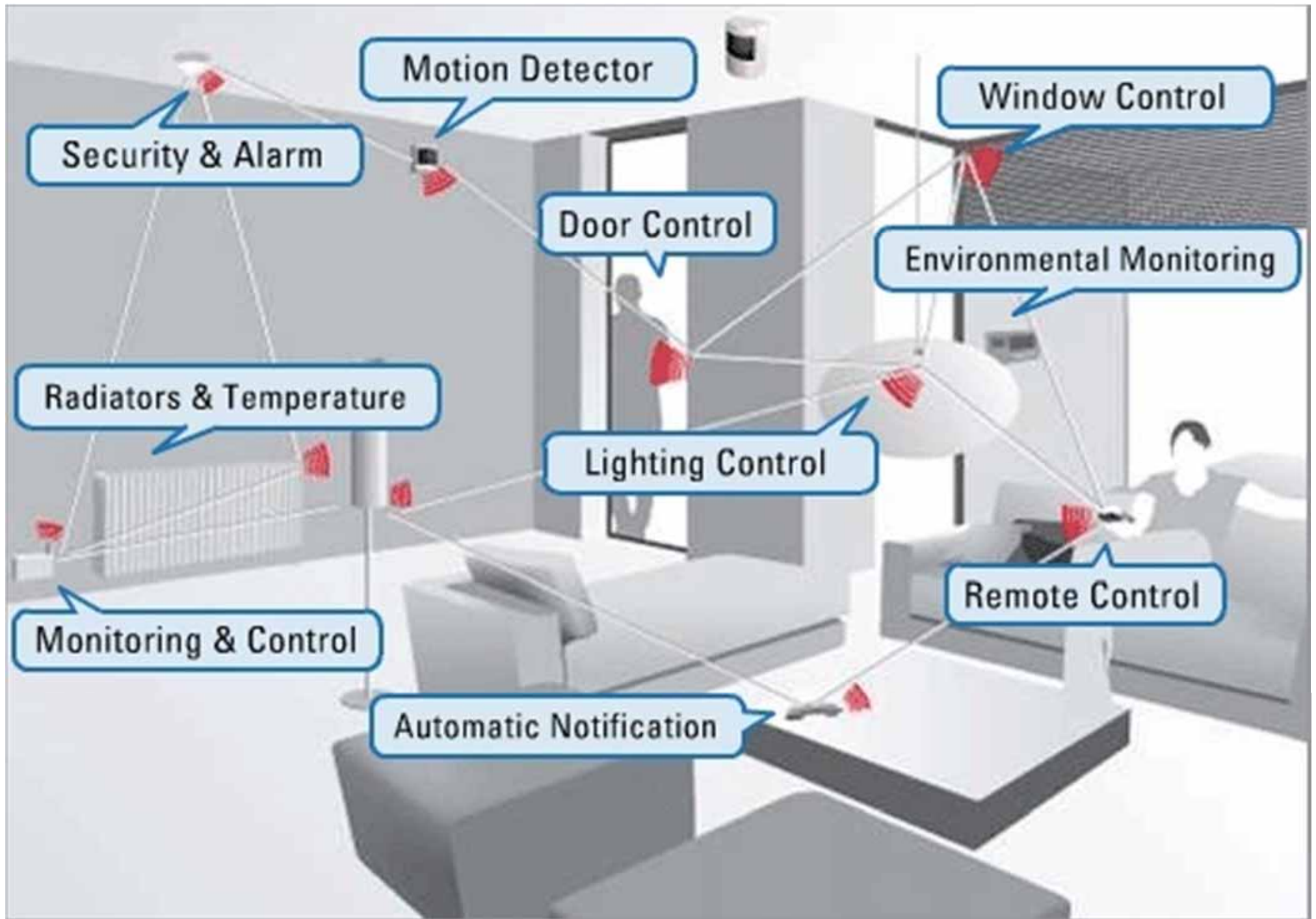

Networked building systems offer remote control capabilities

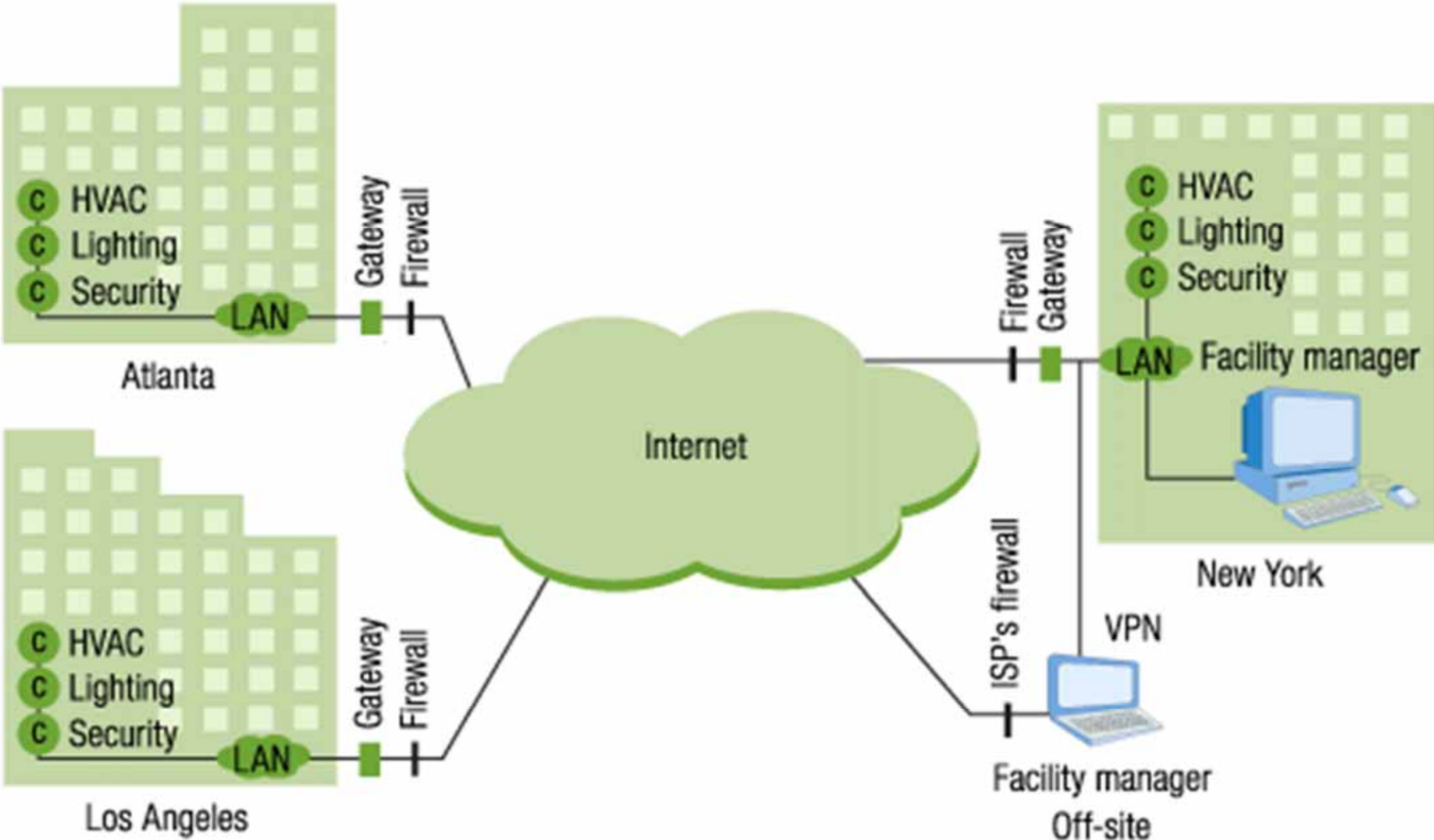

Notes: ISP = Internet service provider; LAN = local area network;
VPN = virtual private network.

© E Source

[Source: E Source]

Overview

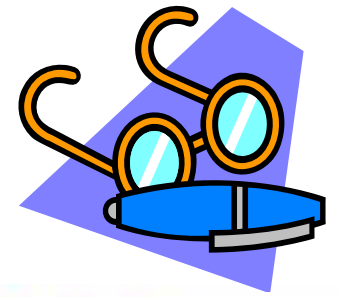

- Examples of low-energy air conditioning and lighting control*
 - 1. Mixed mode or hybrid ventilation
 - 2. Displacement ventilation
 - 3. Chilled ceiling
 - 4. Lighting control

[* See also: Levermore, G. J., 2000. *Building Energy Management Systems: Application to Low-energy HVAC and Natural Ventilation Control*, 2nd ed., Chp. 12, E & FN Spon, London & New York.]

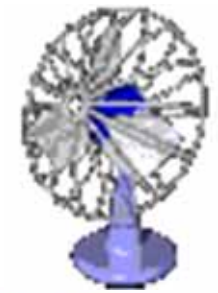

Ventilation Strategy

- A primary goal when designing high performance energy efficient buildings is to eliminate or reduce the need for cooling or heating equipment
- This may not be possible in severe cold or hot climates, but should still be a key design aim
- Ventilation design strategy for HVAC:
 - Passive design approach, before mechanical systems are applied

Ventilation design hierarchy

Is it feasible to use
Natural Ventilation?

If situation prevents this,
is it feasible to use
Mechanical Ventilation?

If situation prevents this,
is it feasible to use
Hybrid/Mixed Mode Ventilation?

If situation prevents this,
is it feasible to use
**Cooling and Heating
(without humidity control)?**

If situation prevents this,
is it feasible to use
**Full Air Conditioning
(with humidity control)?**

Increasing:

- energy consumption
- capital cost
- running costs
- maintenance
- complexity

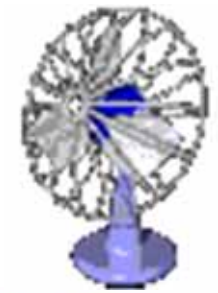

Ventilation Strategy

- Key factors affecting natural ventilation:
 - Depth of space related to ventilation openings
 - Ceiling height
 - Thermal mass exposed to the air
 - Location of building and possible air pollutants
 - Heat gain
 - Climate, e.g. outdoor temperature or wind velocity
- Can achieve passive cooling effect
 - Technologies or design features used to cool buildings without power consumption

Design strategies of natural ventilation

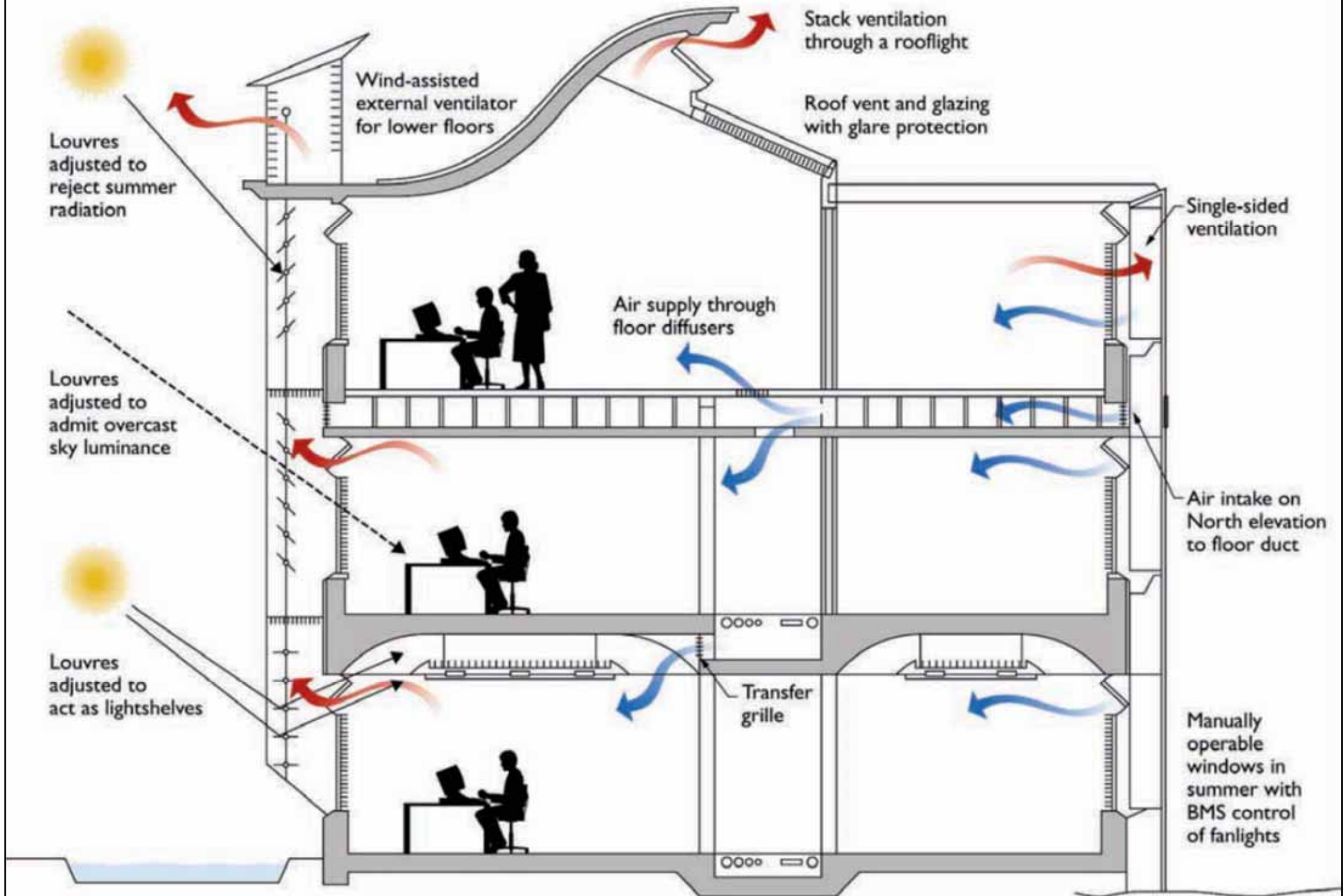

(Source: Pennycook, K., 2009. *The Illustrated Guide to Ventilation*)

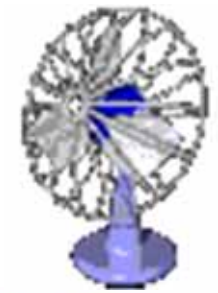

Ventilation Strategy

- Hybrid ventilation (mixed mode ventilation)
 - = Natural ventilation + Mechanical ventilation (and/or full air conditioning)
 - Use them at different time of the day or seasons of the year
 - Usually have a control system to switch between natural and mechanical modes
 - Combine the advantages of both to satisfy the actual ventilation needs and minimise energy consumption

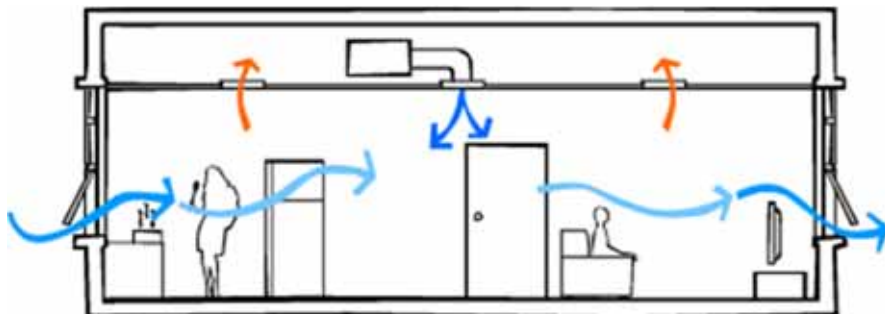

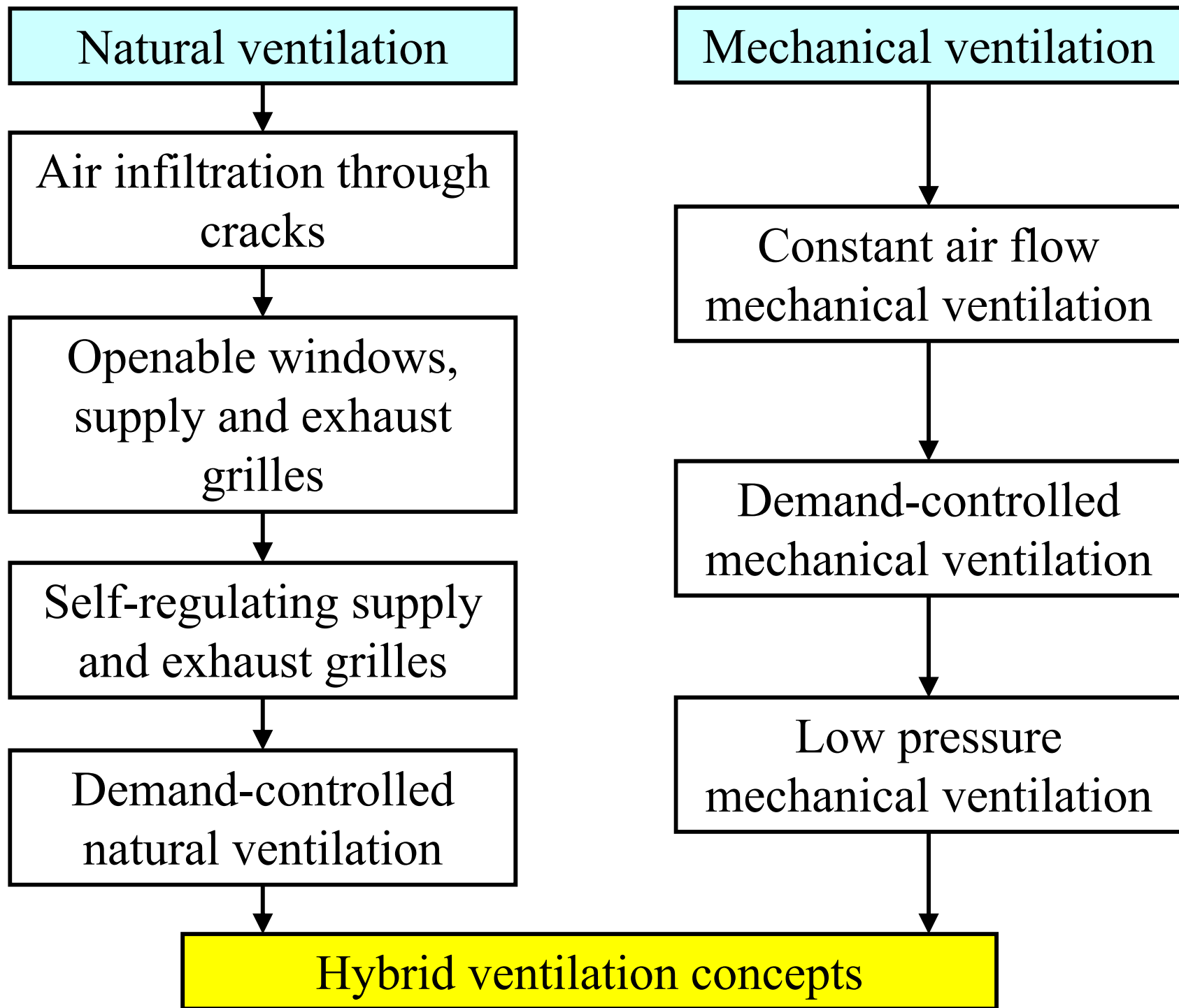

(See also: <http://www.build.com.au/mixed-mode-hybrid-ventilation>)

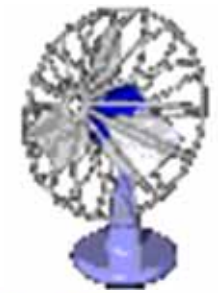

Ventilation Strategy

- Three types of mixed mode/hybrid ventilation:
 - Concurrent (Same space, same time)
 - Air-conditioning system and operable windows operate in the same space and at the same time
 - Change-over (Same space, different times)
 - “Changes-over” between natural ventilation and air-conditioning on a seasonal or even daily basis, such as by using the building automation system
 - Zoned (Different spaces, same time)
 - Different zones within the building have different conditioning strategies

Mixed Mode Natural Ventilation Flow and Control

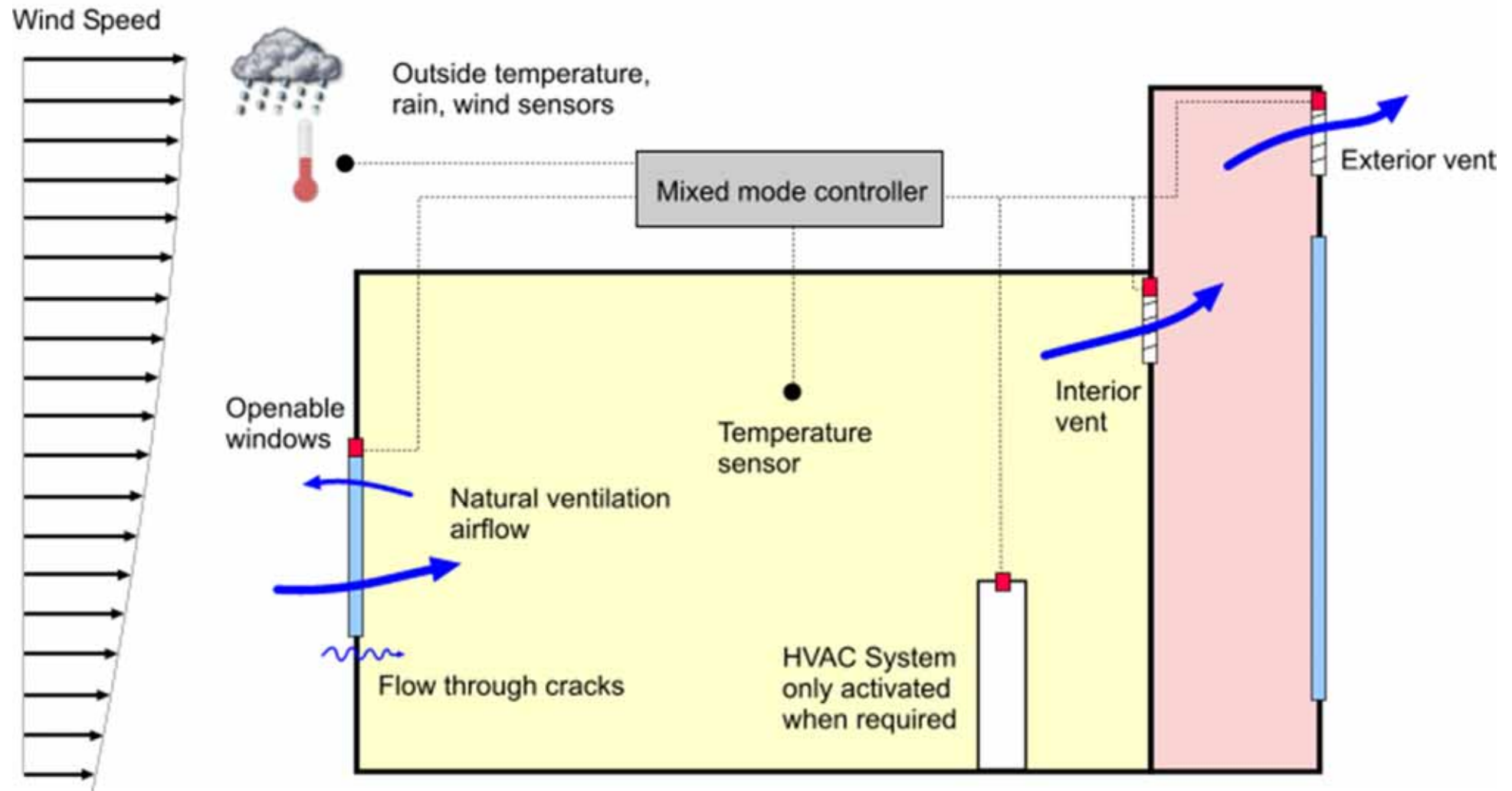

- * Multizone airflow model solved simultaneously with HVAC and building
- * Wind and Buoyancy pressure causes flow through openings and cracks
- * Windows and vents opened when $T_{air} > T_{setpoint}$, closed when HVAC operates
- * Priority given to natural ventilation - HVAC operates only when required
- * Windows and vents are shut off when external conditions are extreme (wind, rain, cold, hot etc).

Intelligent control of mixed mode/hybrid ventilation system (with remote interfaces, external and internal sensors)

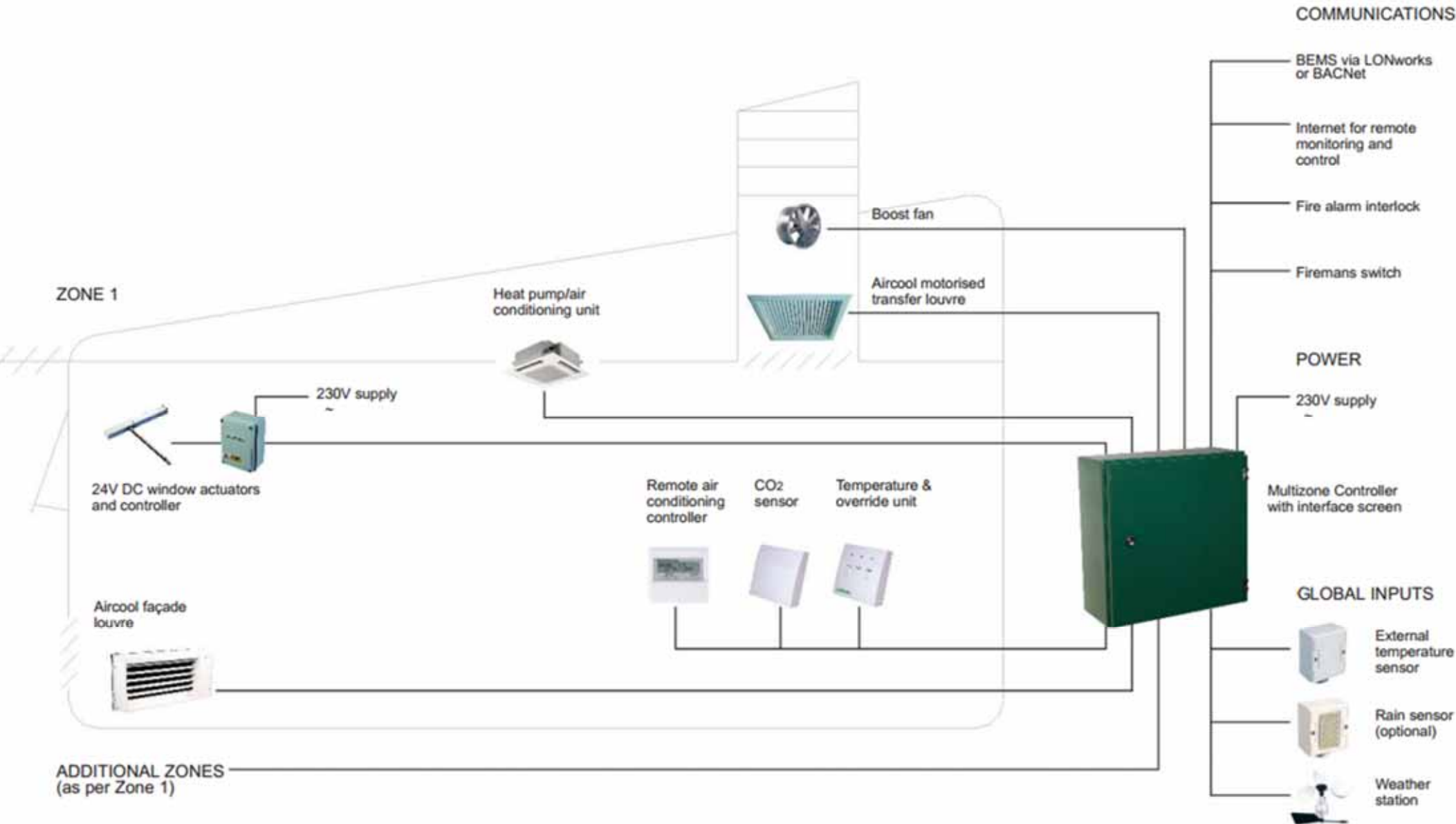

(Source: <http://www.passivent.com/>)

Ventilation Strategy

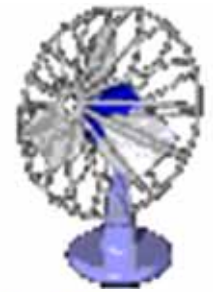

- Design assessment techniques

1. Full scale mock-up

- For a representative section of the building
- It is placed in a large environmental chamber that can simulate external conditions (e.g. solar, wind)
- Evaluate HVAC system and the control system

- 2. Analogue modelling

- Air movement in convective flow (natural ventilation) may be modelled in a water tank, using salt solutions
- For a scale model of a section of the building



Ventilation Strategy

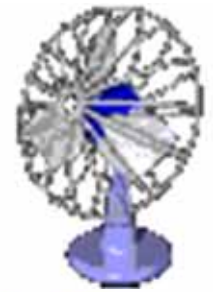

- Design assessment techniques (cont'd)

- 3. Mathematical modelling

- Building thermal simulation and computational fluid dynamics (CFD)
 - Modelling of energy use and air movement

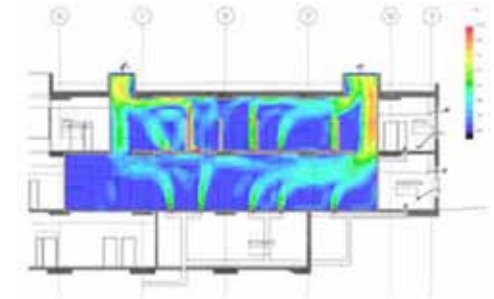

- 4. Emulation

- An emulator consists of a simulation of a building and its HVAC system is connected to a real BMS
 - Can be used for evaluating BMS performance, training BMS operators, assisting in the development of new control algorithms, fine tuning the control parameters

Displacement Ventilation



- Displacement flow

- Cold supply air at a velocity nearly equal to the required velocity and displace the original air with piston-like airflow w/o mixing
- If properly designed, it can give:
 - Better IAQ in occupied zone
 - Higher space diffusion effectiveness
 - Low turbulence intensities & fewer draft problems
- Drawbacks:
 - Require greater supply volume flow rate
 - Higher construction cost

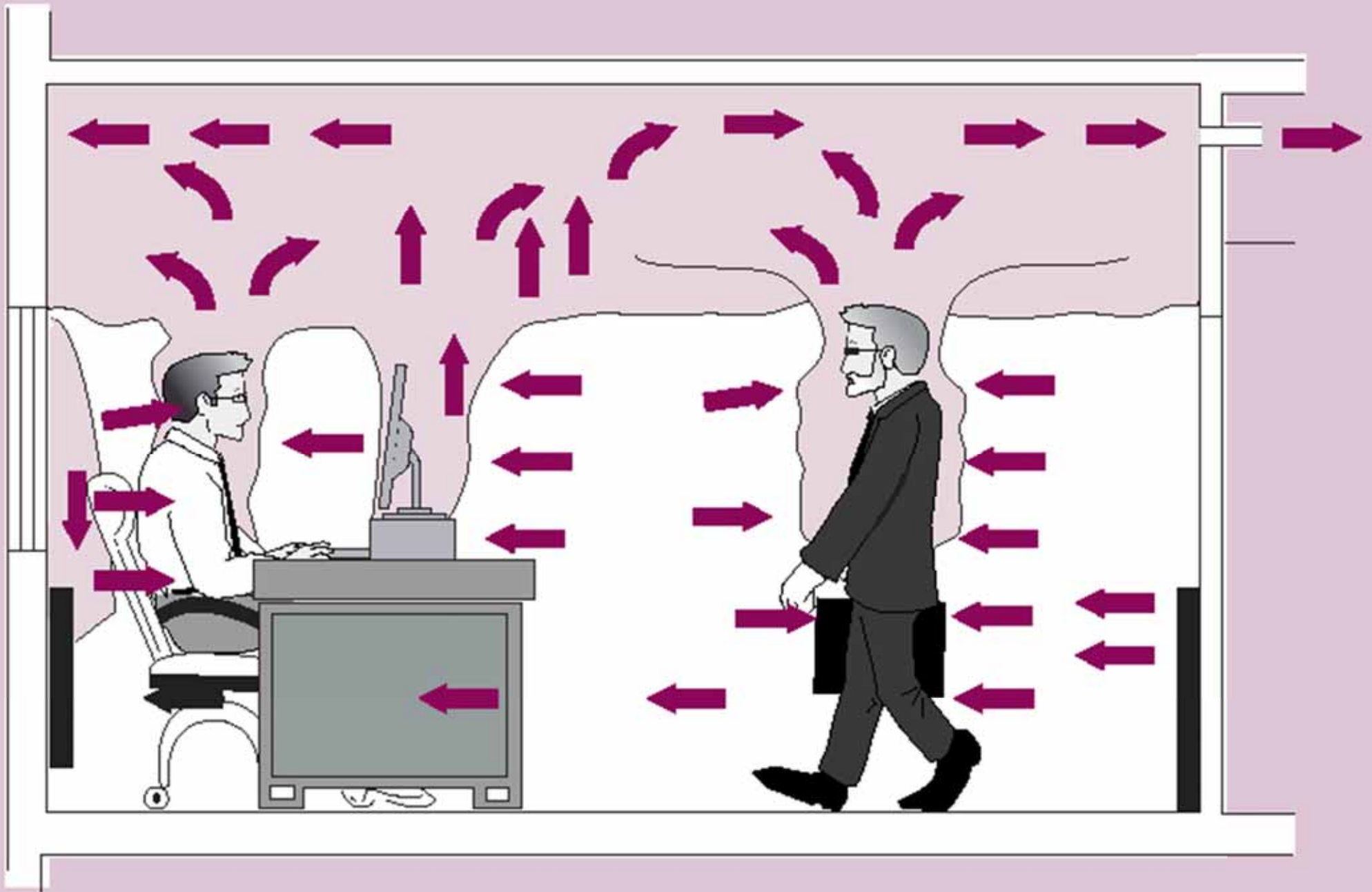

Displacement flow characteristics

(Source: <http://www.price-hvac.com>)



Displacement ventilation (DV)



Mixing ventilation (MV)

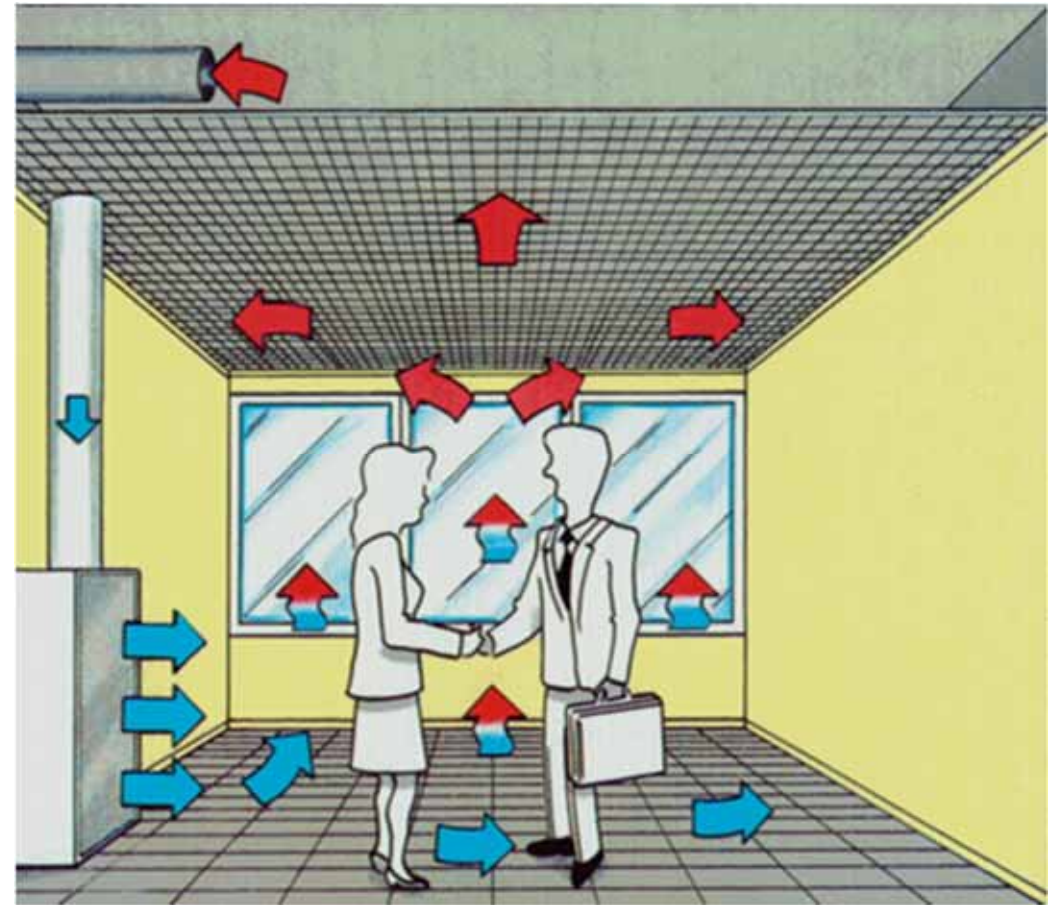
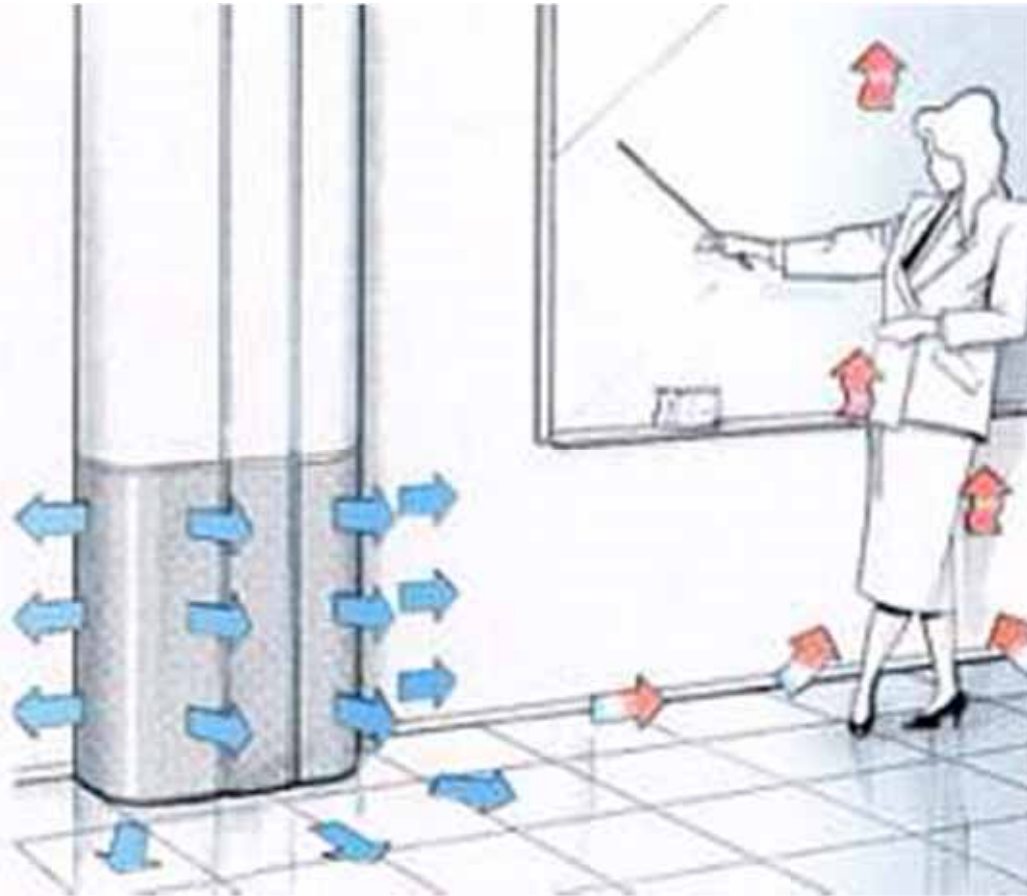

Displacement ventilation system

Displacement Ventilation



- Airflow patterns
 - Because of low discharge velocity, air motion is influenced to a large degree by convection flows
 - Convection flows (or thermal plumes) are created by heat sources, e.g. people, equipment, warm windows
 - Cold sinks (e.g. cold windows) may create flows down
- Airflow penetration
 - Supply air spread across the floor in a thin layer, filling the entire space
 - Flow around & beyond obstructions

Figure 5 - Horizontal Air Movement

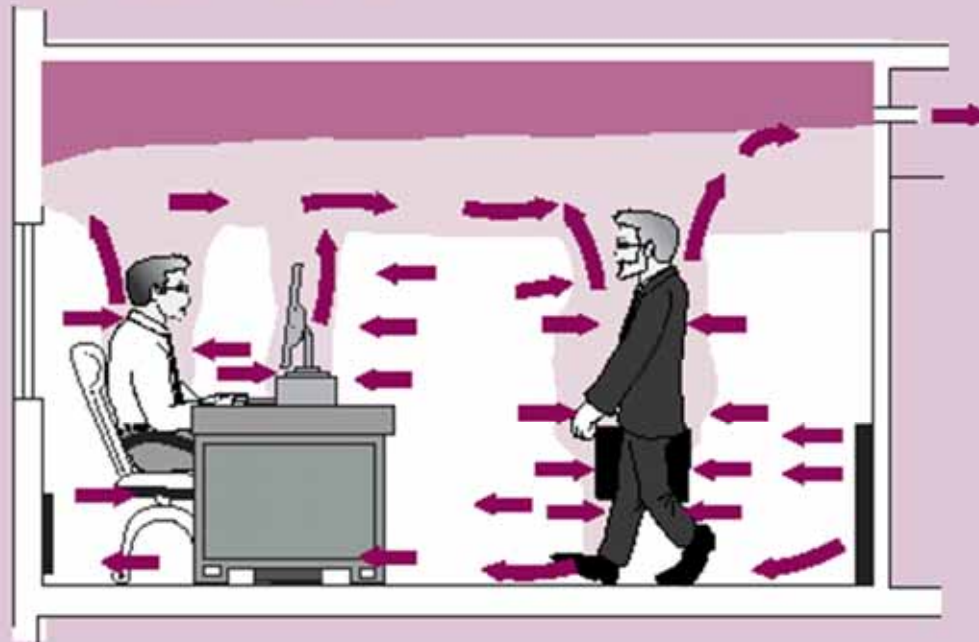
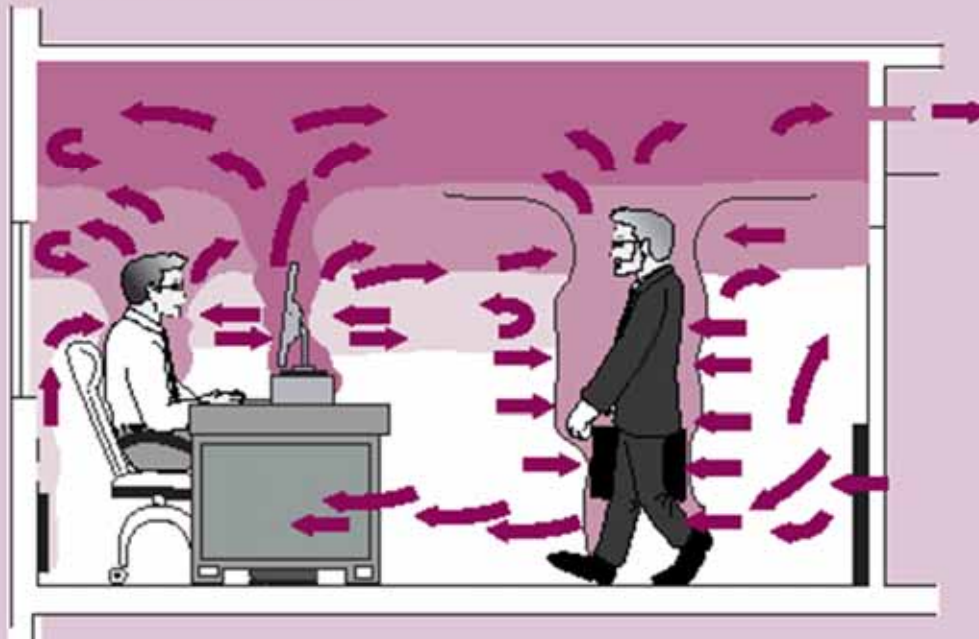

Figure 6 - Vertical Air Movement



Displacement flow patterns

(Source: <http://www.price-hvac.com>)

Figure 12 - Contaminant Distribution

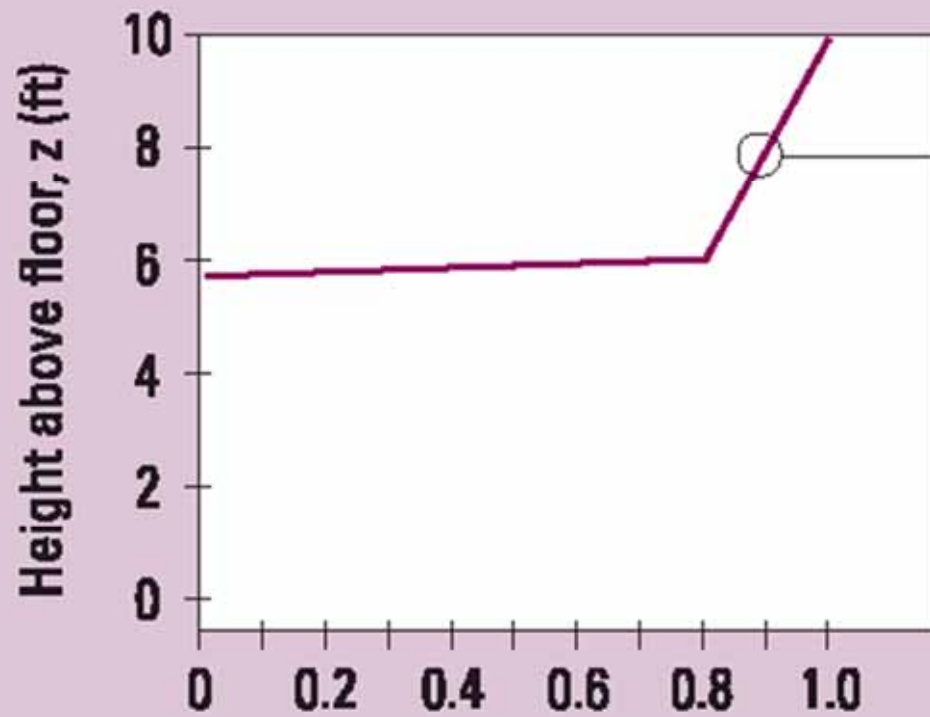

Contamination ratio, $C_{room} / C_{exhaust}$

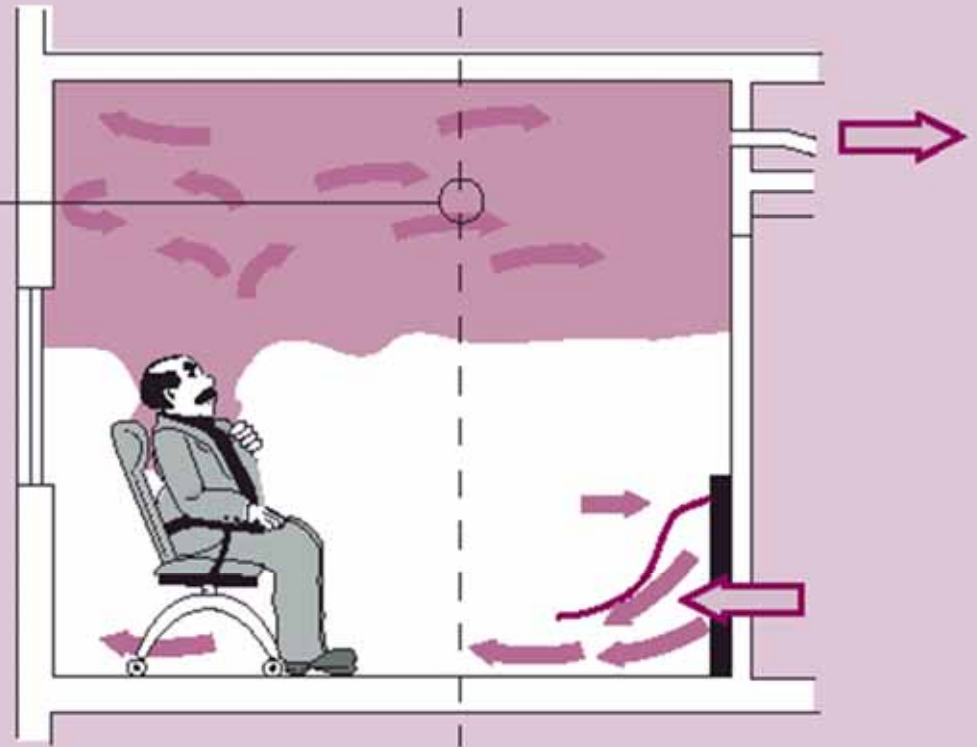

Ref: REHVA Guidebook

Displacement Ventilation



- Temperature distribution
 - Temperature gradient between the floor & ceiling
 - Also known as “Stratification”
 - Affected by factors e.g. supply air volume, room cooling load, location & type of heat source, height of the space
 - Controlling stratification is critical to maintain thermal comfort
- If heating is needed, may use radiator to offset cold downdrafts near the windows

Figure 13 - Vertical Temperature Gradient

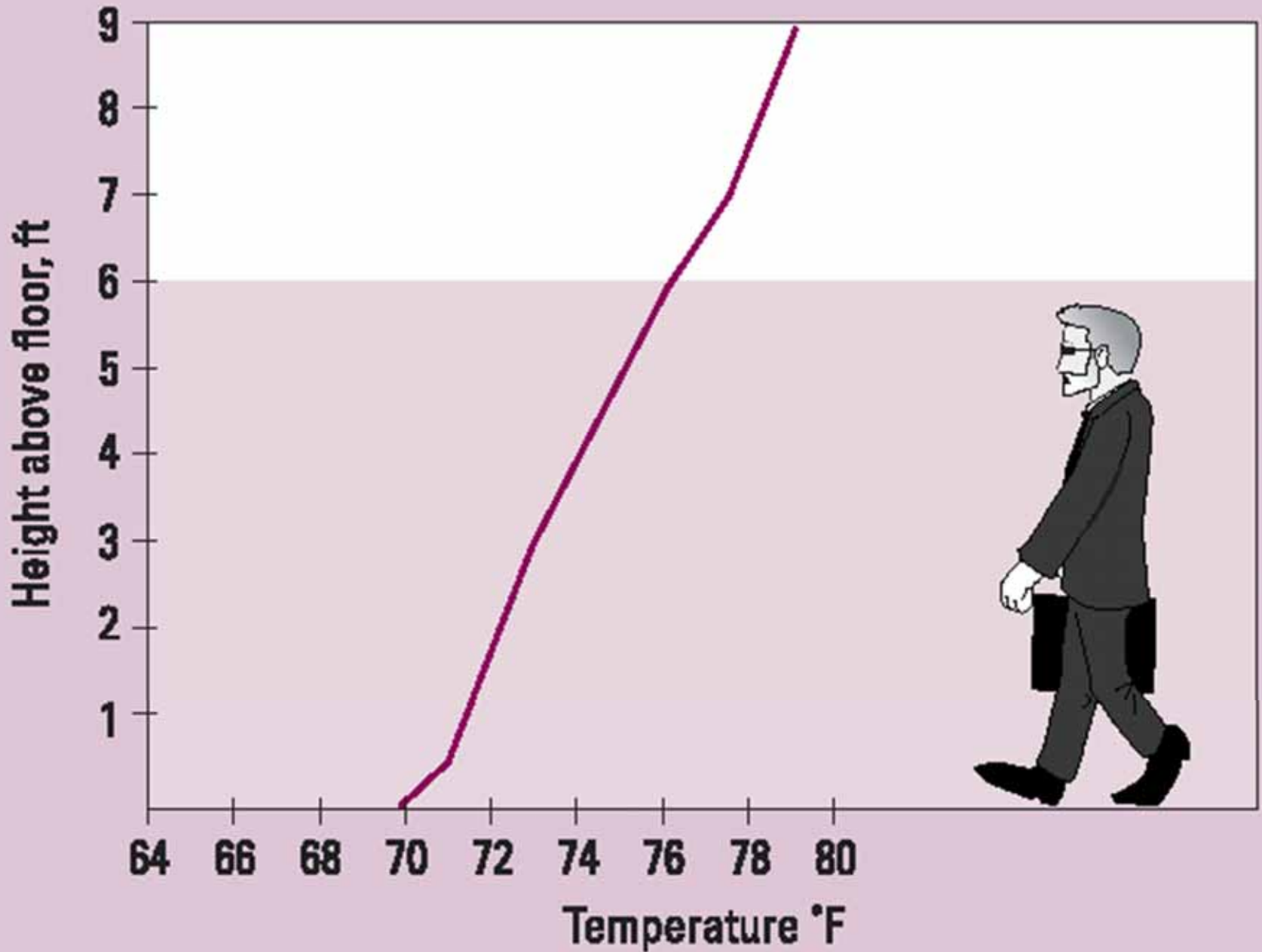

Displacement ventilation – temperature gradient

(Source: <http://www.price-hvac.com>)

Figure 14 - Heat Source Location

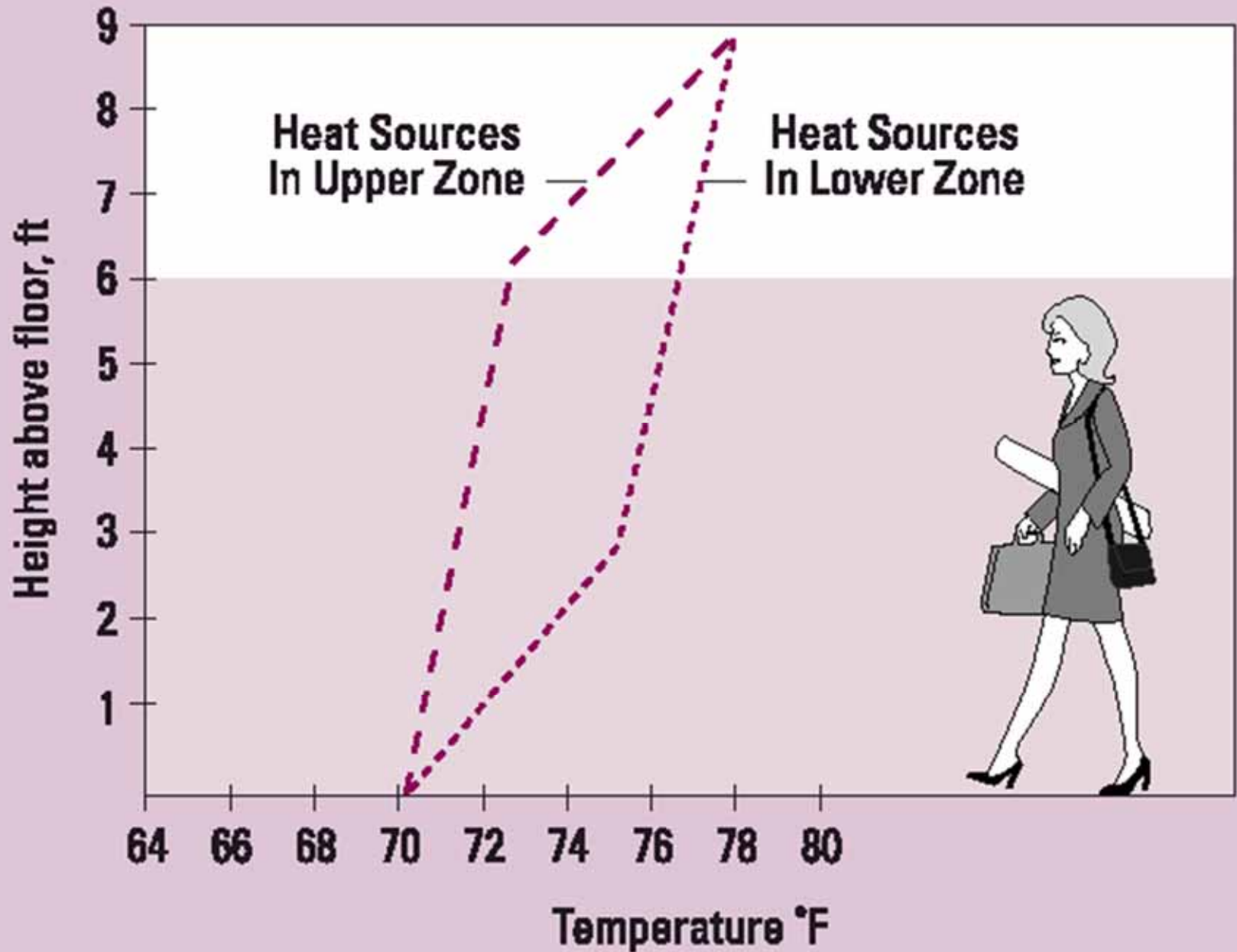

Displacement ventilation – temperature gradient

(Source: <http://www.price-hvac.com>)

Displacement Ventilation



- Stratified displacement flow
 - First introduced in Scandinavian countries
 - Low-level supply outlet
 - Above heat & contaminated sources
 - Heated air rises upward due to buoyancy effect
 - Supply air is entrained into the upward convective flow
 - Stationary level: upward flow = supply flow
 - Two-zone stratified model: upper zone & lower zone

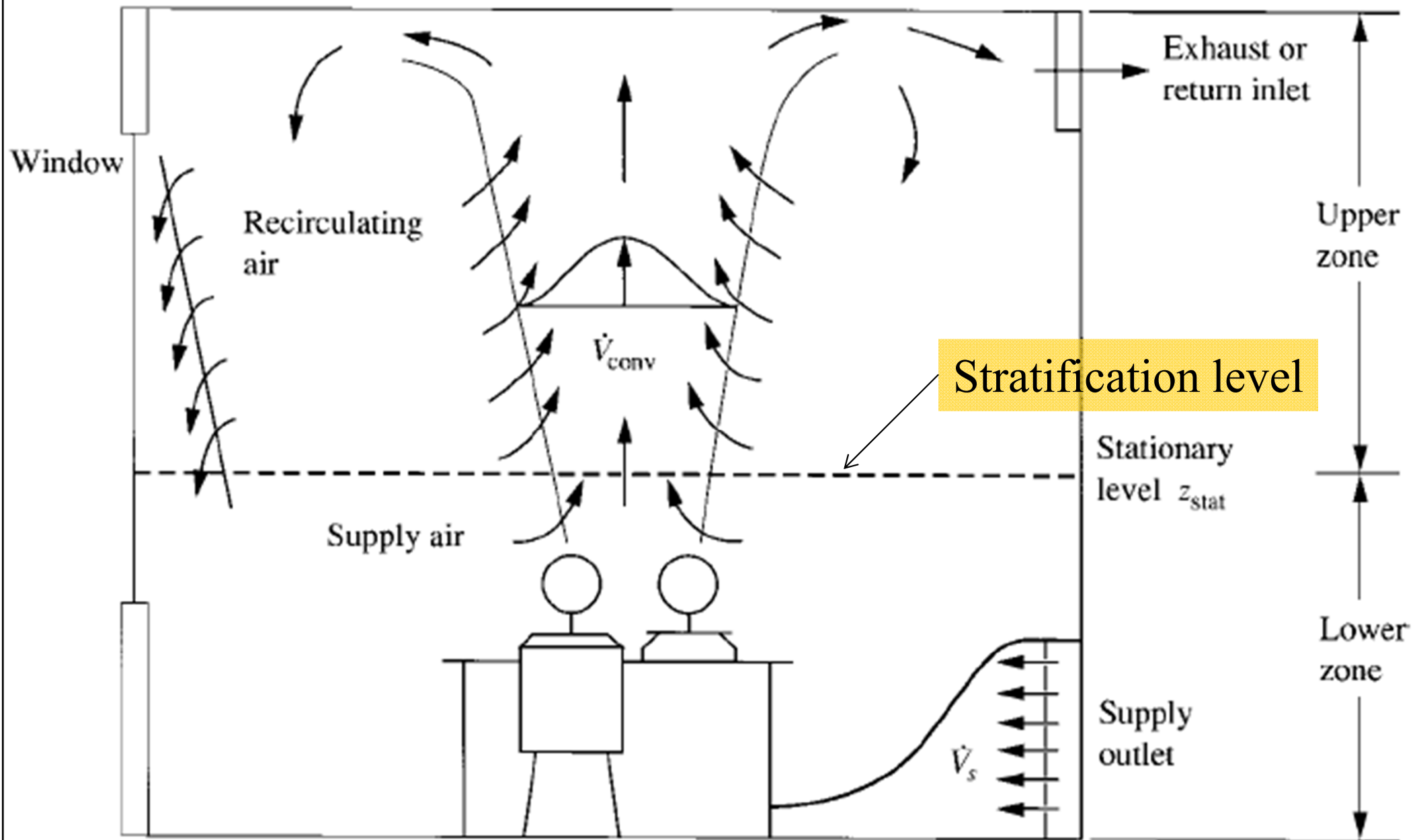

Stratified displacement flow in a typical room

Displacement ventilation design

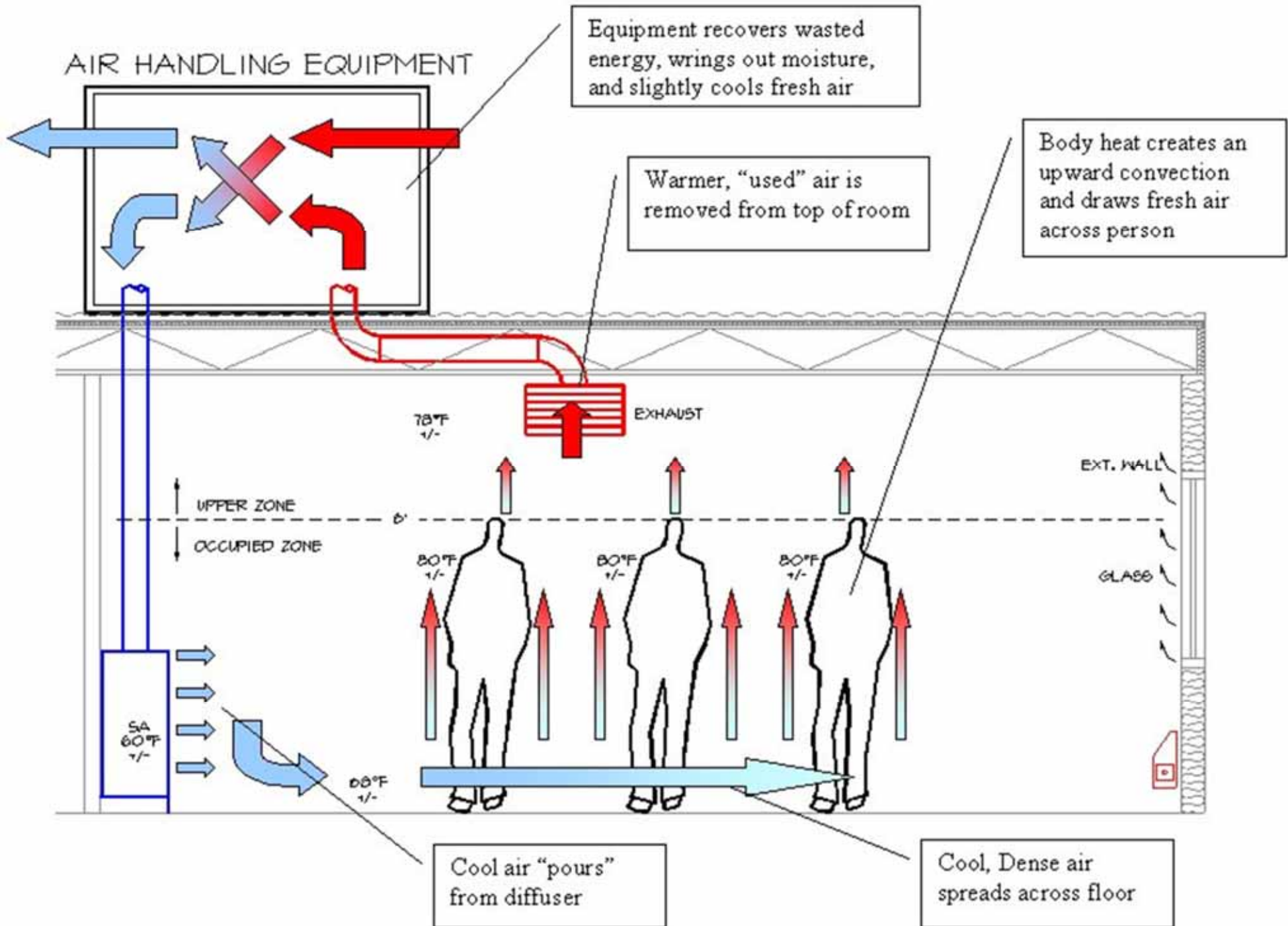

Displacement Ventilation



- Characteristics of stratified displacement flow
 - Cold air supply of usually 100% outdoor air
 - Air must be supplied at low velocity (< 0.3 m/s) & at a height less than 0.54 m above floor
 - Cold air supplied at 2.8 to 5 °C lower than occupied zone
 - Height of lower zone shall be higher than a seated occupant (1.4 m); all air is supply air in lower zone
 - Smaller cooling load density (max. 41 W/m²)
 - Return or exhaust inlets located near ceiling level

Example of analysis on displacement ventilation

Question: Consider a room 3 m high. What is the likely sensible heat extraction by displacement ventilation? How does this compare with conventional mixed flow air conditioning?

Solution: Assuming the max. temperature gradient of 3 K m^{-1} throughout the room height, then for a room of 3 m this produces a temperature difference of 9 K between supply and extract (assuming extract is at the top of the room). Assume the maximum air change rate is 3 air change per hour, the air supply for 1 m^2 of floor area is $9 \text{ m}^3 \text{ h}^{-1}$ (or 2.5 L s^{-1}). This gives a sensible cooling capacity of:

$$V\rho C_p \Delta t$$

where $V =$ volume flow rate ($\text{m}^3 \text{ s}^{-1}$)

$\rho =$ density of air (1.2 kg m^{-3})

$C_p =$ specific heat capacity of the air ($1.02 \text{ kJ kg}^{-1} \text{ K}^{-1}$)

$\Delta t =$ supply to extract air temperature difference (K)

So the cooling capacity is: $(2.5 / 1000) \times 1.2 \times 1020 \times 9 = \underline{\underline{27.5 \text{ W m}^{-2}}}$

For mixed-flow air conditioning there can be up to 15 air changes per hour and the air supply rate for 1 m^2 of floor area is $45 \text{ m}^3 \text{ h}^{-1}$ (or 12.5 L s^{-1}). With a typical temperature difference of 8 K between the supply air and extract air, this gives a sensible cooling capacity of: $(12.5 / 1000) \times 1.2 \times 1020 \times 8 = \underline{\underline{122.4 \text{ W m}^{-2}}}$

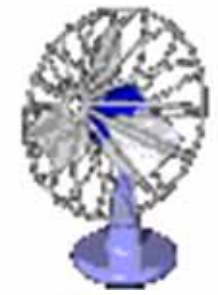

Chilled Ceiling

- Chilled ceiling and chilled beam (CC+CB)
 - Used in Europe since mid-80s; Become popular in other countries
 - Potential benefits
 - Better thermal comfort
 - Lower energy consumption
 - Smaller air flow rate
 - Low sound level
 - Green building credits

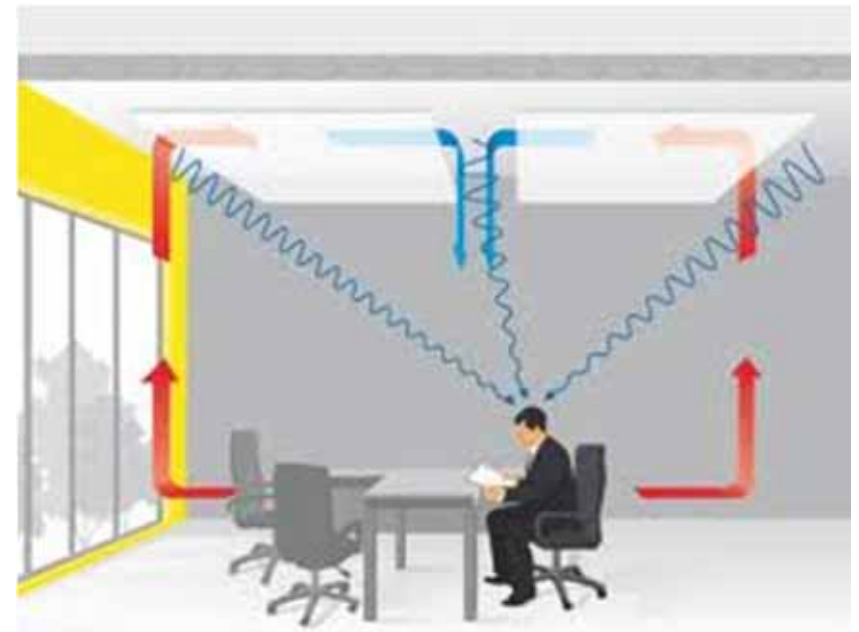

(*See also: <http://archtoolbox.com/materials-systems/hvac/120-chilled-beam-ceiling.html>)

Example of an installation with chilled beams, chilled ceiling panels and displacement ventilation

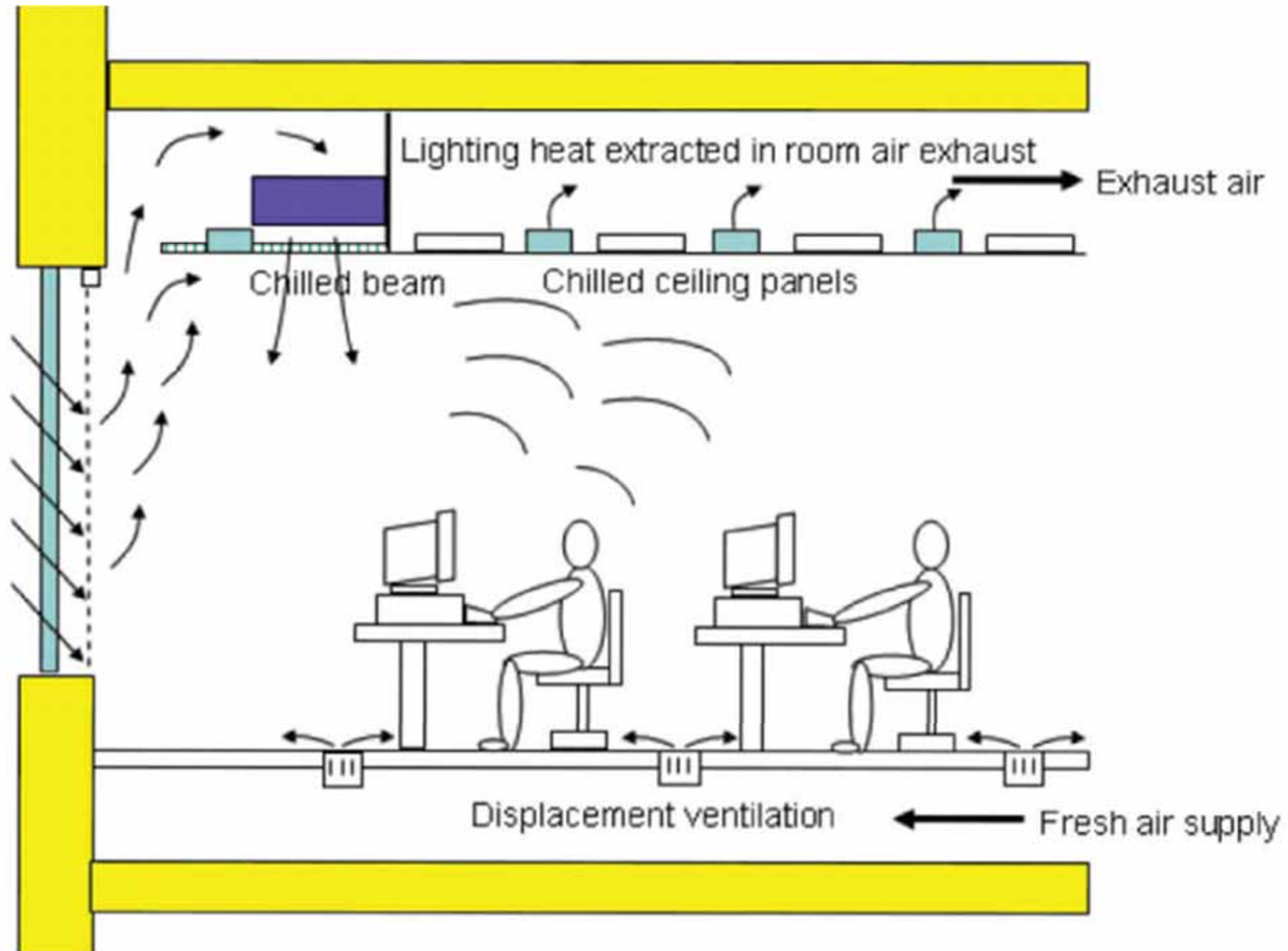

Examples of chilled ceiling panels

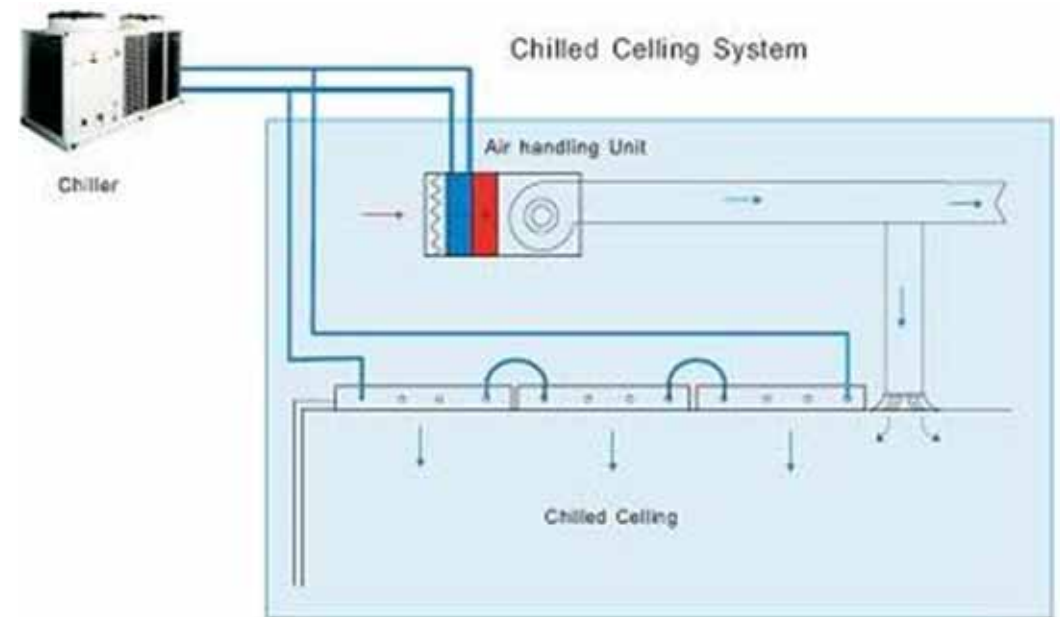

(Source of images: www.kuehldecken.de and www.sasint.co.uk and www.barcolair.cn)

Operating principle of chilled ceiling systems

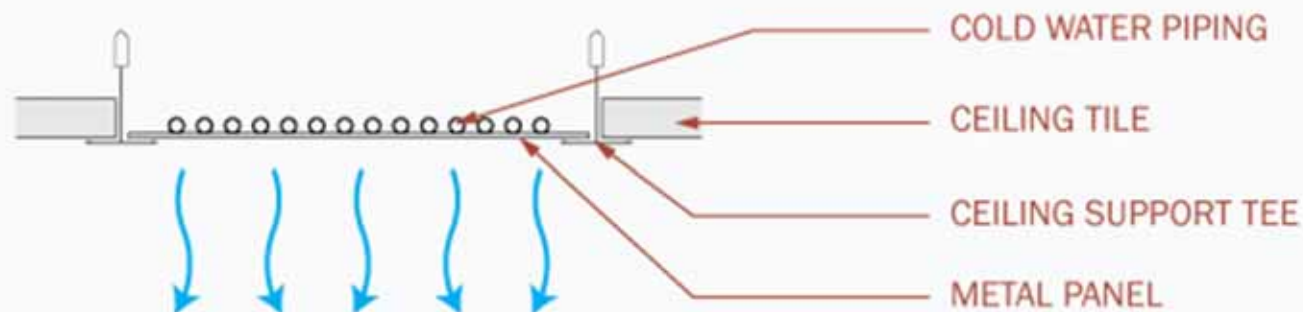
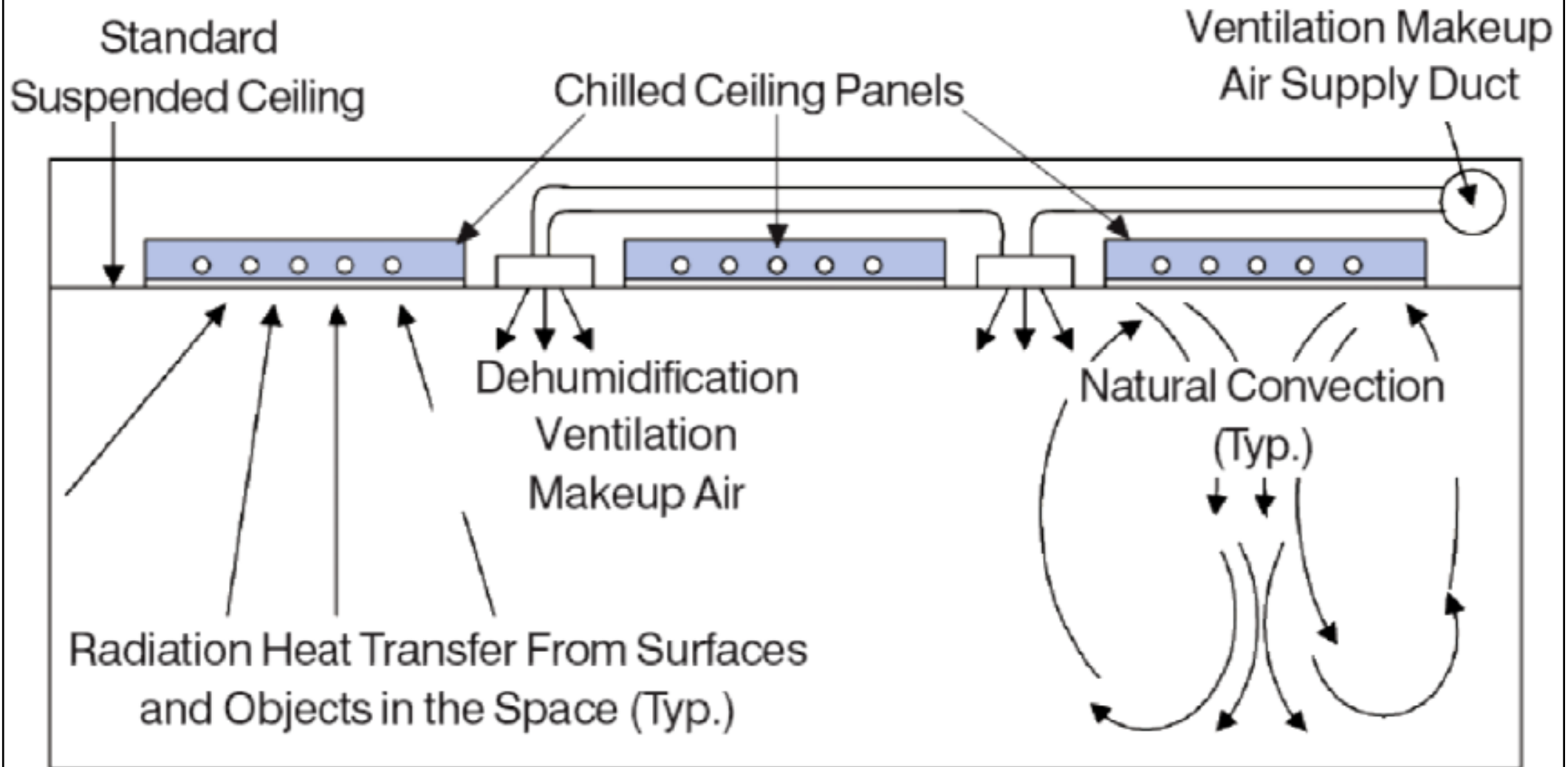

Types of chilled beam systems

Passive chilled beams

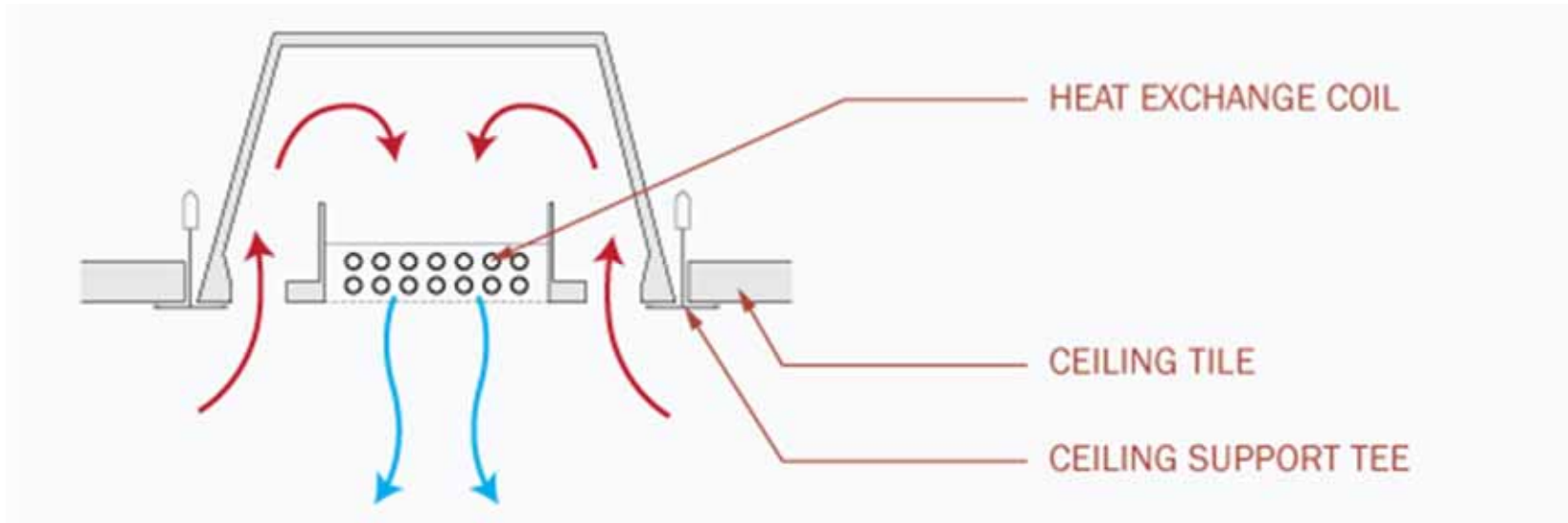

Active chilled beams

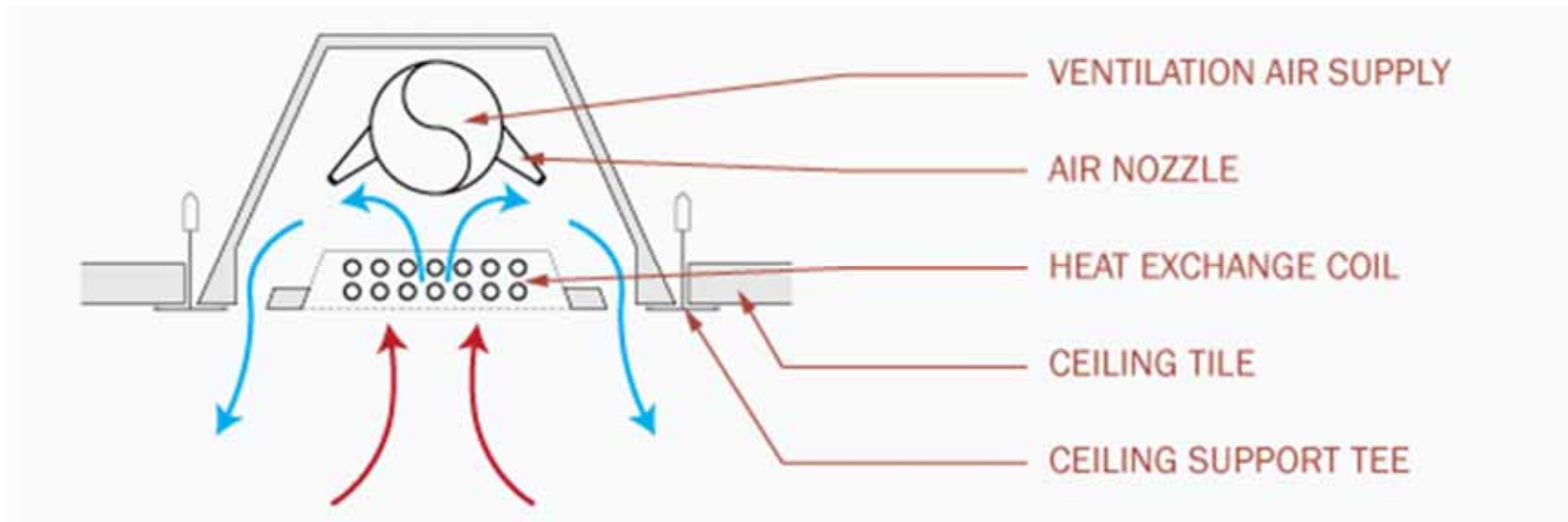

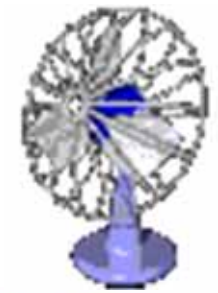

Chilled Ceiling

- **Chilled ceiling system:** Water-based cooling
 - Ceiling-based radiant cooling panels coupled with chilled water pipes or coils (14-17 °C)
 - A combination of natural convection & radiation
 - A separate dedicated outdoor air system (DOAS) is used to dehumidify the outdoor air
- **Thermal comfort**
 - Supply air flow rate is lower => draft is reduced
 - Small temperature difference between room air and chilled ceiling surface

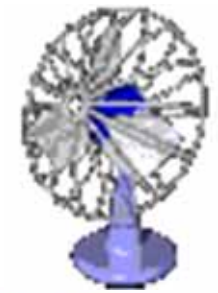

Chilled Ceiling

- **Chilled ceiling:** Thermal comfort (cont'd)
 - Higher indoor temperature can be used => decrease cooling loads and energy use
- Energy performance
 - Higher chilled water temp
 - => Higher chiller evaporative temp
 - => Chiller energy saving
 - Supply air flow rate is lower
 - => Fan energy saving
 - Radiation w/ mixed convection heat transfer

Example of analysis on chilled ceiling (1)

Question: Consider a chilled ceiling with a mean water temperature of 17 °C and a room air temperature of 27 °C. Assume a mean radiant temperature of 25 °C. Does theory confirm the output given?

Solution: Please refer to pages 400-402 of the reference book ([Example 12.3](#)).*

Numerical answers:

The total cooling output of the ceiling panels = 84 W m⁻²

The dry resultant comfort temperature = 26 °C

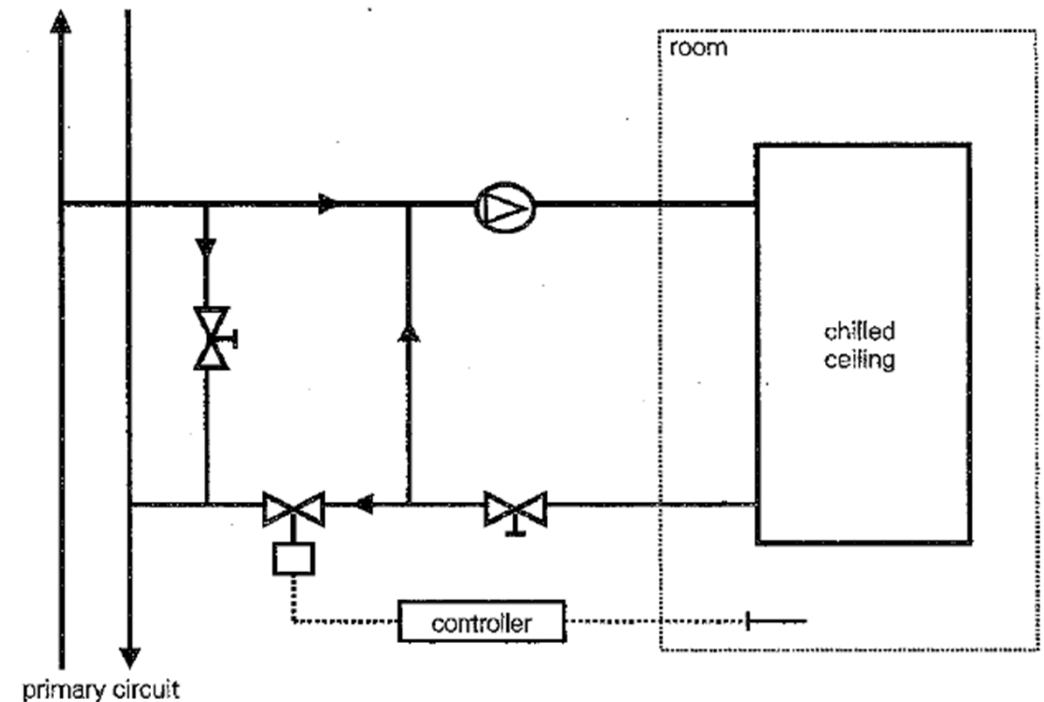
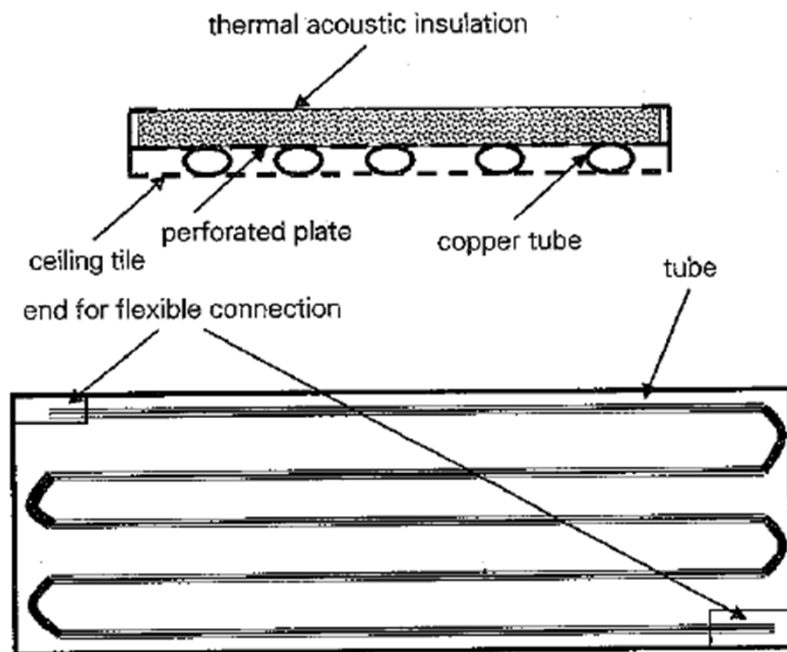

[*Levermore, G. J., 2000. *Building Energy Management Systems: Application to Low-energy HVAC and Natural Ventilation Control*, 2nd ed., E & FN Spon, London & New York]

Example of analysis on chilled ceiling (2)

Question: A chilled ceiling system has been installed with a polypropylene pipework lattice behind the ceiling tiles. The output of the tiles is given by: $q = C(t_{mw} - t_{ai})^n$. For this system, $C = 5.56$, $n = 1.105$; t_{mw} is the mean water temperature in the pipes and q is the heat absorbed by the panel (W m^{-2}). The flow water temperature is designed to be $14\text{ }^\circ\text{C}$ and the return $17\text{ }^\circ\text{C}$ with a maximum air temperature at high level of $25.5\text{ }^\circ\text{C}$. If the flow water temperature is controlled at $14\text{ }^\circ\text{C}$ but the heat gain falls to half the design value, what does the room air temperature become if there is no control on the panel? Assume the heat gain is equally radiant and convective.

Solution: Please refer to pages 404-405 of the reference book ([Example 12.4](#)).*

Numerical answer:

The room air temperature = $20.09\text{ }^\circ\text{C}$

[*Levermore, G. J., 2000. *Building Energy Management Systems: Application to Low-energy HVAC and Natural Ventilation Control*, 2nd ed., E & FN Spon, London & New York]

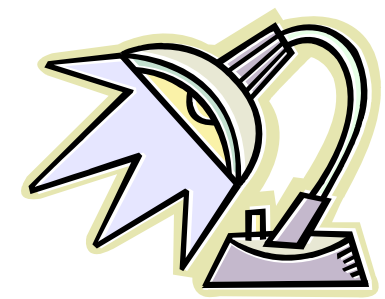

Lighting Control

- Three main functions of lighting:
 - Ensure the safety of people
 - Facilitate the performance of visual tasks
 - Aid the creation of an appropriate visual environment



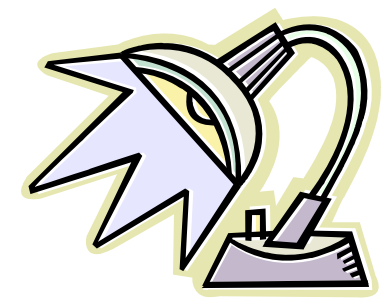

Lighting Control

- Basic principle of lighting control system

Perceive using sensors

Reason using a controller

Act using actuators

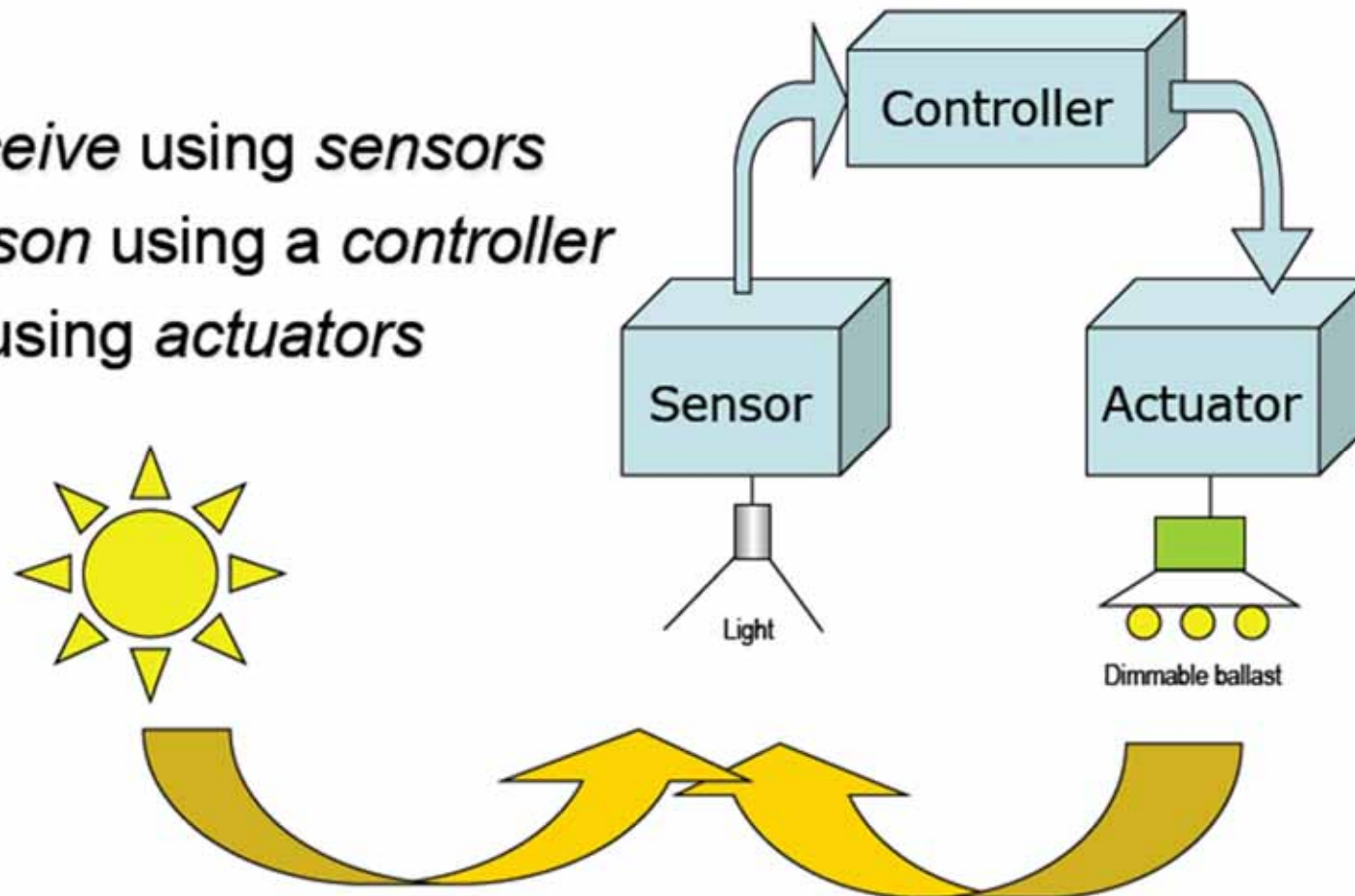

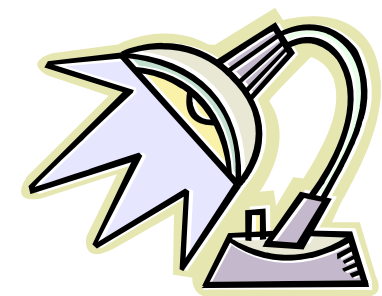

Lighting Control

- Lighting control equipment:
 - Switches
 - Occupancy sensing
 - Scheduling (timeclocks)
 - Daylight dimming
 - Tuning
 - Preset dimming
 - Wireless controls

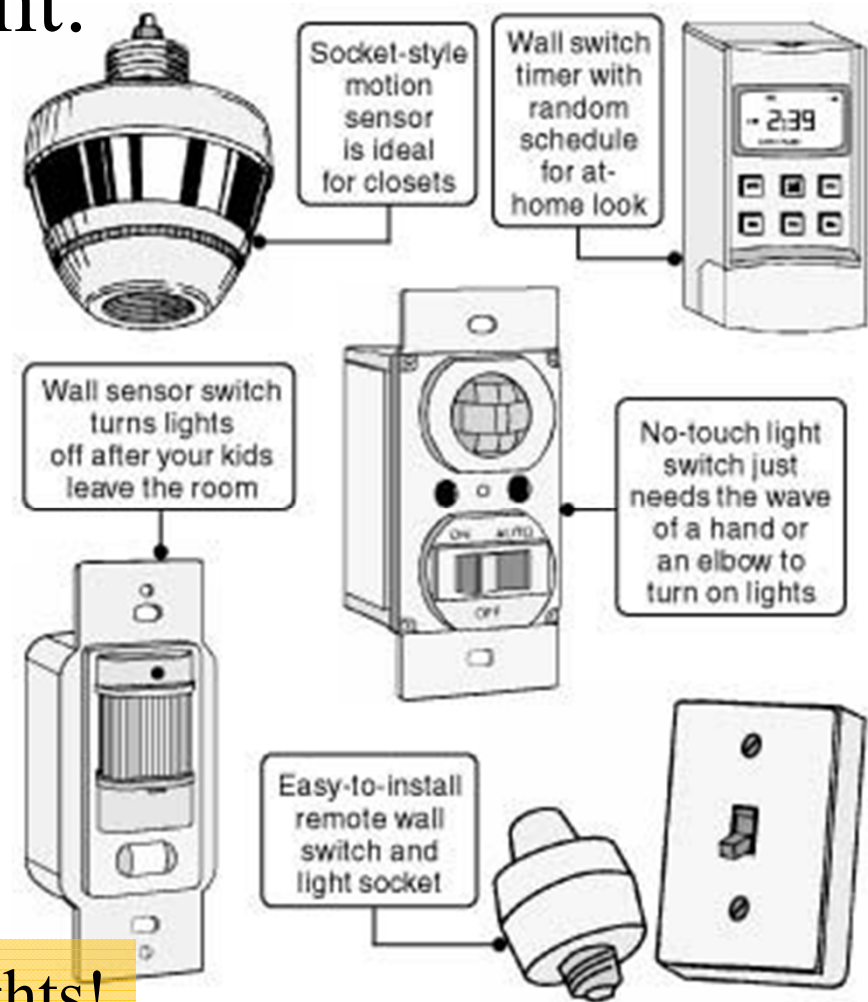

Remember: switch off unnecessary lights!

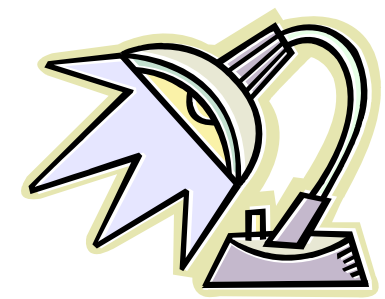

Lighting Control

- Lighting controls and communications

- Wired bus

- Analogue (0-10 V DC)

- Digital (DALI, digital addressable lighting interface)

- Control over powerline

- Two-wire phase control

- Powerline communications

- Radio communications

- WiFi, ZigBee, EnOcean

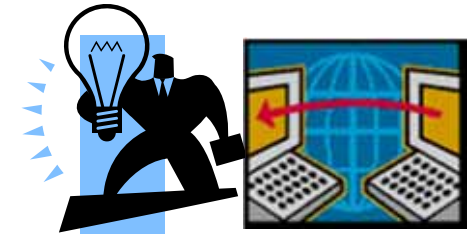

- Lighting ballast industry has selected DALI as its standardized wired digital protocol
- No generally accepted powerline communications scheme
- ZigBee is leading contender for future wireless lighting and building control products

Lighting Control 1990s: Analogue (0-10 V DC bus)

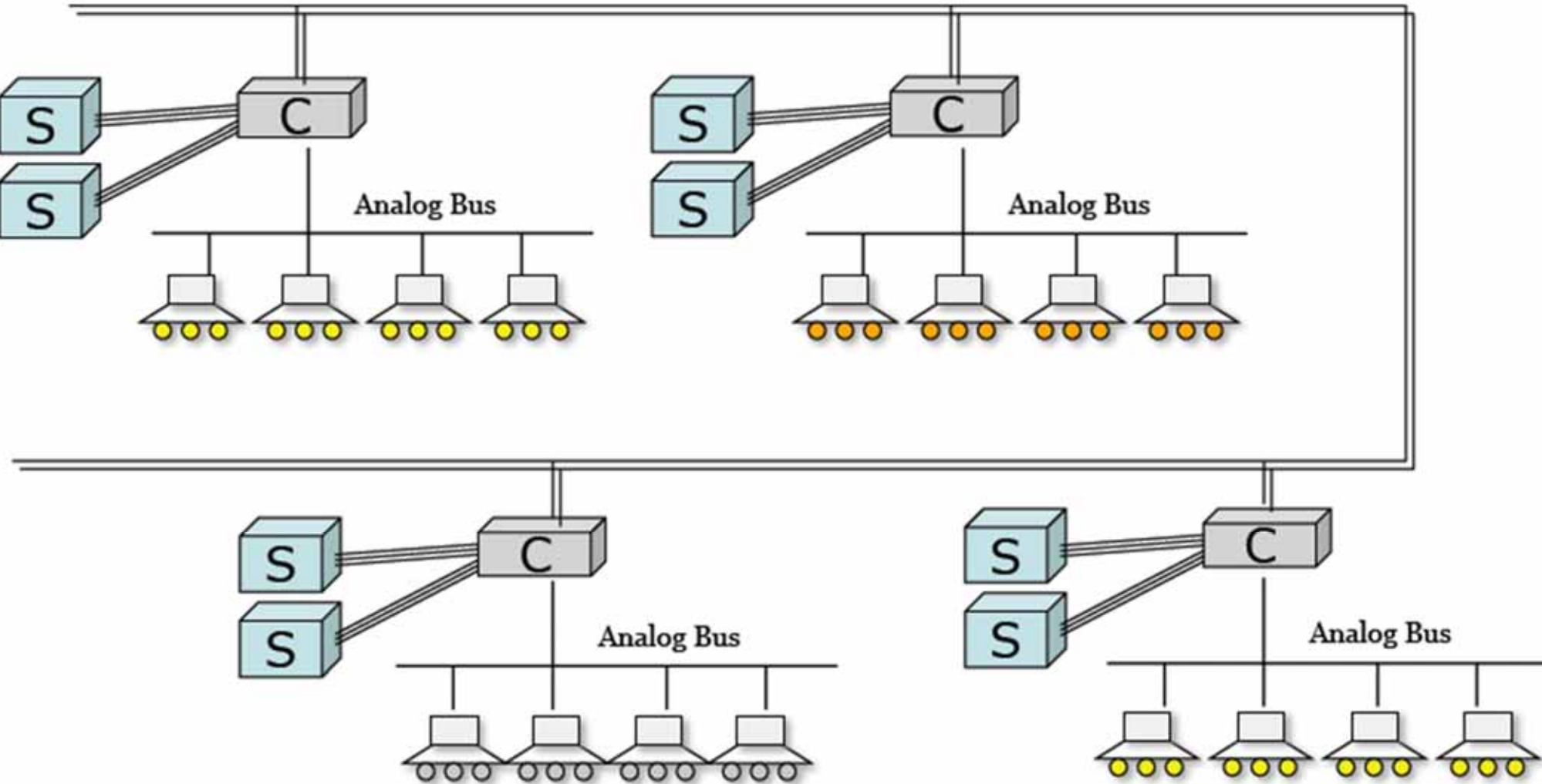

[Image Source: Prof. Konstantinos Papamichael, University of California, Davis]

Digital Lighting Control 2000s: Basic DALI

(DALI = digital addressable lighting interface)

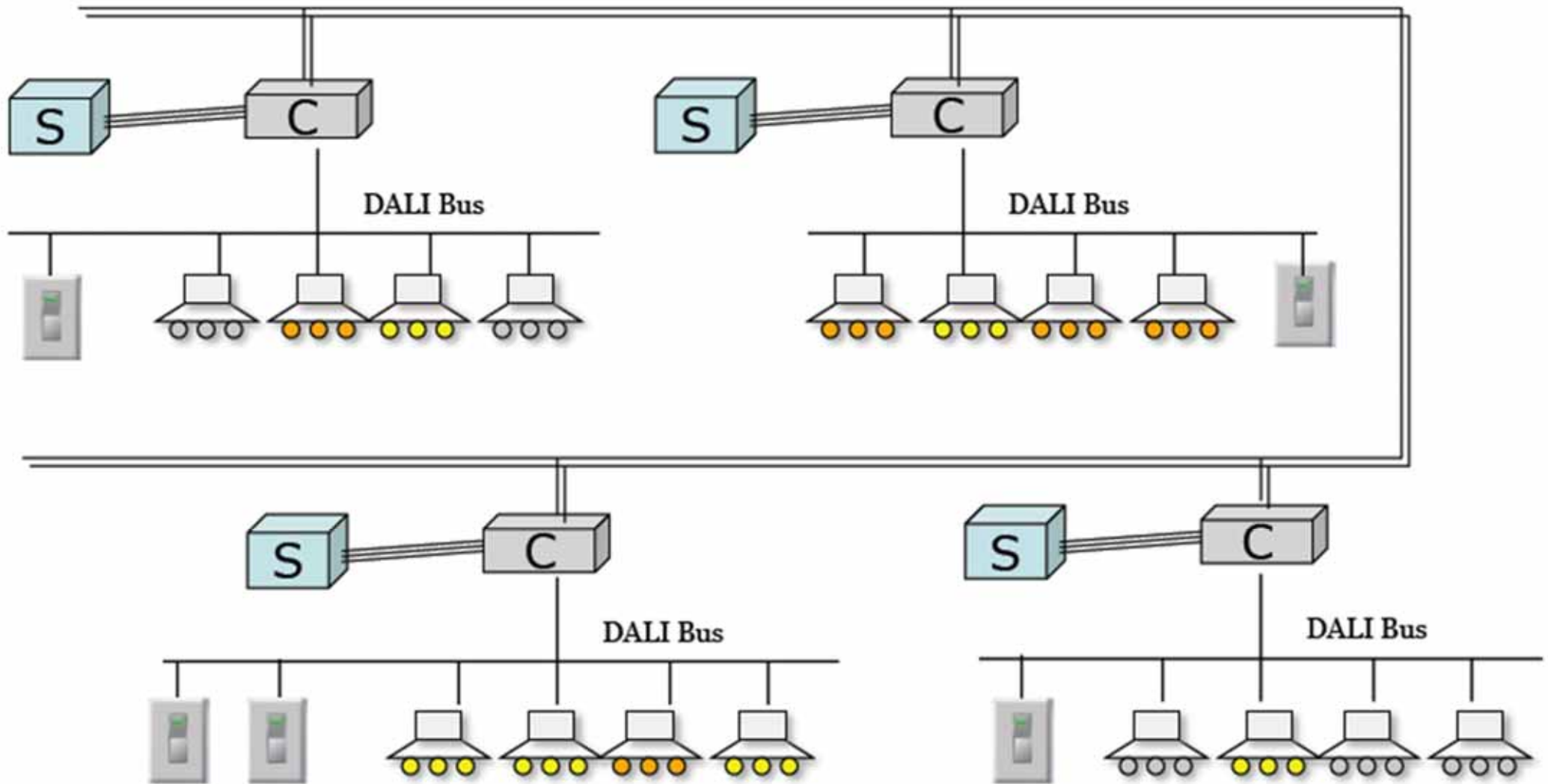

Full Peer-to-Peer Wireless (future)

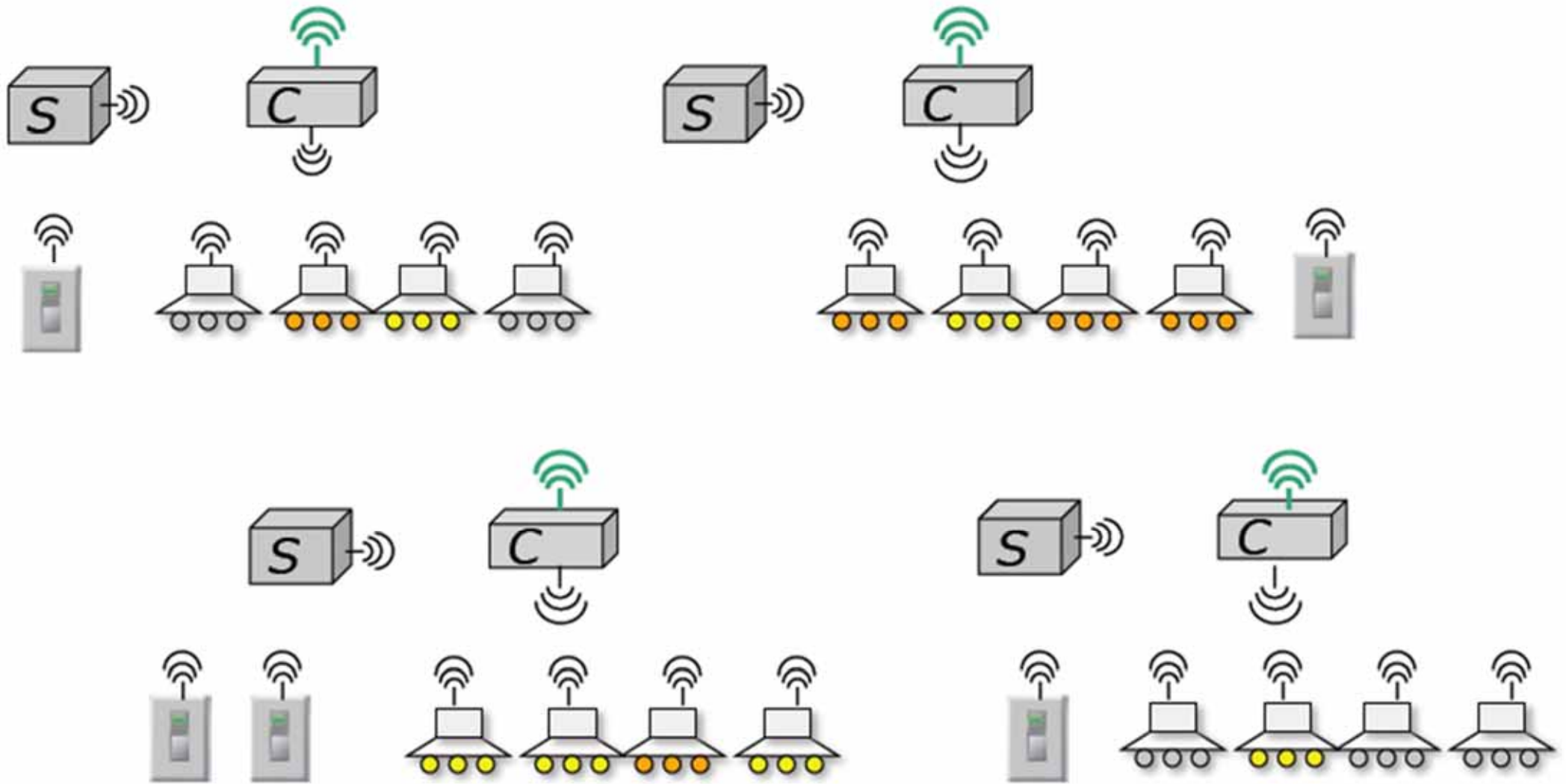

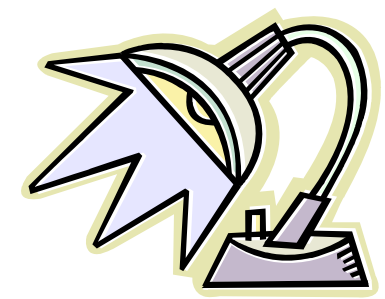

Lighting Control

- Controllable lighting strategies: Two issues
 - Energy efficiency
 - Vacancy detection, daylight harvesting, tuning, personal controls, adaptation compensation, lumen maintenance
 - Demand response (DR)
 - Changes in energy usage by end-use customers from their normal consumption patterns in response to the change in energy price over time or incentive payments
 - Slow or real time



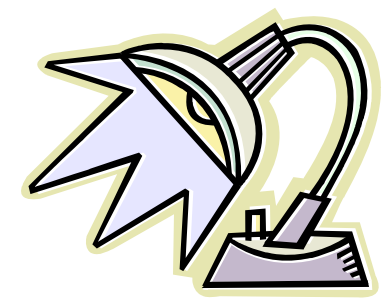

Lighting Control

- New and emerging technologies
 - Smart (intelligent) luminaires
 - Multiple light sources (to support different functions), embedded sensors, controller & communications
 - Automatic, continuous calibration
 - Multi sensor input
 - Occupancy sensing integration
 - Video-based occupancy & photo controls (for both occupancy and light sensing)
 - Advanced controls algorithms (e.g. predictive)

Intelligent luminaires have the potential to integrate various sensors



[Image Source: <http://www.ledsmagazine.com>]

Example of analysis on intelligent luminaire

Question: A intelligent luminaire can produce an illuminance of 800 lux on a person's desk. The desk has a reflectivity of 20%. The setpoint illuminance for the luminaire is 500 lux. The luminaire is providing a steady 300 lux on the desk when the window blind is down. The blind is then opened and daylight contributes a further 200 lux. How long does the luminaire take to adjust to this new condition with the above control schedule?

Solution: Please refer to pages 418-419 of the reference book ([Example 12.5](#)).*

Numerical answer:

The luminaire will take 28.1 seconds

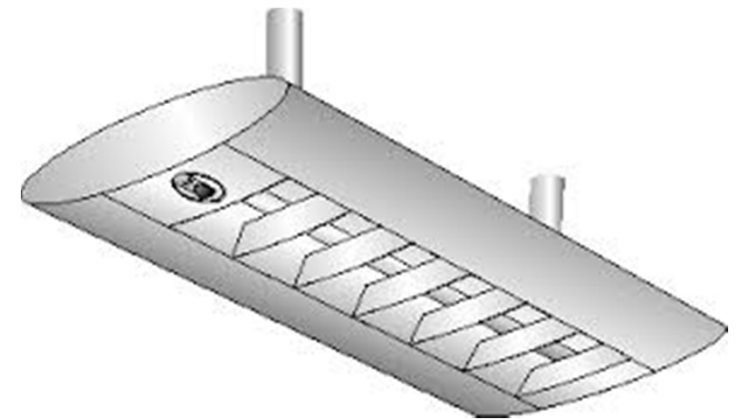

[*Levermore, G. J., 2000. *Building Energy Management Systems: Application to Low-energy HVAC and Natural Ventilation Control*, 2nd ed., E & FN Spon, London & New York]



Further Reading

- Levermore, G. J., 2000. *Building Energy Management Systems: Application to Low-energy HVAC and Natural Ventilation Control*, 2nd ed., E & FN Spon, London & New York. [696 L661 b]
 - Chapter 12 Low-energy air conditioning and lighting control
- Chilled Beams and Chilled Ceilings
 - <http://archtoolbox.com/materials-systems/hvac/120-chilled-beam-ceiling.html>
- Displacement ventilation -- Wikipedia
 - http://en.wikipedia.org/wiki/Displacement_ventilation
- Mixed mode / hybrid ventilation [BUILD connection online]
 - <http://www.build.com.au/mixed-mode-hybrid-ventilation>