



## Building Energy Use



*Dr. Sam C. M. Hui*

Department of Mechanical Engineering

The University of Hong Kong

E-mail: [cmhui@hku.hk](mailto:cmhui@hku.hk)

# Contents

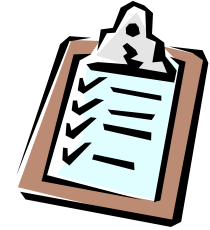

- Energy Use in Buildings
- Energy Efficiency
- Submetering
- Demand Analysis
- Load Inventory



# Energy Use in Buildings

- Buildings constitute 30% to 60% of total energy needs in a society
  - Residential + commercial + industrial buildings
  - The potential for energy saving is large
  - About 90% of total electricity consumption in Hong Kong is contributed by buildings\*
- Electricity generation contributes 67% of total greenhouse gas (GHG) emission in Hong Kong in 2008

# Greenhouse gas (GHG) emission trends of Hong Kong 1990-2008

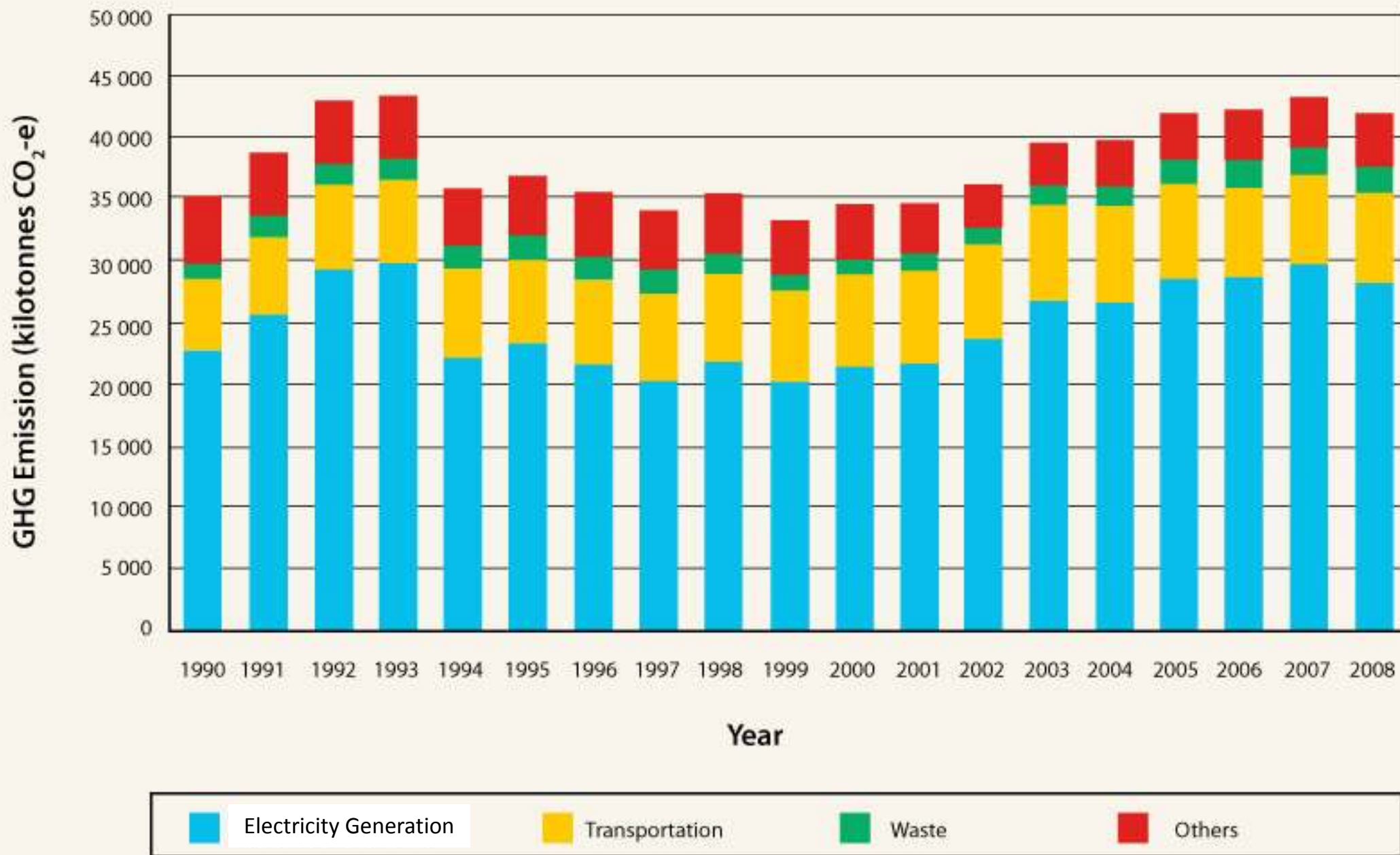

# Greenhouse gas (GHG) emission of Hong Kong 2008

Hong Kong's greenhouse gases emission by sectors in 2008<sup>14</sup>



Note: Other end use of fuel including use of fuel for combustion in commercial, industrial and domestic premises



Hong Kong's electricity consumption by sectors in 2008<sup>15</sup>



Which ones are related to buildings?

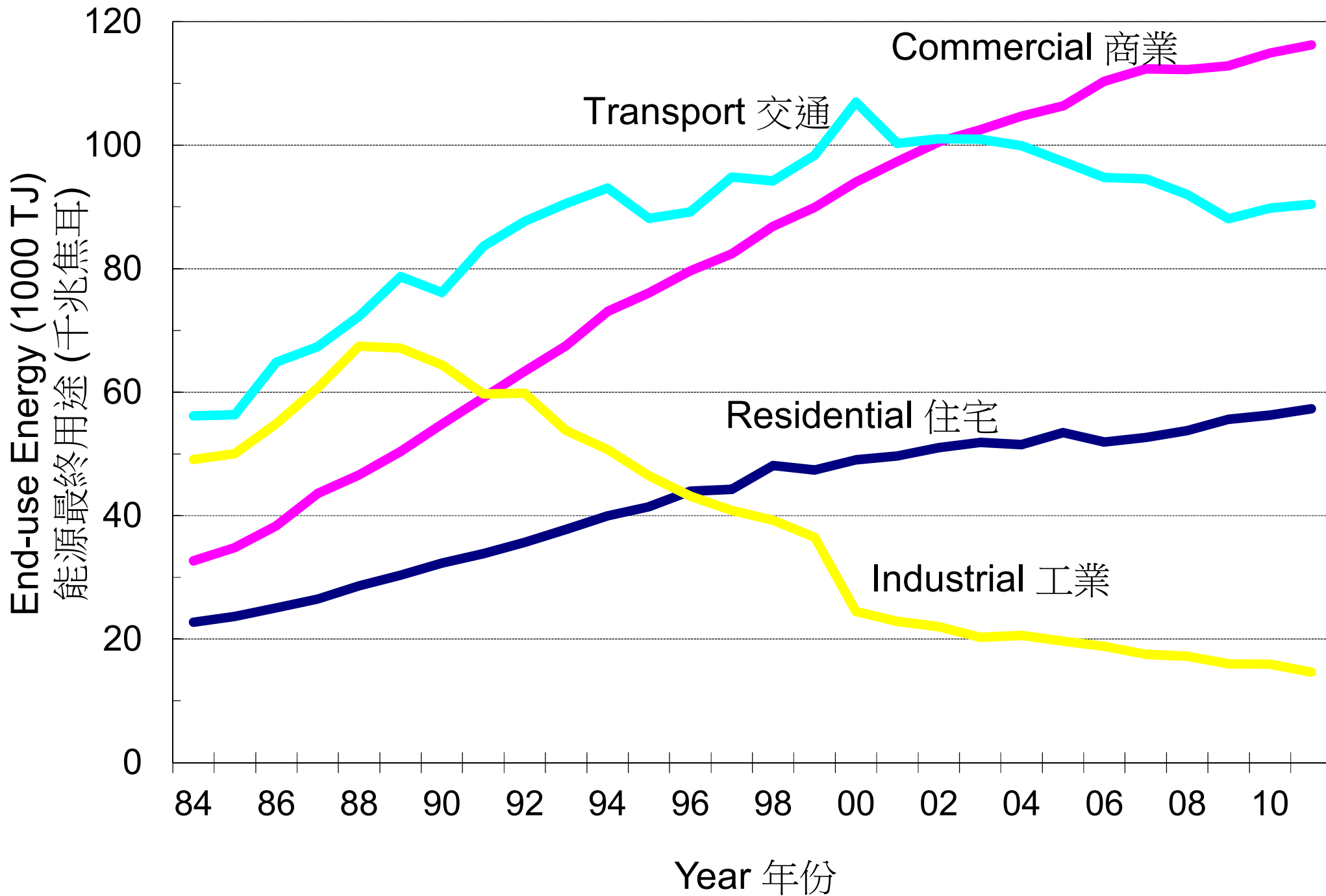

(Data source: EMSD) Energy end-use in Hong Kong by sectors, 1984-2011

# Energy end-use by sector in Hong Kong (2011)

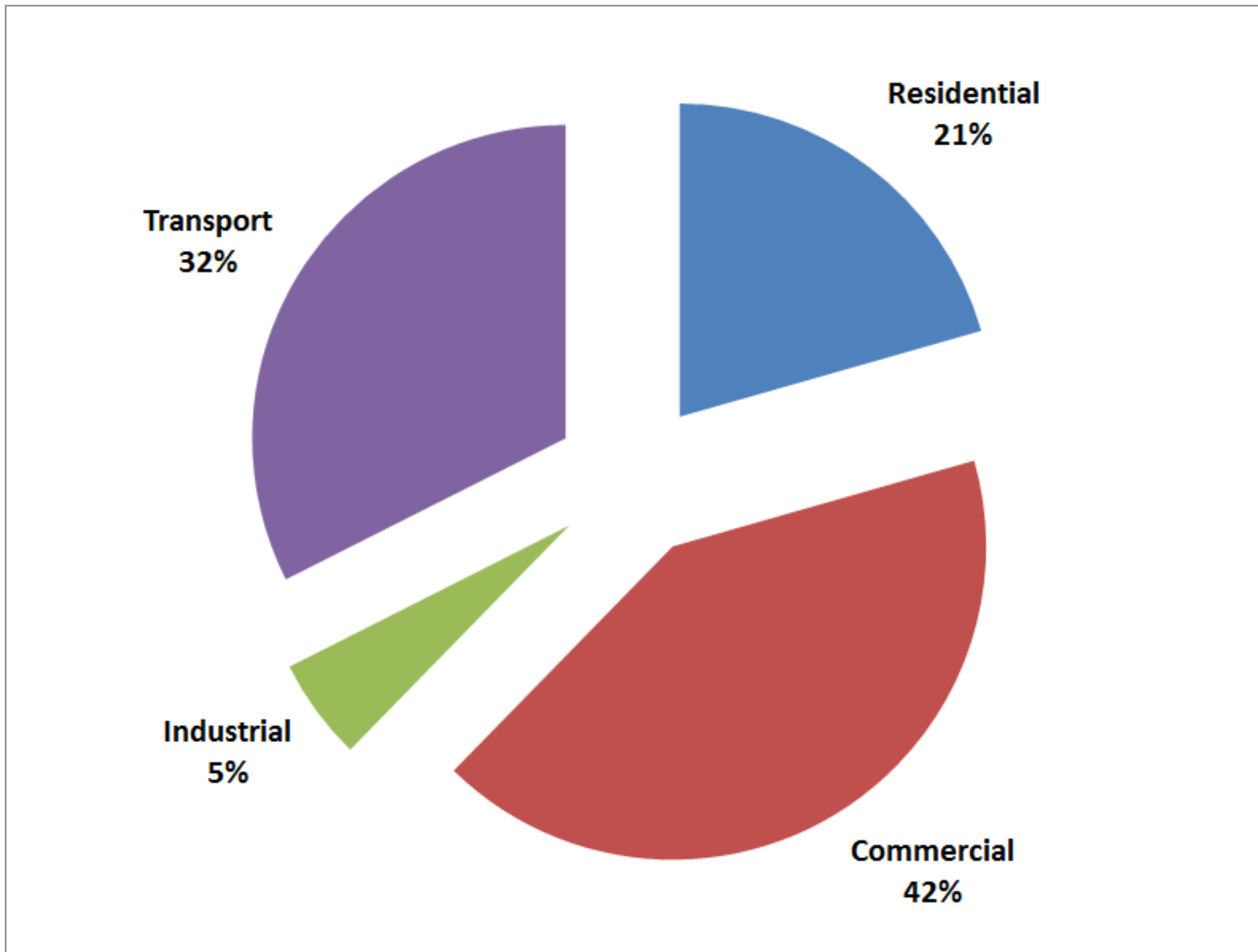

(Data source: EMSD)

**Table 1 - Final energy requirements (FER)  
in Hong Kong (year 2012)**

Unit: MJ	Commercial	Residential	Industrial	Total
Electricity	102 440 (66%)	41 189 (27%)	11 282 (7%)	154 911 (100%)
Town gas	11 555 (41%)	15 473 (54%)	1 331 (5%)	28 360 (100%)
Elec. + town gas	113 995	56 662	12 613	183 270
% in total FER	38.2%	19.0%	4.1%	61.4%

Total FER for 2012 = 298 414 TJ

(\* Data Source: *Hong Kong Energy Statistics 2012 Annual Report*)



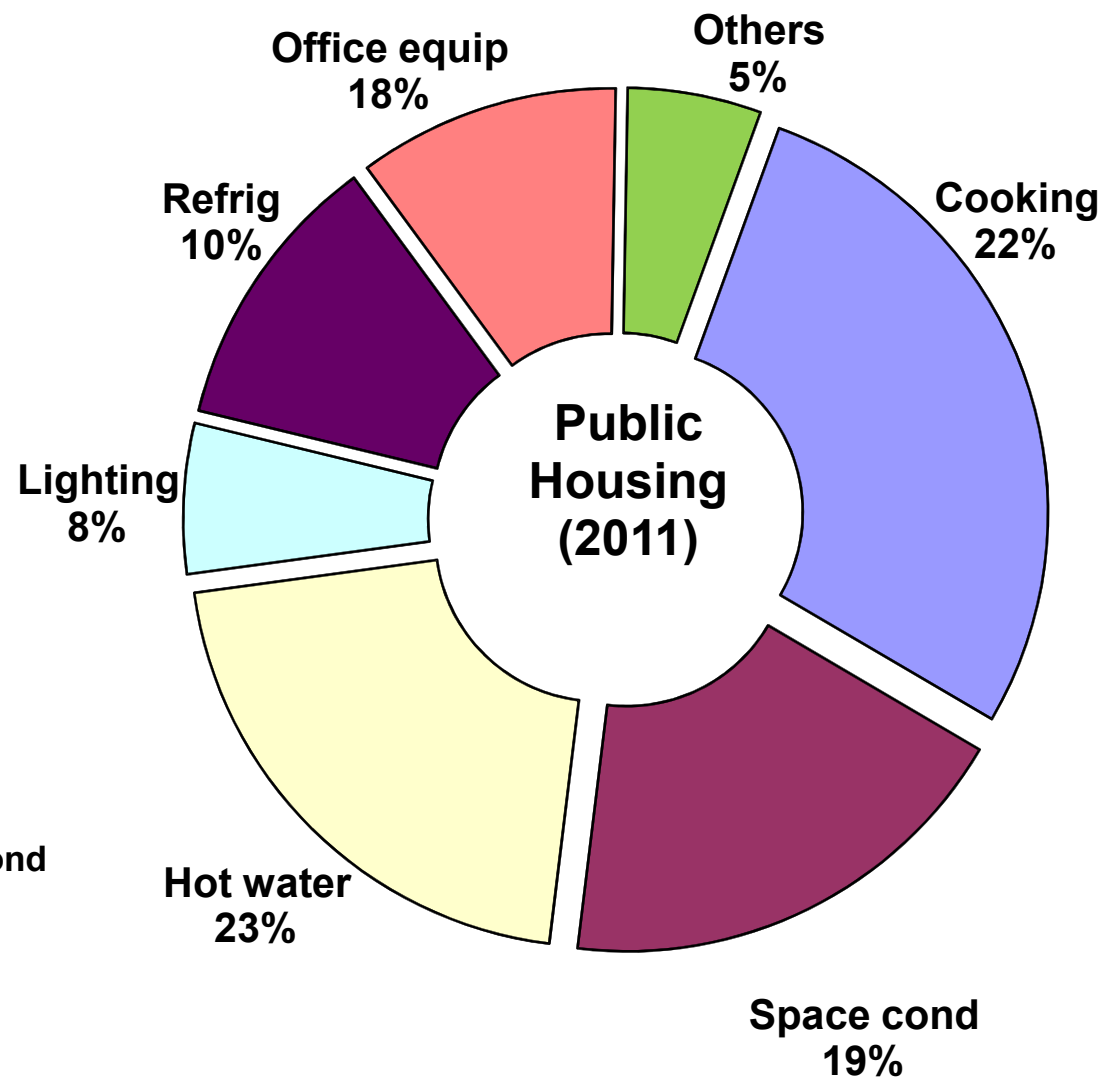
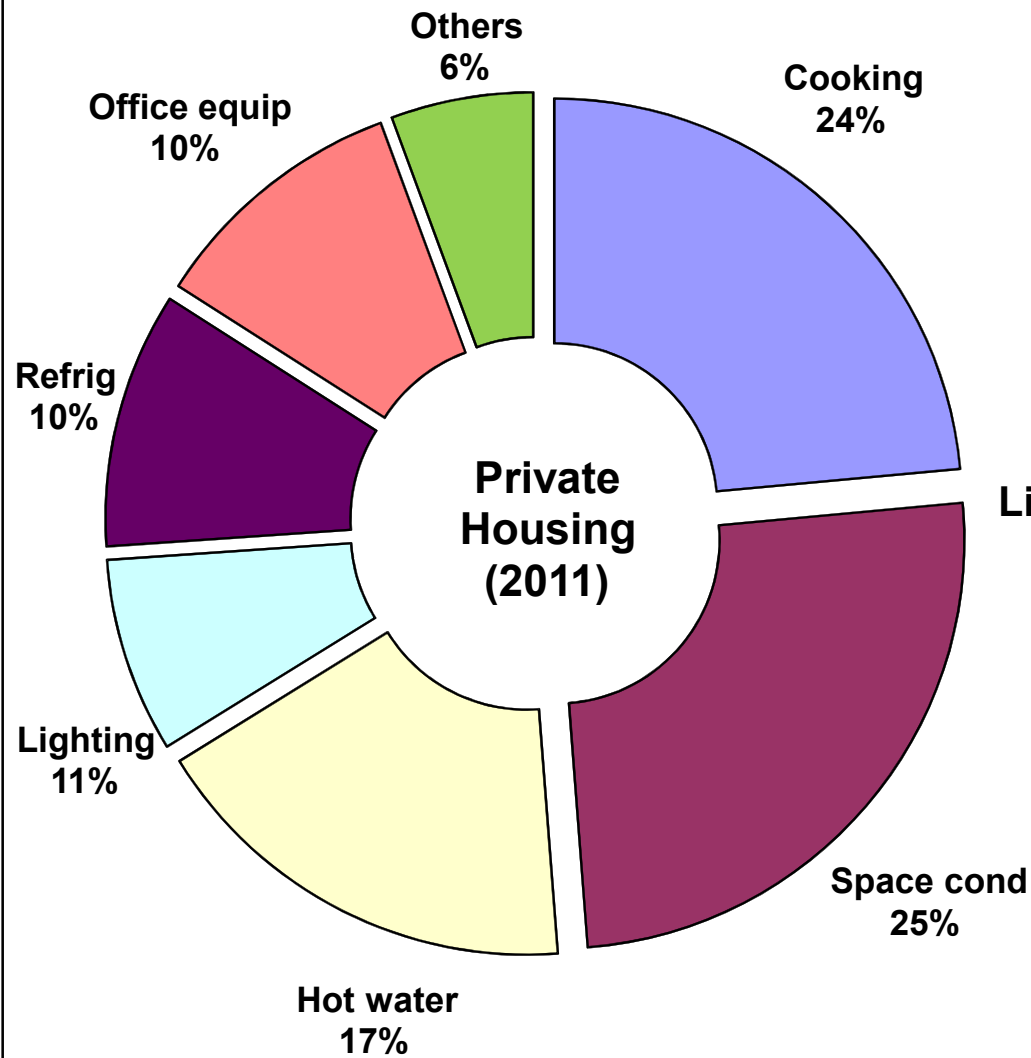

Energy consumption patterns in residential buildings  
 (Data source: Energy Efficiency Office, HK)

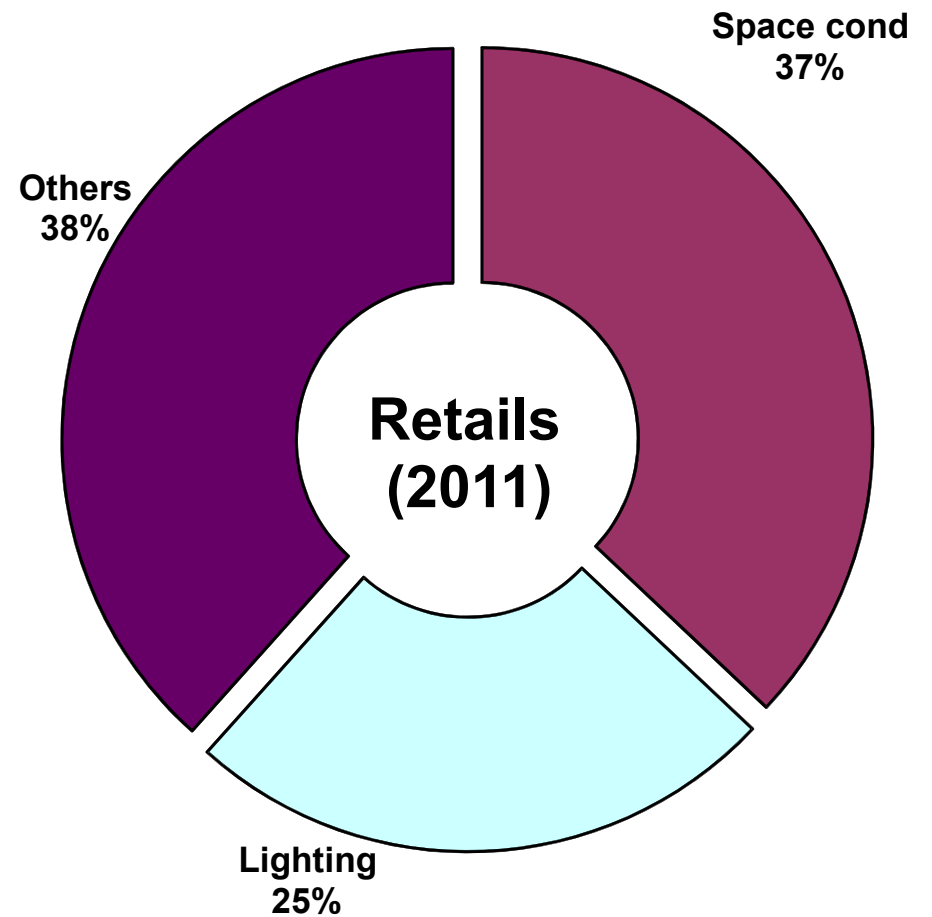
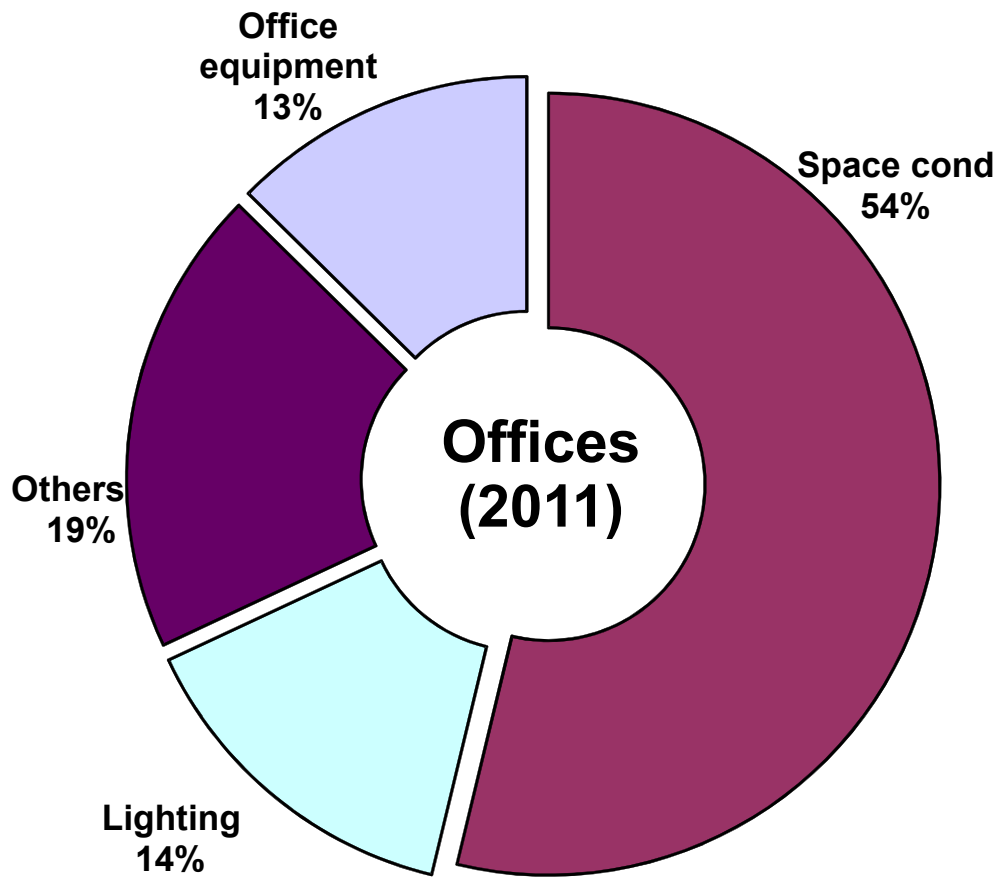

Energy consumption patterns in offices and retails  
(Data source: Energy Efficiency Office, HK)

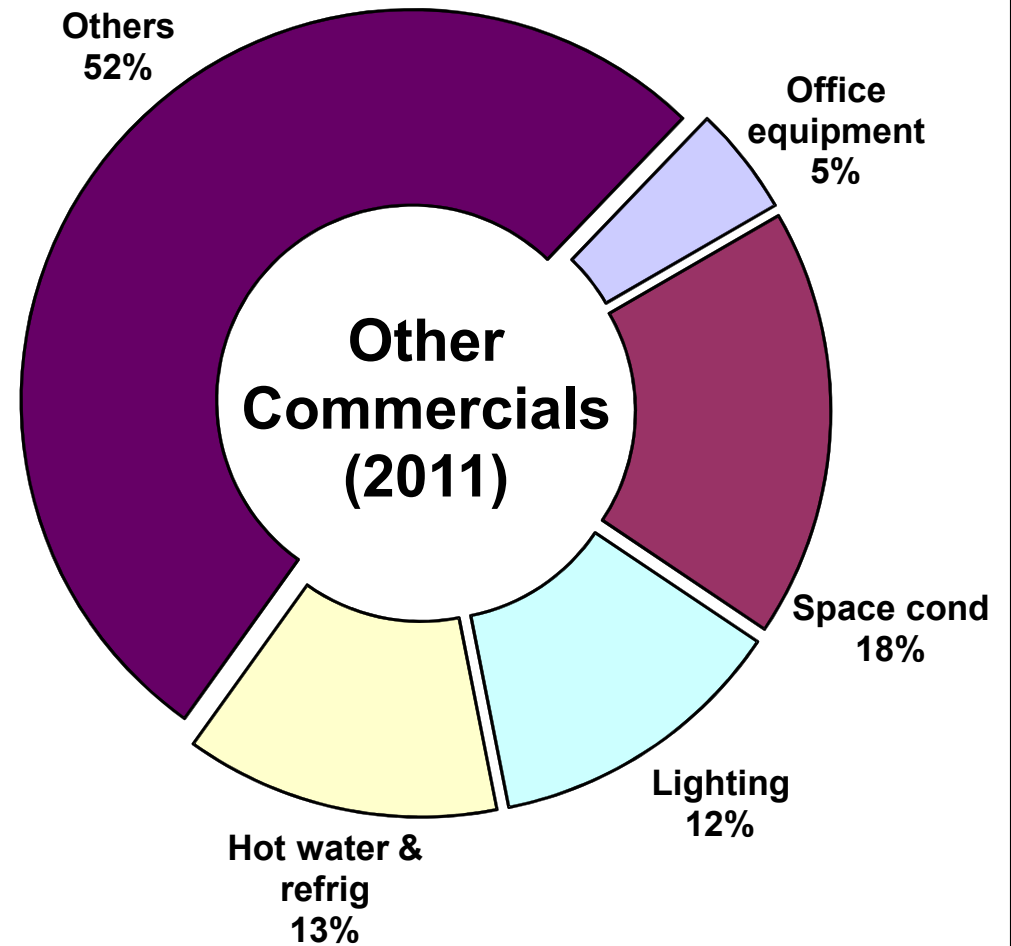
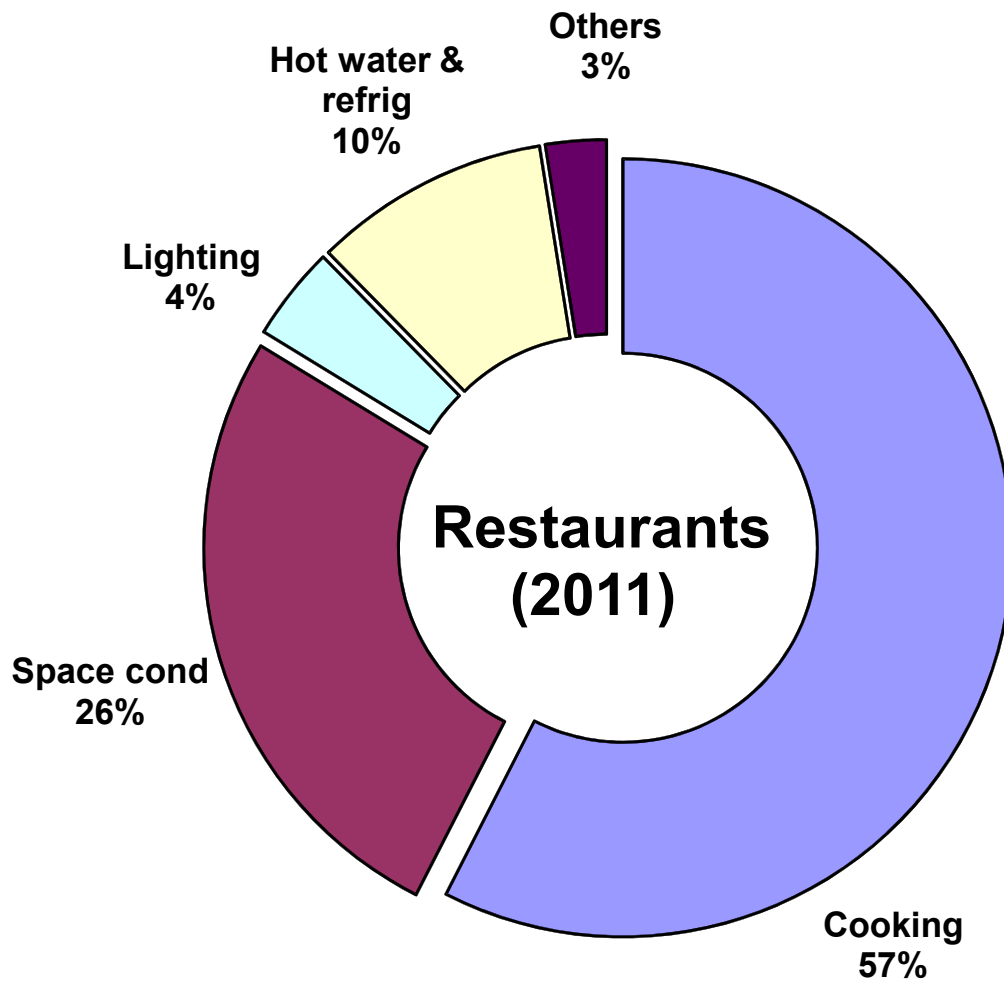

Energy consumption patterns in other commercial buildings  
(Data source: Energy Efficiency Office, HK)

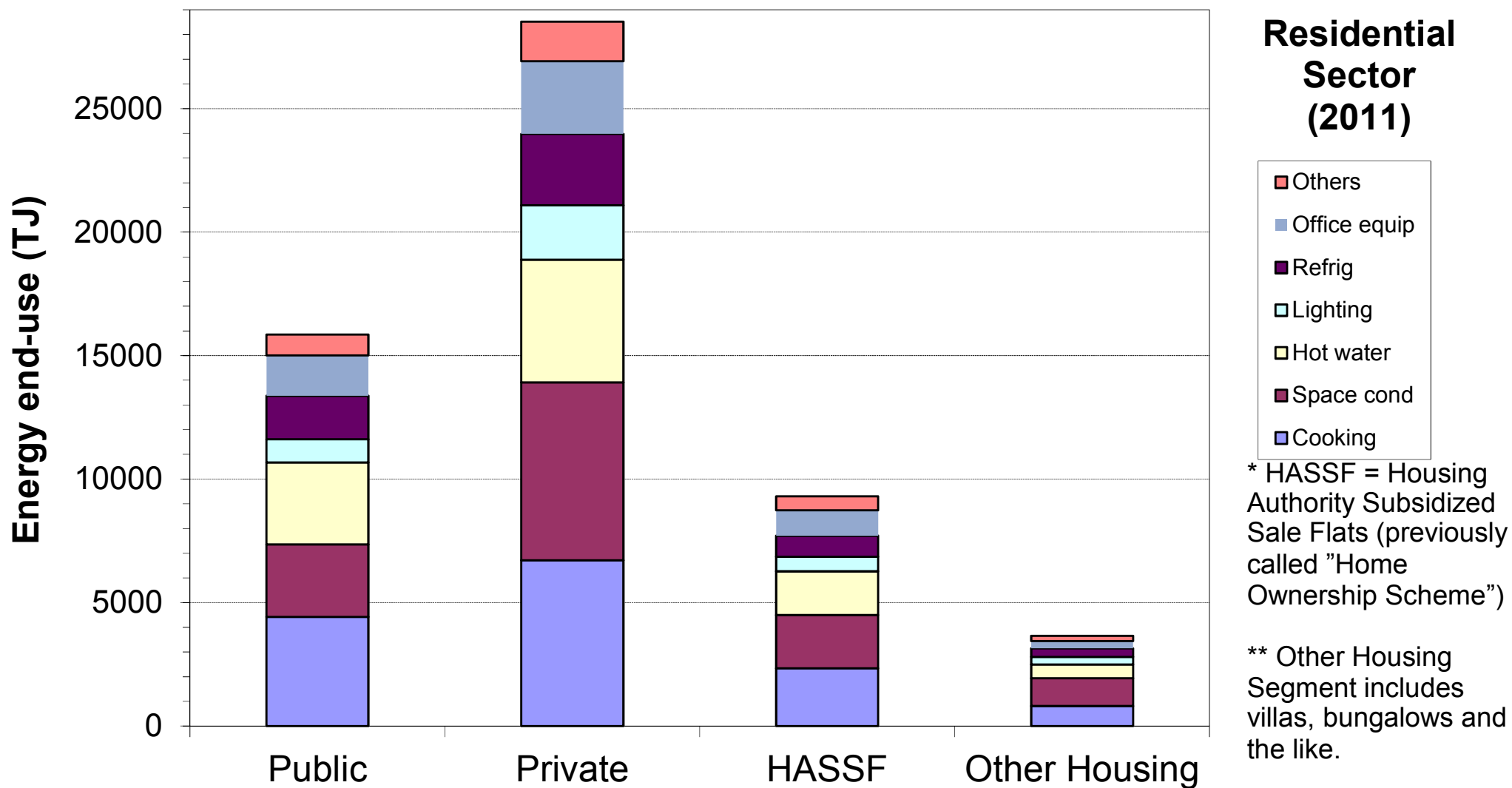

Energy end-use in residential sector, 2011  
(Data source: Energy Efficiency Office, HK)

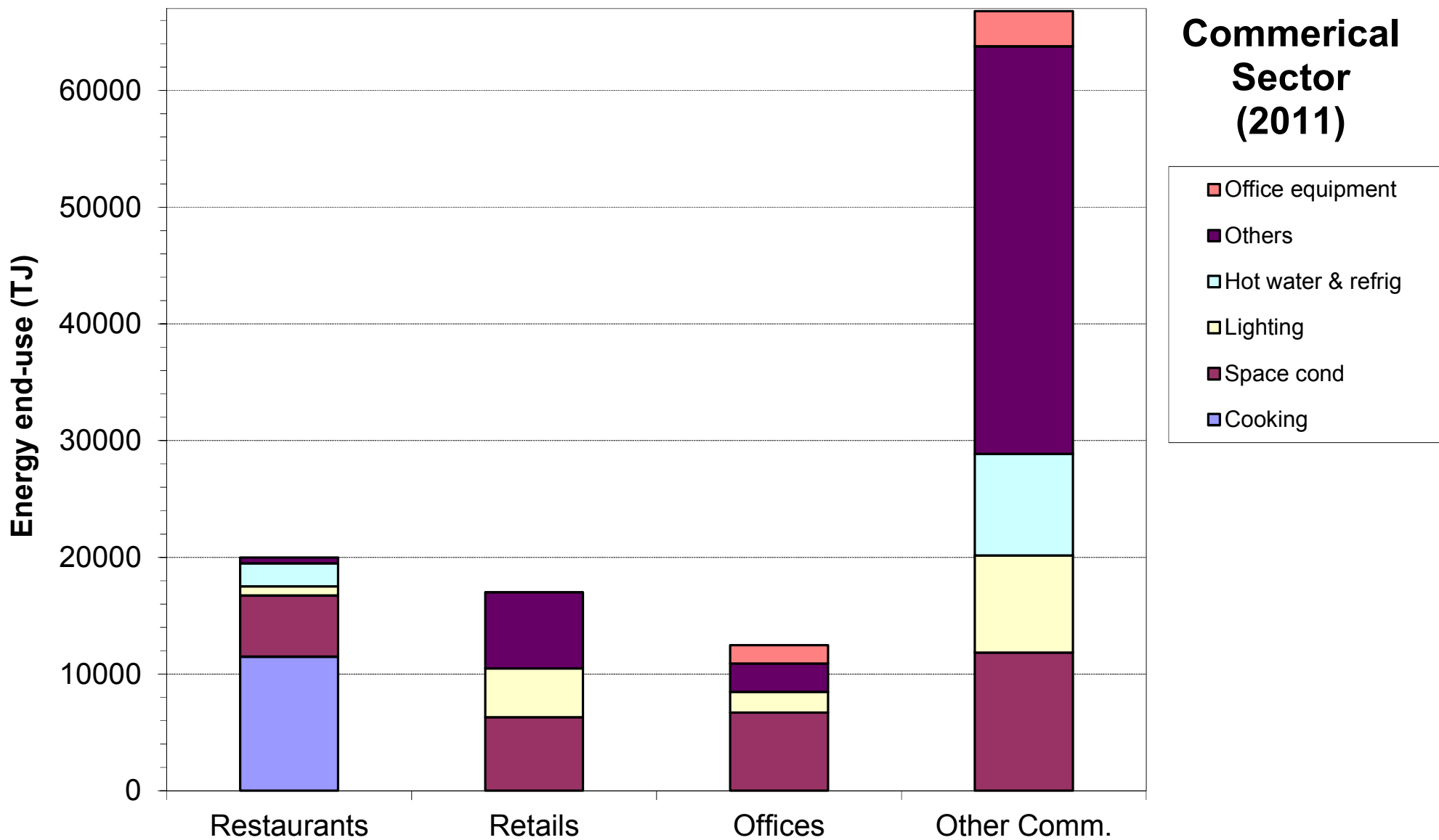

Energy end-use in commercial sector, 2011  
 (Data source: Energy Efficiency Office, HK)

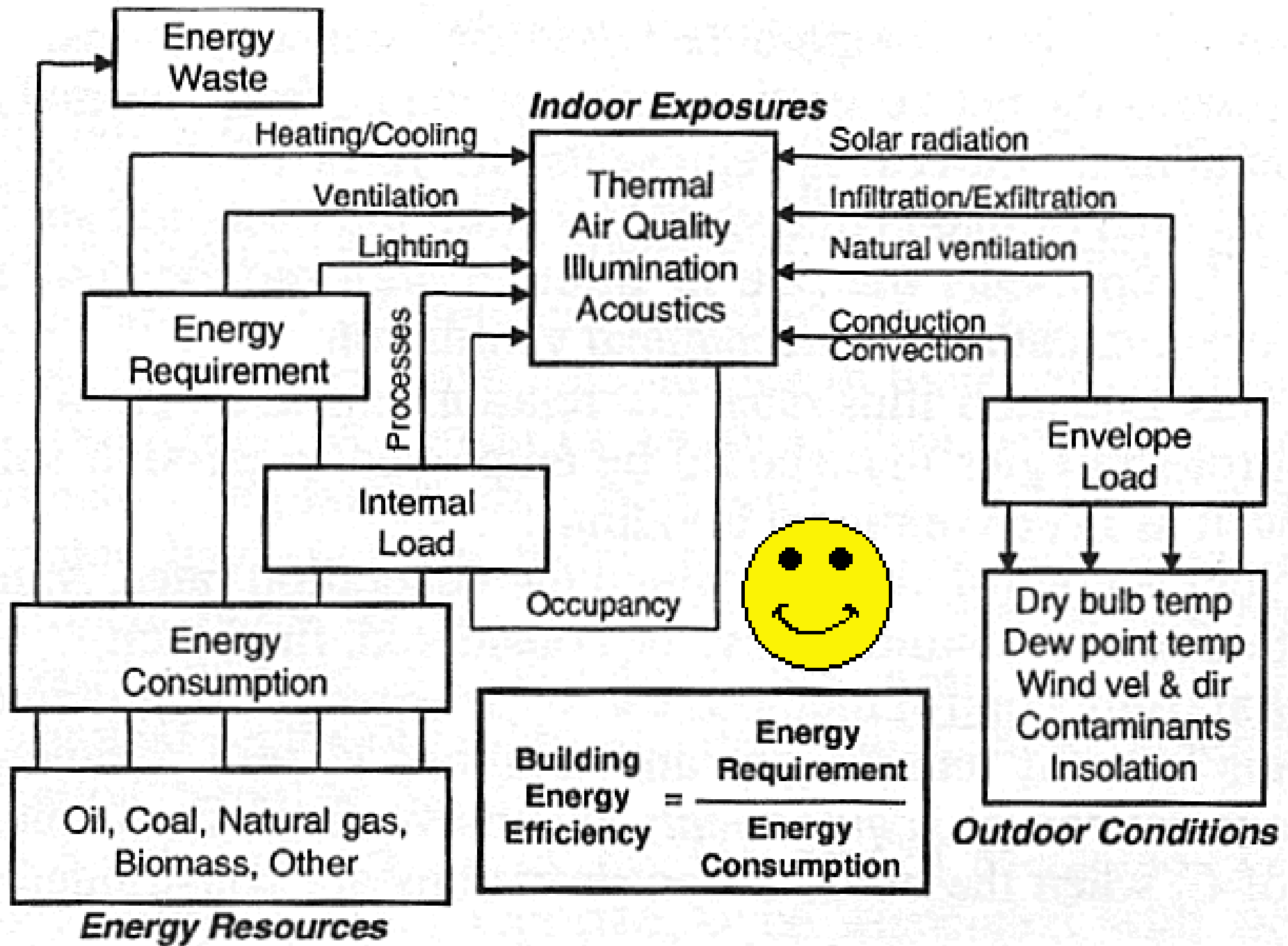

Energy flow and concept in buildings

# Energy Use in Buildings



- Possible benefits from energy efficiency:
  - 1. Improved building design and operation
  - 2. Better working environments
  - 3. Life-cycle cost savings
  - 4. Added market value of buildings
  - 5. Reduced CO<sub>2</sub> emissions and consumption of finite fossil fuels
  - 6. Reduced capital cost by better integration of building fabric and systems

# Energy efficiency potential used by sector: a huge opportunity going unrealised

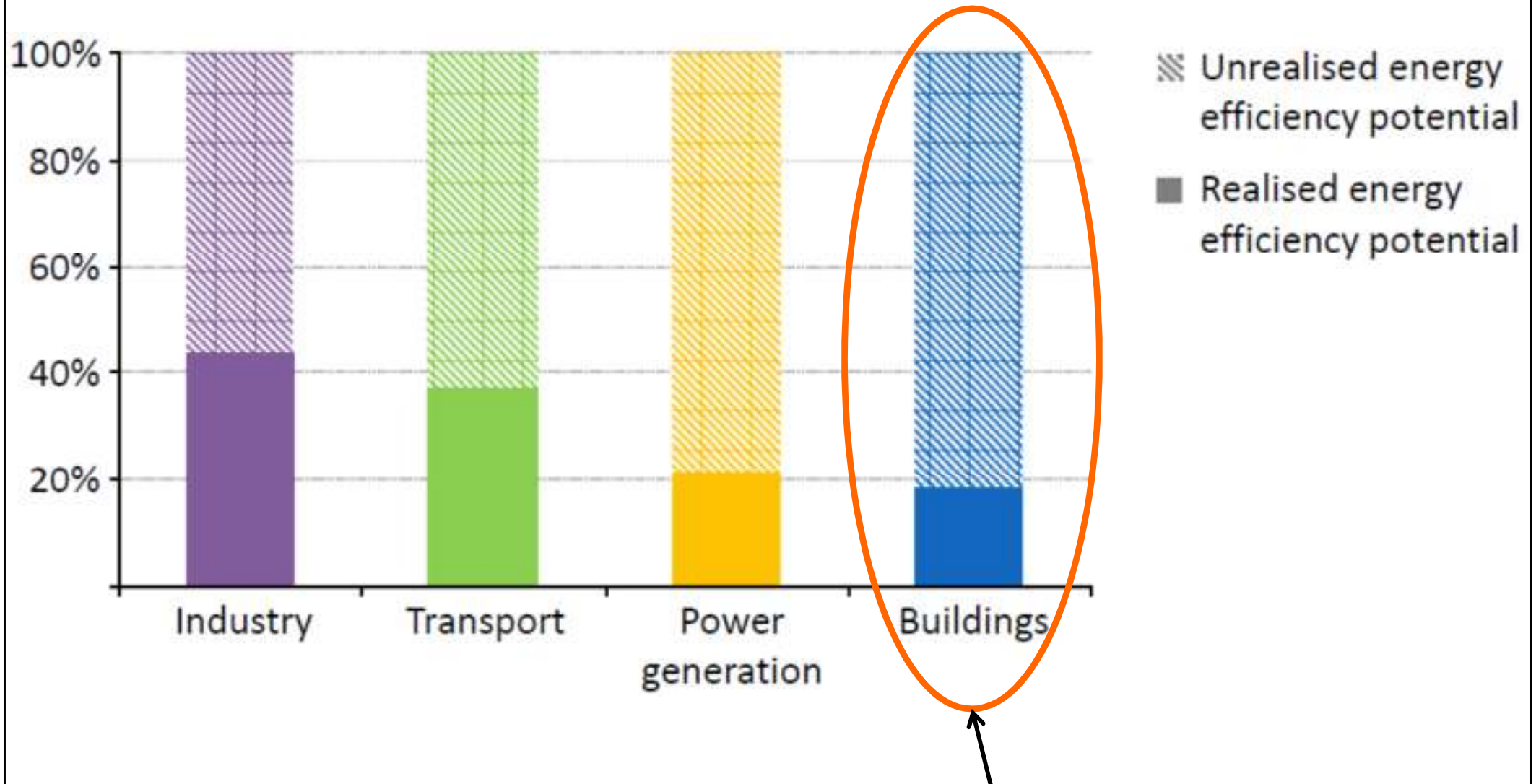

The building sector has the largest potential





# Energy Efficiency

- Key persons in building energy efficiency
  - Building Developer or Owner (Client)
  - Architect
  - Building Services Engineer
  - Building/Facility Manager
  - End-Users





# Energy Efficiency

- For new buildings
  - Designing the building
    - Design strategy
    - Control strategies
    - Commissioning
- For existing buildings
  - Operating and upgrading the building
    - Building management
    - Refurbishment/renovation/retrofitting
    - Maintenance and monitoring

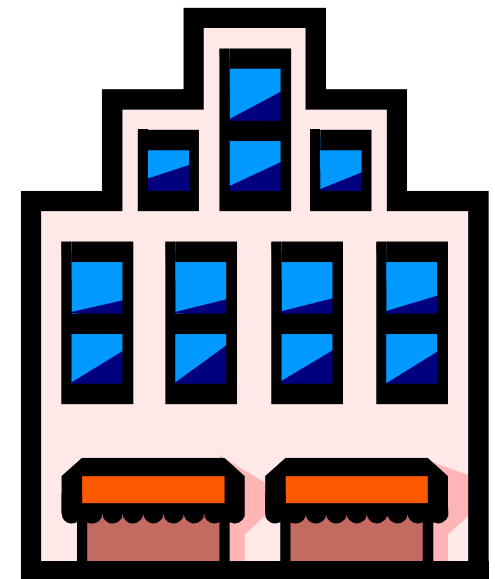



# Energy Efficiency

- Energy efficiency is greatly affected by building management, operation and maintenance (O&M)
  - Key to energy efficient management of existing buildings
    - A sound understanding of the building
    - A clear energy management & maintenance policy
    - Clear organisational structures & roles
    - Encourage & motivate the occupants
    - Set energy targets & continually monitor performance

Good design practices

Integrated & total energy approach

Efficient systems

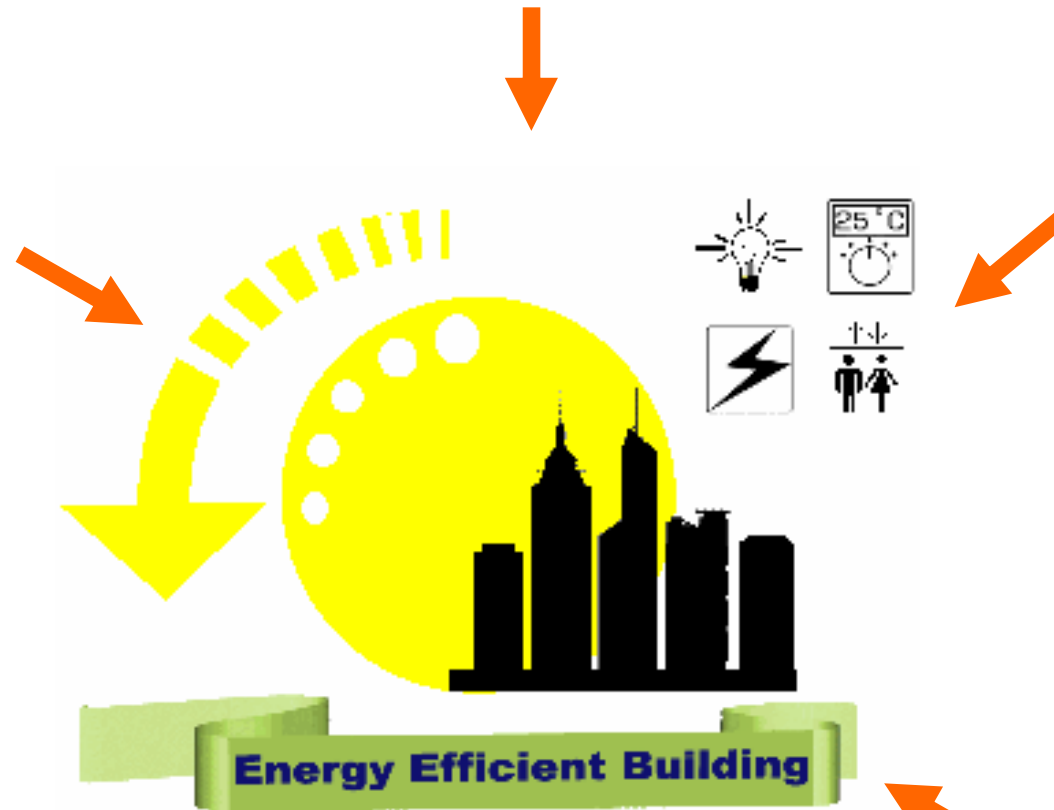

Good house-keeping

User education & awareness

Efficient operation

# Building Energy Management Systems - How much energy can be saved

Energy conservation opportunities	Estimated energy savings*
Turn up temperature to 25.5°C in summer	5% of cooling cost for each °C raised
Turn back temperature to 20°C in winter	9% of heating cost for each °C set back
Maintain air-conditioning units by annual check-ups and adjustments	15% of cooling cost
Maintain furnace at maximum efficiency by annual check-ups and adjustments	10% of heating cost
Set back domestic water heater from 60 to 43°C	6-12% of hot water cost
Maximise use of daylight	50-60% of lighting cost
Improve lighting maintenance	10% of lighting cost
Turn off unnecessary lights	17% of lighting cost
Reduce lighting	15-28% of lighting in existing buildings 25-50% of lighting in new buildings
Use insulating glass	10-13% of cooling and heating costs
Insulate hot water pipes and storage tanks	15% of water heating costs
Provide adequate insulation for roof	20% of cooling and heating costs

(\* For typical examples only)

# Submetering



- What is submetering?
  - Defined as a metering device installed after the main utility meter
    - Used for capturing facility energy data at a specific location, panel, circuit or user
  - Delivers granularity (breakdown) of facility energy performance data

***Submeters –The critical component for accessing facility energy related data***

# What is Submetering?

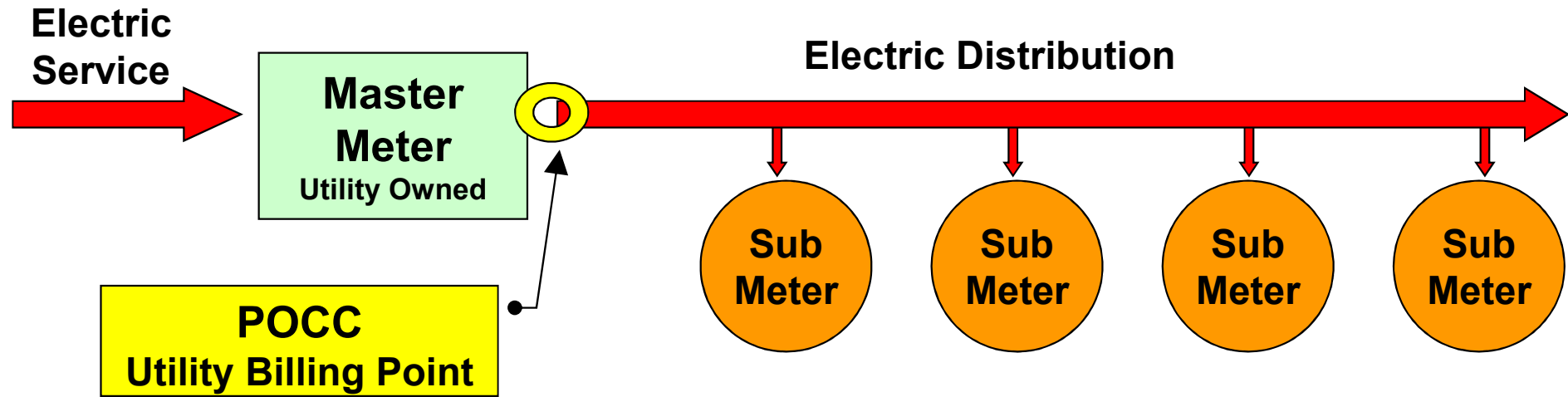

**POCC** – Point of Common Coupling, the point where control passes from the Electric Utility to the building Owner

Electricity meter



Gas meter



Water meter



Also chilled, hot water & steam meters

# Submetering



- Electro-Mechanical Meter

- Typical utility type meter
- Available in various amperages
- Power passes through meter, then to distribution panel
- Requires substantial physical space for installation
- One meter per building
  - Restricted ability to sell multiple meters per customer site

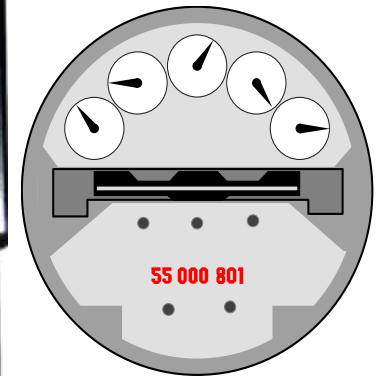



# Submetering



- Sensor-Based Submeters

- Non-socket, current sensor based technology

- Limited or no power interruption
- Lower installed cost
  - No current transformer (CT) cabinets
  - No meter socket
  - Reduced cabling and conduit
- 1/10 the time to install
- Space saving and flexibility in location

- Multiple submeters per location increases revenue stream

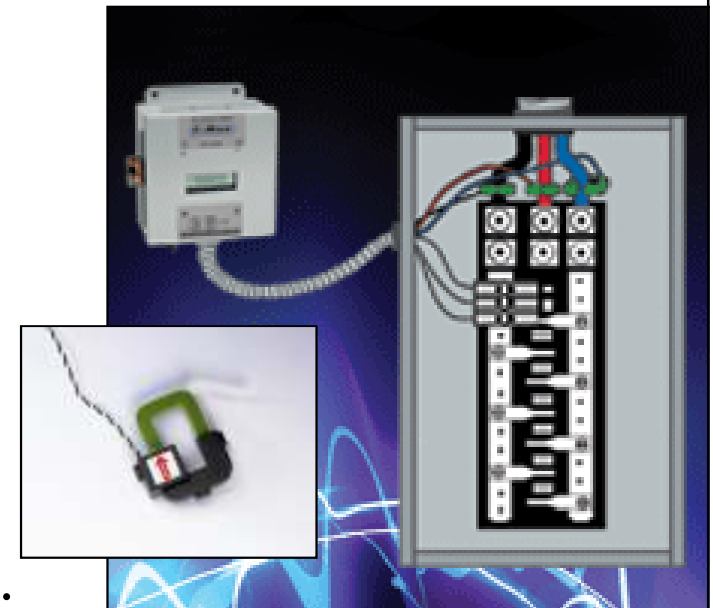

# Electronic kWh Meter Installation

1. Mount meter at desired location
2. Connect voltage inputs – fuse/provide disconnect according to code
3. Install split-core current sensors
4. Power up meter

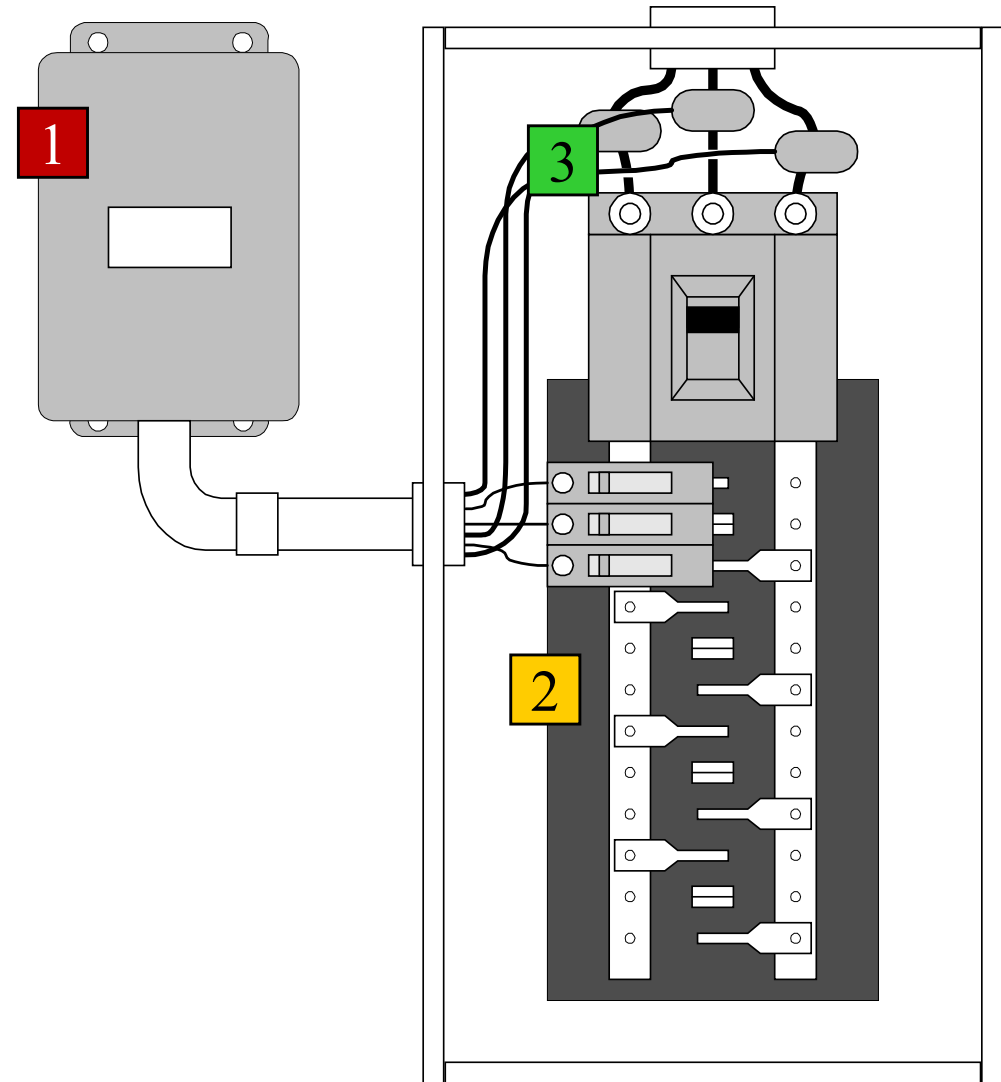

Three major components of energy usage:

- (a) HVAC
- (b) Lighting
- (c) Receptacle loads

# Submetering



- Accurate energy monitoring
  - Electronic submetering equipment: ease and flexibility of installation



- Metering installs in practically any available space
- Any size circuit from main distribution to a single 15 amp branch can be monitored
- No changes to building wiring required
- Using split-core current sensors will allow installation without disconnecting cables

# Submetering



- Benefits of submetering:
  - Accurate energy monitoring
  - Ease and flexibility of installation
  - Concise energy management tool
  - Promotes energy savings
  - Positive environmental impact
  - Automatic Meter Reading (AMR) capable
  - Provides time of use (T.O.U.) graphs and charts

# Submetering



- Submetering easily ties into building/energy management equipment
- Detailed energy data gives system maximum control over energy usage, etc.
- Remote monitoring by Automatic Meter Reading (AMR) system acts as “watchdog” to keep an eye on performance
- Maximum control = Maximum savings

# Metering data from a BMS server made available to a local area network using an OPC server

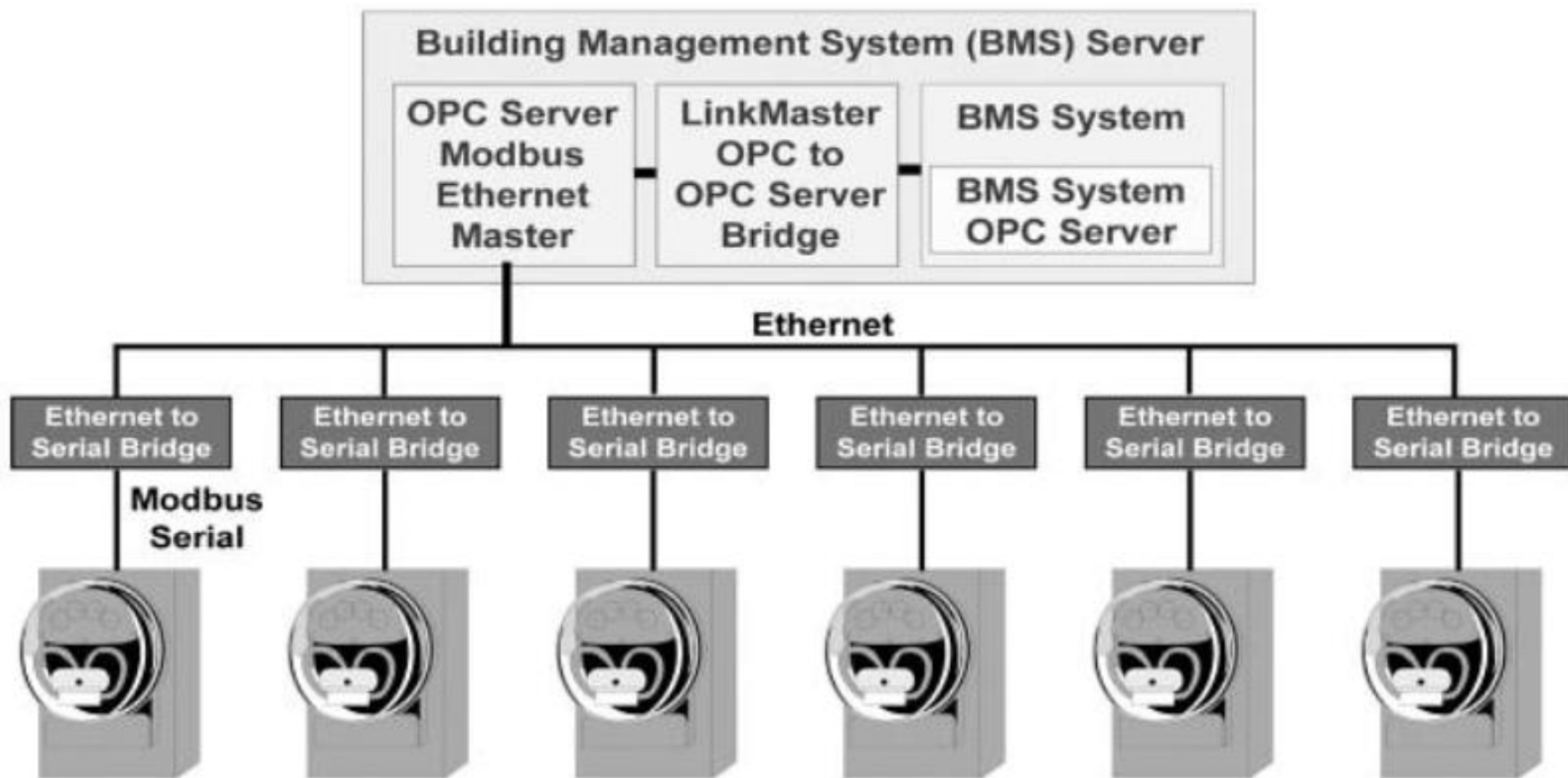

(OPC = Object Linking and Embedding (OLE) for Process Control)

# Submetering



- Promote energy management and savings
- Benchmarking
  - Accurate knowledge of where energy is being consumed is the first step in creating a savings program
- Continuous commissioning
  - Constant monitoring allows the user to gauge the results of an energy savings program

# Submetering



- Positive environmental impact
  - Better efficiency delays need for new generating facilities (costs stay lower)
  - Lower pollution provides environmentally friendly image

Each kilowatt-hour of electrical energy saved reduces pollution by:

- ☞ 0.62 kg carbon dioxide (CO<sub>2</sub>)
- ☞ 5.8 grams sulphur dioxide (SO<sub>2</sub>)
- ☞ 2.5 grams nitrous oxides (NO<sub>x</sub>)



# Submetering



- Automatic meter reading (AMR)



- Allows reading of meters at any time, day or night
- Allows meter reading in all weather conditions
- Allows reading of meters anywhere in the world from your computer
- AMR provides “time-of-use” data
  - For “real-time” pricing of energy
  - For event analysis
  - For demand side management programs
  - For energy program planning and performance analysis

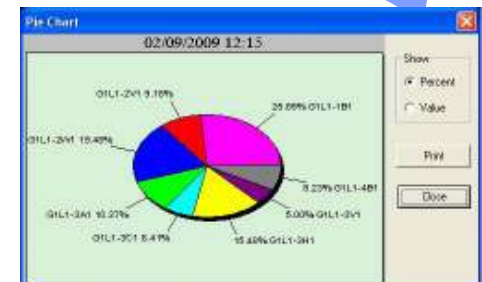

# System architecture of automatic meter reading (AMR) of Towngas

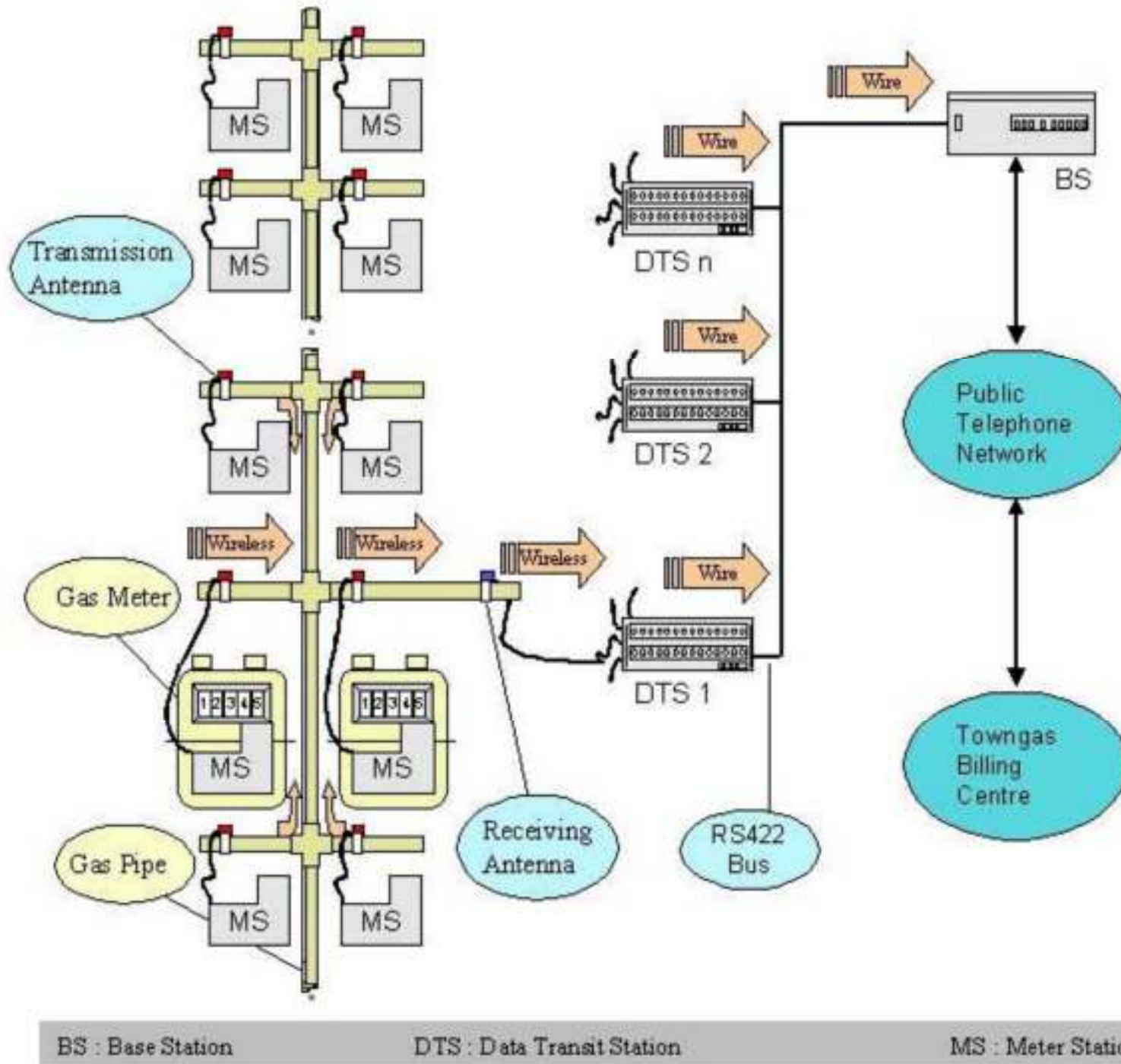

# Submetering



- Advanced Metering

- Advanced meters (or “smart” meters)



- Have the capability to measure and record interval data (at least hourly for electricity), and communicate the data to a remote location in a format that can be easily integrated into an advanced metering system

- Advanced metering systems (AMS)

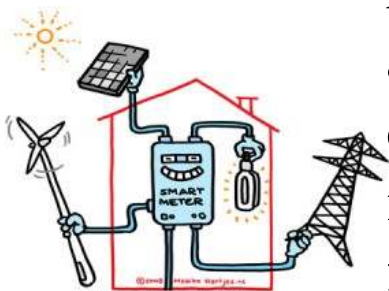

- A system that collects time-differentiated energy usage data from advanced meters via a network system on either an on-request or defined schedule basis. It is capable of providing usage information on at least a daily basis and can support desired features and functionality related to energy use management, procurement, and operations

(\* See also [http://en.wikipedia.org/wiki/Smart\\_meter](http://en.wikipedia.org/wiki/Smart_meter))

# Advanced metering systems and infrastructure

## Drive-by meter reader

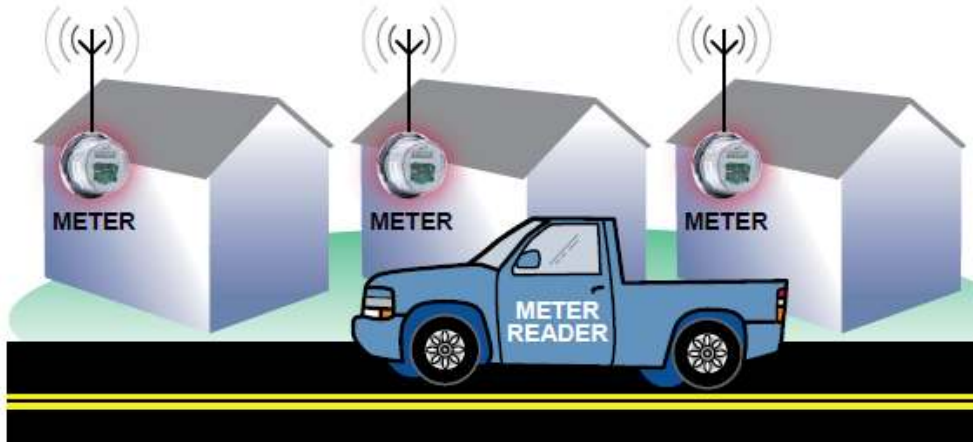

## AMR-enabled utility meter

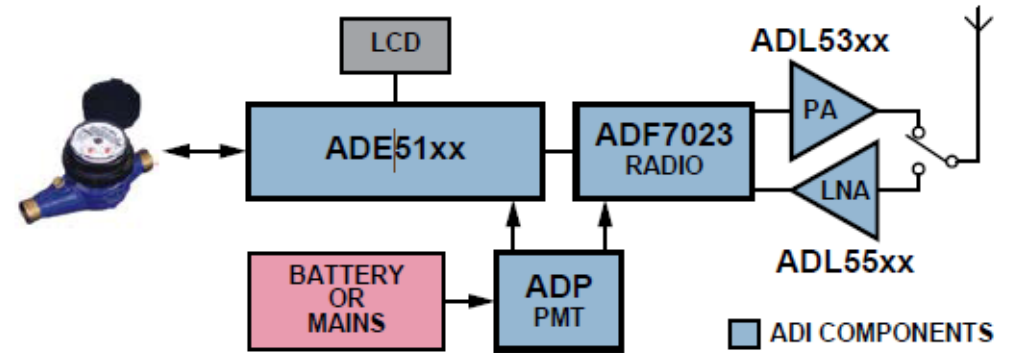

## “Smart grid” and home area network (HAN) using communication-enabled meter

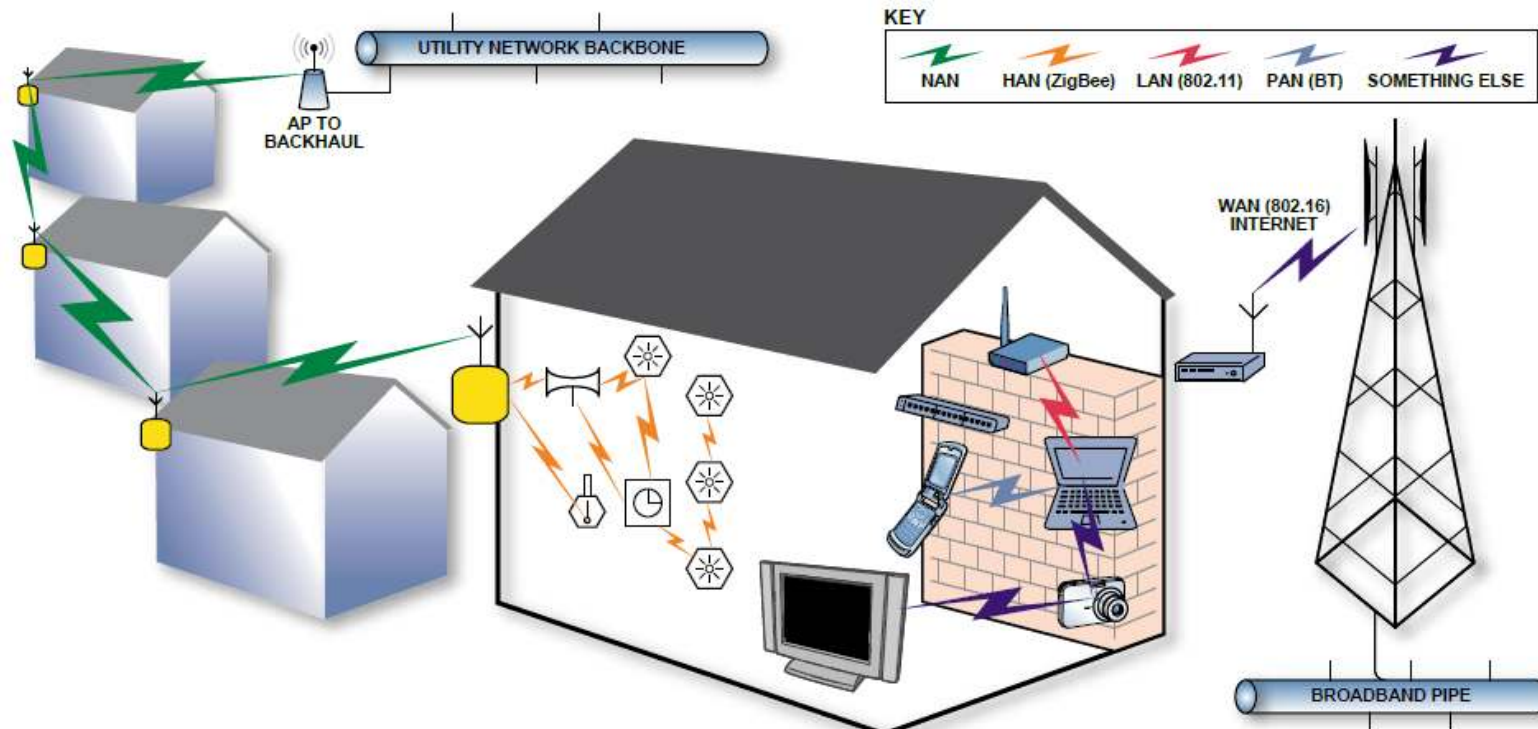

# Using wireless ethernet WiFi networking for submetering

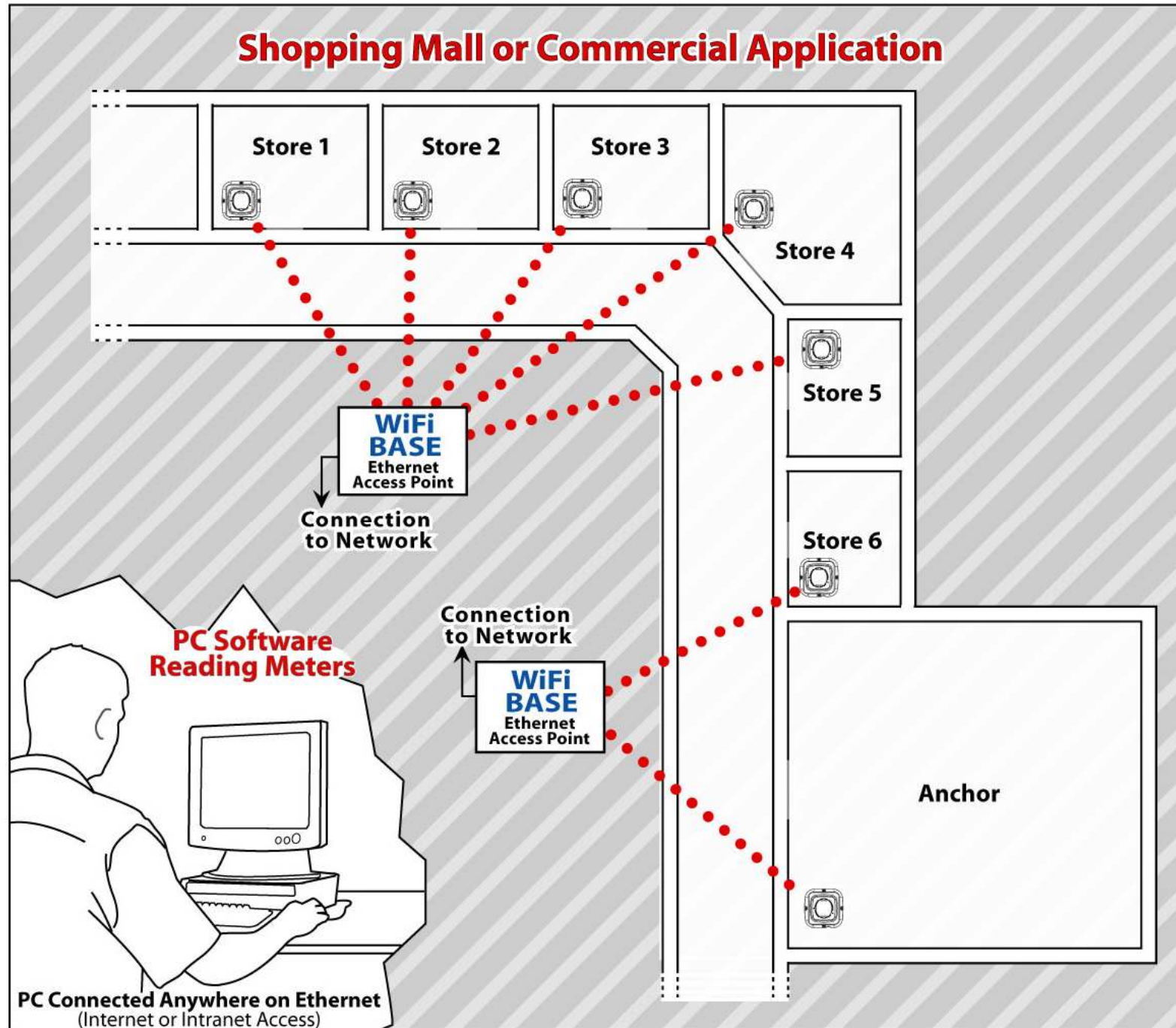

# Submetering



- Uses of metered data
  - Energy billing and procurement
    - Measure tenant energy use, verify utility bills, identify best utility rate tariffs, and participate in demand response programs
  - Measure, verify, and optimize performance
    - Diagnose equipment and systems operations; benchmark utility use; identify potential retrofit/replacement projects; and monitor, diagnose, and communicate power quality problems

# Submetering



- Uses of metered data (cont'd)
  - Manage utility use
    - Monitor existing utility usage and utility budgeting support
  - Baseline development and measurement and verification (M&V) of savings
    - Such as in energy savings performance contracts (ESPC) and utility energy services contracts (UESC)
  - Promote energy use awareness for building managers and occupants

# Example of analysing the electricity billings

## Electricity Consumption Data

Location: ABC Facility

[ C:\Project Files\Audit Manual\Spreadsheets\[Electricity Cost.xls]Electricity Consumption Data ]

Billing Date	Metered kVA	Metered kW	Power Factor	Billed kW	Energy kWh	Daily kWh	Load Factor	Demand Cost	Energy Cost	Adjust (+/-)	Sub Total	Total Cost	
01/01/99		1,800.0		1,800.0	1,006,703	30	33,557	78%	\$21,250	\$50,365	(\$11,147)	\$71,615	\$64,701
02/01/99		1,900.0		1,900.0	1,206,383	31	38,916	85%	\$22,750	\$56,441	(\$13,204)	\$79,191	\$70,607
03/01/99		1,400.0		1,400.0	842,286	28	30,082	90%	\$15,250	\$42,144	(\$9,263)	\$57,394	\$51,501
04/01/99		1,850.0		1,850.0	1,102,176	31	35,554	80%	\$22,000	\$53,315	(\$12,132)	\$75,315	\$67,606
05/01/99		1,870.0		1,870.0	1,213,021	30	40,434	90%	\$22,300	\$56,641	(\$13,252)	\$78,941	\$70,287
06/01/99		2,200.0		2,200.0	1,339,599	31	43,213	82%	\$27,250	\$60,438	(\$14,716)	\$87,688	\$78,080
07/01/99		1,560.0		1,560.0	850,195	30	28,340	76%	\$17,650	\$42,540	(\$9,438)	\$60,190	\$54,304
08/01/99		1,570.0		1,570.0	948,747	31	30,605	81%	\$17,800	\$47,467	(\$10,429)	\$65,267	\$58,677
09/01/99		1,950.0		1,950.0	1,213,798	31	39,155	84%	\$23,500	\$56,664	(\$13,308)	\$80,164	\$71,536
10/01/99		2,300.0		2,300.0	1,373,054	30	45,768	83%	\$28,750	\$61,442	(\$15,111)	\$90,192	\$80,337
11/01/99		2,100.0		2,100.0	1,347,059	31	43,454	86%	\$25,750	\$60,662	(\$14,731)	\$86,412	\$76,699
12/01/99		2,400.0		2,400.0	1,024,475	30	34,149	59%	\$30,250	\$50,984	(\$11,685)	\$81,234	\$74,418
<b>Totals/Max</b>		<b>2,400.0</b>		<b>2,400.0</b>	<b>13,467,496</b>	<b>364</b>			<b>\$274,500</b>	<b>\$639,104</b>	<b>(\$148,415)</b>	<b>\$913,604</b>	<b>\$818,752</b>

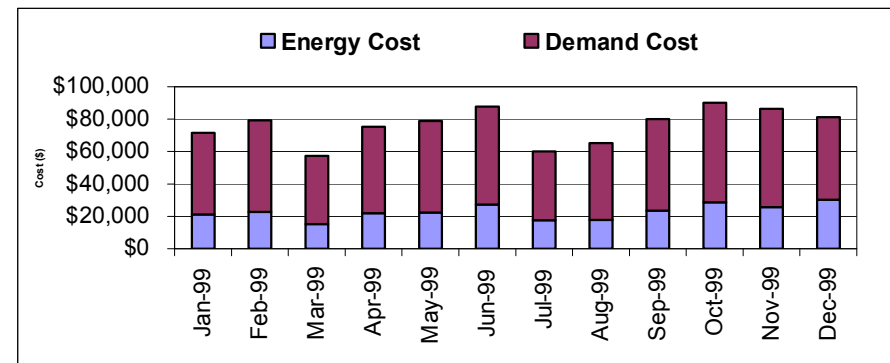
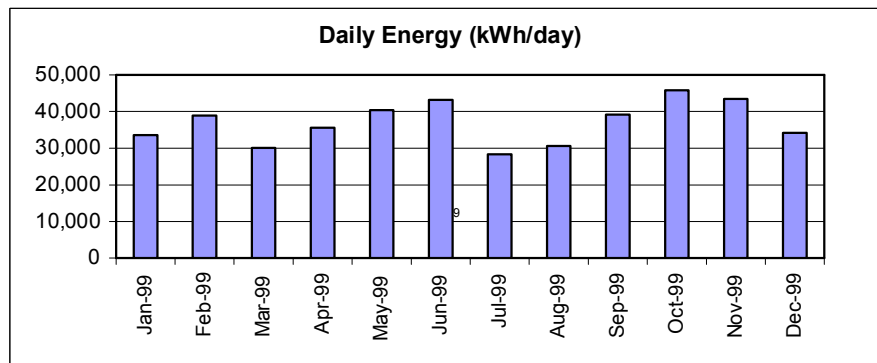
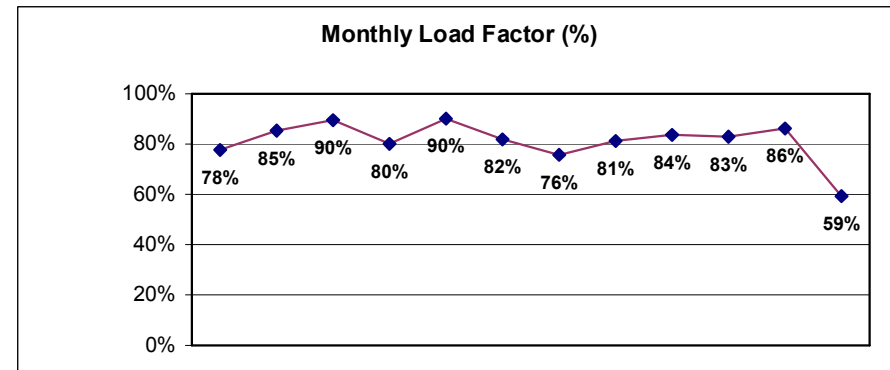
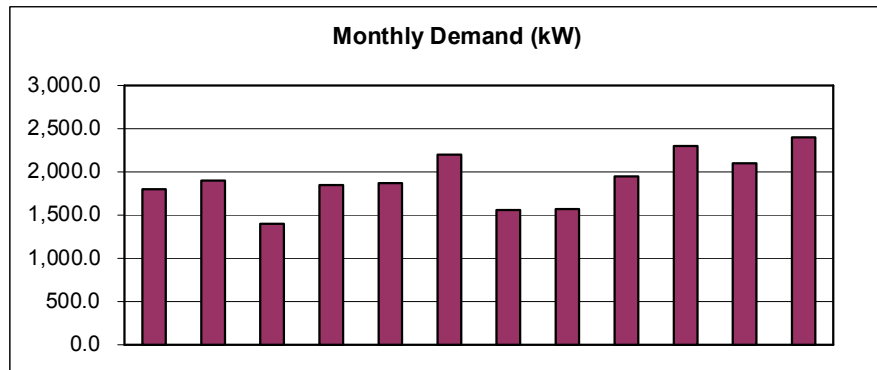



# Comparing predicted energy use and benchmark data for lighting system

## LIGHTING SYSTEM

### Key

Actual data  
(predicted)

Benchmark  
data

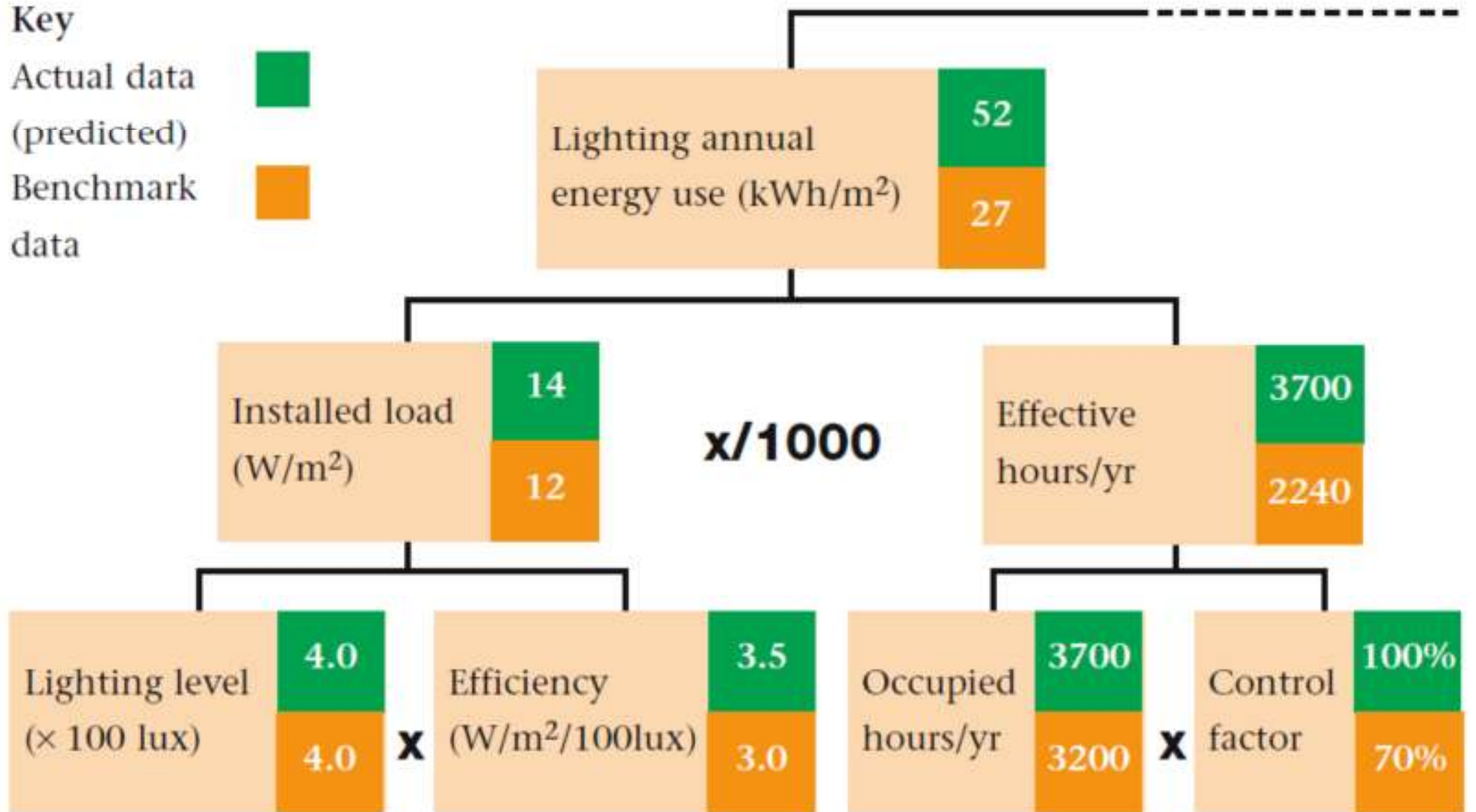

# Estimated energy usage breakdown in an example building

## ELECTRICITY

684 000 kWh/yr

### LIGHTING

180 000 kWh/yr

Fluorescent throughout, with sodium for external and car park lighting

### FANS

162 000 kWh/yr

Four air handling units, a supply and extract for each floor

### PUMPS

27 000 kWh/yr

Heating, DHW and cooling pumps all on the same distribution board

### OFFICE EQUIPMENT

112 500 kWh/yr

PCs, printers, photocopiers, plus kettles, vending machines, etc

### COOLING

90 000 kWh/yr

Two central screw compressors with integral heat rejection

### COMPUTER ROOM

76 500 kWh/yr

Air-conditioned computer room

### OTHER ELECTRICITY AND CATERING

36 000 kWh/yr

Ovens plus dishwasher supplied from the main DHW system

## GAS

531 000 kWh/yr

### SPACE HEATING

427 500 kWh/yr

Central high-efficiency gas boilers supplying heating and hot water

### DHW

72 000 kWh/yr

Separate central storage water heaters

### CATERING

31 500 kWh/yr

Various ovens, hobs, etc

(Source: GIL65 Metering energy use in new non-domestic buildings, [www.cibse.org/pdfs/GIL065.pdf](http://www.cibse.org/pdfs/GIL065.pdf))

# Submetering



- Positive contributions of metering:
  - Measurement & verification (M&V)
    - Use meters for base building, tenant submetering and energy system performance
  - Building Operations & Maintenance (BO&M)
    - Use meters and software system to educate staff, continuously track performance and optimize systems
  - Performance Measurement
    - Enhanced metering - use electric, water and gas meters and software system for ongoing accountability and optimization of building energy performance over time

# Submetering



- Hawthorne Effect\* (observer effect)
  - A phenomenon whereby workers improve or modify an aspect of their behavior in response to the fact of change in their environment, rather than in response to the nature of the change itself
- Example: Submetering added
  - Changes due to tenant awareness
  - Much kWh energy saved
  - Reduce CO<sub>2</sub> in atmosphere

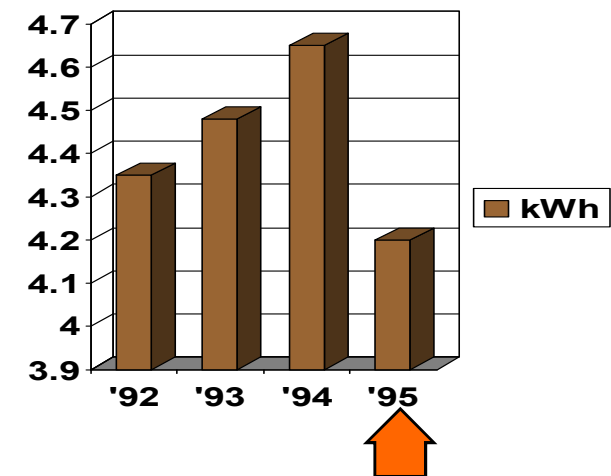

(\* See also [http://en.wikipedia.org/wiki/Hawthorne\\_effect](http://en.wikipedia.org/wiki/Hawthorne_effect))

## Metering savings ranges

Action	Observed Savings
Installation of meters	0 to 2% – initial impact, but savings will not persist
Bill allocation only	2½ to 5% – improved occupant awareness
Building tune-up and load management	5 to 15% – improved awareness, identification of simple operations and maintenance improvements, and managing demand loads per electric rate schedules
Ongoing commissioning*	15 to 45% – improved awareness, ongoing identification of simple operations and maintenance improvements, and continuing management attention

\* Commissioning: Process by which an equipment, facility, or plant (which is installed, or is complete or near completion) is tested to verify if it functions according to its design objectives or specifications

(Source: FEMP, 2006. Guidance for Electric Metering in Federal Buildings

[https://www1.eere.energy.gov/femp/pdfs/adv\\_metering.pdf](https://www1.eere.energy.gov/femp/pdfs/adv_metering.pdf))



# Demand Analysis

---

- Energy assessment and demand analysis
  - Hourly demand profile
  - Peak demand profile
- Understanding the time patterns of energy use
  - Study the electrical demand profile and identify possible energy management opportunities
  - Identify opportunities for power factor correction

# Hourly Demand Profile

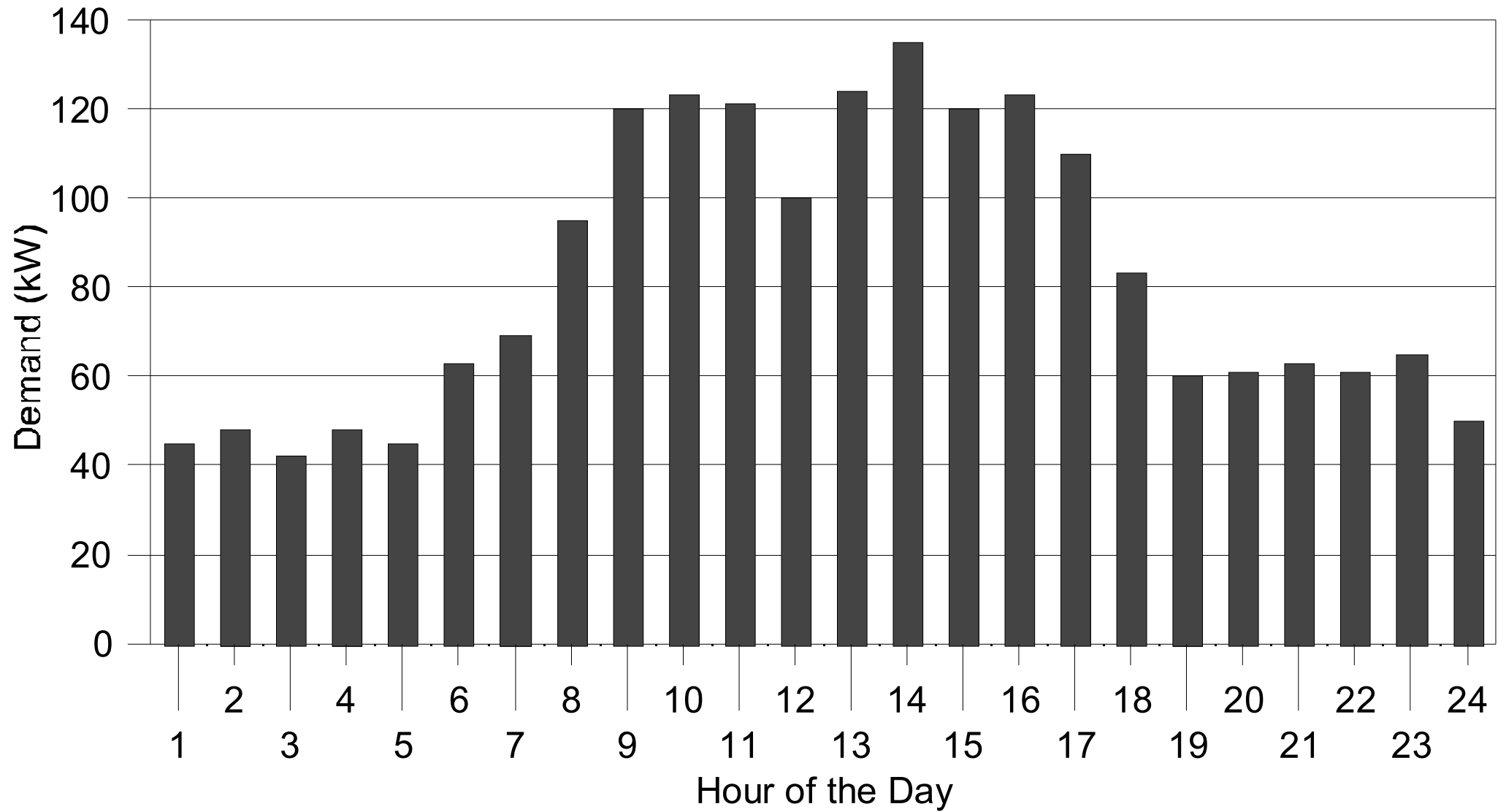

(Source: Department of Minerals and Energy, South Africa)

# An Electrical Fingerprint

## Peak Day Demand Profile

15 minute demand interval

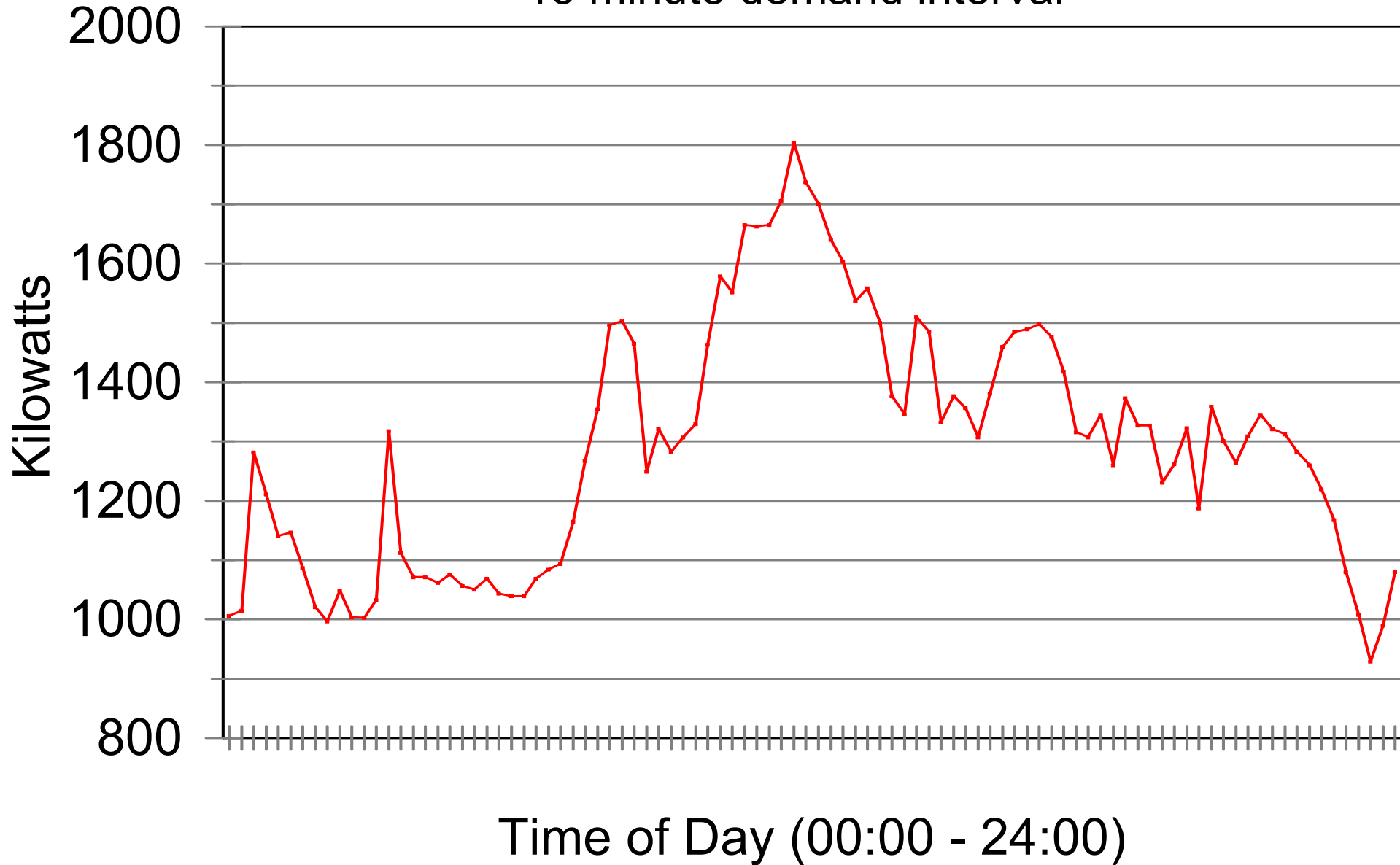





# Demand Analysis

---

- Patterns revealed:
  - Peak demand
  - Night load
  - Start-up and shut-down
  - Weather effects
  - Loads that cycle
  - Interactions
  - Occupancy effects
  - Problem areas



# Demand Analysis

- Analysing the profile
  - Requires facility operational knowledge
  - Mark scheduled events on the profile
  - Correlate events with:
    - Demand increase, decrease, cycling, peaks
  - Reconcile with demand on utility bills
  - Investigate unknown patterns

**“There’s always a savings opportunity in a new demand profile”**



# Demand Analysis

---

- Obtaining a demand profile
  - Periodic utility meter readings
  - Recording clip-on ammeter measurements
  - Basic recording power meter
  - Multi-channel recording power meters
  - A facility energy management or SCADA (supervisory control and data acquisition) system
  - A dedicated monitoring system

# Study of daily or monthly profile

## Monthly Demand Profile

15 minute demand interval

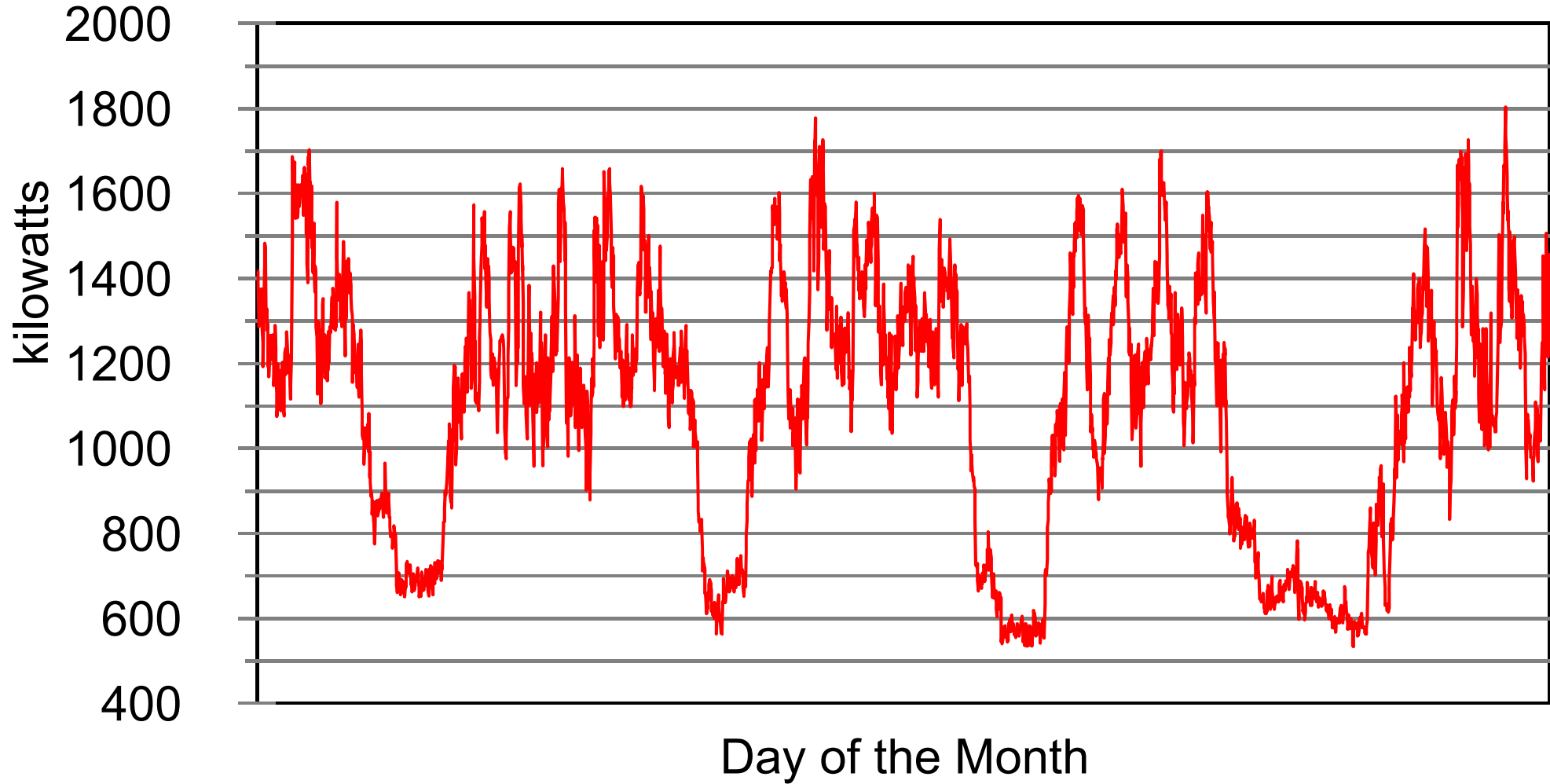

# Meter response (time delay)

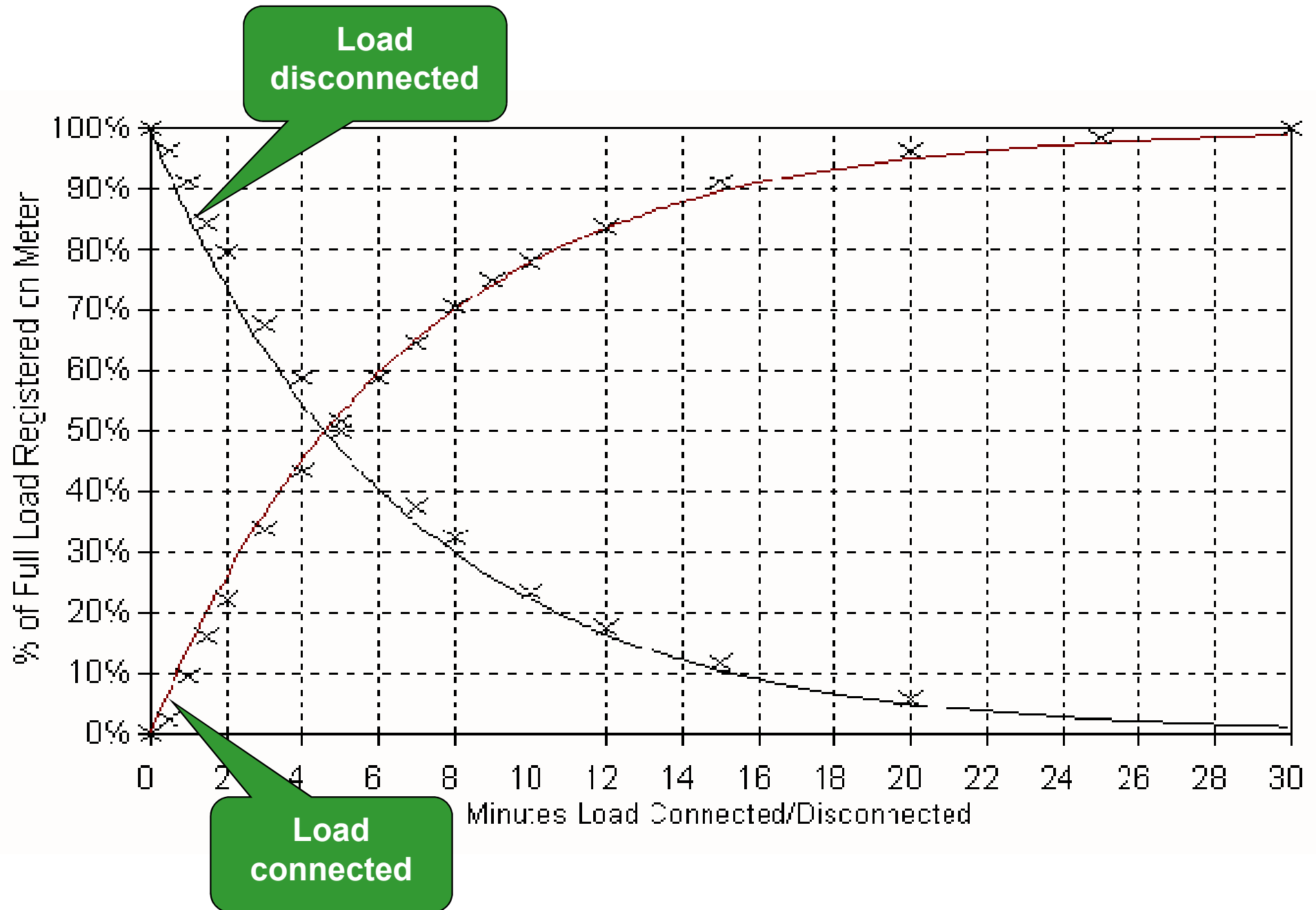

# What the demand meter sees

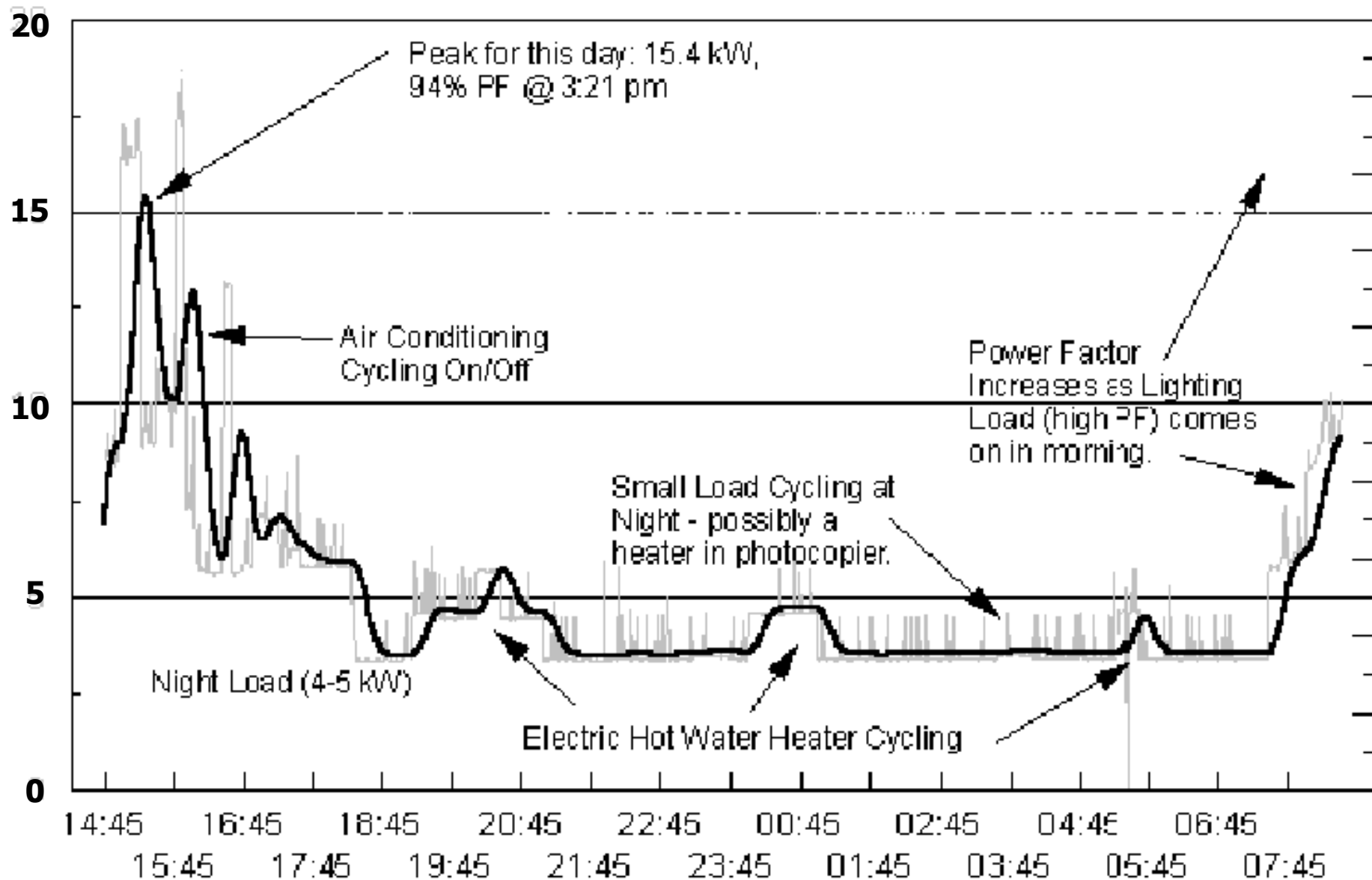



# Demand Analysis

- Savings opportunities
  - Scheduling – reduce startup peaks
  - Infrequent demand peaks – avoidable
  - Shift on-peak to off-peak usage pattern
  - Equipment loading – consider sequencing
- Correct power factor – on peak
  - At service entrance
  - In the distribution system
  - At the point of use power factor (PF)

$$P_{avg} = VI \cos \varphi$$

$$\text{POWER FACTOR} = \cos \varphi = \frac{R}{Z}$$

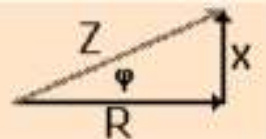



# Demand Analysis

---

- Peak demand control
  - Eliminate accidental peaks
  - Shift activity “off-peak”
  - Peak demand warning for staff
  - Interlock equipment
  - Load shedding system
  - Use generator to “clip” the peak



# Can you analyse this?

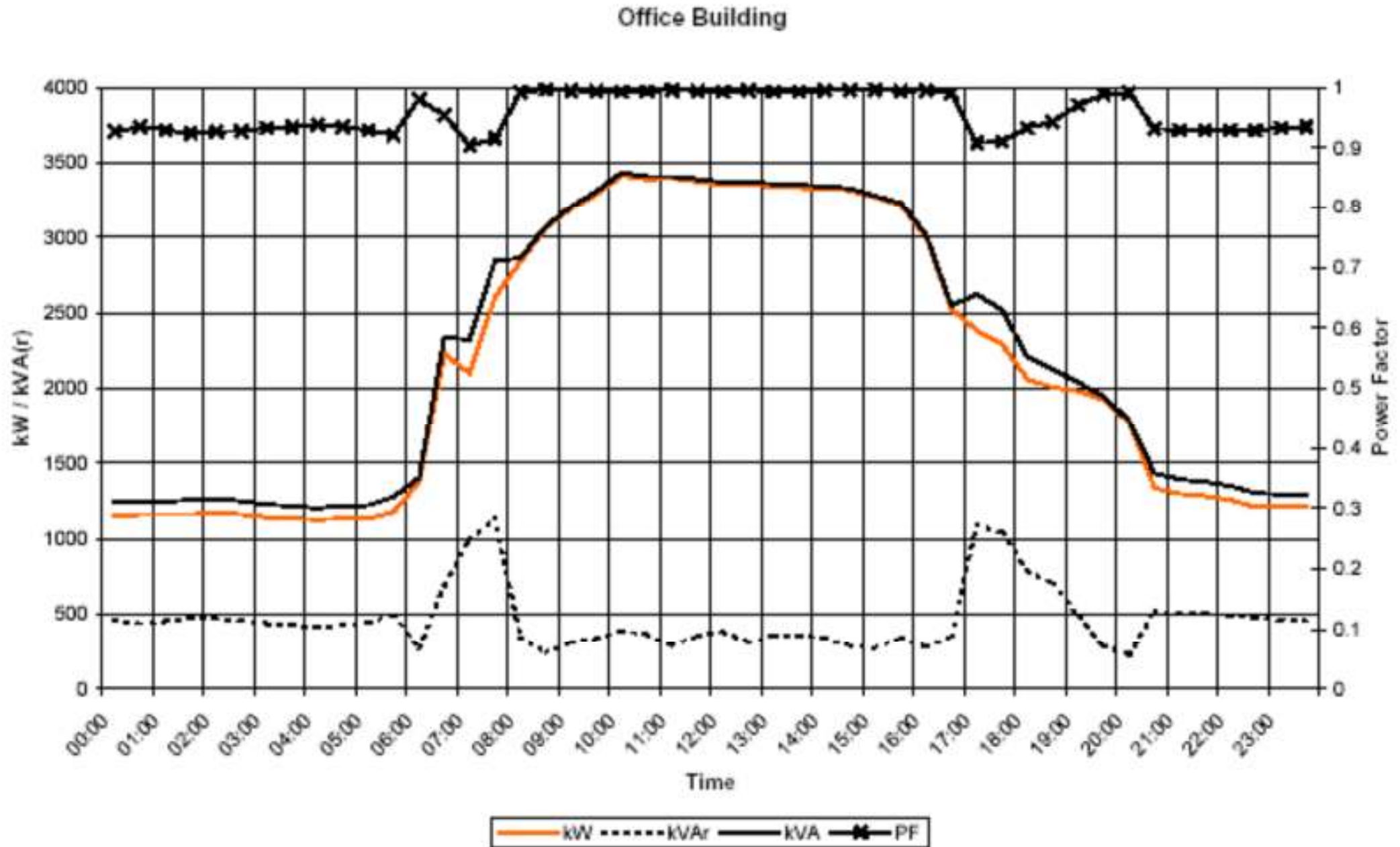

(Source: Department of Minerals and Energy, South Africa)

# Typical commercial building daily electric load profile

Could you interpret and explain this?

## Commercial Building Daily Electric Load Profile

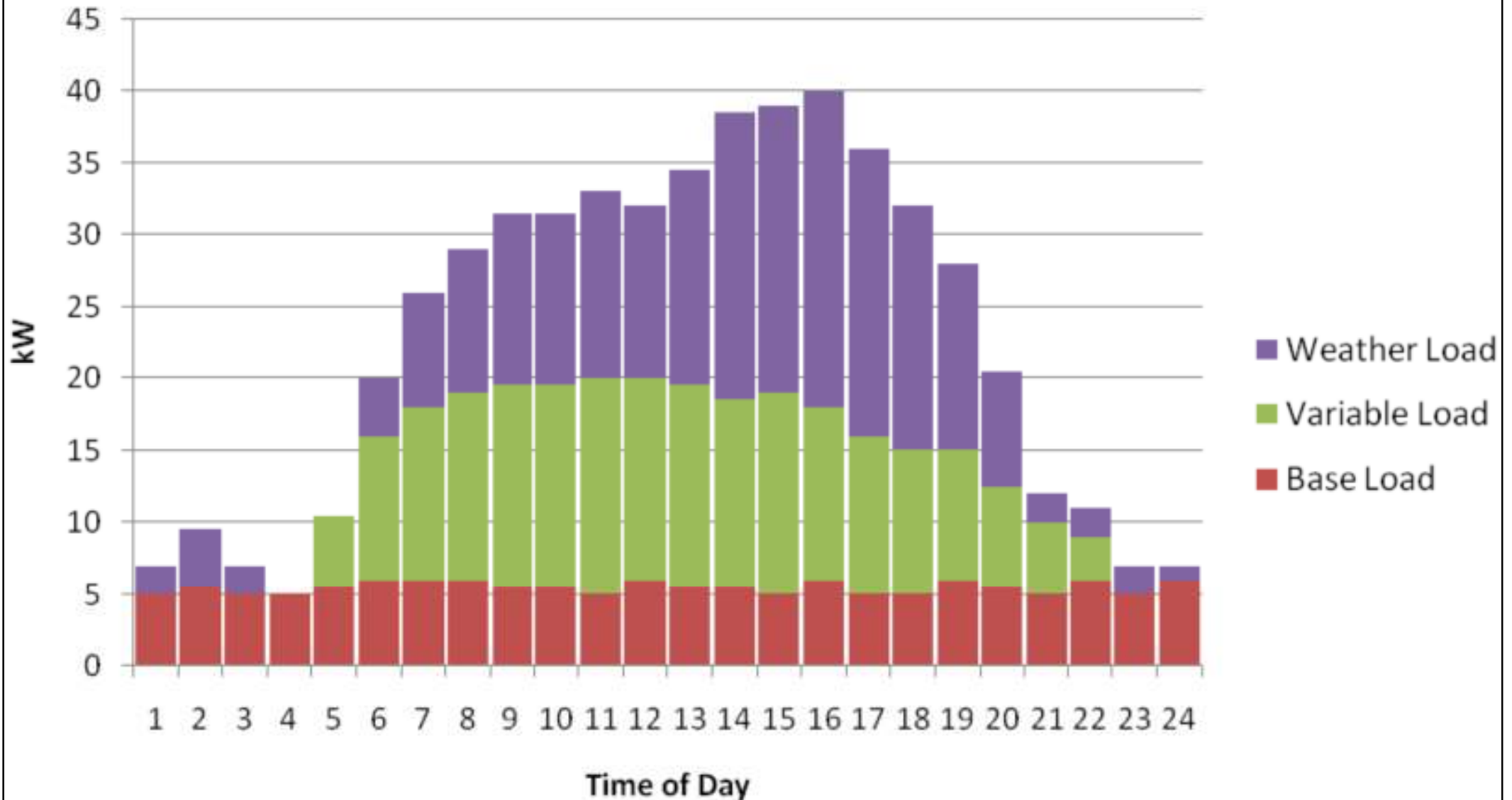



# Load Inventory

- Understanding where energy is used
  - Create an energy load inventory, and reconcile it to consumption data
- Analyse the load inventory
  - Where is electricity used?
  - How much - i.e. consumption
  - How fast - i.e. demand
- Why inventory? Focus your efforts; establish a basis for savings calculations

# Demand

**Plug Power**  
20.0%

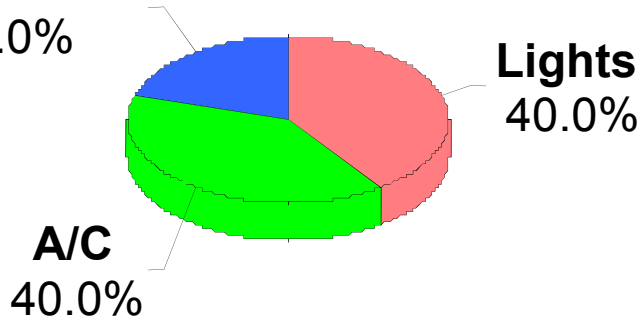

# Energy

**Plug Power**  
35.0%

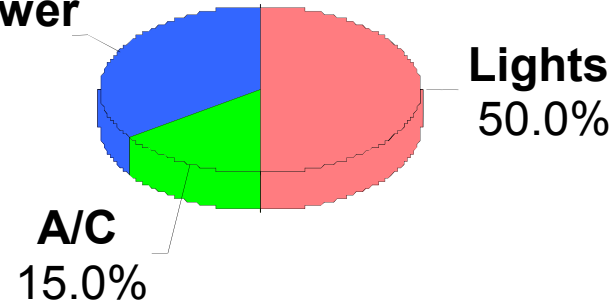

Item	Units	Formula
Quantity	(a number)	
Unit Load	kW	
Total kW	kW	Quantity. x Unit Load.
Hrs/Period	hours	
kWh/Period	kWh	Total kW x Hrs/Period
Diversity Factor (Div'ty Factor)	0 - 100%	
Peak kW	kW	kW x Diversity Factor

# Breakdown of demand, peak demand and energy

## Demand Breakdown

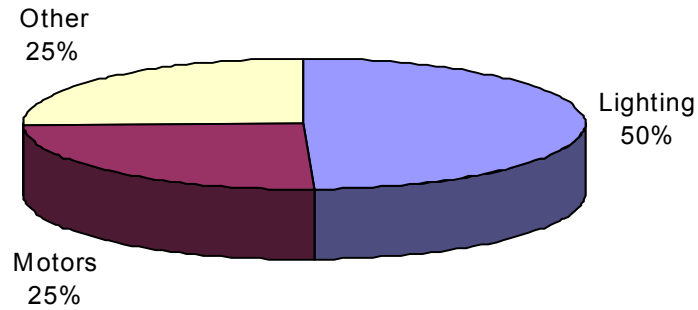

## Peak Demand Breakdown

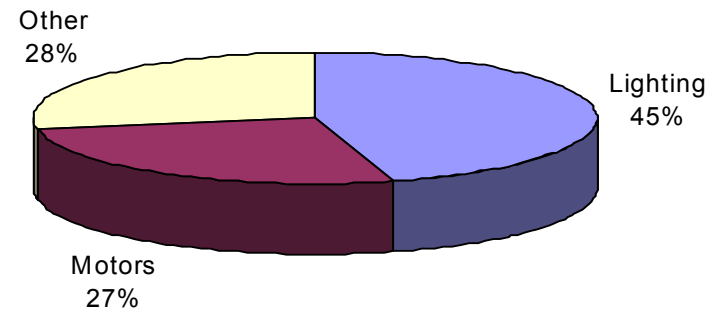

## Energy Breakdown

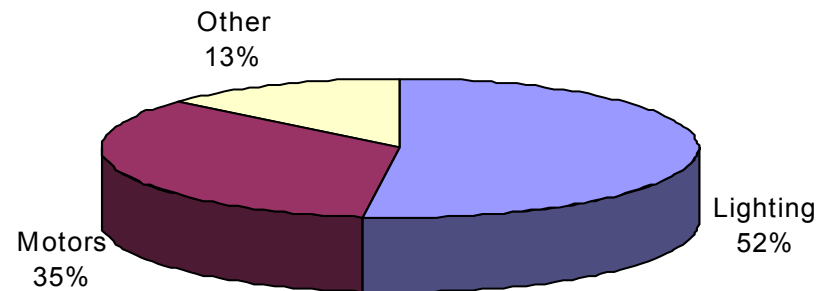



# Load Inventory

- An example of inventory:

Loads	Qty	Unit KW	Total KW	Diversity Factor	Peak KW	Hours	KWH
Fluorescent F96	4	0.165	0.66	1	0.7	300	198
Incandescent 100 w	24	0.1	2.4	0.9	2.2	100	240
400w MH Lights	21	0.465	9.765	1	9.8	420	4,101
Compressor.(60HP)	1	50	50	1	50.0	400	20,000
Pump (20 HP)	1	16	16	0.75	12.0	400	6,400
Micro-Wave	1	0.75	0.75	0.1	0.1	2	2
Coffee Machine	2	1.5	3	1	3.0	200	600
<b>Total</b>			<b>83</b>		<b>77.7</b>		<b>31,541</b>

# Energy flow diagram

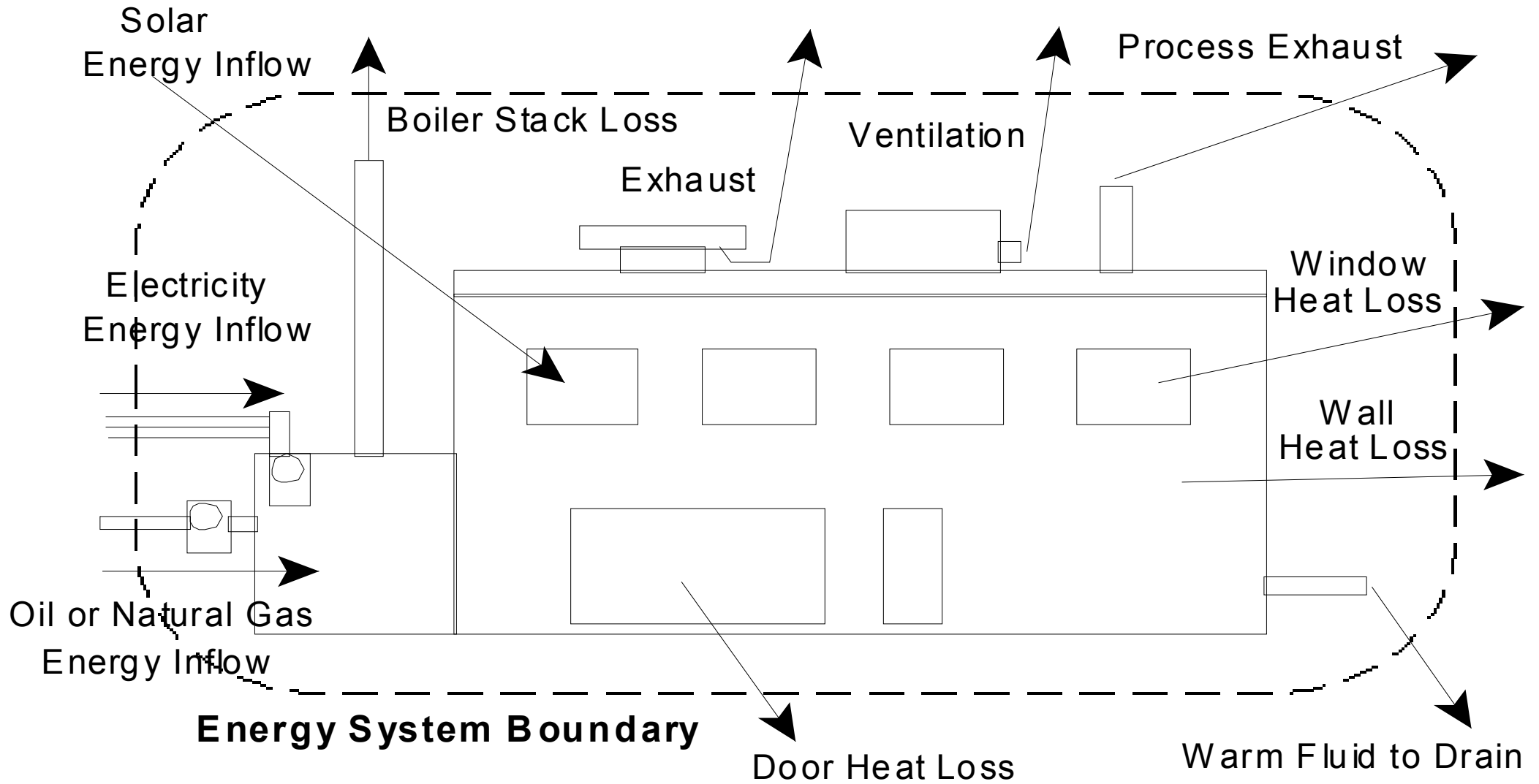

# Thermal energy inventory

<b>Energy Flow Type</b>	<b>Example</b>	<b>Equipment/Functions</b>
Conduction	Wall, windows	Building structure.
Air Flow - Sensible	General exhaust	Exhaust and makeup air systems, combustion air intake.
Air Flow - Latent	Dryer exhaust	Laundry exhaust, pool ventilation, process drying equipment exhaust.
Hot or Cold Fluid	Warm water to drain.	Domestic hot water, process hot water, process cooling water, water cooled air compressors.
Pipe Heat Loss	Steam pipeline.	Steam pipes, hot water pipes, any hot pipe.
Tank Heat Loss	Hot fluid tank.	Storage and holding tanks.
Refrigeration system output heat	Cold storage.	Coolers, freezers, process cooling, air conditioning.
Steam Leaks and Vents	Steam vent	Boiler plant, distribution system, steam appliance.



# Finding opportunities: Start at the end-use

**Meter**

**1<sup>st</sup> Analyze Present Usage**



**End-Use**

**2<sup>nd</sup> Identify and Quantify the Savings Opportunities**

**Component efficiencies:**

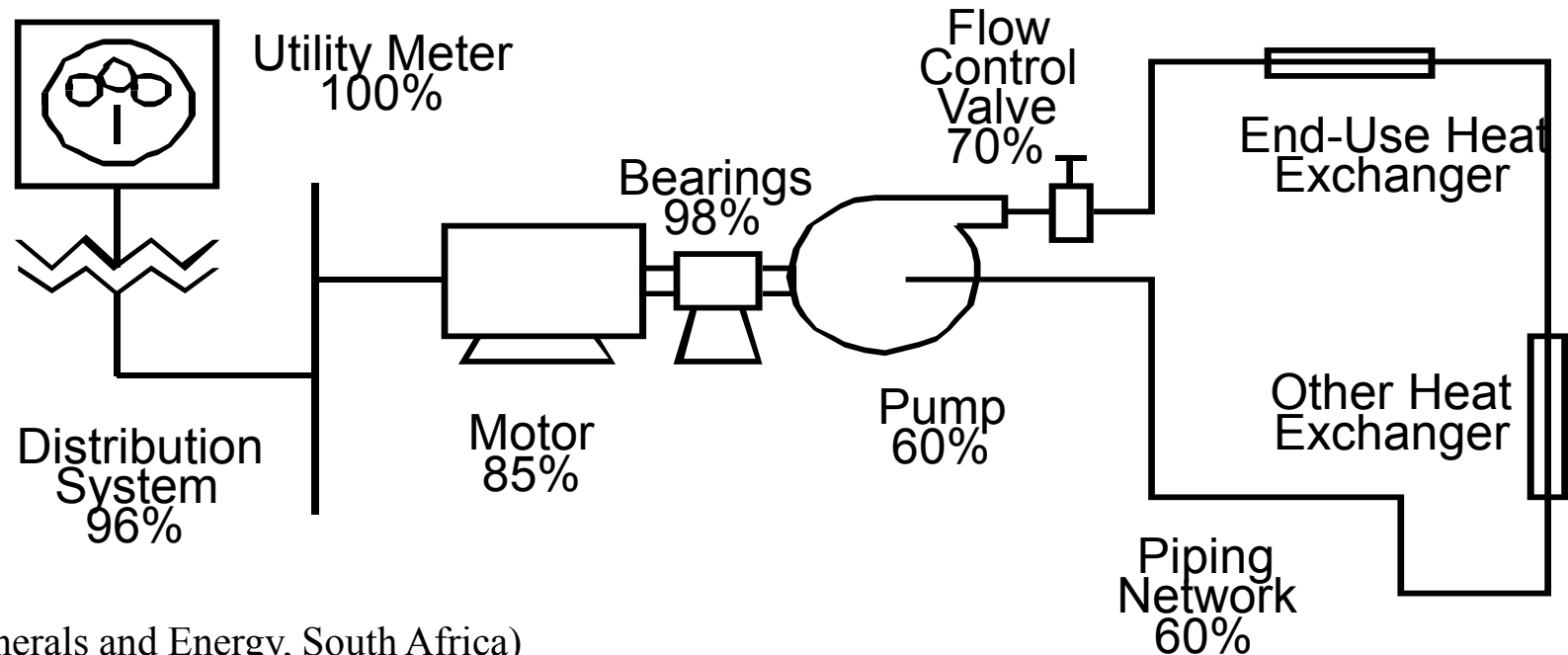

# Component and system efficiencies

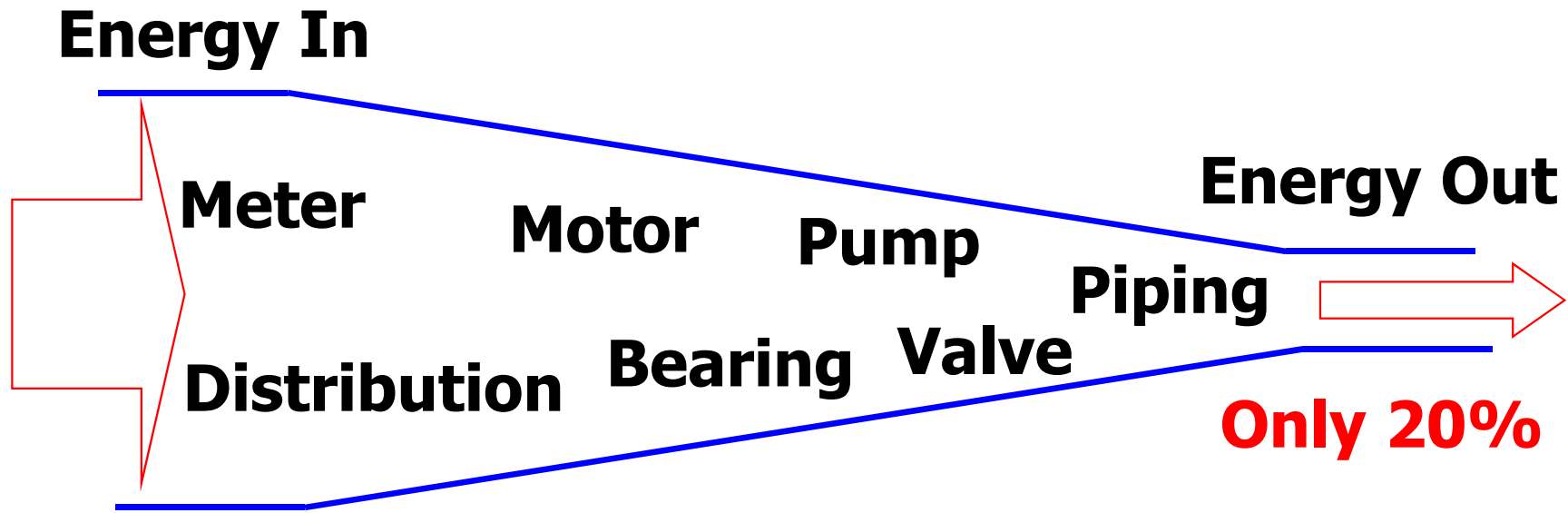

Component	Typical Efficiency
Meter	100%
Distribution	96%
Motor	85%
Bearing	98%
Pump	60%
Valve	70%
Piping	60%
Overall	20%