



Dynamic Building Performance Simulation



Dr. Sam C. M. Hui

Department of Mechanical Engineering

The University of Hong Kong

E-mail: cmhui@hku.hk

Contents

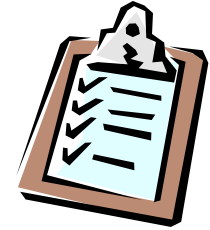

- Building Energy Simulation
- Simulation Tools
- Applying Simulation
- Modelling Process
- Simulation Skills



Building Energy Simulation

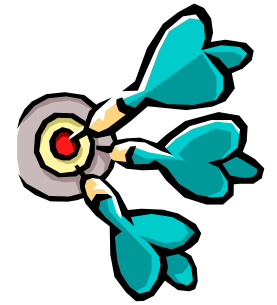

- Energy performance of buildings is usually complicated and requires detailed analysis to determine the characteristics
- Building energy simulation and modelling techniques are often used to study it so as to support decisions for building design, operation and management

Ways to study a system

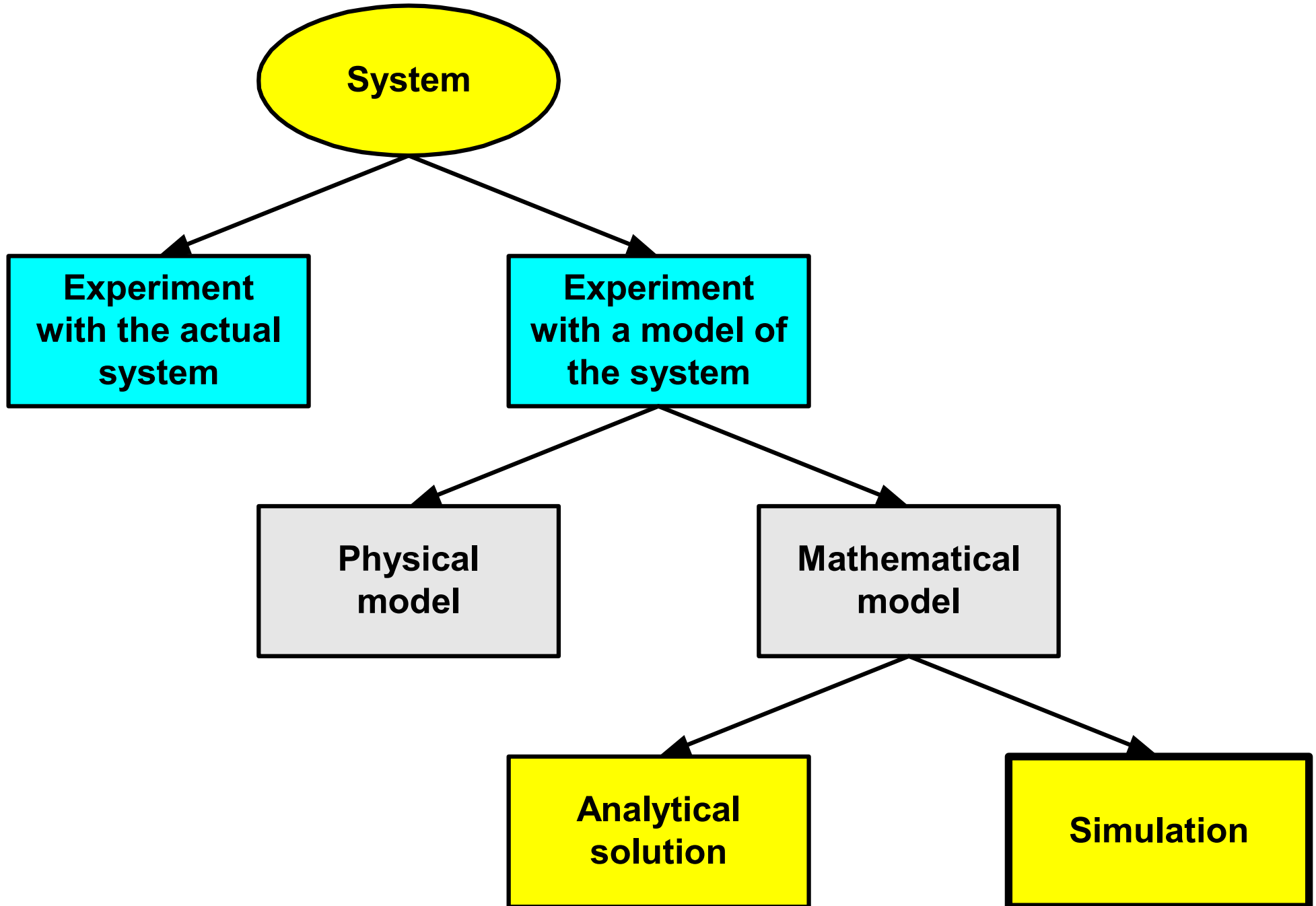

Building Energy Simulation



- Building performance simulation (BPS)
 - A computer model of the energy processes within a building that are integrated to provide a thermally comfortable environment for the occupants (or contents)
- Dynamic thermal simulation
 - Can predict changing internal conditions over a time period of up to **1 year – 8760 hours**
 - The technique predicts zonal (or room) values for parameters such as air temperature

Building Energy Simulation

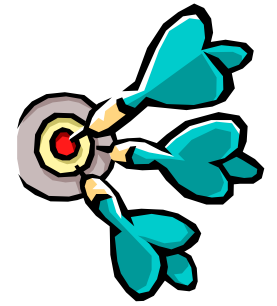

- What is Building Simulation?
 - Software which emulates the dynamic interaction of heat, light and mass (air and moisture) within the building
 - To predict its energy and environmental performance as it is exposed to climate, occupants and conditioning systems
- Building Simulation is needed if
 - Other methods are not feasible (e.g. physical model is too complicated or not economical)
 - You need to understand & analyse the building's performance in details

Building Energy Simulation

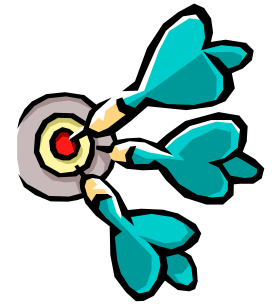

- Simulation

- The process of developing a representative model of a system and using it to analyze and predict system behaviour and performance

- Modelling

- Deals primarily with the relationship between actual dynamic processes and models
- Usually involves iterations

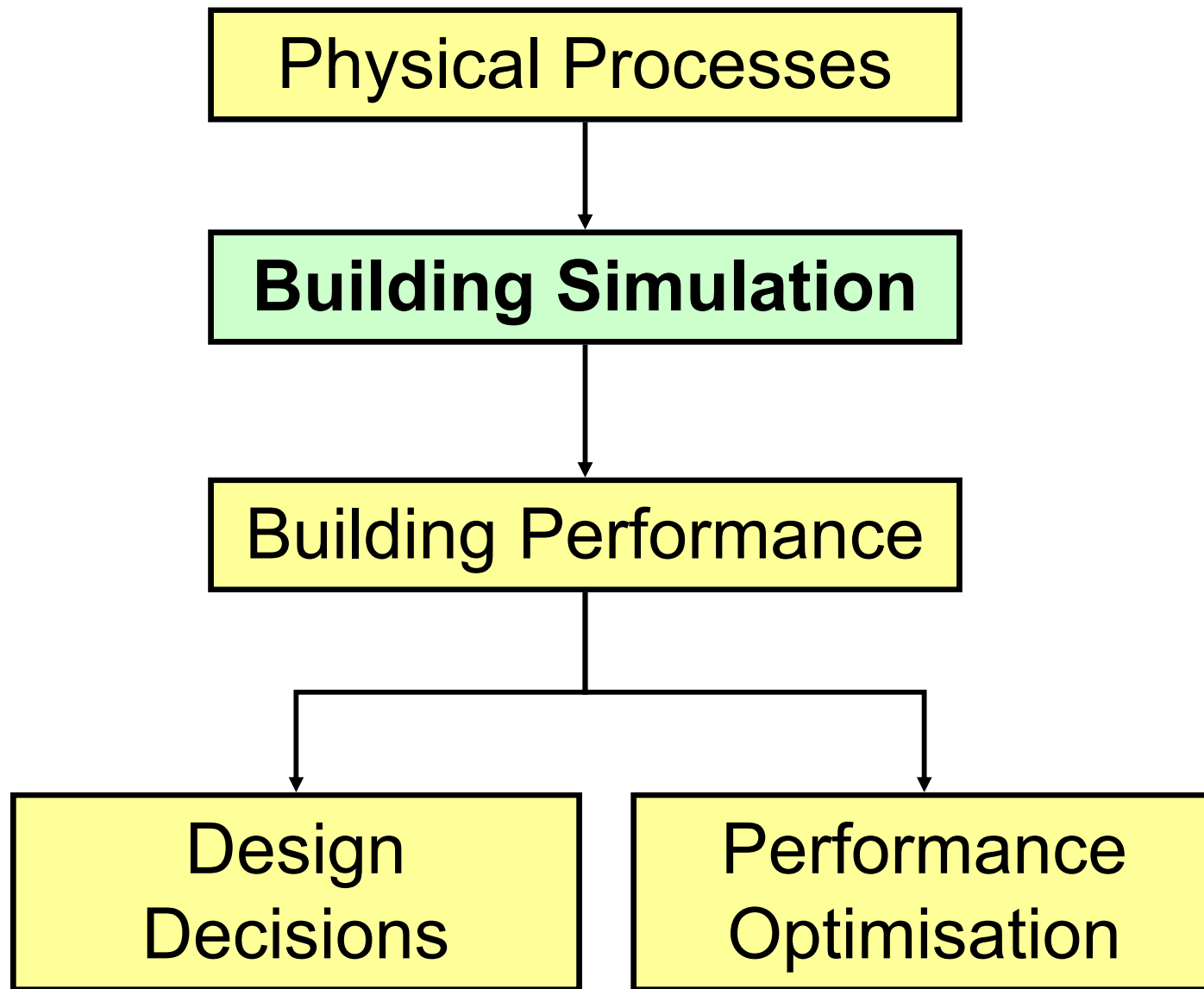

* Simulation enables the performance of the building to be established before critical design decisions are taken, enabling optimum building performance to be obtained

Components of building cooling load

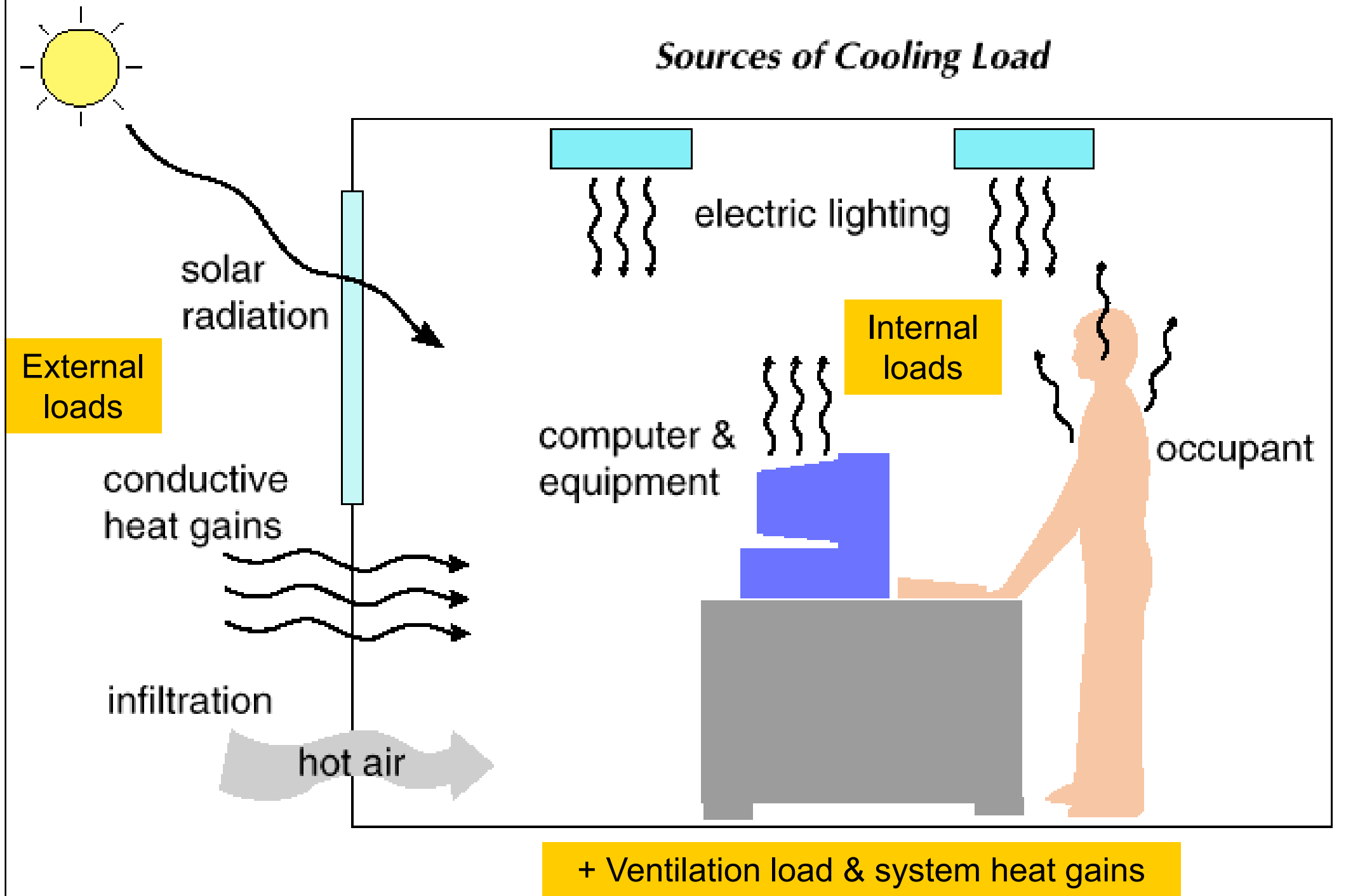

Building energy simulation process

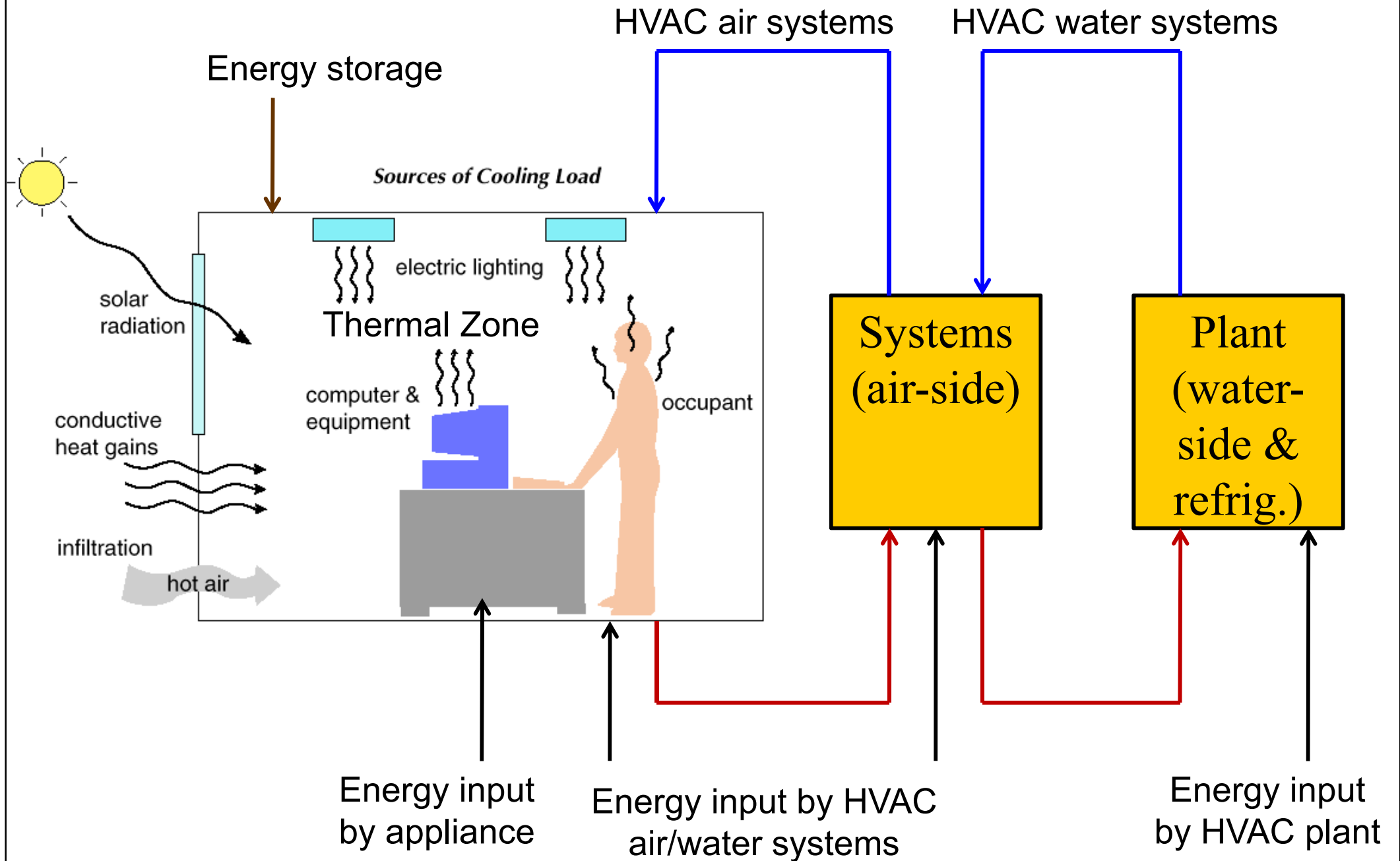

Building Energy Simulation

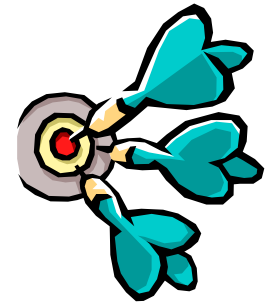

- Major functions of building energy simulation:
 - Assess building design ([design evaluation tool](#))
 - Calculate energy saving or performance ([building energy analysis tool](#))
 - Evaluate energy cost ([economic analysis tool](#))
 - Design & optimise building systems ([system design/optimization tool](#))
 - Satisfy energy code ([code compliance tool](#))
 - Support green building assessment ([green design tool](#))

Building Energy Simulation

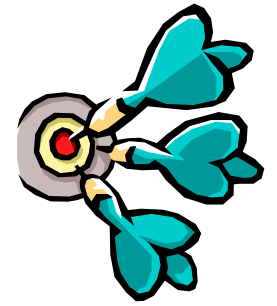

- Model existing buildings
 - Useful for “energy performance contracts”
 - Help improve the bldg’s operation/control
- Evaluate energy conservation measures (ECM)
 - Estimate energy savings
 - Study the costs and benefits
 - Provide info to design, retrofit & operation
- Comply with building energy code
 - Such as performance-based building energy code

Simulation Tools

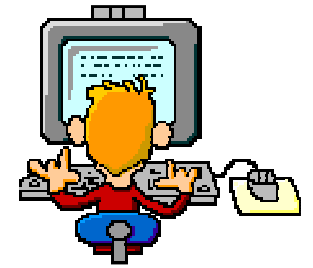

- Types of building simulation tools
 - Simplified software for overall energy consumption assessment, peak temperature prediction, cooling/heating load calculations
 - Sophisticated software for hourly simulation of heat, light & air movement
 - Complex specialist software, for lighting, computational fluid dynamics (CFD), 2- and 3-dimensional conduction calculations
 - Integrated design and analysis systems which combine a number of the above categories

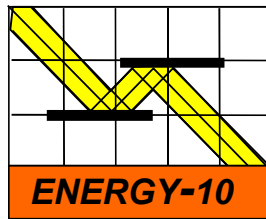

blast



DOE-2

Solar-5

ESP-r



ENER-WIN®

Hourly Energy Simulation Program for Buildings

**Building Energy
Simulation Software**



TRNSYS



E-20-II & HAP



TRANE®

TRACE 700



EE4

Simulation Tools

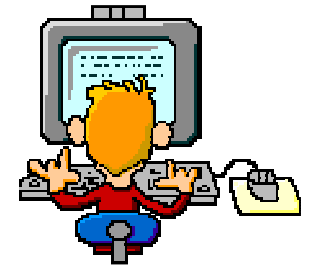

- Many software tools in the market
 - From simplified to complicated one
 - Select according to the task
- For beginners, we recommend
 - Energy-10, HAP, TRACE 700, eQUEST
- For sophisticated study, may consider
 - DOE-2, EnergyPlus, ESP-r, TRNSYS
- Further information:
 - Building Energy Software Tools Directory (by US-DOE)
 - http://www.eere.energy.gov/buildings/tools_directory/

Simulation Tools

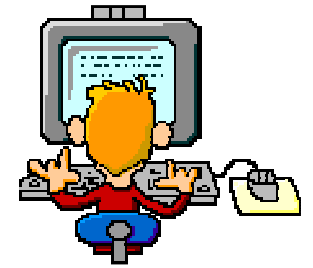

- Examples of building energy simulation tools
 - **Energy-10**
 - <http://www.sbicouncil.org/energy-10-software>
 - **VisualDOE** (based on DOE-2.1e)
 - <http://www.archenergy.com/products/visualdoe/>
 - <http://gundog.lbl.gov/dirsoft/d2whatis.html>
 - **MIT Design Advisor** (do online simulation)
 - <http://designadvisor.mit.edu/design/>

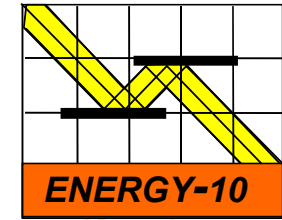

Example: Energy-10

ENERGY-10 focuses on the first phases (conceptual design)

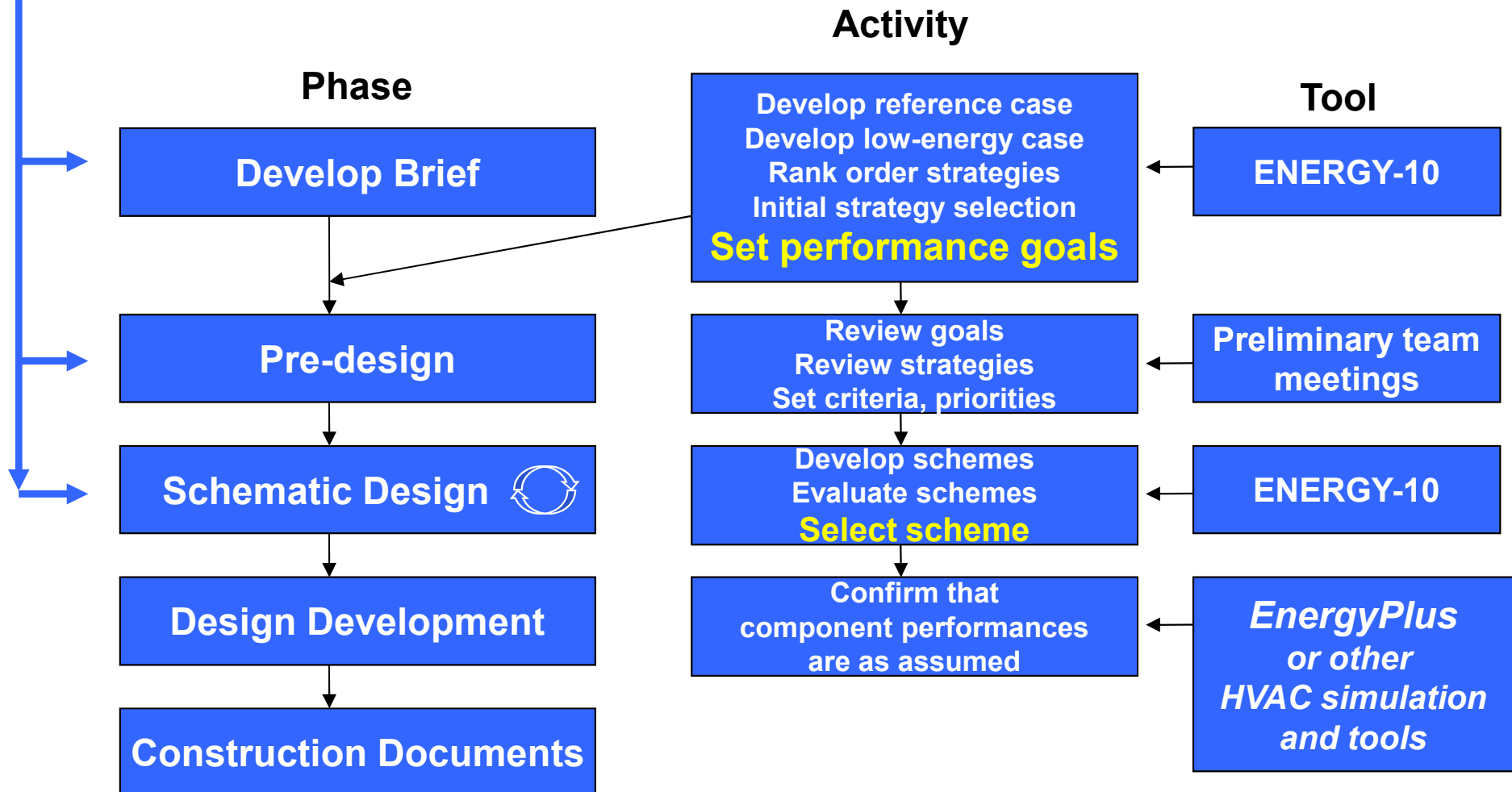

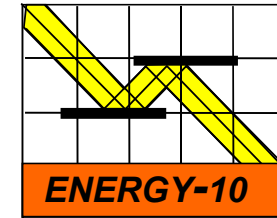

Example: Energy-10

- Creates two building descriptions based on five inputs and user-defined defaults.

- Location
- Building Use
- Floor area
- Number of stories
- HVAC system

For example:

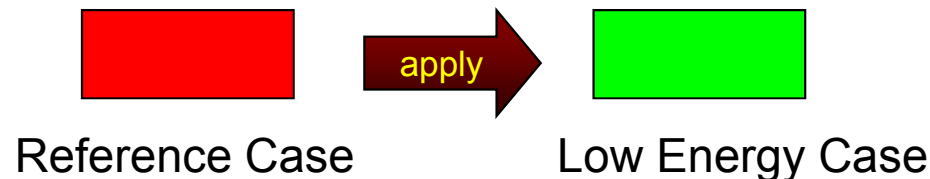

**Gets you
started
quickly.**

R-8.9 walls (4" steel stud)
R-19 roof
No perimeter insulation
Conventional double windows
Conventional lighting
Conventional HVAC
Conventional air-tightness
Uniform window orientation
Conventional HVAC controls
Conventional duct placement

R-19.6 Walls (6" steel stud with 2" foam)
R-38 roof
R-10 perimeter insulation
Best low-e double windows
Efficient lights with daylight dimming
High efficiency HVAC
Leakage reduced 75%
Passive solar orientation
Improved HVAC controls
Ducts located inside, tightened

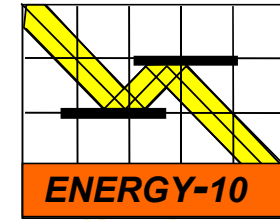

Example: Energy-10

2,000 m² office building

ANNUAL ENERGY USE

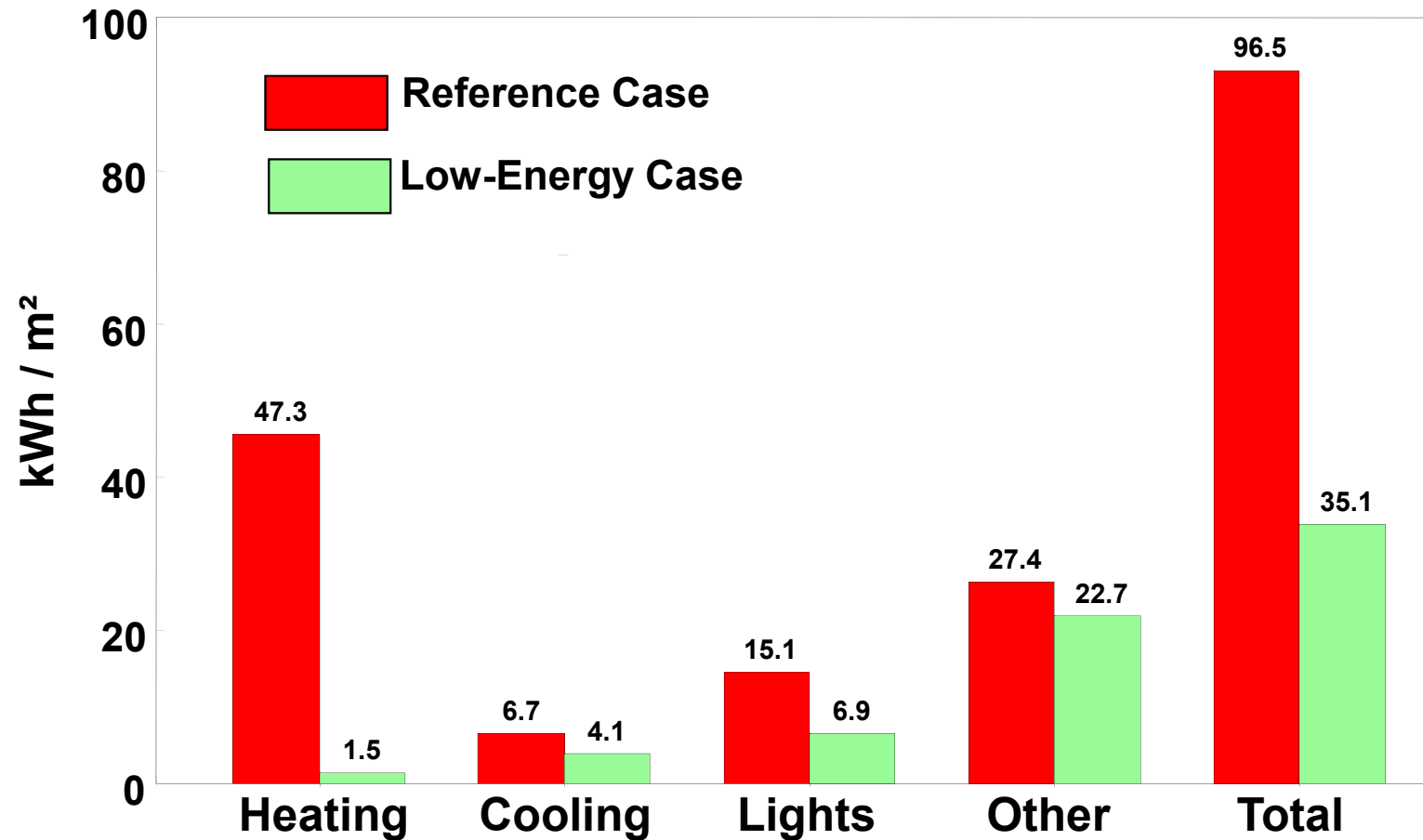

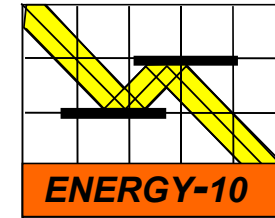

Example: Energy-10

RANKING OF ENERGY-EFFICIENT STRATEGIES

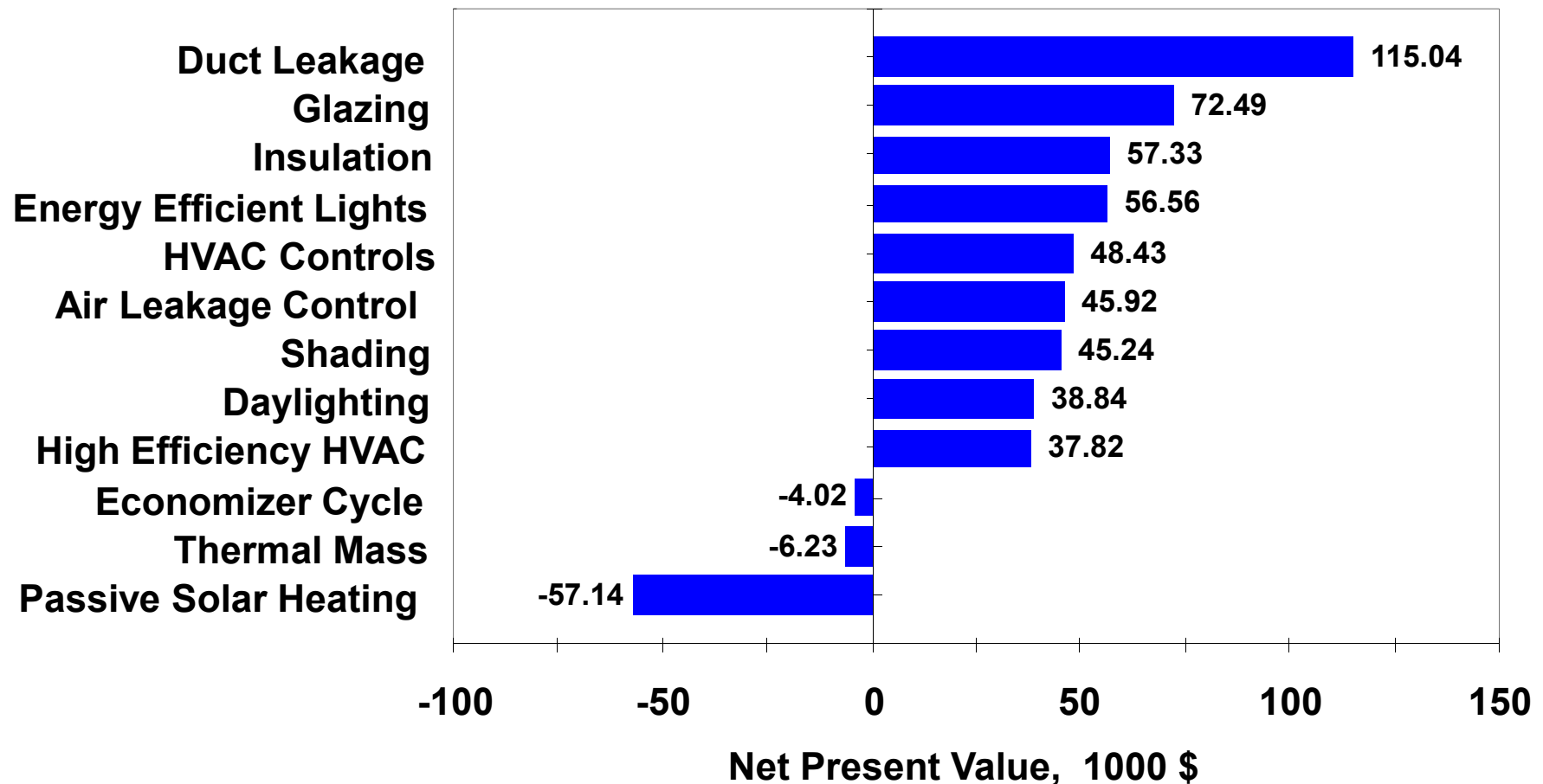

Example: Energy-10

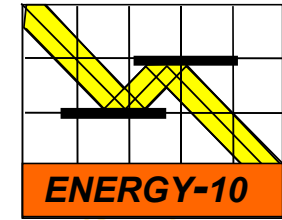

Sample - Lower-Energy Case

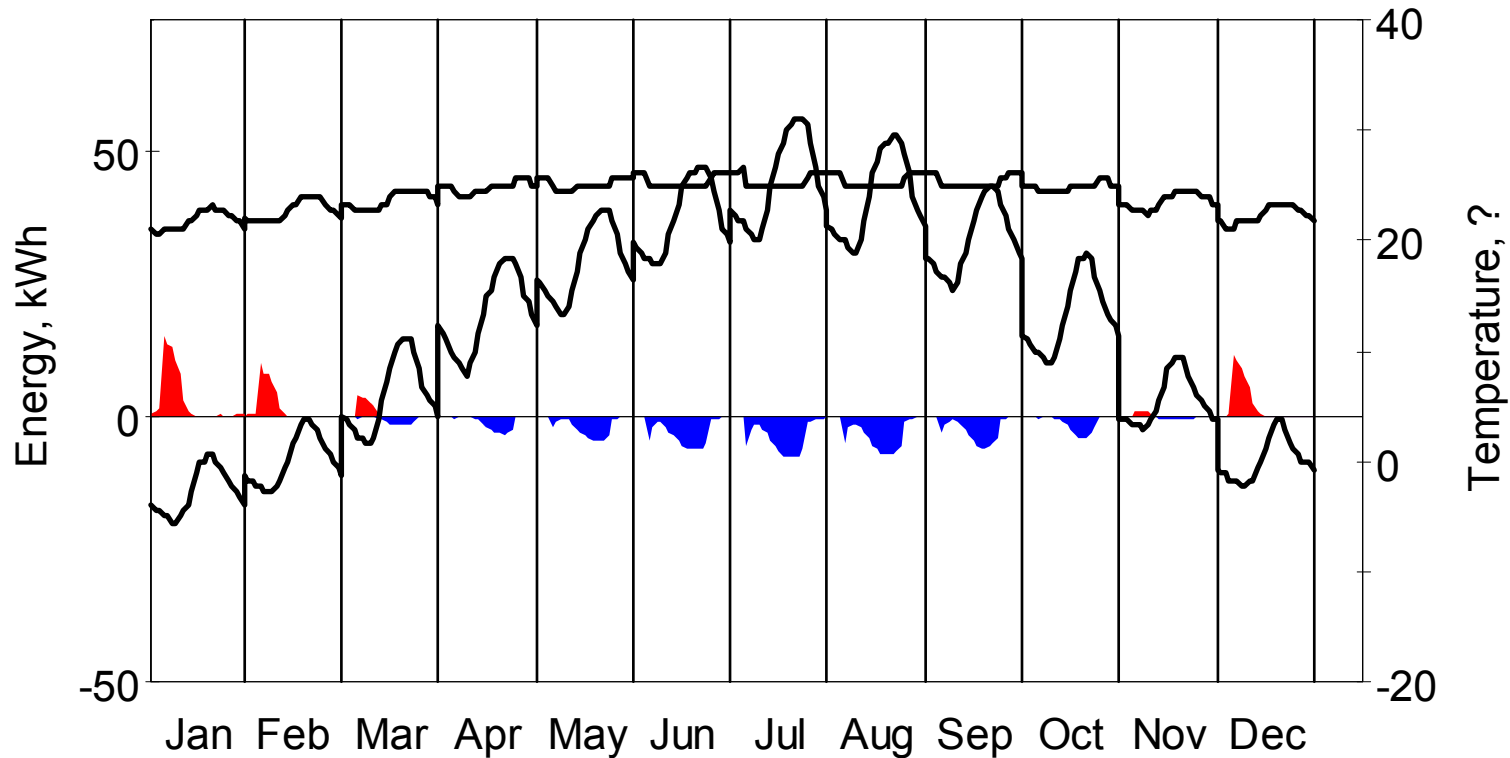

Average Hourly HVAC Energy Use by Month

Heating Cooling Inside T Outside T

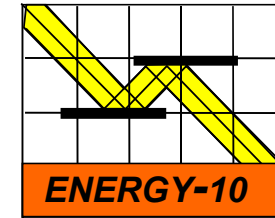

Example: Energy-10

Components of Life-Cycle Cost

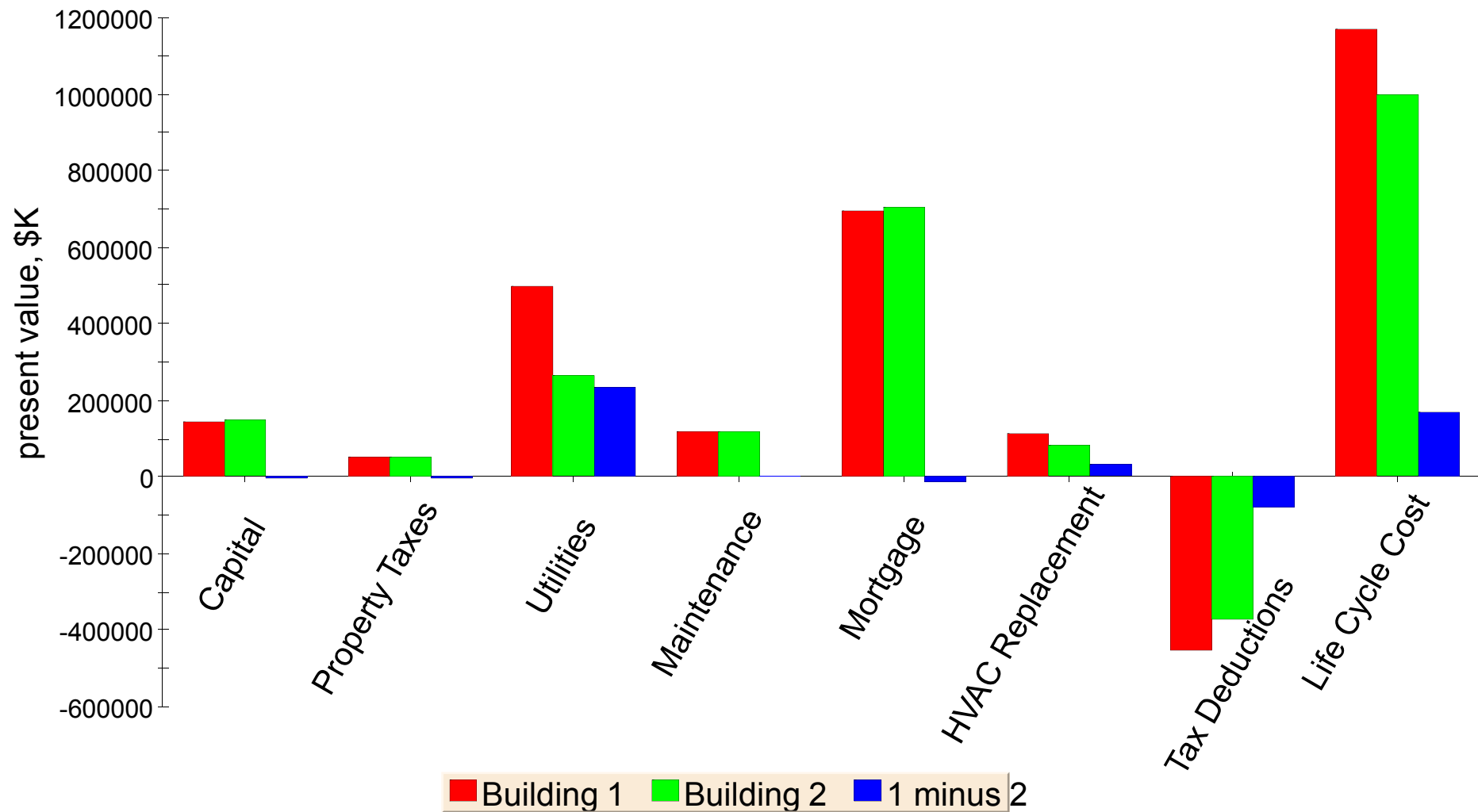

Example: VisualDOE

DOE-2

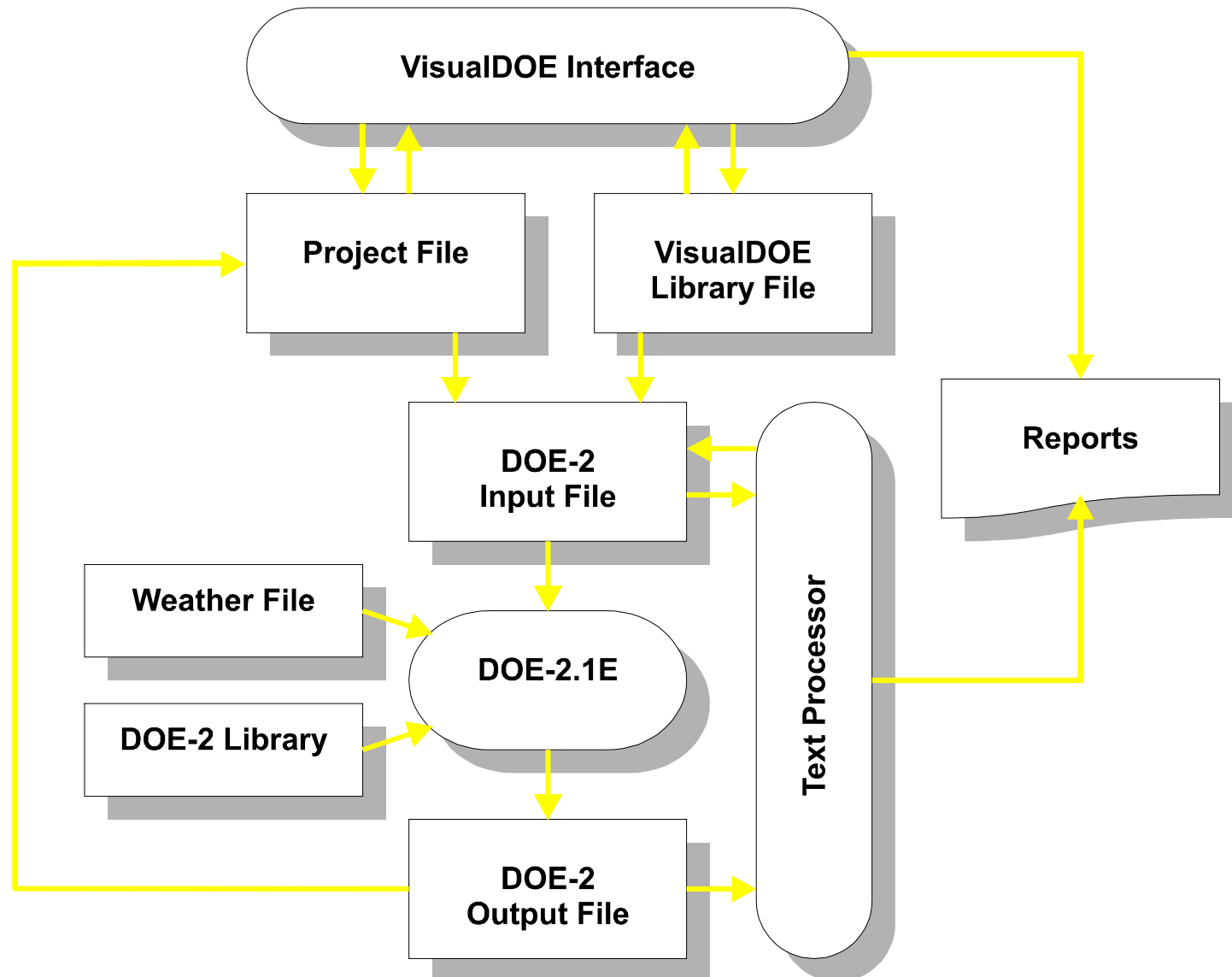

Example: VisualDOE

DOE-2

The screenshot shows the VisualDOE 4.0 software interface. The window title is "VisualDOE 4.0 - A sample building". The menu bar includes File, Edit, Alternatives, Simulation, Organizers, Tools, and Help. The interface is divided into several sections:

- Left Panel:** Contains a 2D floor plan of a building highlighted in yellow, a 3D perspective view of the building, and a north arrow. A "3D" button is visible.
- Project Settings Panel:** Includes tabs for Project, Blocks, Rooms, Facades, Systems, and Zones. The "Project" tab is active, showing fields for Project Name ("A sample building"), Energy Analyst ("engineer"), Address ("East Boston, Massachusetts"), and Description ("Energy modeling to support design optimization and LEED certification"). Other settings include Era Built (1989 to present), Climate Zone (Bostnma2), Holiday Set (Official US), Front Azimuth (115 degrees), Site Elevation (10 ft), Discount Rate (10%), and Project Life Cycle (20 years).
- Energy Resources Panel:** Shows settings for Electricity (1 meter) and Fuel (2 meters), with a utility rate of "NStar A5 TOU". A "Define Fuel Meters" button is present.
- Building Statistics:** A section titled "Building statistics (accurate after simulations are run. Area in ft²)" provides the following data:
 - Gross Floor Area: 133744
 - Conditioned Floor Area: 132085
 - Window Area: 10888
 - Skylight Area: 0
 - Window-Wall-Ratio: 21.4%
 - Skylight-Roof-Ratio: 0.0%
- Bottom Panel:** Includes buttons for "Refresh 3D Image" and "Show 3D View". The status bar at the bottom shows the file path "C:\Temp\MG Midrise A v35.gph", design name "Proposed Design", coordinates "X = -175 Y = 93", units "IP Units", and the date "9/18/03".

Example: VisualDOE

DOE-2

HVAC Systems Editor

Click on system equipment for specifications. Copy Sketch

System Features

- Preheat Coil
- Humidifier
- Return Fan
- Heat Recovery
- Evap. Precool
- Economizer
- Min. Outside Air
- Natural Ventilation

Min. OA Ratio:

System: MAU 1

Type: Single Zone Variable Temperature

Occupancy/Schedules: Corridor_ MG Med

System Era: 1989 to present

Return Air Path: Duct

Control Zone: 2_5_new_corr

Description:

Set As Default System Apply System Defaults Cancel OK

Example: VisualDOE

DOE-2

The screenshot shows the 'Central Plant Editor' software window. The title bar includes 'Central Plant Editor' and standard window controls. Below the title bar are buttons for 'Cancel', 'OK', and 'Copy Sketch'. The interface is divided into four tabs: 'General', 'Cooling Management', 'Heating Management', and 'Electrical Management'. The 'General' tab is active, displaying several configuration sections:

- Chilled Water Plant:** Chilled Water Temp.: 44 °F. Electric Chiller Types: None, 1, 2, 3, 4. # of Absorption Chiller Types: None, 1, 2, 3.
- Thermal Energy Storage
- Engine Driven Chiller
- Boilers:** Fuel Boiler Types: None, 1, 2. Electric Boiler Types: None, 1, 2.
- Electric Generators:** Diesel, Gas Turbine

The central schematic diagram illustrates a complex piping system. A red line represents a chilled water loop, starting from a tank at the top left, passing through a chiller unit, and connecting to an absorption chiller labeled 'Absorp. #1'. A blue line represents a heating loop, starting from a boiler unit, passing through a fuel boiler labeled 'Fuel #1', and connecting to a turbine generator. A green line represents an electrical distribution system, connecting the turbine generator to various electrical loads and control panels. The diagram also shows various pumps and valves. At the bottom of the window, a text prompt reads: 'Click on plant equipment for specifications.'

Example: VisualDOE

Print Preview

Export RTF Export PDF Close

3/4

VisualDOE 4.0 - Results September 18, 2003

Energy Cost Summary (\$/y)

Alternative	Total Electric	Total Fuel	Total Utility	Incremental First Cost	PV Life Cycle Cost*
Total Energy Costs (\$/y)					
ASHRAE 90.1 Budget Design Case	\$214,115	\$50,449	\$264,564	\$0	\$2,252,383
Proposed Design	\$203,404	\$78,084	\$281,488	\$0	\$2,396,466
Incremental Energy Savings (\$/y) <small>(compared with previous alternative, negative savings represent increases)</small>					
Proposed Design	\$10,711	\$-27,635	\$-16,924	\$0	\$-144,084

* 20 year life cycle w/ 10% discount rate.

Example: VisualDOE

DOE-2

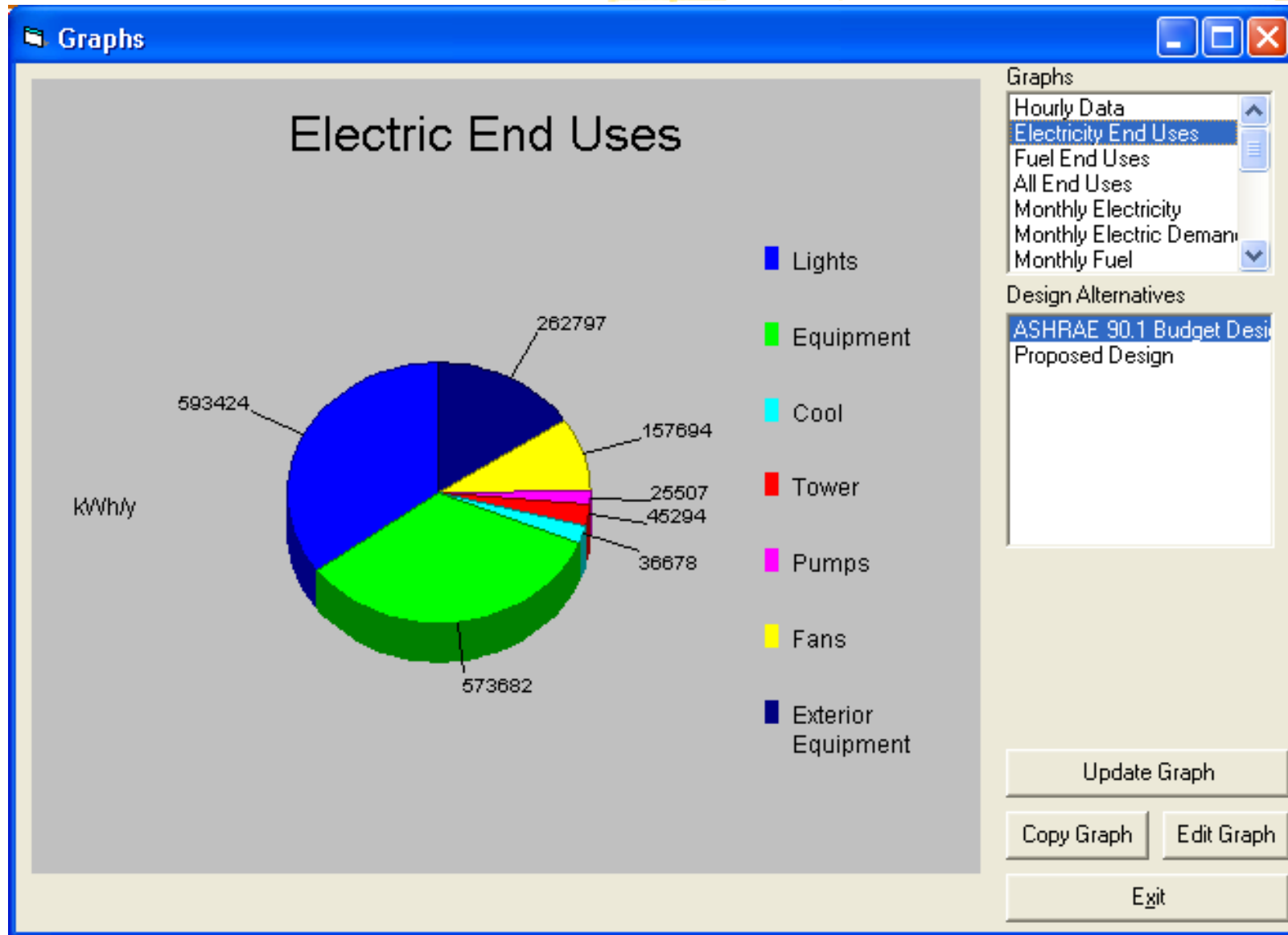

Example: VisualDOE

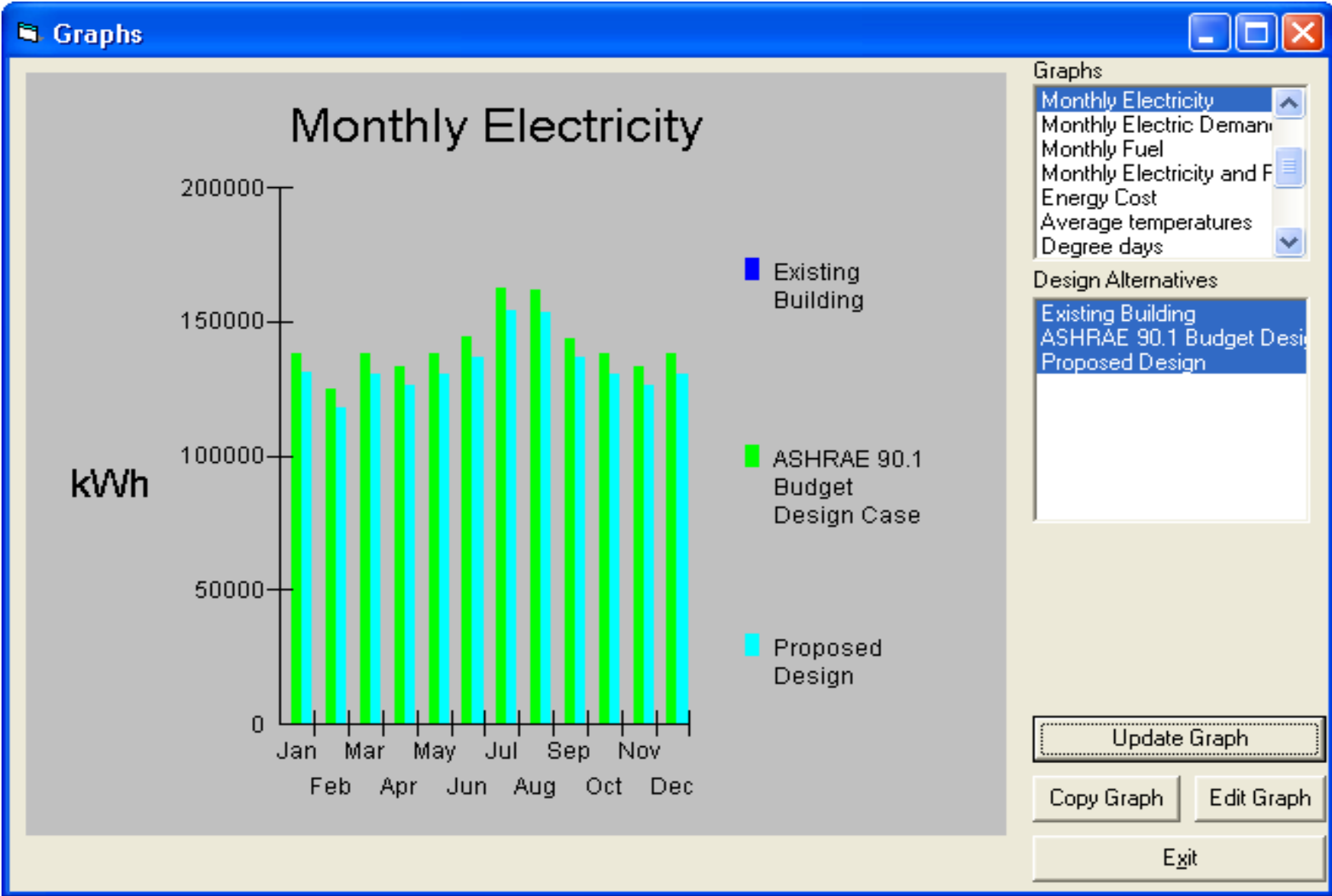

The MIT Design Advisor

Introduction

Setup

RESULTS:

Energy

Comfort

Natural
Ventilation

Daylighting:
Full Room

Daylighting:
Workplane

Life Cycle

Optimizer

Report

F.A.Q.

UPDATE - Changes have been made to the MIT Design Advisor!



Building energy simulation in minutes.

Heating, cooling, lighting, comfort, and more.

UPDATE - Version 1.1 now released

A new version of the MIT Design Advisor, Version 1.1, has recently been released (on 09/03/09) that includes the capability of adding different types of roofs to your building. Explore the new *Roof Description* section under the *Setup* tab to use the new feature, and the *Assumptions* page under the *F.A.Q.* tab for more information.

Overview

Architects and Building Designers can use computer modeling to improve indoor comfort and energy performance of conceptual building designs. But most simulation tools are too complicated for this purpose.

Quick, visual comparisons are needed for early-stage design. The MIT Design Advisor is a tool which allows you to describe and simulate a building in less than five minutes. No technical experience or training is needed. An annual energy simulation can be run in less than a minute, and graphical results are immediately available for review. Give it a try.

Getting Started

1. Begin by clicking the *SETUP* tab to the left and follow the directions to create a building design.
2. To save and simulate your building scenario, click *Save* on one of the colored scenario boxes at the bottom panel.
3. View the simulation results by clicking on any of the tabs to the left (Comfort, Energy, etc.)

Look for the information buttons for extra help:



About Us

MIT Building Technology Program
MIT Department of Architecture

SAVE

Scenario
One

SAVE

Scenario
Two

SAVE

Scenario
Three

SAVE

Scenario
Four

Modelling Process

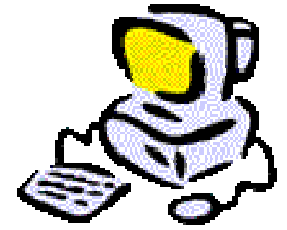

- How to perform building simulation?
 - Select and master how to use a program
 - Represent the building and HVAC systems
 - Construct the simulation model
 - Develop the building description
 - Prepare the input data
 - Run and control the program
 - Interpret the results, analysis and reporting
 - e.g. determine energy and cost savings

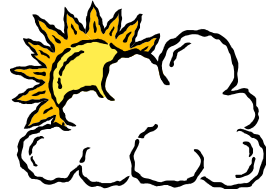

Weather
data

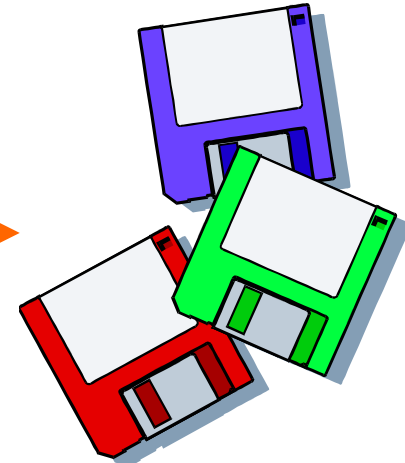
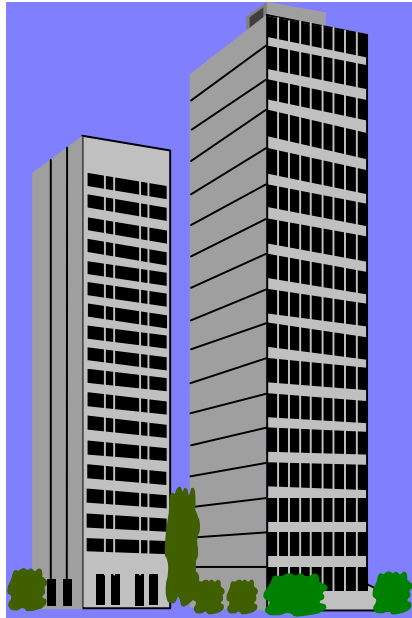

Building description

- physical data
- design parameters

Simulation tool (computer program)

Simulation outputs

- energy consumption (MWh)
- energy demands (kW)
- environmental conditions

Building energy simulation: Inputs and Outputs

INPUTS:

- Weather data
- Building geometry
- Construction type
- HVAC type / usage
- Occupancy info
 - Quantity of users
 - Lights
 - Equipment
 - Usage

OUTPUTS:

- Space temperatures
- Surface temperatures
- Humidity levels
- HVAC parameters
- Energy consumption
 - Component
 - System
 - Whole-building

Garbage In, Garbage Out (GIGO)



Modelling Process

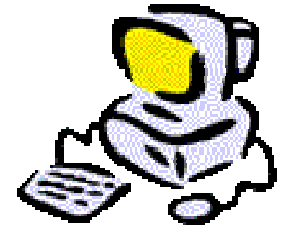

- Important considerations
 - *Start early*: incorporate building simulation into the early design stages
 - *Keep it simple*: add no more detail to a simulation model than is necessary (simple but accurate)
 - *Refine as you go*, so that the simulation model evolves with the design
 - *Avoid mistakes* and reduce the potential for error

Modelling Process

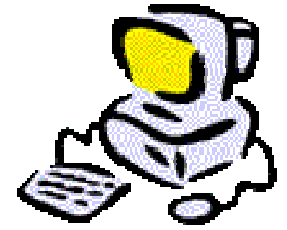

- Important to know how the program “thinks” about systems and designs and interactions
- How to approximate real-world problem to fit the limitations of the model

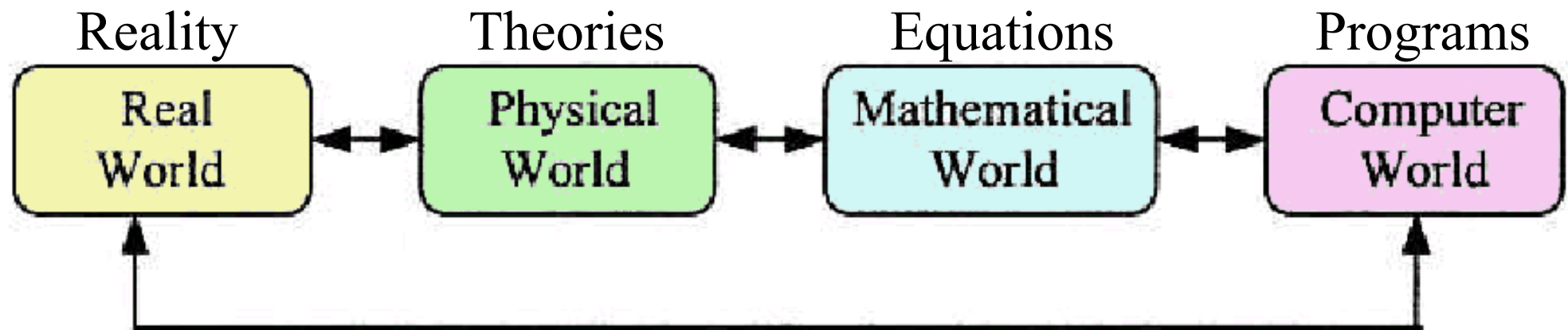

Modelling Process

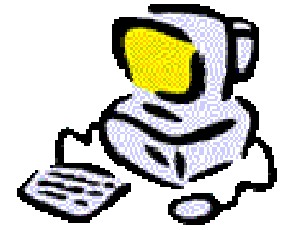

- Building energy simulation is based upon
 - *Load calculation* – thermal or HVAC
 - Determine peak HVAC design loads
 - *Energy calculation* – energy to meet the loads
 - Estimate annual energy requirements
- Time intervals
 - Full hour-by-hour (**8,760 hours** = 365 x 24)
 - Simplified hourly: e.g. one day per month
 - Bin method or degree days

Modelling Process

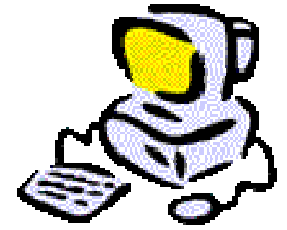

- Four major elements
 - Building model
 - HVAC system model
 - HVAC plant model
 - Control system model
- An economic model (optional) may be added for economic analysis and life cycle costing

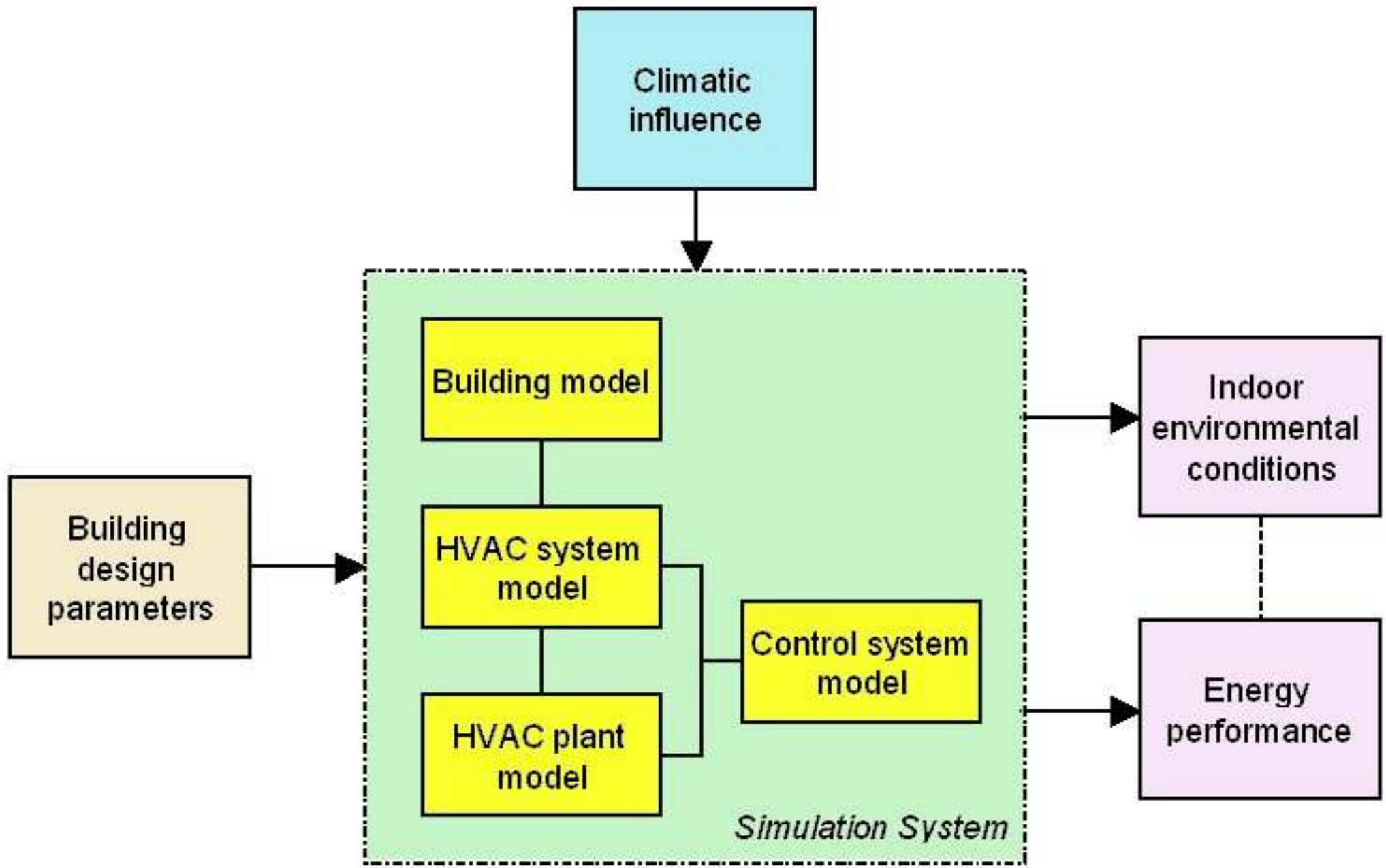

Major elements of building energy simulation

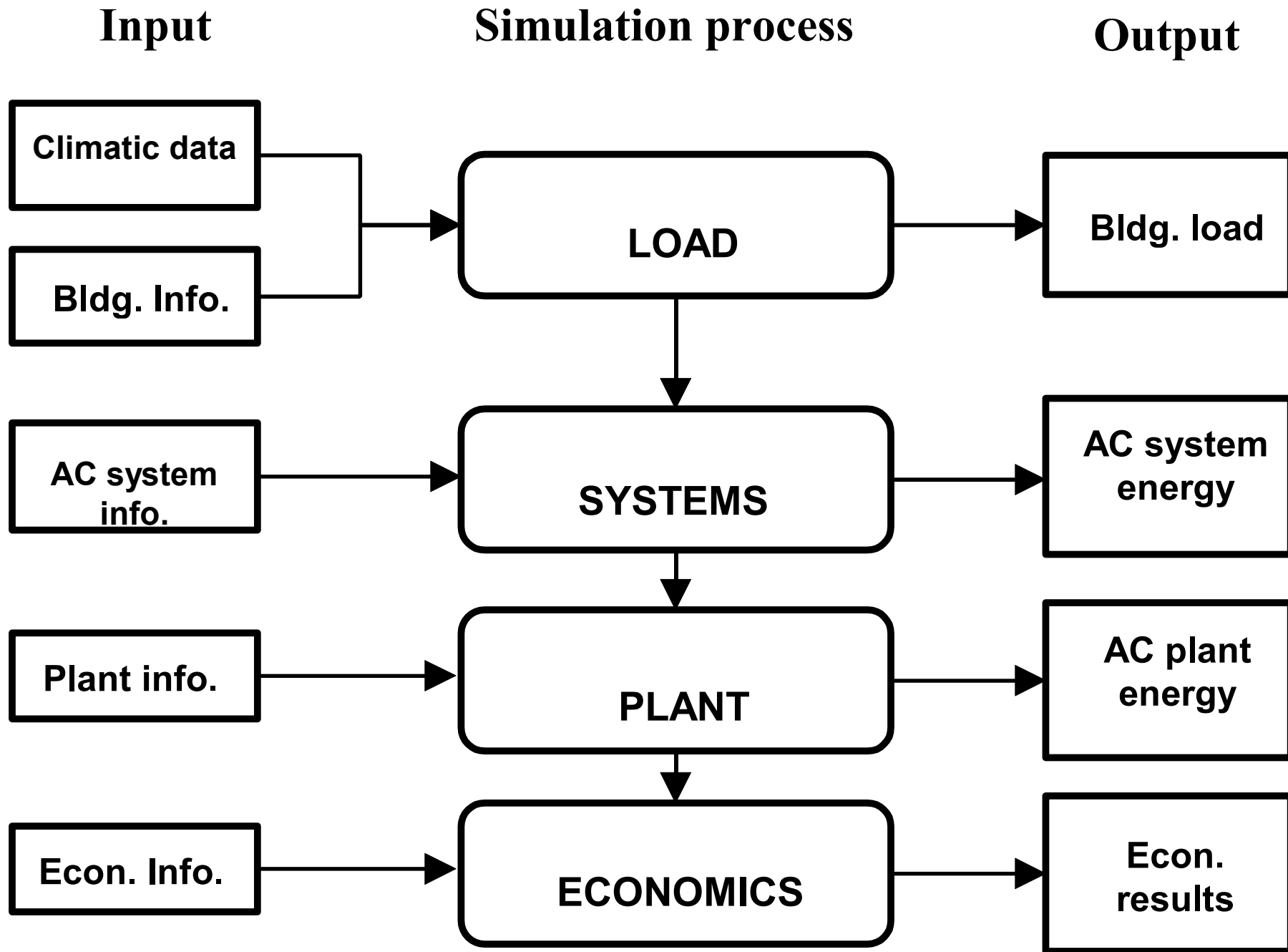

Information flow in building simulation

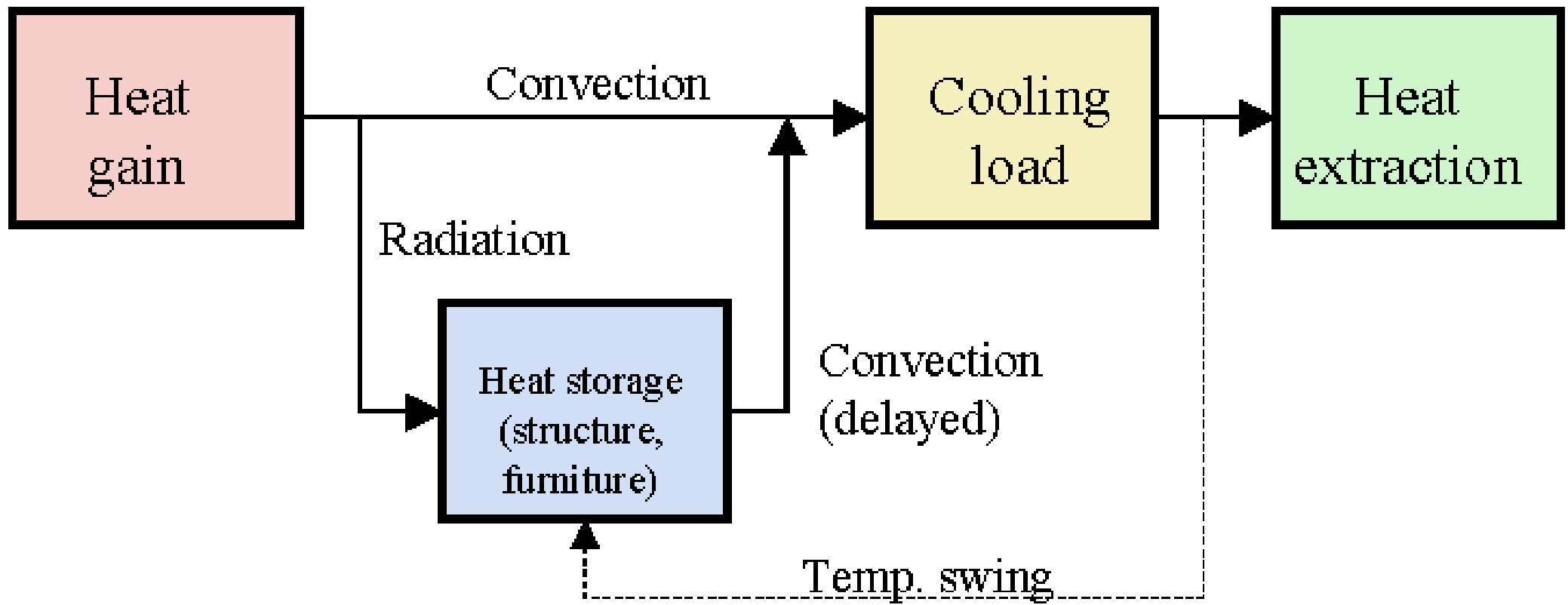

Concept of heat transmission and conversion in buildings

“Seven
steps”
of
simulation
output

LOADS

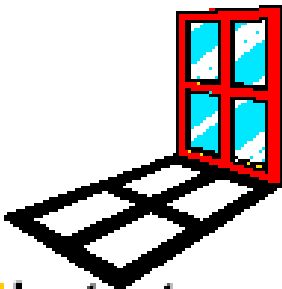

1

Instantaneous
Gain

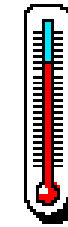
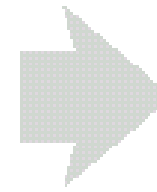

2

Space
Load

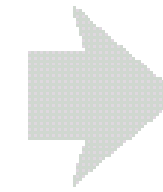

SYSTEMS

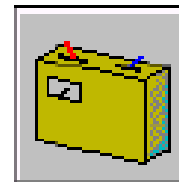

3

Heat
Extraction

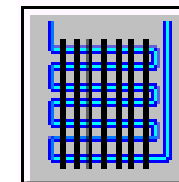
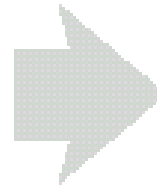

4

Coil
Load

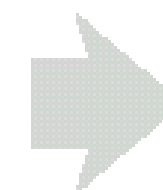

PLANT

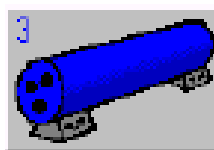

5

Primary
Energy/Demand

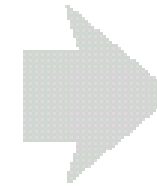

ECONOMICS

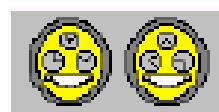

6

Utility
Rate

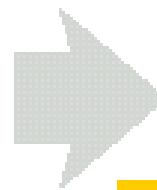

7

Utility
Costs



Simulation Skills

- Model zoning (*thermal*, not geometric)
 - Consider thermal loads (e.g. interior-perimeter), occupancy, lighting type and schedule
 - For existing buildings, refer to actual zoning
 - Need to *simplify* the model
 - Combine zones with similar load and usage
 - Intermediate typical floors treated as one floor
 - Combine HVAC systems
 - Sometimes, use ONE zone to quickly calculate the total load first

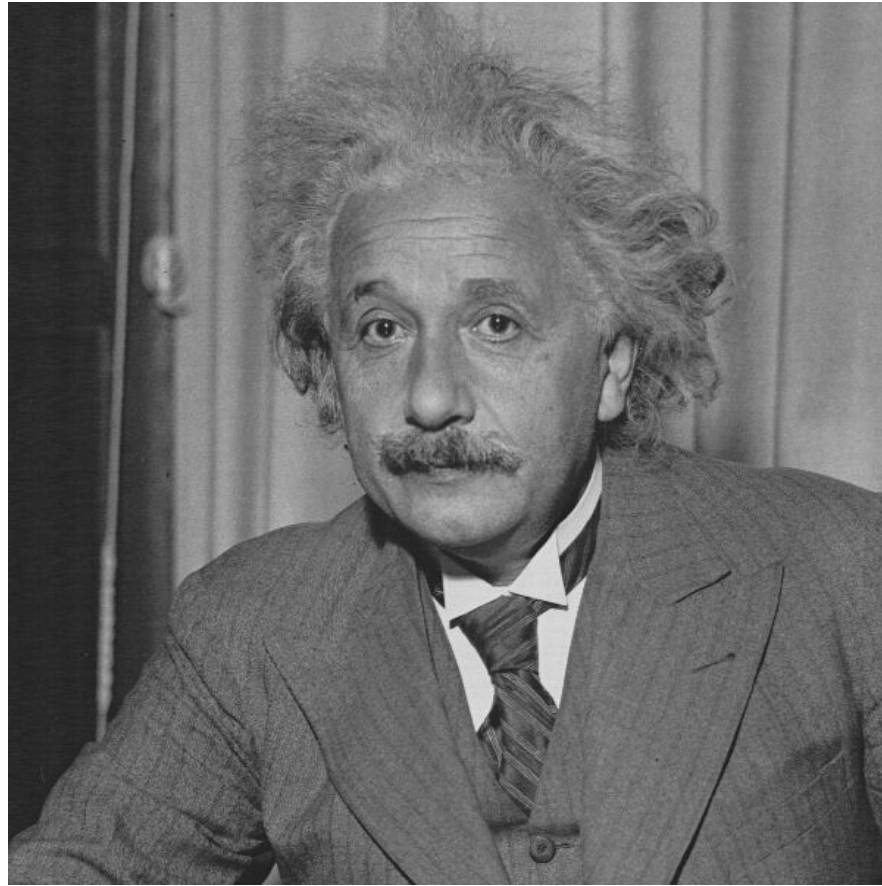

Make things as simple as possible,
and no simpler. (Albert Einstein)

Combine several rooms into one zone

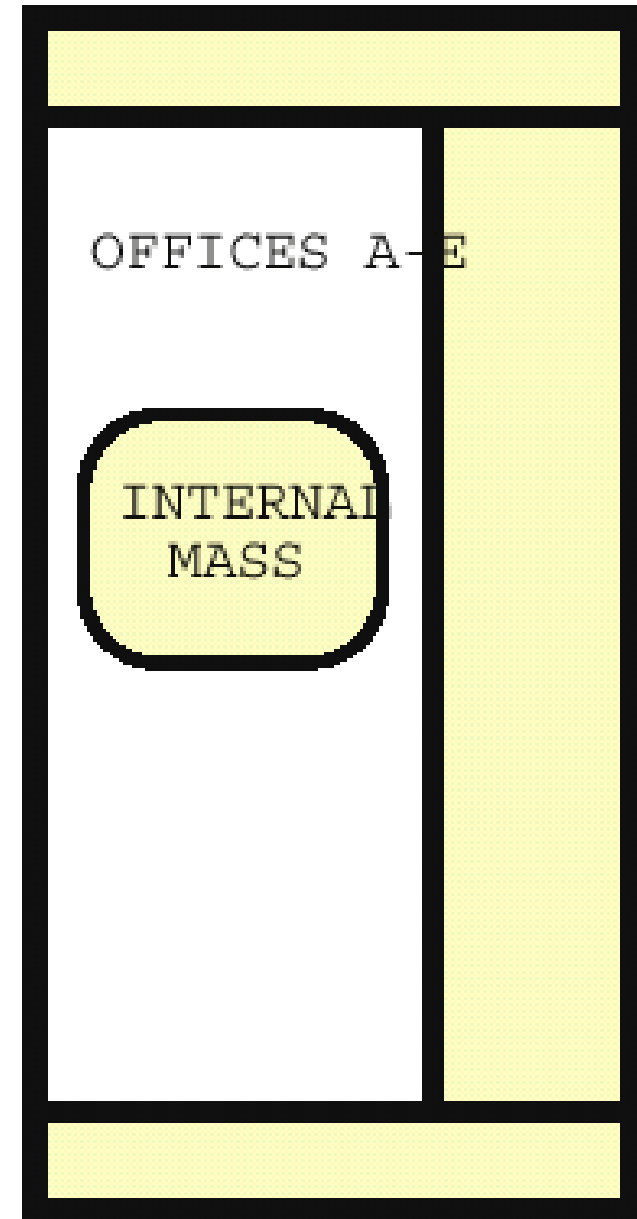
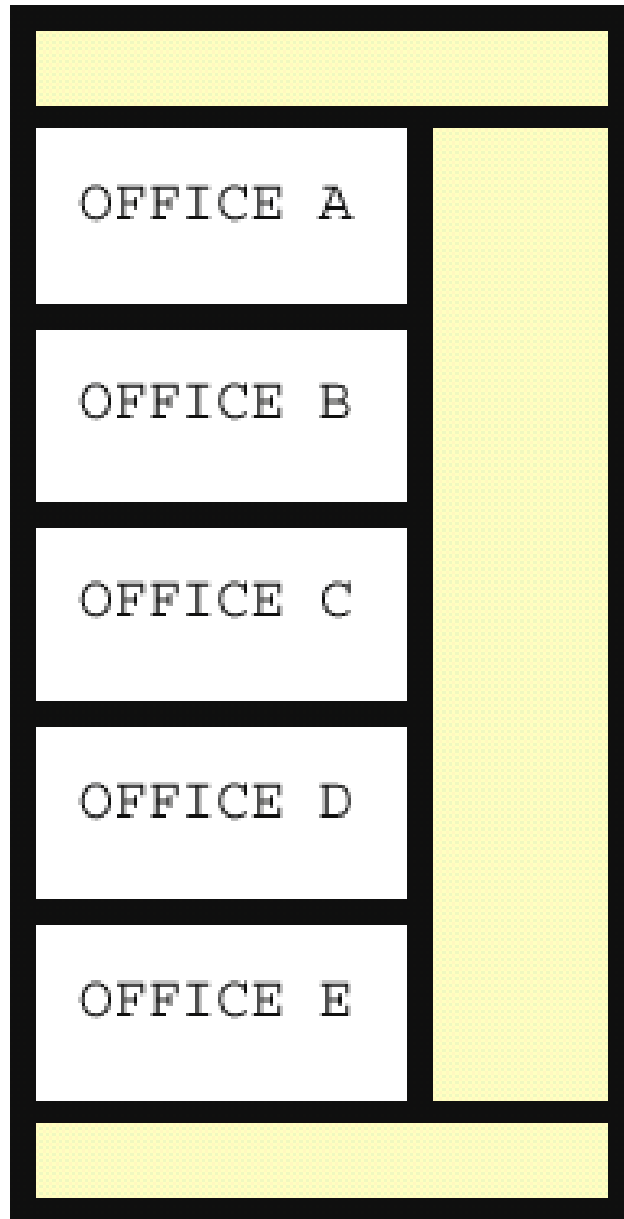



Simulation Skills

- General rules for zoning
 - One exterior zone per major orientation (4 to 5 m deep)
 - One internal zone per use schedule
 - One plenum zone (if plenum returns) for each air handler
 - One zone each for special uses
 - Separate ground and top floor zones



Simulation Skills

- Overall building characteristics
 - Simple building driven by external loads
 - Complex building driven by internal loads
- Types of loads
 - Weather-related loads
 - Time-related loads
- HVAC characteristics and controls
 - Is dynamic response of the system critical?



Simulation Skills

- Focus on inputs of significant impact
 - Small buildings – heat loss to ground and roof, through unconditioned spaces
 - Large buildings – zoning, controls, HVAC system types, internal loads
 - Retrofit projects – actual operating conditions, occupant behaviours, controls
- Judged by experience, sensitivity analysis, or real measurements/data



Simulation Skills

- For existing buildings
 - Study the as-built drawings and existing features
 - Collect historical data and logs
 - Take appropriate measurements
 - Observe building occupancy
- May coordinate energy audit and simulation to calibrate or tune the simulation model



Simulation Skills

- Typical simulation results and output
 - Thermal loads (of building, zones, components):
by hour, day, month or year
 - Temperatures (air, surfaces)
 - Fuel and energy uses
 - Consumption (month, year)
 - Peak demand (month, year)
 - System components
 - Output formats
 - Tabular, graphic, export to other analysis tools

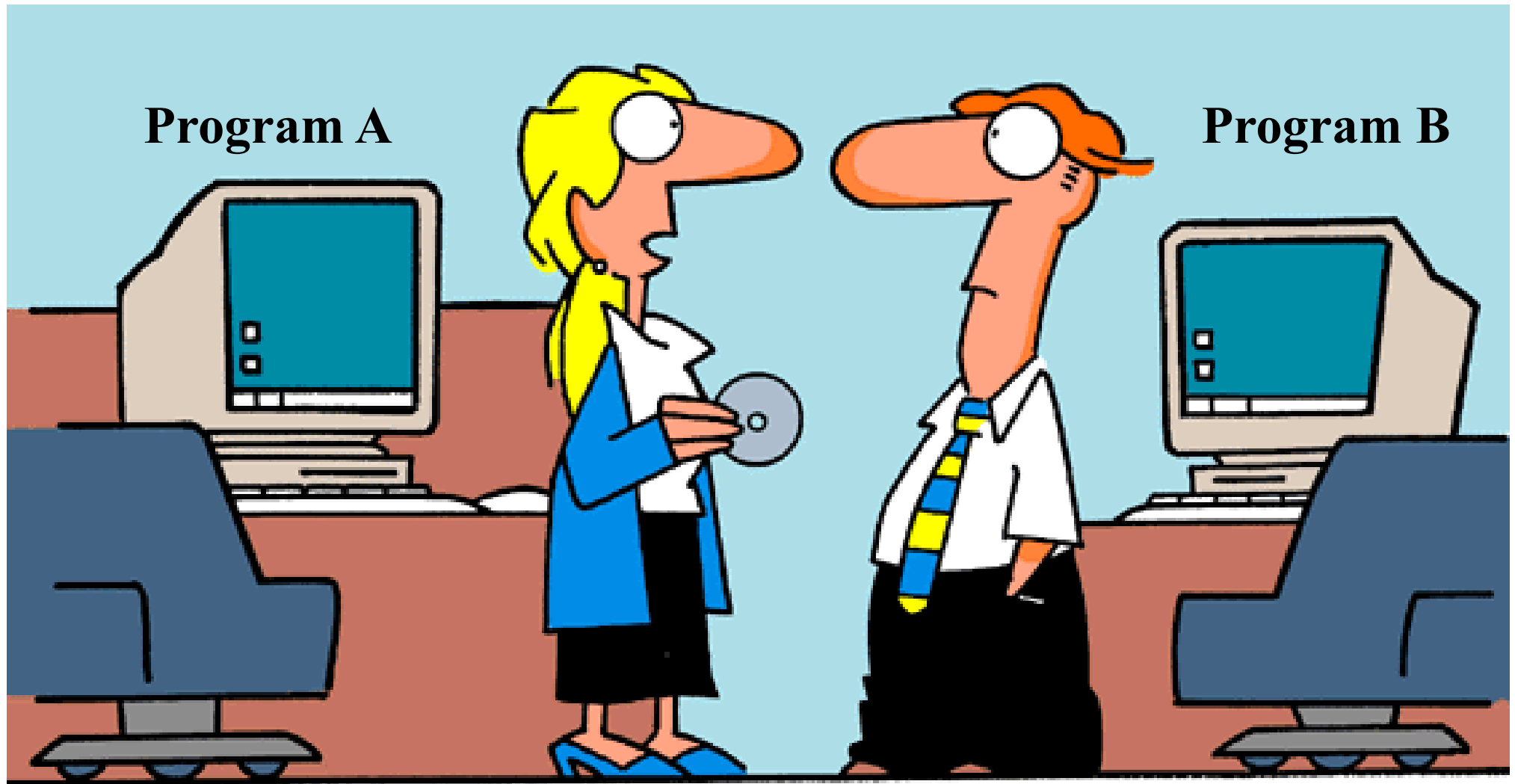

“Several people using several simulation programs on the same building will probably not agree on the results of an energy analysis.”



Simulation Skills

- What constitutes an “accurate” output?
(general guideline only)
 - Annual energy use within 5-10% of actual
 - Seasonal energy use profiles should match
 - Daily energy use profiles match (if needed)
 - End-use energy components is faithfully allocated
- Check with “rules of thumb” or check figures
 - Such as typical load densities, airflow, water flow

Accuracy checklist for building energy simulation

Building Survey:

- Adequate knowledge of building occupancy & use?
- Adequate knowledge of HVAC function & use?
- Measured/accounted for all electrical demand?

Simulation Program:

- Adequate documentation?
- Adequate experience/knowledge of program?

Output Critique:

- Thermal load check?
- Annual energy use checks?
- Annual profile checks?
- Hourly profile checks?
- Retrofit simulation make sense?
- Overall savings level is plausible?



Simulation Skills

- Expected precision (general guideline only)
 - Energy
 - Average monthly error $>$ annual error
 - $\pm 8-10\%$ monthly energy
 - $\pm 3-5\%$ annual energy
 - Annual
 - Average monthly error $>$ Average annual error
 - $\pm 10-12\%$ monthly peak demand
 - $\pm 5-6\%$ annual average peak demand
 - Monitored data can cut the error in half



Simulation Skills

- Consider the building to be simulated
 - What building features are likely to be significant drivers of energy performance
 - Which energy conservation measure(s) are likely to be of particular interest
- Quality control to avoid/reduce errors
 - Check and review by competent persons
 - Well-organised documentation



Simulation Skills

- Attacking the errors
 - Check careless errors in the inputs
 - Examine discrepancies in the output
 - Understand the simulation algorithms (reread the appropriate sections of the users' manual)
 - Understand the building or the design
 - Increased attention to detail in inputs
 - Tweak certain inputs to correct the errors

ORIGINAL MODEL VS. ACTUAL

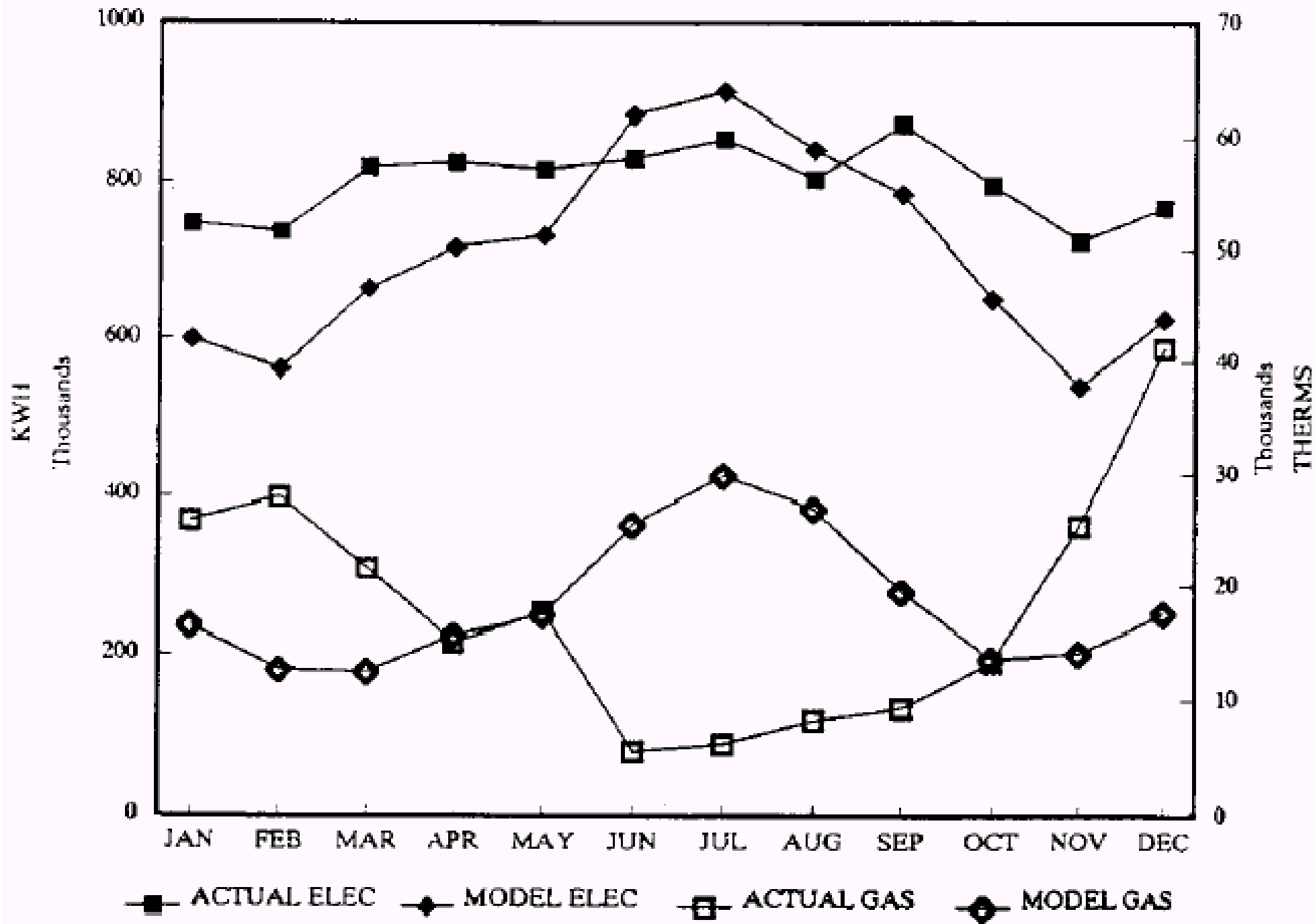

ERA – MODEL VS. ACTUAL

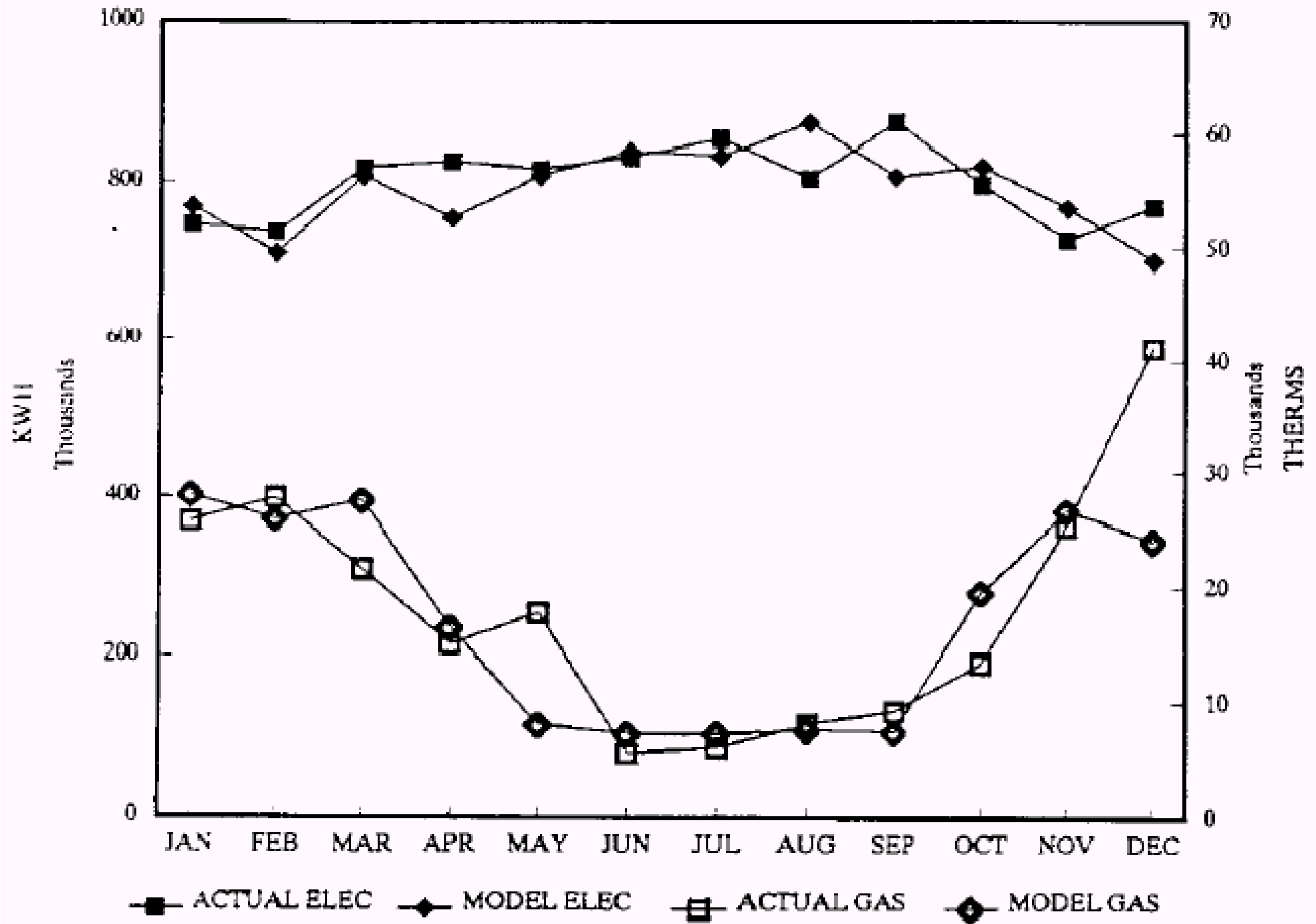

(Source: Waltz, J. P., 2000. *Computerized Building Energy Simulation Handbook*, Fairmont Press, Lilburn, GA.)



Simulation Skills

- Remember simulation tool cannot compensate for bad assumptions or sloppy input
 - Maintain humility and scepticism
 - Good modellers require a lot of system design knowledge and understanding of real operations
- How well it works depends on YOU?





Further Reading

- Understanding the Energy Modeling Process: Simulation Literacy 101, http://www.buildinggreen.com/features/mr/simlit_101.cfm
- Energy Analysis Tools (Whole Building Design Guide), www.wbdg.org/resources/energyanalysis.php
- Hui, S. C. M., 1998. Simulation based design tools for energy efficient buildings in Hong Kong, <http://web.hku.hk/~cmhui/hkpdd/hkpdd-v1.htm>